

Holden Commodore. Holden Calais.

VK SERIES

SERVICE MANUAL SUPPLEMENT

FOREWORD

The information in this Supplement, when used in conjunction with Holden Commodore 'VB' series Service Manual M38145, 'VB' Station Wagon Supplement M38265, VC Service Manual Supplement (Number 1) M38366 and Number 2 M38401, Improved Performance L6 & V8 Engines Service Manual M38338 and VH Series Service Manual Supplement M38731, provides new specifications and new service procedures for *Holden Commodore and Holden Calais VK Series vehicles*.

Transmission, front brake and rear axle assemblies are similar to those used in other GMH vehicles. No major service repair and overhaul procedures are given for these assemblies, and reference should be made to existing Service Manuals.

The Section Index on this page enables the user to quickly locate the numeric identifiers for each group of Sections. Bend the Manual back to expose the black tabs on the pages and locate the tab indicating the identifier for the group of Sections you wish to find. An index is included at the beginning of each Section. In addition, numeric identifiers are also used to signify the individual operations within the Sections. Specifications for vehicle components are provided at the end of each Section where appropriate.

Summaries of Special Service Tools, where required, are also included at the end of Sections.

Service Tools, unless otherwise specified, are available from:

- Kent-Moore Australia Pty. Ltd.
Unit 3, 9 Pioneer Avenue,
Thornleigh, N.S.W. Australia. 2120.
Telephone (02) 848-9777 Telex 22355

General Motors-Holden's does not endorse, prefer, or assume responsibility for the products of this firm nor for any such items which may be available from other makers.

All information, illustrations and specifications contained in this Supplement are based on the latest product information available at the time of publication approval. The right is reserved to make changes at any time without notice.

EFFECTIVE: MARCH, 1984.
SERVICE MANUAL NO. M39101
I.S.B.N. 0 86836 009 0
PRINTED IN AUSTRALIA

SECTION INDEX

0	A - GENERAL INFORMATION B - LUBRICATION
1	A - BODY C - RADIATOR GRILLE D - BUMPER BARS
2	A - VENTILATION & HEATING B - AIR CONDITIONING
3	FRONT SUSPENSION
4	A - REAR SUSPENSION B - REAR AXLE C - PROP SHAFT & UNIVERSAL JOINTS
5	BRAKES
6	A - ENGINE MECHANICAL B - ENGINE COOLING C - ENGINE FUEL D - ENGINE ELECTRICAL E - ENGINE EMISSION CONTROL F - ENGINE TUNE
7	A - CLUTCH B - MANUAL TRANSMISSION C - AUTOMATIC TRANSMISSION
8	A - FUEL TANK B - EXHAUST SYSTEM
9	STEERING
10	WHEELS & TYRES
12	A - BATTERY & CABLES B - LIGHTING SYSTEM C - INSTRUMENTS, GAUGES, WINDSHIELD WIPERS/WASHERS & HORN D - RADIO & TAPE PLAYER E - WIRING HARNESSSES & FUSES F - WIRING DIAGRAMS

GENERAL MOTORS-HOLDEN'S SALES PTY. LIMITED
SERVICE DEPARTMENT

COPYRIGHT - GENERAL MOTORS-HOLDEN'S SALES PTY. LTD.
Reproduction in whole or in part prohibited without written approval

SECTION 0A

GENERAL INFORMATION

INDEX

Ref.	Subject	Page	Ref.	Subject	Page
1.	GENERAL DESCRIPTION	0A-1	6.4	VEHICLE IDENTIFICATION NUMBERING SYSTEM	0A-5
2.	MODEL AVAILABILITY & BASE EQUIPMENT	0A-2	6.5	VEHICLE SERIAL NUMBER	0A-6
3.	POWER TRAIN COMBINATIONS	0A-2	6.6	ENGINE SERIAL NUMBER	0A-6
4.	ENGINE DATA	0A-3	7.	ADDITIONAL GENERAL INFORMATION...	0A-6
5.	EXTERIOR DIMENSIONS	0A-3		Electrical Transients and Radio	
6.	SERIAL NUMBERS	0A-4		Frequency Interference	0A-6
6.1	LOCATION OF IDENTIFICATION PLATES	0A-4		Radio Frequency Interference	0A-7
6.2	SAFETY COMPLIANCE PLATE	0A-4		Electrical Transients	0A-7
6.3	BODY & OPTION IDENTIFICATION PLATE	0A-4			

1. GENERAL DESCRIPTION

The VK Series is a minor facelift of the VH Series incorporating exterior, interior and mechanical changes.

The model line-up differs from the VH Series, with the deletion of the 69 body style (4 door, 4 window sedan) and the introduction of the 19 body style (4 door, 6 window sedan).

MODEL LINE UP		
8VK19	Commodore SL	Sedan 4 door, 6 window
8VK35	Commodore SL	Station Wagon
8VL19	Commodore Berlina	Sedan 4 door, 6 window
8VL35	Commodore Berlina	Station Wagon
8VX19	Calais	Sedan 4 door, 6 window

The 3.3 litre L6 engine, equipped with Electronic Spark Timing (EST), is the base engine for SL and Berlina models, and the 3.3 litre L6 engine equipped with Electronic Fuel Injection (EFI) is the base engine on Calais models.

The three speed Trimatic Automatic Transmission is standard equipment on Calais and Berlina models and is available as an option on Commodore SL models. The Torquemaster four speed manual transmission is standard on Commodore SL models.

The 5.0 litre V8 engine is available on all models as an option. A five speed manual transmission is also available as an option on all 3.3 litre L6 EST engines

The following charts contain model availability, power train combinations, engine data and exterior dimensions for VK Series models.

0A-2 GENERAL INFORMATION

2. MODEL AVAILABILITY & BASE EQUIPMENT

BODY STYLE	MODEL NO.	MODEL NAME	No. OF DOORS	ENGINE	TRANSMISSION		REAR AXLE RATIO : 1	TYRES	WHEELS
					TYPE	SHIFT LOC.			
Sedan	8VK19	Commodore SL	4	3.3 EST	4 Speed Manual	Floor	3.08	BR78S14	5.50 JJX14 Steel
S/Wagon	8VK35	Commodore SL	5	3.3 EST	4 Speed Manual	Floor	3.08	CR78S14	6.0 JJX14 Steel
Sedan	8VL19	Commodore Berlina	4	3.3 EST	3 Speed Auto	Floor	3.08	CR78S14	6.0 JJX14 Steel
S/Wagon	8VL35	Commodore Berlina	5	3.3 EST	3 Speed Auto	Floor	3.08	CR78S14	6.0 JJX14 Steel
Sedan	8VX19	Calais	4	3.3 EFI	3 Speed Auto	Floor	3.08	P205/ 60HR15	6.0 JJX15 Alloy

3. POWER TRAIN COMBINATIONS

ENGINE	TRANSMISSION TYPE	MODEL AVAILABILITY	FIRST GEAR RATIO : 1	REAR AXLE RATIO : 1	
				BASE	PERFORMANCE
3.3 Litre Six Cylinder EST	4 Speed Manual	SL Sedan SL Station Wagon Berlina Sedan Berlina Station Wagon	3.50	3.08	
	5 Speed Manual	SL Sedan SL Station Wagon Berlina Sedan Berlina Station Wagon	3.24	3.36	
	3 Speed Automatic	SL Sedan SL Station Wagon Berlina Sedan Berlina Station Wagon	2.31	3.08	
3.3 Litre Six Cylinder EFI	3 Speed Automatic	SL Sedan Berlina Sedan Calais	2.31	3.08	
5.0 Litre Eight Cylinder	3 Speed Automatic	All Models	2.31	2.60	3.08

4. ENGINE DATA

ENGINE DESIGNATION	3.3 LITRE EST	3.3 LITRE EFI	5.0 LITRE
PISTON DISPLACEMENT NOM. – cc	3298	3298	5044
COMPRESSION RATIO : 1	8.8	8.8	9.2
NUMBER OF CYLINDERS BORE x STROKE – mm	6 92.075 x 82.550	6 92.075 x 82.550	8 101.60 x 77.775
TAXABLE H.P. RAC or SAE	31.5	31.5	51.2
POWER K.W. DIN @ R.P.M.	86 kw @ 4200	106 kw @ 4400	117 kw @ 4000
TORQUE Nm DIN @ R.P.M.	232 Nm @ 2400	266 Nm @ 3200	336 Nm @ 2400

5. EXTERIOR DIMENSIONS

BODY DIMENSIONS	SEDAN MODELS			STATION WAGON MODELS	
	8VK19	8VL19	8VX19	8VK35	8VL35
OVERALL LENGTH	4713.5	4713.5	4713.5	4716.5	4716.5
OVERALL WIDTH	1722	1722	1722	1722	1722
OVERALL HEIGHT	1378	1374	1360	1401	1465
WHEELBASE	2668	2668	2668	2668	2668
OVERHANG – FRONT	922.5	922.5	922.5	922.5	922.5
OVERHANG – REAR	1123	1123	1123	1126	1126
TREAD – FRONT	1451.3	1451.3	1451.3	1451.3	1451.3
TREAD – REAR	1416.5	1416.5	1416.5	1440	1440

Dimensions in mm

0A-4 GENERAL INFORMATION

6. SERIAL NUMBERS

The complete vehicle and various components of the vehicle are identified by number plates or numbers stamped into the part. It is essential that when compiling warranty claims or product and field reports that the vehicle identification number 'VIN' is quoted in conjunction with the identification number of the component affected.

6.1 LOCATION OF IDENTIFICATION PLATES

Plates are attached to the left side wheelhouse reinforcement and the front panel upper (refer Fig. 0A-1).

SAFETY COMPLIANCE PLATE - Refer Fig. 0A-2.

BODY AND OPTION IDENTIFICATION PLATE - Refer Fig. 0A-3.

VEHICLE IDENTIFICATION PLATE - Refer Fig. 0A-4.

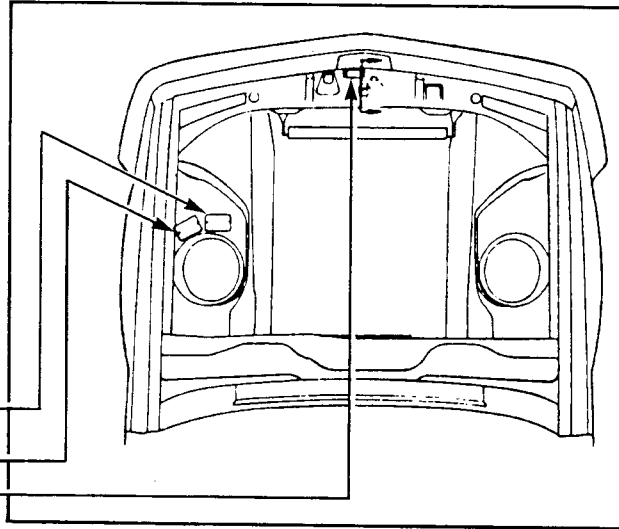

Figure 0A-1

6.2 SAFETY COMPLIANCE PLATE

(Not applicable to Export).

Plate stamped with the following information: Refer Fig. 0A-2.

AUSTRALIAN DESIGN RULE NOS. (A.D.R.)

VEHICLE MAKE - HOLDEN.

VEHICLE MODEL NAME AND STYLE.

MONTH AND YEAR OF MANUFACTURE.

VEHICLE SERIAL NUMBER.

SEATING CAPACITY OF VEHICLE.

GROSS VEHICLE MASS IN KILOGRAMS.

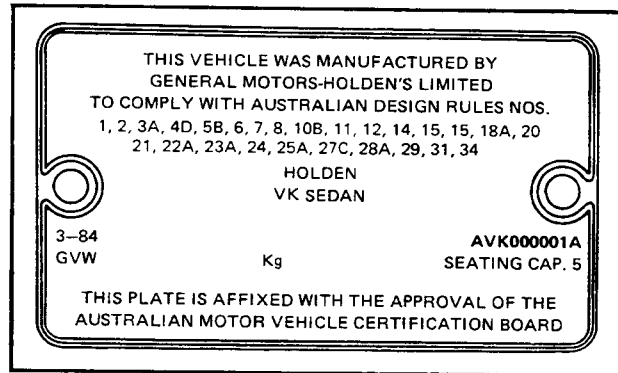

Figure 0A-2

6.3 BODY & OPTION IDENTIFICATION PLATE

Plate stamped with the following information - Refer Fig. 0A-3.

MODEL:

Combination of letters and numbers identifying the Body, Model and Style.

BODY NO.:

Reference number followed by Assembly Plant Suffix.

A - Adelaide

M - Melbourne

NZ - New Zealand

TRIM:

Exterior Paint Colour and Trim combination.

PAINT:

Exterior Paint Material and Colour identification.

BUILT:

The date of manufacture by calendar month and year in which the body shell and power train are conjoined and the vehicle is driven or moved from the production line.

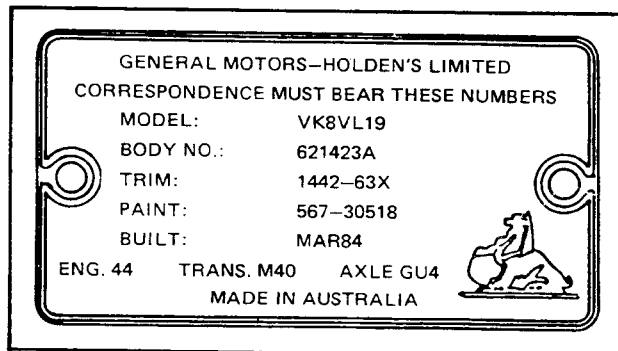

Figure 0A-3

6.4 VEHICLE IDENTIFICATION NUMBERING SYSTEM

The Vehicle Identification Numbering System (V.I.N.) is based on the uniform Car Model Designation System. This is to identify the vehicle in one coded series of characters.

The significance of these characters or blocks of characters is explained below, using as an example identification number:-

8 L 19 L D L6 00025 K

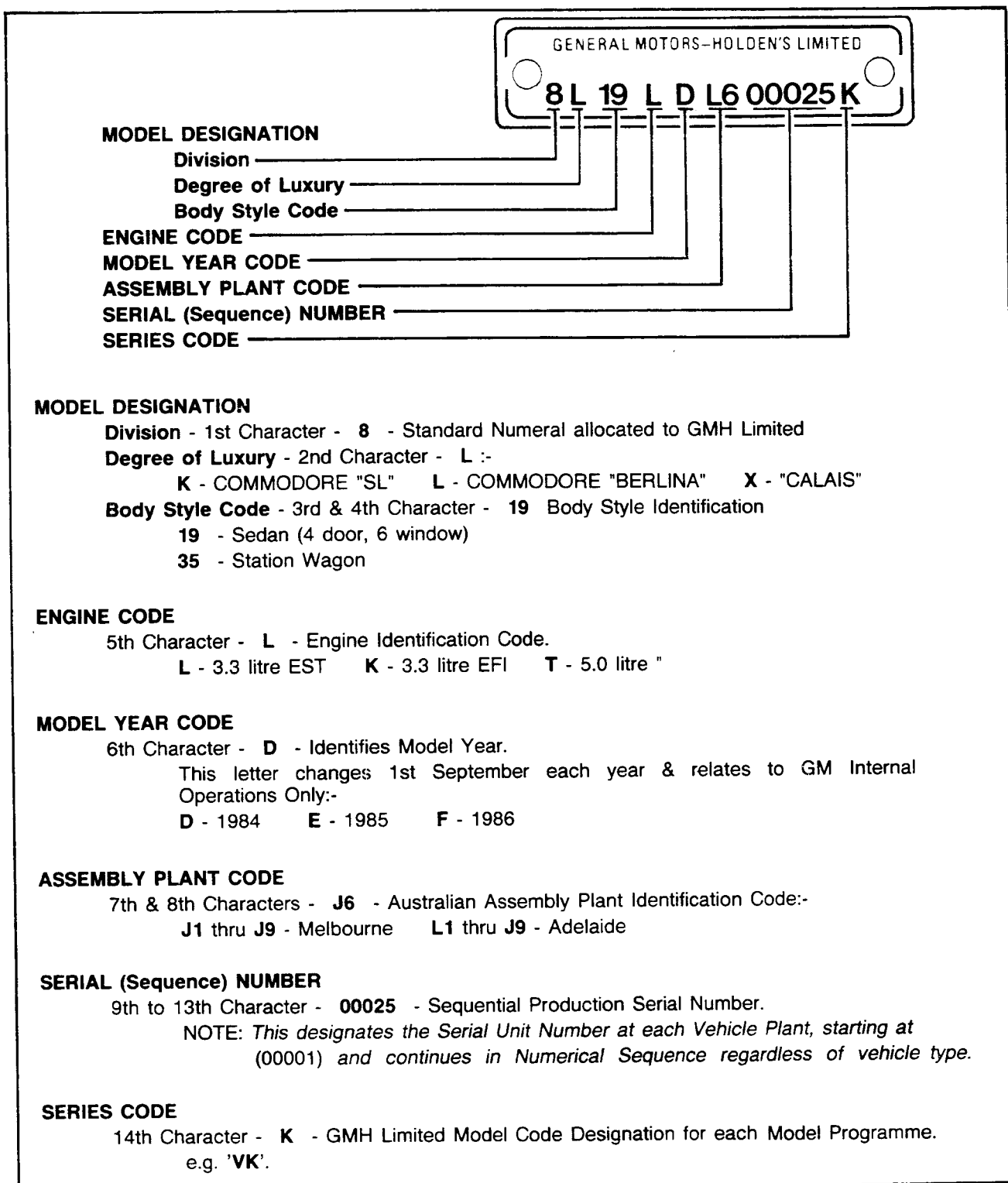

Figure 0A-4

0A-6 GENERAL INFORMATION

6.5 VEHICLE SERIAL NUMBER

The vehicle serial number is stamped on the top of the left hand side strut tower - Refer Fig. 0A-5.

1. DESIGN RULE COMPLIANCE LETTER.
2. VEHICLE SERIES 'VK'.
3. ASSEMBLY PLANT SERIAL NUMBER.
4. ASSEMBLY PLANT IDENTIFICATION 'A' ADELAIDE, 'M' MELBOURNE.
5. REQUIREMENT IN EVENT OF SERIAL NO. DUPLICATION.
6. REQUIREMENT IN EVENT OF SECOND OR FURTHER SERIAL NO. DUPLICATION.

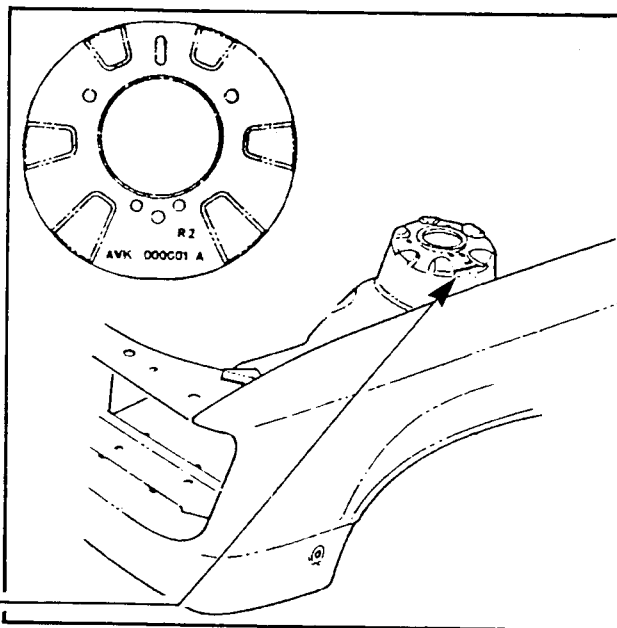
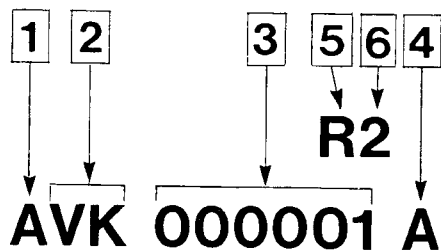

Figure 0A-5

6.6 ENGINE SERIAL NUMBER

The engine number for 3.3 litre engine is stamped on a pad above the right hand engine mounting boss, and at top front left side of cylinder and case for 5.0 litre engines.

ENGINE NUMBER PREFIX	ENGINE TYPE
VL	3.3 litre EST
VK	3.3 litre EFI
VT	5.0 litre Automatic

7. ADDITIONAL GENERAL INFORMATION

ELECTRICAL TRANSIENTS AND RADIO FREQUENCY INTERFERENCE

Electronic circuits are used in VK Series models to perform a number of functions associated with electronic instruments, electronic fuel injection and electronic spark timing. These circuits can be damaged or cause malfunction by electrical transients or excessive radio frequency (RF) radiation.

RADIO FREQUENCY INTERFERENCE

One of the chief sources of RF interference is the ignition system; other sources include CB radio and radio telephones. The following are normally used to suppress RF interference.

Resistors e.g. high tension cables and connectors.

Capacitors and choke coils.

Metal braid for screening leads or suppression covers made from conductive material for screening equipment.

To prevent damage to equipment:

Do not replace interference - suppressed high tension ignition cables or connectors with un-suppressed types.

Do not remove or reposition interference suppression filters or capacitors.

ELECTRICAL TRANSIENTS

Electrical transients are high voltage spikes produced by the sudden switching or interruption of electric currents. Older style timing lights and battery chargers can produce serious transients, hence it is important to use only good quality equipment suitable for use with electronic systems.

It is also good practice to ensure that the battery is disconnected before using a battery charger.

Indiscriminate fitting of solenoids, indicators or relays can also cause transients.

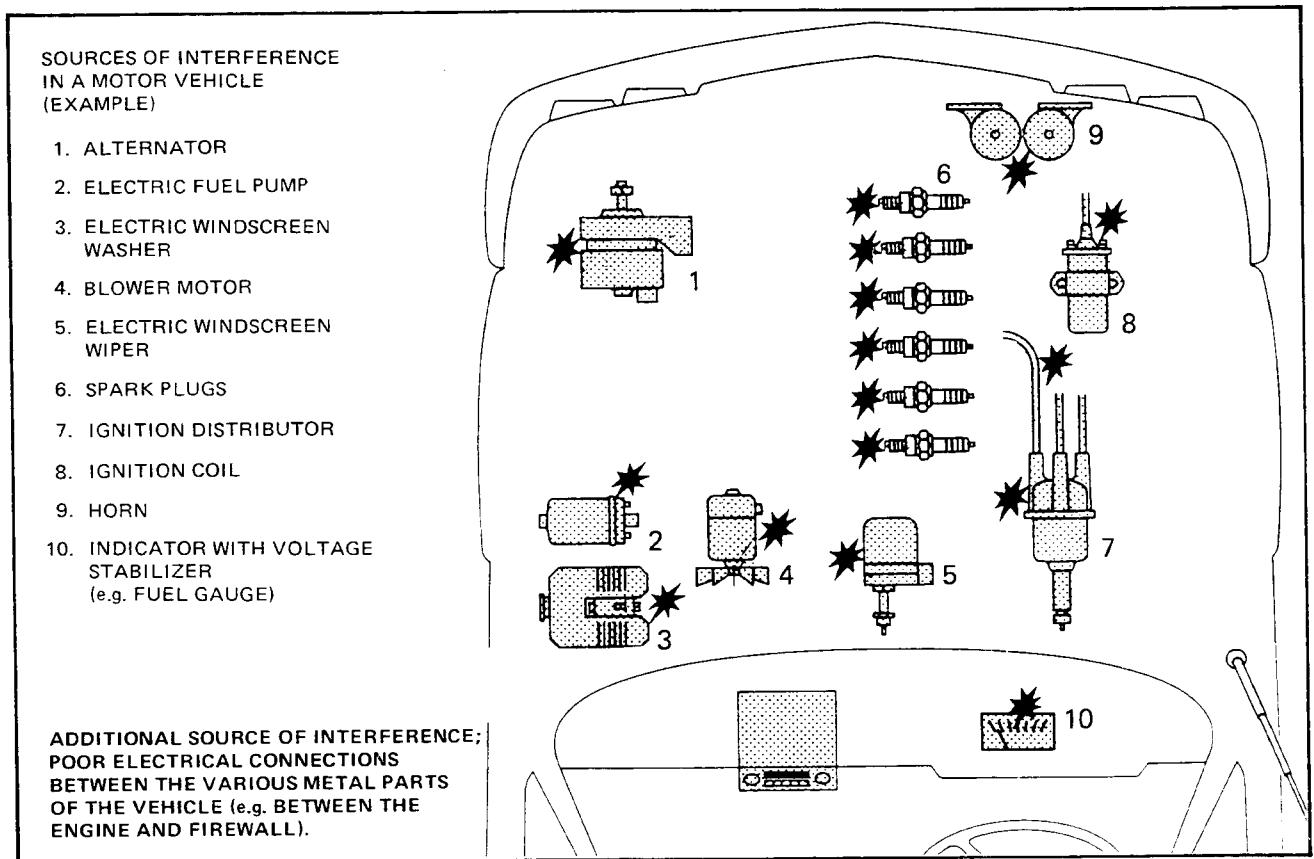

Figure 0A-6

SECTION 0B

LUBRICATION

INDEX

Ref.	Subject	Page	Ref.	Subject	Page
1.	GENERAL INFORMATION	0B-1	1.3	AIR CLEANER.....	0B-2
1.1	RECOMMENDED LUBRICANTS	0B-2	1.4	FUEL FILTER	0B-3
1.2	BRAKE FLUID REPLACEMENT.....	0B-2	1.5	COOLING SYSTEM	0B-3

1. GENERAL INFORMATION

This section provides details of the lubricants specific to VK series vehicles.
Instructions on the time or distance intervals at which

services should be carried out are contained in the Service and Maintenance Section of the VK Series Owner Handbook.

CAPACITIES		
	ENGINE SIZE	CAPACITY
Engine – Service Refill	3.3 Litre	3.7 Litres
	5.0 Litre	4.33 Litres
Add for Oil Filter	ALL	.3 Litres
Manual Transmission (Production Option MC6)	3.3 Litre EST	1.6 Litres
Manual Transmission (Production Option M76)	3.3 Litre EST	2.75 Litres
Automatic Transmission (Dry) (Inc. Converter) Service Refill	3.3 Litre	6.1 Litres
	5.0 Litre	8.7 Litres
Cooling System	3.3 Litre	2.3 Litres
	5.0 Litre	2.3 Litres
Brake Hydraulic System	3.3 Litre	8.5 Litres approx
	5.0 Litre	12.0 Litres approx
	ALL	.62 Litres

0B-2 LUBRICATION

1.1 RECOMMENDED LUBRICANTS

COMPONENTS	GMH SPECIFICATION	LUBRICANTS
Engine 3.3 Litre EST 3.3 Litre EFI 5.0 Litre	SE Oils SE Oils SF Oils for severe service. Refer Owners Handbook. SE Oils	For grades and application, refer Fig. 0B-1 For grades and application, refer Fig. 0B-1 For grades and application, refer Fig. 0B-1
Manual Transmission Production Option MC6 Production Option M76	HN1046 HN1855	SAE 80W90 Castrol Gear Oil 80W
Automatic Transmission	GM9985286	DEXRON II Automatic Transmission Fluid
Rear Axle Rear Axle L.S.D.	HN1181 if unavailable HN1561	EP SAE 90
Power Steering	GM9985286	DEXRON II Automatic Transmission Fluid
Brake System	HN1796	Polyglycol Brake Fluid to GM Specification HN1796

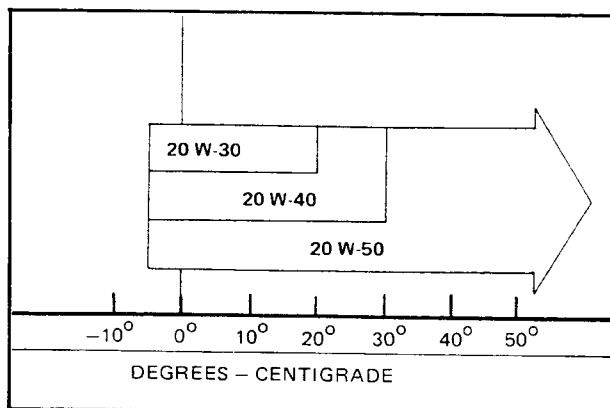

Figure 0B-1

1.2 BRAKE FLUID REPLACEMENT

The polyglycol brake fluid used in VK Series models is hygroscopic and absorbs moisture from the air through the brake hoses etc. The boiling resistance of the fluid decreases as the moisture content increases and so the possibility of a vapour lock under heavy braking conditions increases with the age of the fluid. Therefore, for maximum brake effectiveness, a two yearly change of brake fluid is mandatory. Service instructions for changing brake fluid are covered in Section 5, Service Operation 2.1 in this Supplement.

1.3 AIR CLEANER

The air cleaner element may be partially cleaned of dust by lightly tapping the element. It should not be washed or oiled. The time or distance intervals at which the element requires servicing depends on the vehicle operating conditions. Under dusty conditions, the element should be checked for restriction more often than for normal city operation.

The air cleaner element should be replaced at the time or distance interval specified in the VK Series Owner Handbook.

Service Instructions for the removal and installation of the air cleaner element (Fig. 0B-2), on vehicles with electronic fuel injection are covered in Section 6C, Service Operation 3.6 in this Supplement.

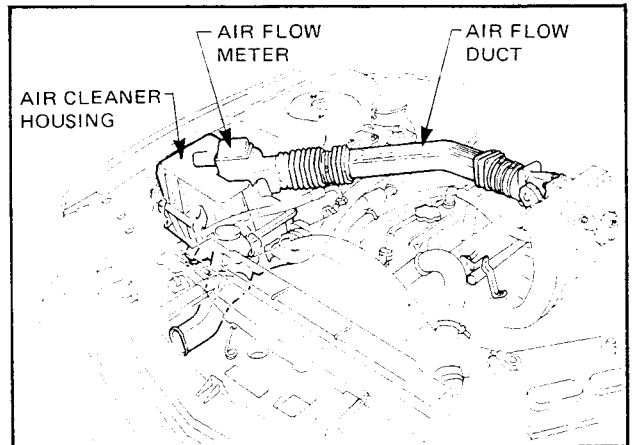

Figure 0B-2

1.4 FUEL FILTER

On 3.3 litre engines with electronic spark timing, a fuel filter is located in the suction side of the fuel line and attached to the right hand fender panel. Refer Fig. 0B-3.

On electronic fuel injected vehicles, the fuel filter (Fig. 0B-4) is located on the pressure side of the fuel pump and attached to the floor pan of the vehicle, in front of the differential.

Fuel filters should be replaced at the time or distance intervals specified in the VK Series Owner Handbook.

Service Instructions for the removal and installation of the fuel filter on electronic fuel injected vehicles are covered in Section 6C, Service Operation 3.15 in this Supplement.

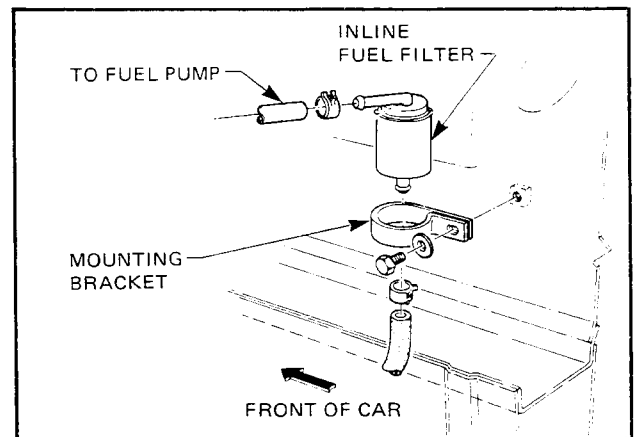

Figure 0B-3

1.5 COOLING SYSTEM

The cooling system is filled initially with a coolant mixture comprising 1.5% to 3.0% (by volume) of corrosion inhibitor to GMH specification HN1109.

It is recommended that the coolant be drained, the system flushed and refilled with clean water and inhibitor mixture at the time and distance intervals set out in the VK Series Owner Handbook.

Refer to Service Operation 2.2, Section 6B 'Cooling System' of this Supplement for details.

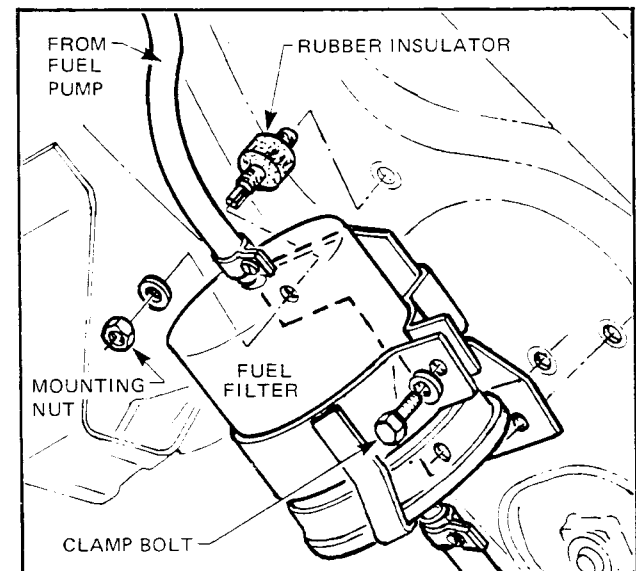

Figure 0B-4

SECTION 1A

BODY

CONTENTS OF THIS SECTION

Ref.	Subject	Page	Ref.	Subject	Page
1.	GENERAL INFORMATION	1A-1	6.	SEATS & SEAT BELT ASSEMBLIES	1A-31
2.	UNDERBODY	1A-3	7.	EXTERIOR ORNAMENTATION	1A-39
3.	FRONT END.....	1A-9	8.	ROOF RACK	1A-51
4.	REAR QUARTER	1A-19	9.	BODY ELECTRICAL.....	1A-53
5.	STATIONARY GLASS	1A-21	10.	SPECIAL TOOLS	1A-67

1. GENERAL INFORMATION

INDEX

Ref.	Subject	Page	Ref.	Subject	Page
1.1	GENERAL DESCRIPTION.....	1A-1	1.2	SERVICE NOTES	1A-1

1.1 GENERAL DESCRIPTION

This Section contains descriptions and procedures for interior and exterior body service operations on VK Series Commodore and Calais models. When used in conjunction with previously released Commodore Service Publications, it will provide information necessary for efficient servicing of VK body styles and their related assemblies.

The VK Series includes two different body styles: the 19 Style, which is a six window sedan and the 35 style Station Wagon.

The stationary fifth and sixth windows on the new 19 Styles are retained in their upper rear quarter apertures with urethane adhesive, which creates a bond between the glass and the metal flange to which it is applied. On 35 Styles, the tailgate window is retained with urethane adhesive; the same material which is used in production to retain the JB Camira Windshields and back windows.

Also featured on VK Series are revised transmission consoles, new instrument panel facia and instruments, seat and door trim designs and 'see through' head restraints on front seats.

On the Calais model, see through head restraints are fitted to the rear seats. Electrically controlled exterior rear vision mirrors are also standard on this model. An adjustable lumbar support built into the drivers seat back is included on Berlina and Calais models.

VK external features include new exterior ornamentation, decals, tailgate handle on 35 body style, radiator grille and colour co-ordinated front and rear bumper bar assemblies.

Front turn signal lamps and rear lamp assemblies are also new.

1.2 SERVICE NOTES

CAUTION: As a sound deadening medium, a small volume of polyurethane foam is installed into the upper section of the rear body pillars of VK Commodore sedans, as illustrated in shaded areas in Fig. 1A-1. During normal service, there is no risk associated with its use. However, when polyurethane is subjected to high temperatures such as during welding or naked flame cutting, this material can release black pungent fumes. During repair of these parts of the body structure

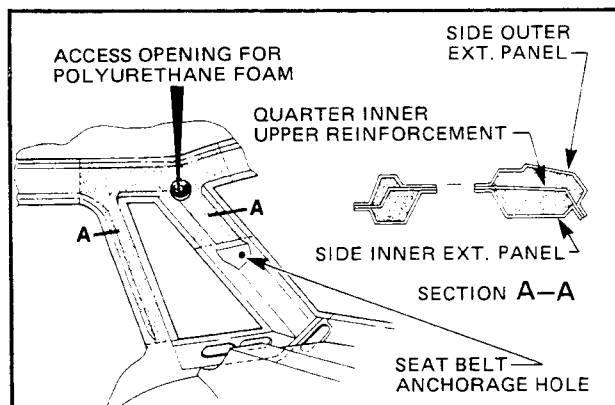

Figure 1A-1

involving high heat application, appropriate precautions against fume inhalation such as the wearing of respirators, forced ventilation, etc., are mandatory. Whenever possible, such repairs should be carried out without the use of high temperature producing equipment.

IMPORTANT: Whenever items such as body side mouldings, Dealer name plates, mud/splash guards, etc., which require piercing of sheet metal panels, are added to a vehicle after it has been manufactured, a possibility exists for sheet metal corrosion to occur in areas where the metal has been pierced, as well as other areas affected by water entry at the point of piercing. Abrasion of the painted or treated surfaces by the 'added-on' material may contribute to corrosion and unsightly appearances.

The reliability and performance of 'add-on' equipment installations must become the responsibility of the maker and the installer (Dealer or vehicle owner). For this reason, you should evaluate the procedures used in your Dealership (and outside sublet shops) to assure that proper steps are being taken to provide appropriate sheet metal corrosion protection to offset the effects of 'add-on' equipment.

CAUTION: To avoid damage when servicing instrument panels, frames, instrument clusters, etc., it is essential to handle these components with the utmost care.

UNDERBODY DIMENSIONS & HOIST LOCATIONS

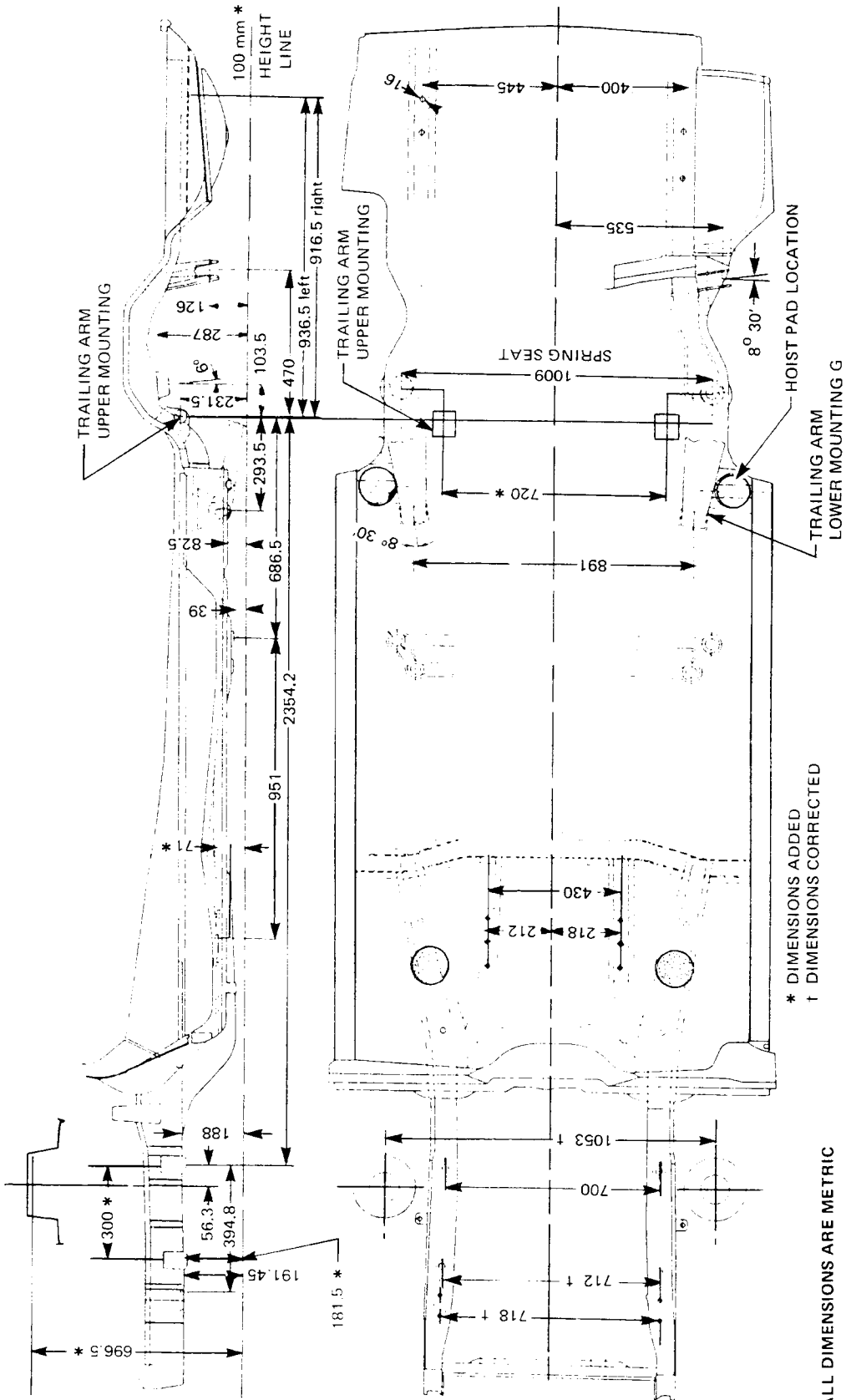

ALL DIMENSIONS ARE METRIC
TOLERANCE ON ALL
DIMENSIONS ± 1.0 mm

* DIMENSIONS ADDED
† DIMENSIONS CORRECTED

THE DIMENSIONS INDICATED THUS * AND † APPLY ALSO
TO VB & VC SERIES AND CAN BE USED TO UPDATE
PREVIOUSLY PUBLISHED DATA.

Figure 1A-1A

2. UNDERBODY

INDEX

Ref.	Subject	Page	Ref.	Subject	Page
2.1	UNDERBODY DIMENSIONS & HOIST LOCATIONS.....	1A-2	2.4	SHROUD LOWER TRIM - RIGHT & LEFT HAND	1A-6
2.2	TRANSMISSION CONSOLE - MANUAL.....	1A-3		Remove.....	1A-6
	Model - 'SL'	1A-3		Reinstall	1A-6
	Remove.....	1A-3	2.5	ROCKER PANEL COVER - RIGHT & LEFT HAND	1A-6
	Reinstall	1A-3		Remove.....	1A-6
	Models - Calais & Berlina fitted with Power Operated Side Windows.....	1A-3		Reinstall	1A-6
	Remove.....	1A-3	2.6	FLOOR COVERING	1A-7
	Reinstall	1A-3		Remove.....	1A-7
2.3	TRANSMISSION CONSOLE - AUTOMATIC	1A-5		Reinstall	1A-7
	Remove.....	1A-5			
	Reinstall	1A-5			

2.1 UNDERBODY DIMENSIONS AND HOIST LOCATIONS

Refer Fig. 1A-1A.

2.2 TRANSMISSION CONSOLE - MANUAL

MODEL - 'SL'

Remove

1. Disconnect battery ground cable.
2. Unscrew knob from gearshift control lever, then screw cover buttons and screws securing front and rear of console to transmission tunnel (refer Fig. 1A-2).
3. Partially raise console then disconnect electrical connectors prior to removal of transmission console.

Reinstall

Reverse removal operations, ensuring that non hardening sealer is applied to the threads of the console attaching screws prior to their installation (refer Fig. 1A-2).

MODELS - CALAIS & BERLINA FITTED WITH POWER OPERATED SIDE WINDOWS

Remove

1. Disconnect battery ground cable.
2. Unscrew knob from gearshift control lever then remove cover from handbrake lever.
3. With console compartment lid raised, remove rear end of carpet in base of console which covers screws securing rear end of console to transmission tunnel bracket (refer Fig. 1A-3) then remove screws.
4. Partially raise rear end of console, disconnect electrical connectors, then easing console rearwards to disengage front end of console from attaching bracket (refer Section B-B, Fig. 1A-3) remove console assembly.

Reinstall

Reverse removal operations.

1A-4 BODY

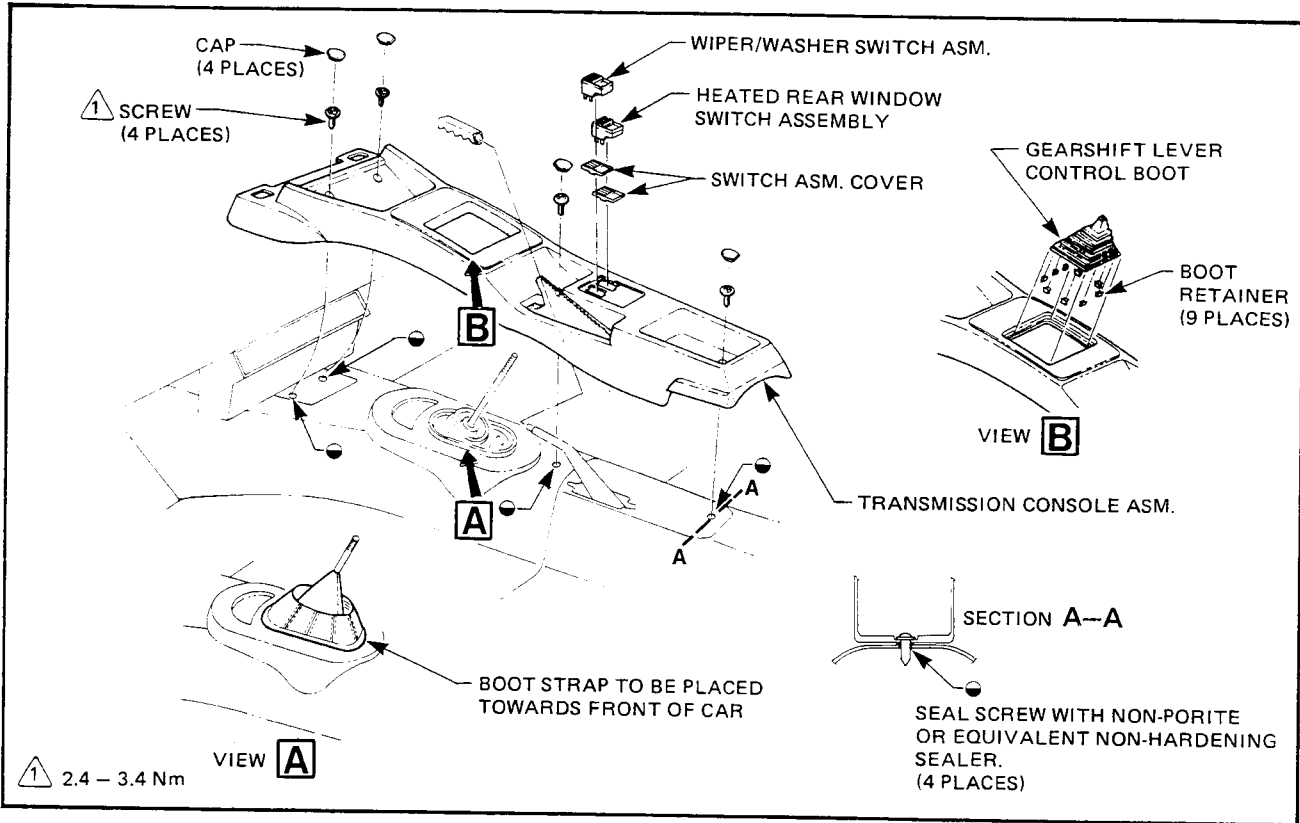

Figure 1A-2

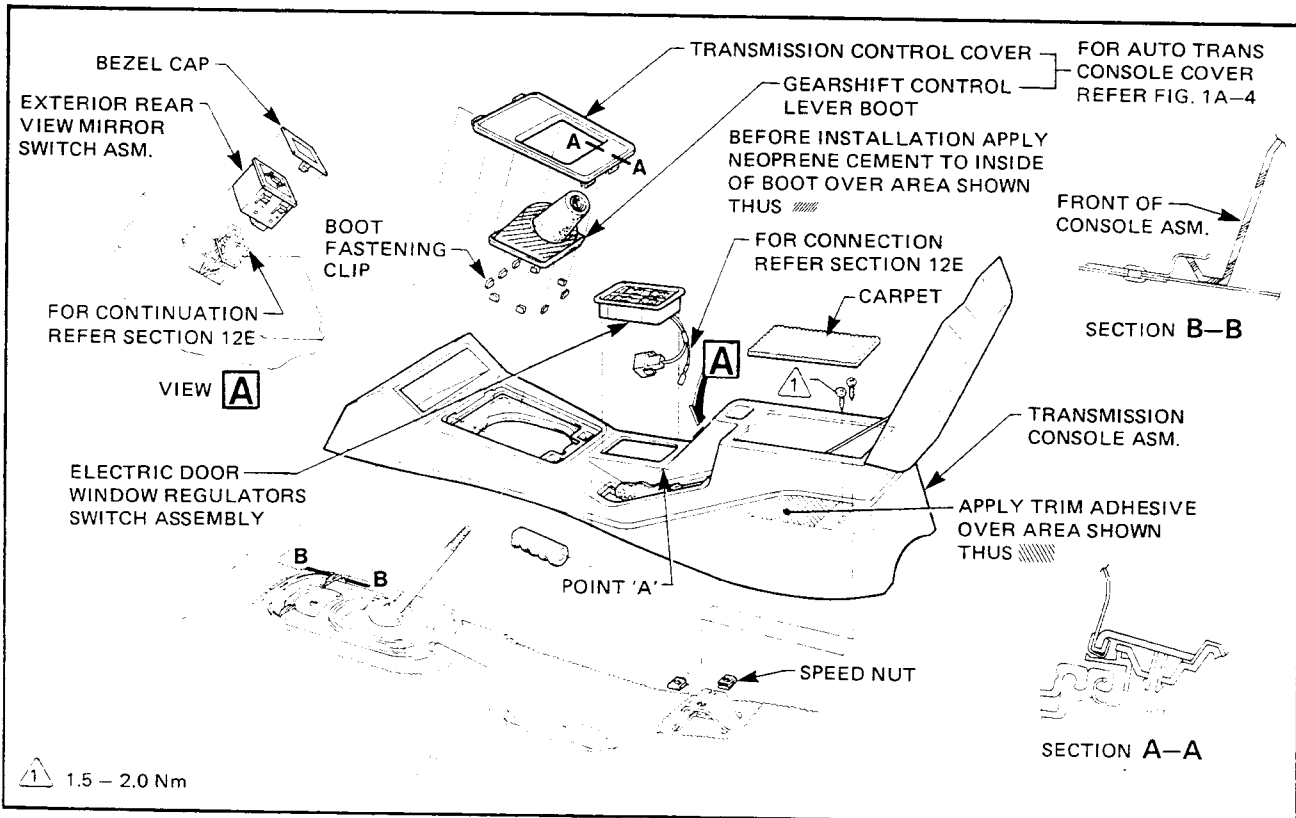

Figure 1A-3

2.3 TRANSMISSION CONSOLE - AUTOMATIC

Remove

1. Disconnect battery ground cable.
2. Using a wide bladed screwdriver, carefully prise cap from console (refer Section C-C, Fig. 1A-4) turn cap through 90C, then remove cap of 'T' bar gear control lever.
3. Remove gear lever location indicator scale from console (refer Sections A-A and B-B, Fig. 1A-4).
4. On 'SL' models, remove screw cover buttons and screws securing front and rear end of console to transmission tunnel (refer Fig. 1A-2).
5. On Berlina and Calais models, raise console compartment lid and remove rear end of carpet in base of console which covers screws securing rear end of console to transmission tunnel bracket (refer Section B-B, Fig. 1A-3) then remove screws.
6. Partially raise rear end of console, disconnect electrical connectors then, easing console rearwards to disengage front end of console from attaching bracket (refer Section B-B, Fig. 1A-3), then remove screws and console assembly.

Reinstall

Reverse removal operations ensuring that the note referring to automatic console scale installation in Fig.1A-4, is observed.

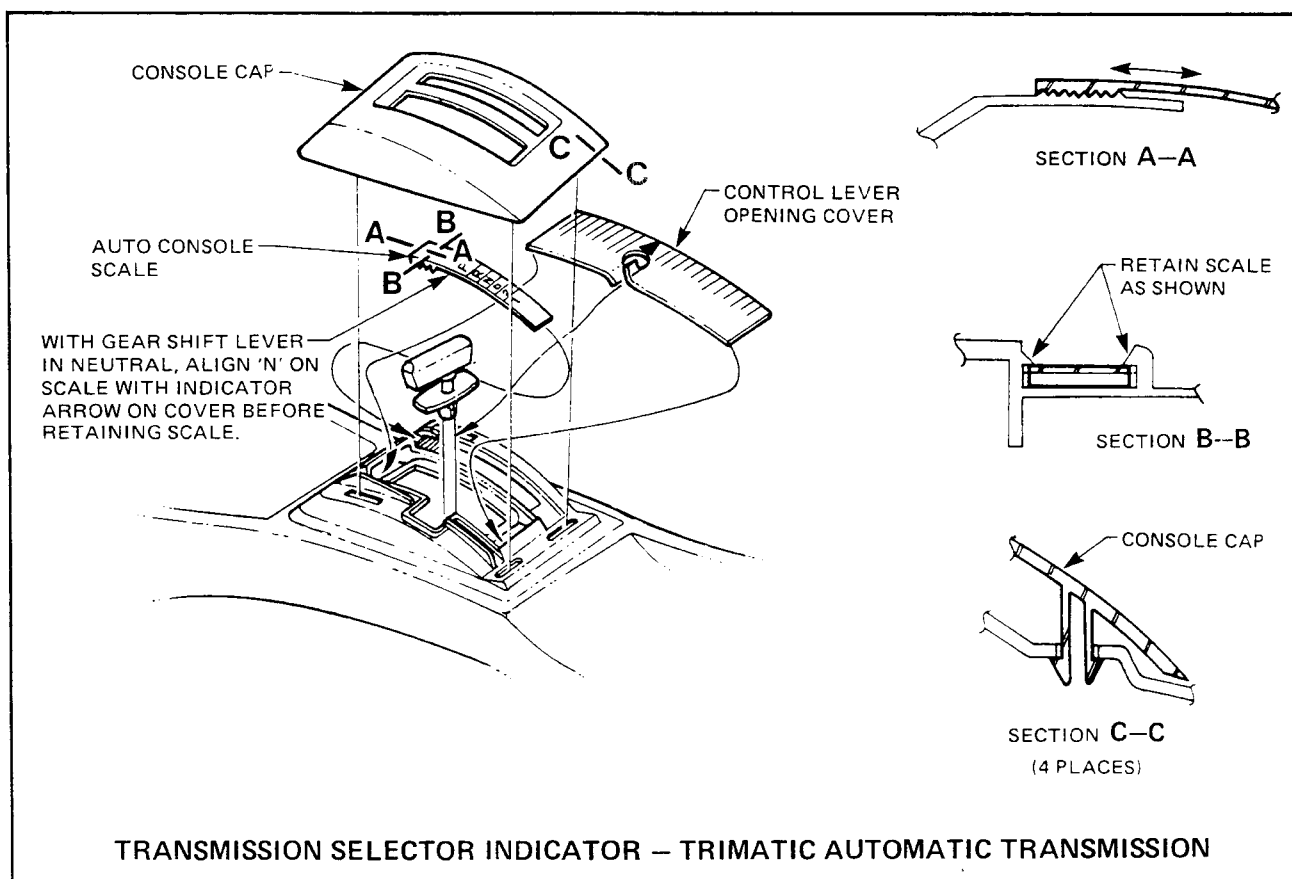

Figure 1A-4

1A-6 BODY

2.4 SHROUD LOWER TRIM - RIGHT & LEFT HAND

REMOVE

1. Prise front end of front rocker panel cover from rocker panel (refer Section A-A, Fig. 1A-5) then ease lower front end of finishing lace and weatherstrip assembly from door opening pinchweld flange (refer Section A-A, Fig. 1A-6).
2. Using a fabricated trim clip removal tool (refer Special Tool Section;) located between shroud lower trim and shroud panel and directly under fastener head (refer Sections B-B and F-F, Fig. 1A-6) carefully prise fasteners from shroud panel, removing trim.

REINSTALL

Reverse removal operations.

2.5 ROCKER PANEL COVER - RIGHT & LEFT HAND

REMOVE

1. Using a wide bladed prising tool positioned between outer edge of cover and rocker panel, carefully prise cover from door opening lower pinchweld flange (refer Fig. 1A-5).

REINSTALL

Locate front cover over door opening lower pinchweld flange, ensuring that ends of cover overlap ends of door opening finishing lace, then using the hand or a rubber mallet, tap top of cover until it completely engages retaining flange.

NOTE: On rear covers, locate front end of rear cover so that it butts against the rear end of the front seat belt retractor cover prior to tapping cover into position.

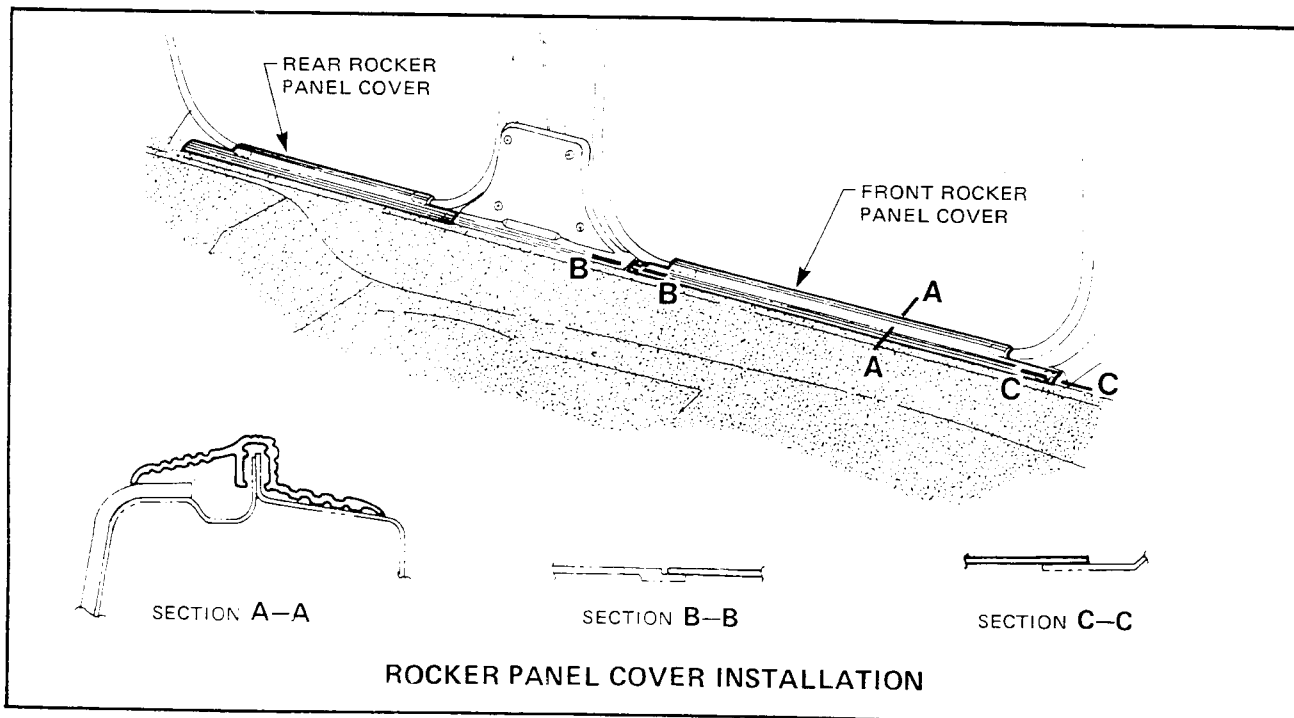

Figure 1A-5

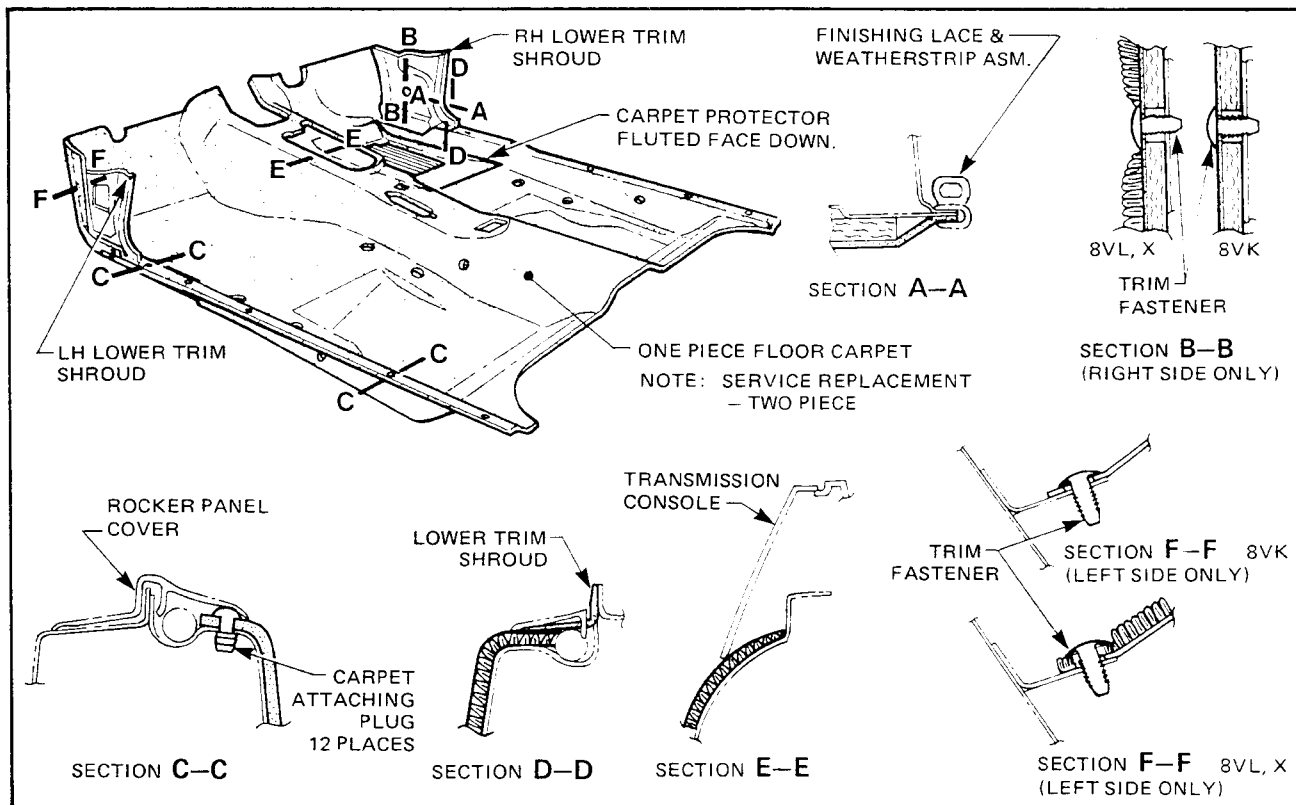

Figure 1A-6

2.6 FLOOR COVERING

REMOVE

1. Disconnect battery ground cable.
2. Remove front end rear rocker panel covers and shroud lower trims (refer 2.5 and 2.4 in this Section).
3. Remove transmission console (refer 2.2 or 2.3 in this Section).
4. Remove panel cover assembly from heater case (refer Fig. 1A-7).
5. Remove front seat and rear seat cushion assemblies.
6. Remove front seat belt retractor covers and seat belt inner and outer, lower attaching bolts (refer 6.3 in this Section).
7. Using a fabricated trim clip removal tool (refer Special Tool Section) located between edge of carpet and rocker panel and directly under head of carpet attaching plug, prise plugs from rocker panels (refer Section C-C, Fig. 1A-6) then remove floor covering.

REINSTALL

Reverse removal operations.

NOTE: Separate front and rear floor coverings are available from GM P & A as Service Replacements.

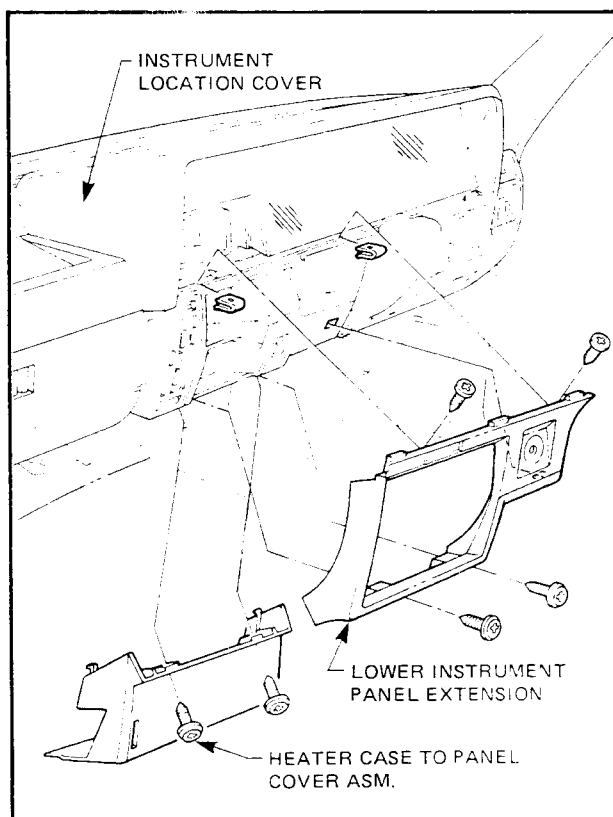

Figure 1A-7

3. FRONT END

INDEX

Ref.	Subject	Page
3.1	SERVICE NOTE	1A-9
3.2	INSTRUMENT PANEL LOWER TRIM - RIGHT & LEFT HAND	1A-9
	Remove.....	1A-9
	Reinstall	1A-9
3.3	INSTRUMENT PANEL PAD	1A-10
	Remove.....	1A-10
	Reinstall	1A-10

Ref.	Subject	Page
3.4	INSTRUMENT PANEL LOWER - RIGHT HAND	1A-16
	Remove.....	1A-16
	Reinstall	1A-16
3.5	INSTRUMENT PANEL LOWER - LEFT HAND INCLUDING RADIO AND RADIO/CASSETTE PLAYER RECEIVER...	1A-16
	Remove.....	1A-16
	Reinstall	1A-17

3.1 SERVICE NOTE

CAUTION: To avoid damage when servicing instrument panels, frames, instrument clusters, etc., it is essential to handle these components with the utmost care.

3.2 INSTRUMENT PANEL LOWER TRIM - RIGHT & LEFT HAND

REMOVE

1. From under instrument panel and using a fabricated trim clip removal tool (refer Special Tool Section) located directly under head of trim clip, carefully prise clips from attaching holes in instrument panel lower (refer Section A-A, Fig. 1A-8) removing trim.

NOTE: Removal of right hand lower trim necessitates disengagement of adjustable strap which partially secures trim to steering column (refer Section D-D, Fig. 1A-8).

REINSTALL

Reverse removal operations ensuring that leading edge of left hand trim is correctly located beneath the dash panel bracket and into wiring harness grommet (refer Section C-C, Fig. 1A-8) and that the leading edge of the right hand trim is located in the accelerator pedal support cap, as illustrated in Section B-B, Fig. 1A-8.

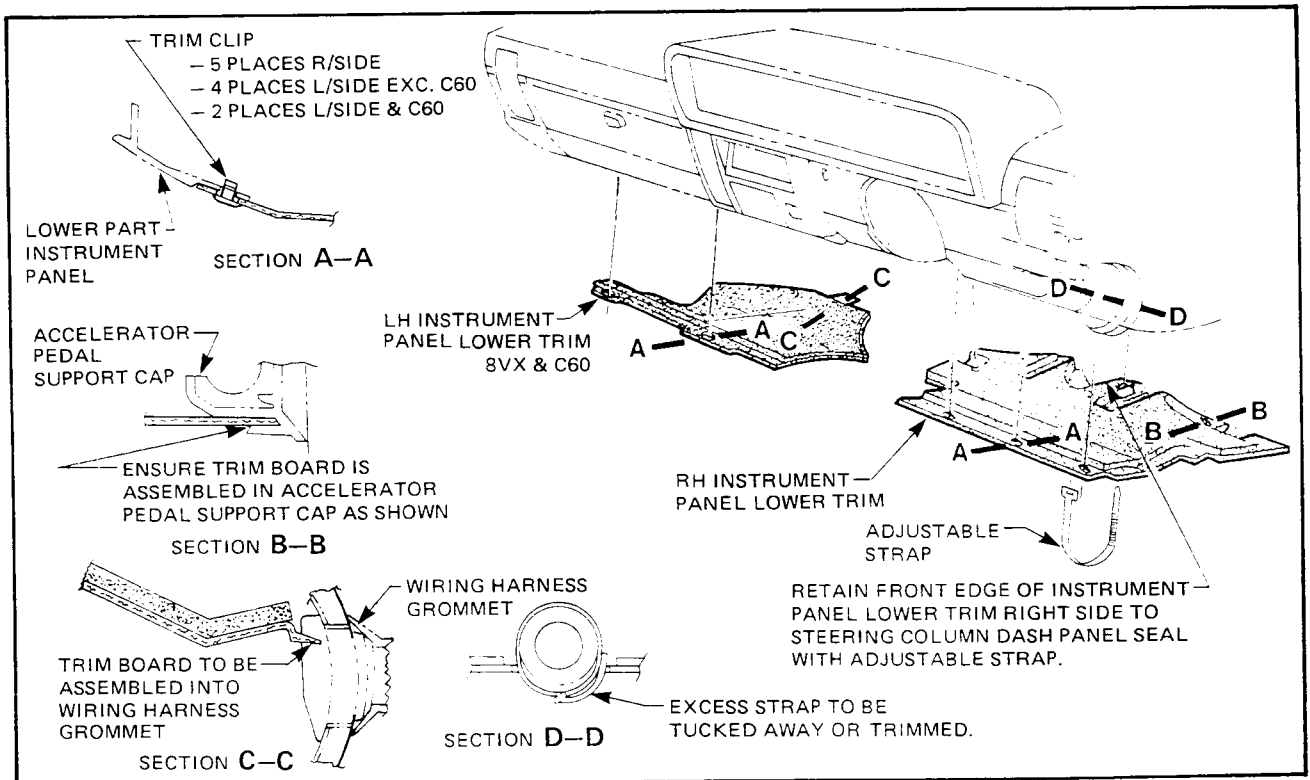

Figure 1A-8

1A-10 BODY

3.3 INSTRUMENT PANEL PAD

REMOVE

1. Disconnect battery ground cable.
2. Remove screw attached lower cover from upper section of steering column (refer Fig. 1A-9).
3. Remove screws securing instrument frame, centre air outlet nozzle and touch panel from instrument cover, disengage electrical connectors from main wiring harness (refer Fig. 1A-10) then remove frame assembly.
4. Remove screws securing top of instrument panel lower extension to base of instrument location cover (refer Fig. 1A-10).
5. Remove screws securing combined instrument assembly to instrument location cover (refer Fig. 1A-11) ease assembly rearward then disengage electrical connectors and on all models, except those with electronic instruments, the speedo cable from speedo head (refer View A, Fig. 1A-11) then remove instrument assembly.
6. Remove instrument location cover (refer Fig. 1A-11) front radio speaker grille and speaker assembly (refer View B, Figs. 1A-12 and 1A-13).
7. Using a fine bladed screwdriver, carefully prise right hand and left hand upper and lower inserts from within side vent upper outlet assemblies prior to removing screws securing upper air outlet assemblies to instrument panel pad assembly (refer Fig. 1A-14) then remove outlet assemblies.
8. With instrument panel compartment open, remove screws securing rearward edge of instrument panel pad to instrument panel brace (refer Fig. 1A-14).
9. Using a 10 mm socket attached to a ratchet handle, loosen right and centre nuts securing pad assembly to instrument panel brackets (refer Fig. 1A-11). Using the same tool with a 630 mm extension installed on the left hand attaching nut (use left hand upper air outlet aperture to gain access) loosen off left hand nut.
10. Ease pad rearwards, disengaging pad studs from instrument panel slotted brackets. With left hand of instrument panel pad raised, remove pad assembly from vehicle.

REINSTALL

Reverse removal operations, including try-out of electrical circuits, air ducting, vacuum hoses and temperature control cable disturbed during removal operations.

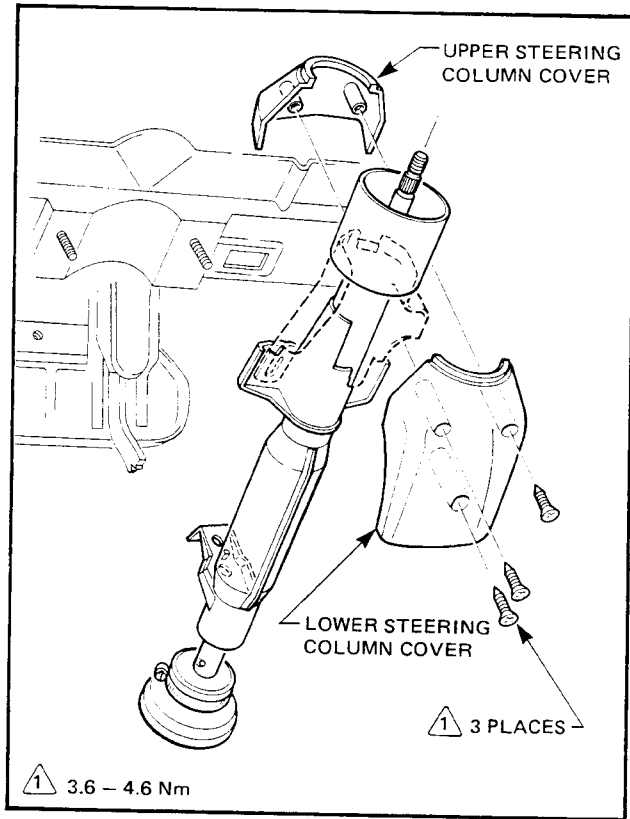

Figure 1A-9

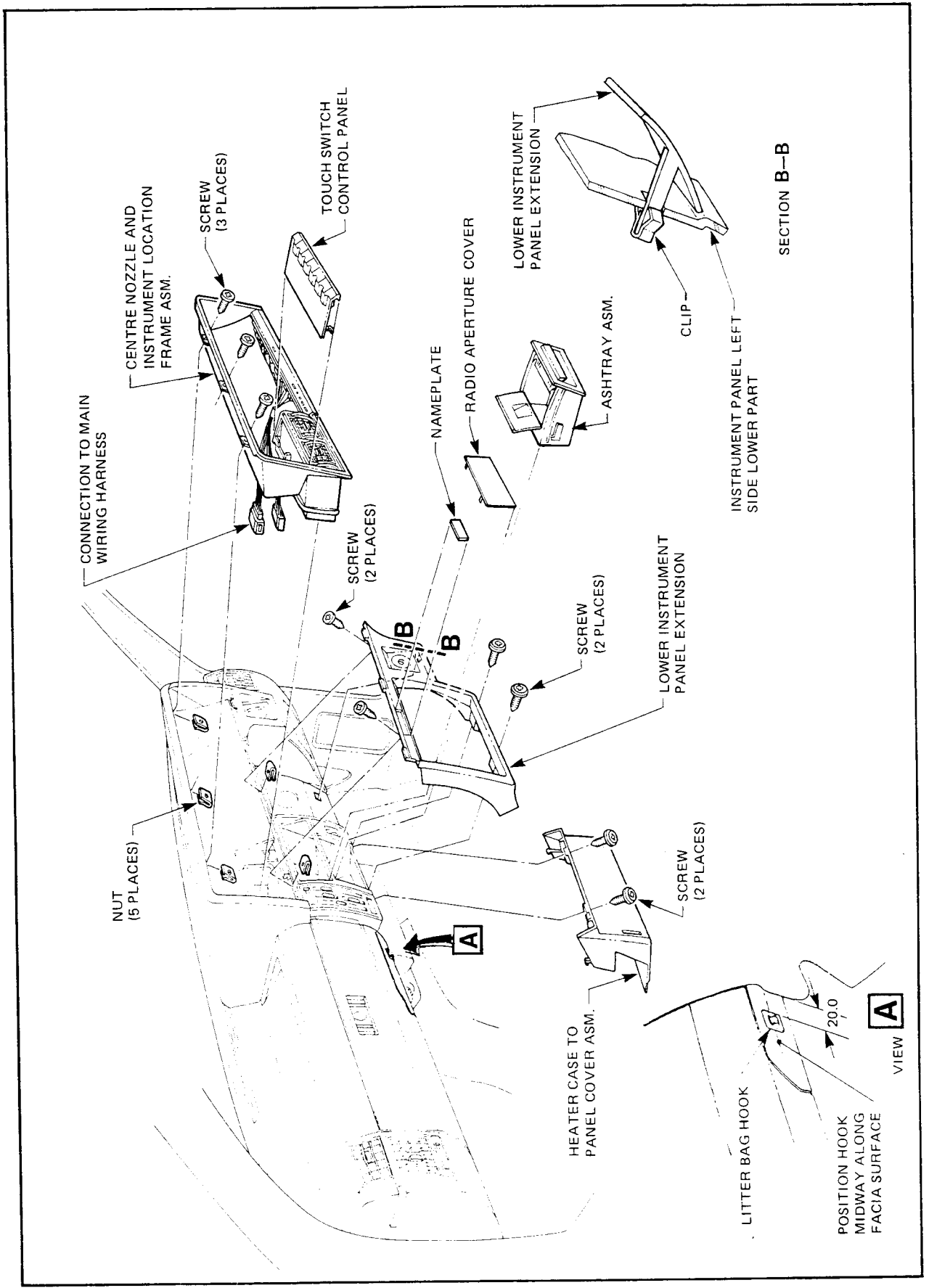

Figure 1A-10

1A-12 BODY

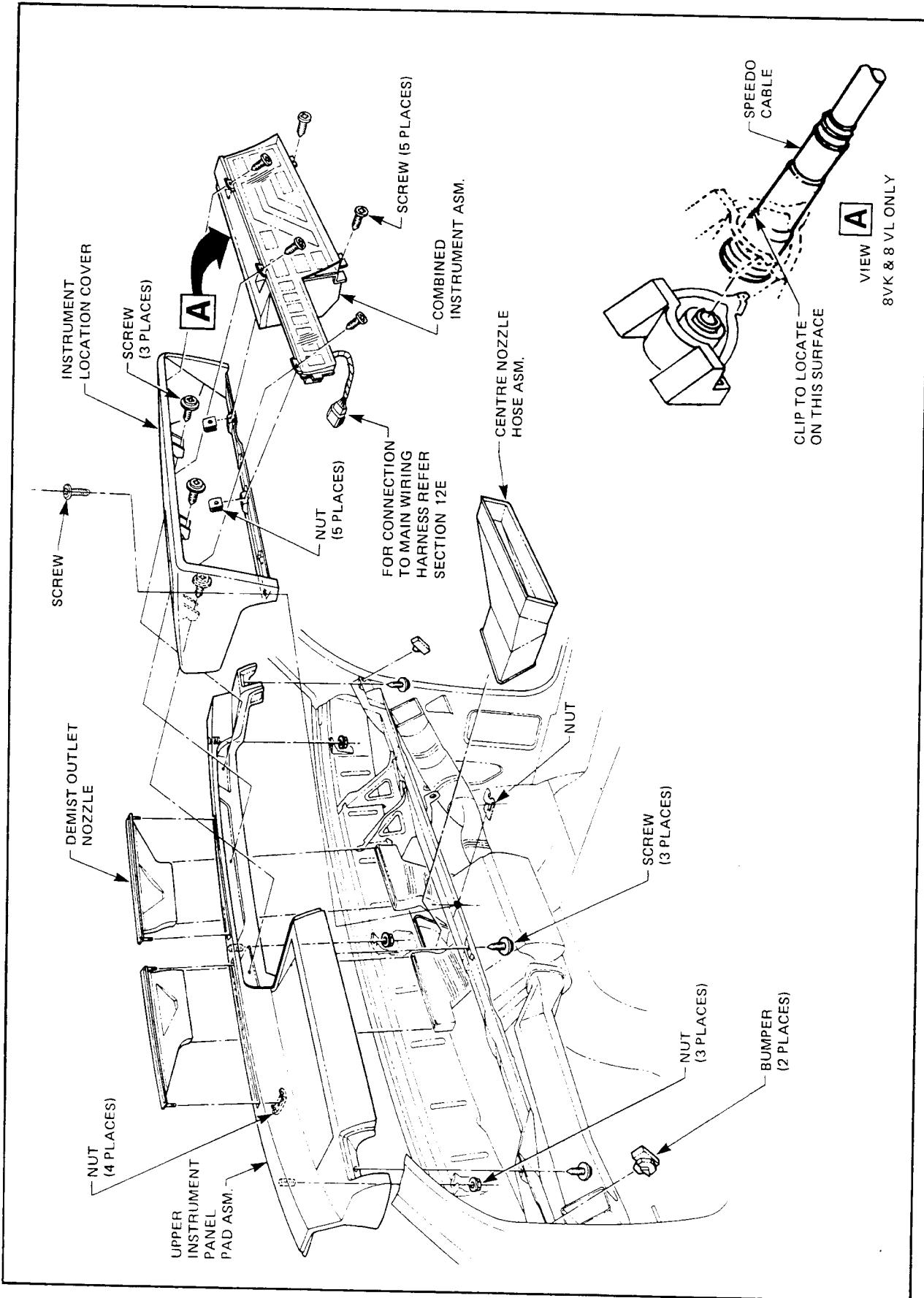

Figure 1A-11

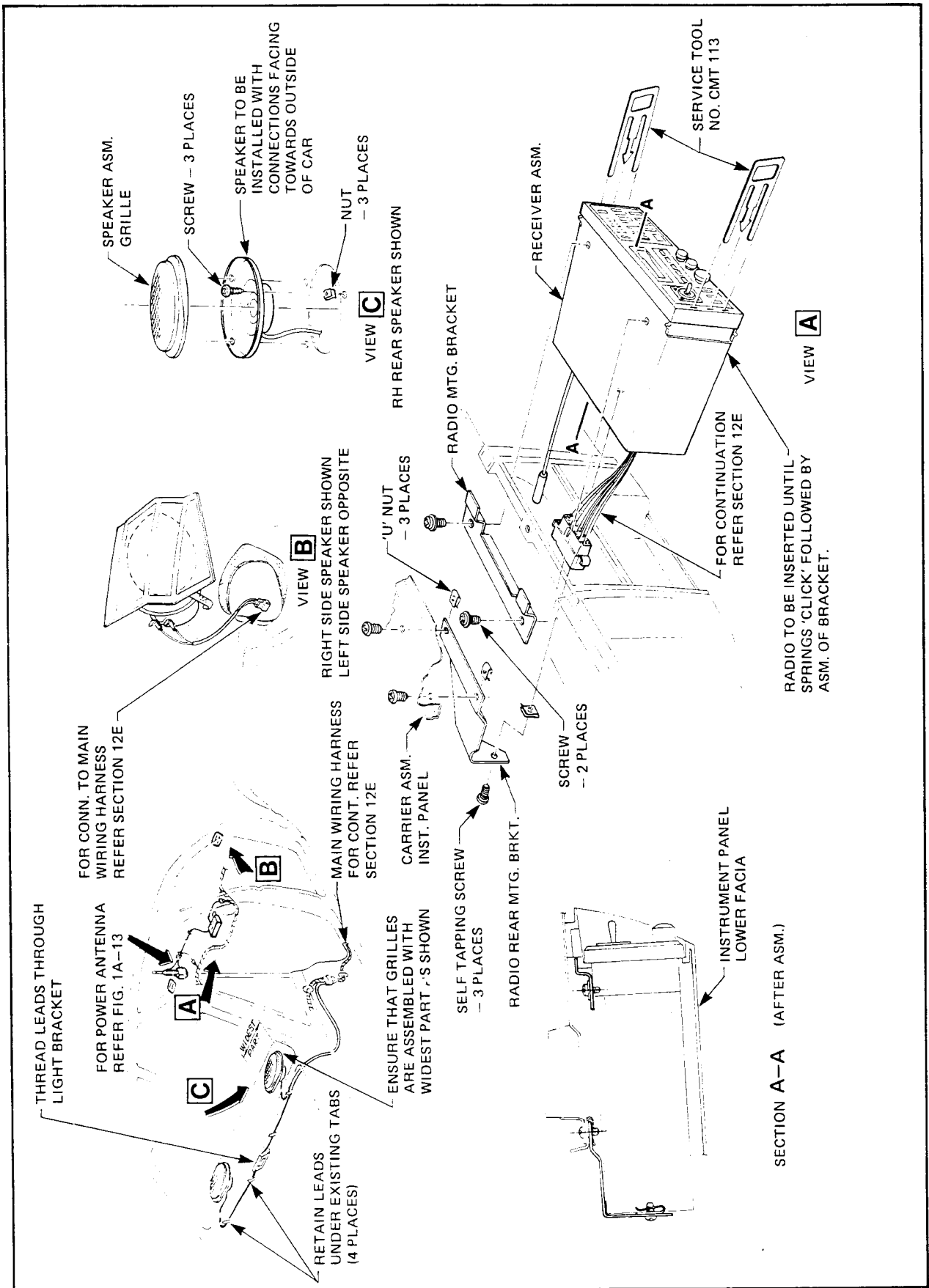

Figure 1A-12

1A-14 BODY

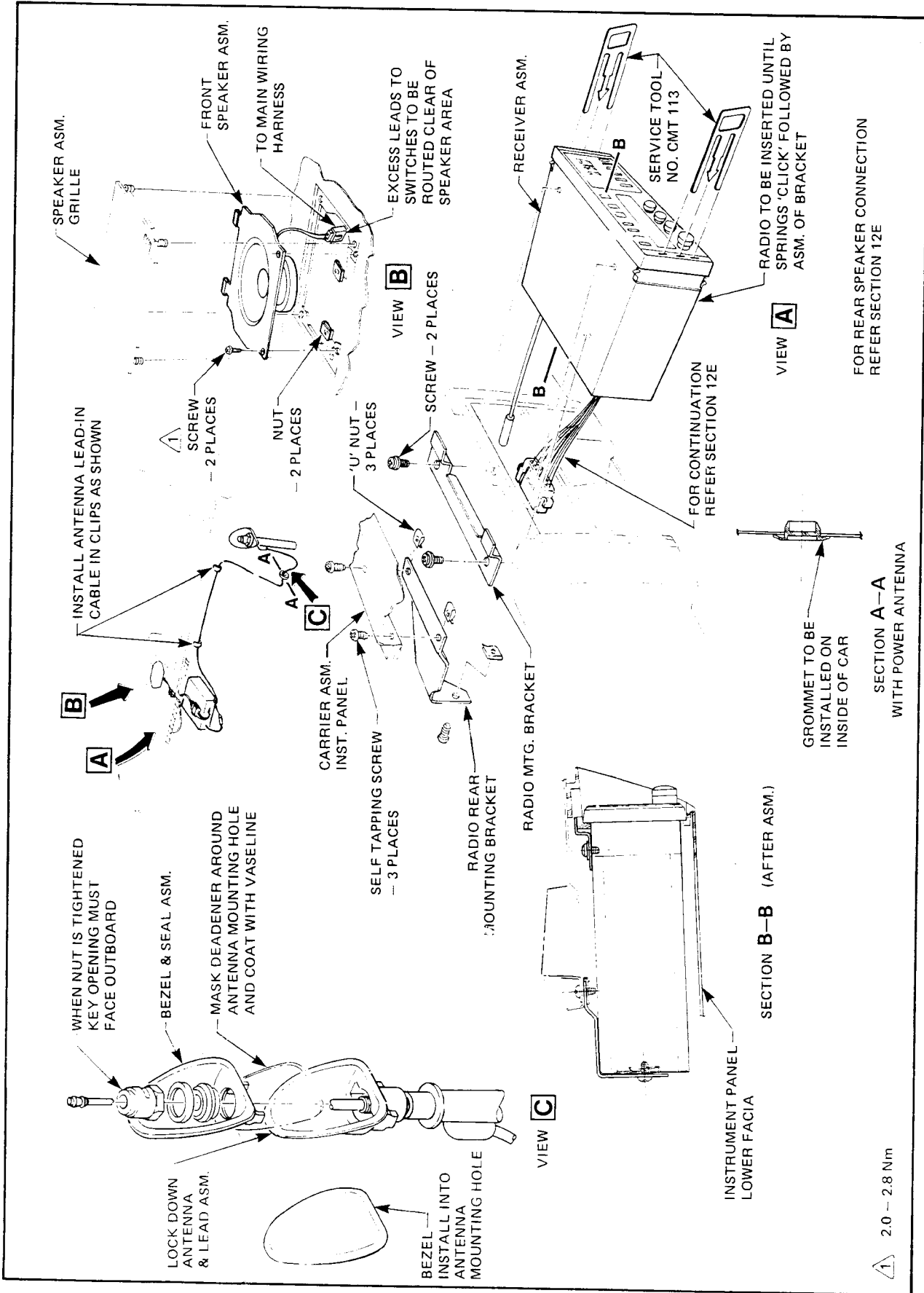
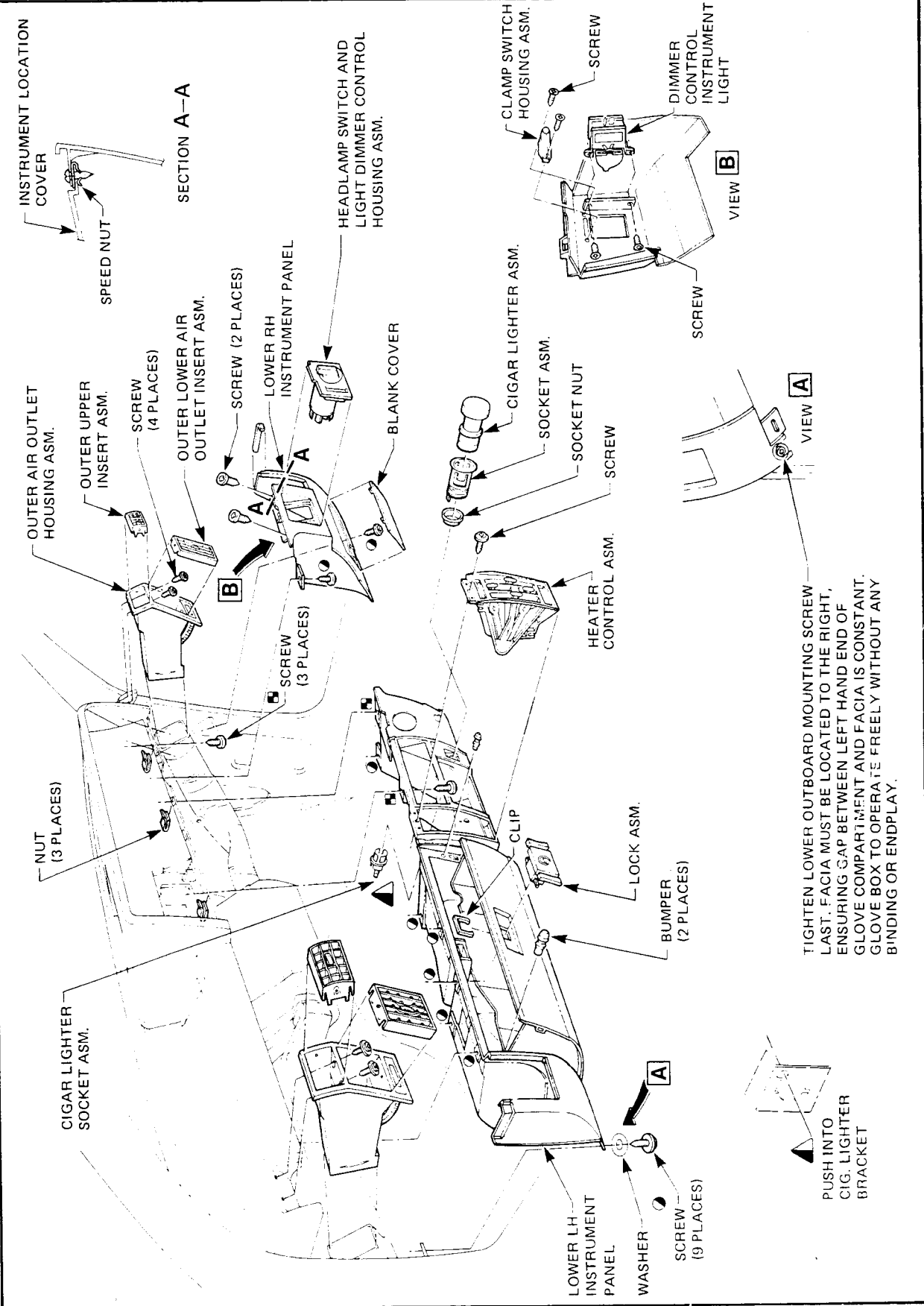

Figure 1A-13



TIGHTEN LOWER OUTBOARD MOUNTING SCREW LAST. FACIA MUST BE LOCATED TO THE RIGHT, ENSURING GAP BETWEEN LEFT HAND END OF GLOVE COMPARTMENT AND FACIA IS CONSTANT. GLOVE BOX TO OPERATE FREELY WITHOUT ANY BINDING OR ENDPLOY.

PUSH INTO CIG. LIGHTER BRACKET

Figure 1A-14

1A-16 BODY

3.4 INSTRUMENT PANEL LOWER - RIGHT HAND

REMOVE

1. Disconnect battery ground cable.
2. Remove screws securing instrument frame, centre air outlet nozzle and touch panel from instrument cover (refer Fig. 1A-10), disengage electrical connectors from main wiring harness then remove frame assembly.
3. Using a fine bladed screwdriver, carefully prise out right hand upper and lower inserts from within side vent upper outlet assembly. Remove screws securing upper air outlet assembly to instrument panel pad (refer Fig. 1A-14) then remove outlet assembly.
4. Remove screw attached lower cover from upper section of steering column (refer Fig. 1A-9).
5. From under right hand side of instrument panel, disengage electrical connectors from rear of light switch and dimmer control, vacuum hoses and temperature control cable, remove panel cover, then screws securing right hand instrument panel lower to base of instrument location cover (refer View 'B' and Section A-A, Fig. 1A-14) then remove instrument panel lower.
6. Using a wide bladed screwdriver, carefully prise headlamp switch and dimmer control housing, then dimmer control from right hand instrument panel lower.

REINSTALL

Reverse removal operations, including try-out of electrical circuits, air ducting, vacuum hoses and temperature control cable disturbed during removal operations.

3.5 INSTRUMENT PANEL LOWER - LEFT HAND, INCLUDING RADIO AND RADIO/CASSETTE PLAYER RECEIVER

REMOVE

1. Disconnect battery earth cable.
2. Remove transmission console (refer 2.2 or 2.3 in this Section).
3. Remove heater case to panel cover assembly (refer Fig. 1A-10).
4. Remove left hand instrument panel lower trim (refer Section A-A, Fig. 1A-8).
5. With instrument panel compartment open and with the blade of a screwdriver located between head of hinge pin and right hand compartment side, prise out hinge pin compartment (refer Fig. 1A-15) then remove compartment.
6. Remove left hand shroud lower trim (refer 2.4 in this Section).
7. Remove left hand upper side vent outlet (refer 3.4 in this Section).
8. Remove touch switch control panel and electrical connector (refer Fig. 1A-10).
9. Remove screws securing the centre nozzle and instrument location frame assembly (refer Fig. 1A-10) disengage electrical connectors from front end wiring harness, then remove frame assembly.

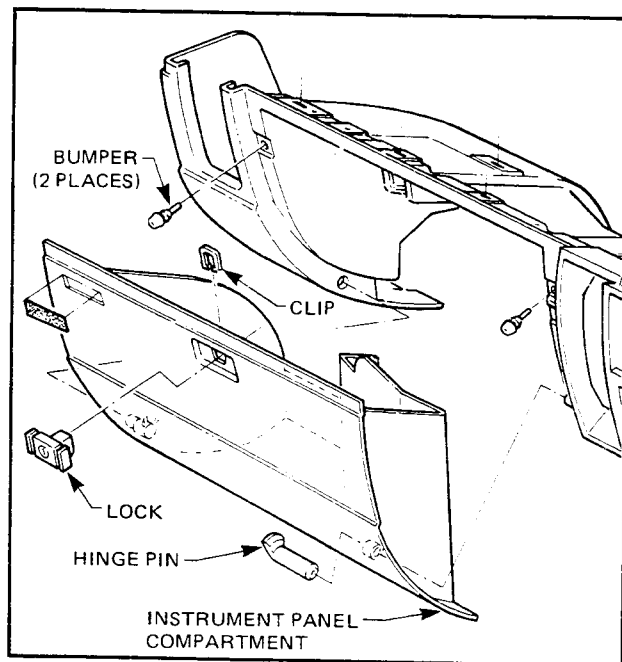

Figure 1A-15

4. REAR QUARTER

INDEX

Ref.	Subject	Page	Ref.	Subject	Page
4.1	QUARTER WINDOW INNER UPPER TRIM	1A-19		Remove	1A-19
	Models - 19 Body Styles	1A-19		Reinstall	1A-20

4.1 QUARTER WINDOW INNER UPPER TRIM

MODELS - 19 BODY STYLES

Remove

1. Depress front edge of rear seat cushion assembly then ease assembly rearwards to disengage assembly retainer from brackets attached to the floor (refer Section A-A, Fig. 1A-16) remove and place assembly onto a clean protected surface.

NOTE: On rear seats fitted with head restraints, it is necessary to remove the head restraints and guide sleeves (refer 6.4 in this Section) prior to removal of rear seat back assembly.

2. Unclinch tabs securing seat back frame to rear wheel-houses (refer View A, Fig. 1A-16).
3. Lift seat back frame from retaining brackets attached to the rear compartment front panel (refer Section B-B, Fig. 1A-16) then place rear seat back assembly onto a clean protected surface.

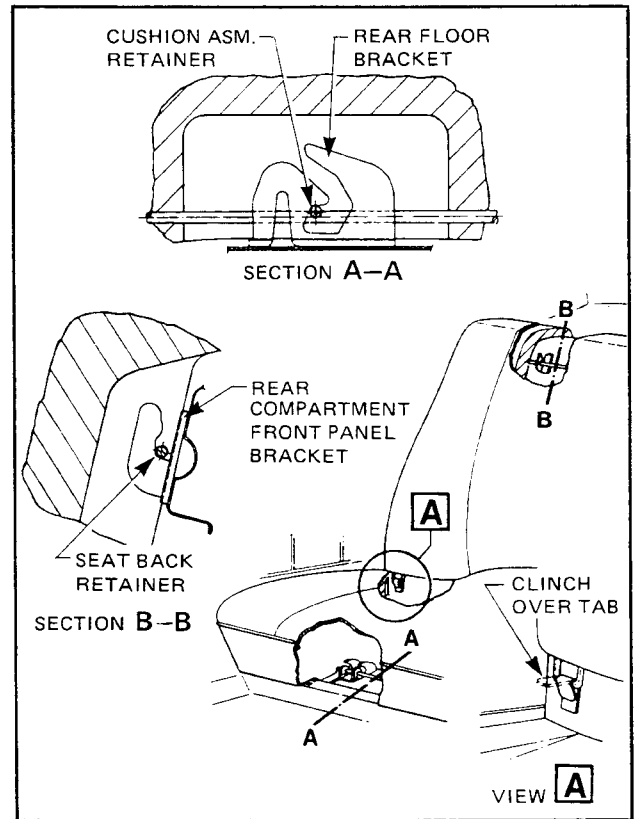

Figure 1A-16

4. Remove rear seat belt upper attachment (refer Section B-B, Fig. 1A-17).

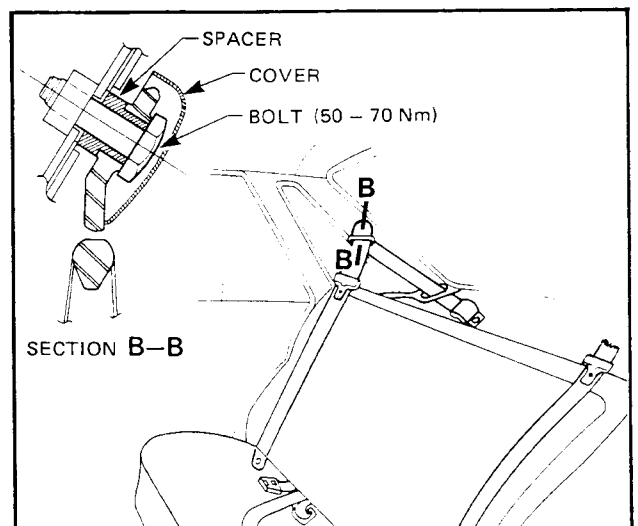

Figure 1A-17

1A-20 BODY

- From inside rear compartment, tap out fasteners securing trim to rear parcel shelf (refer Section A-A, Fig. 1A-18) on side from which quarter window trim is to be removed.

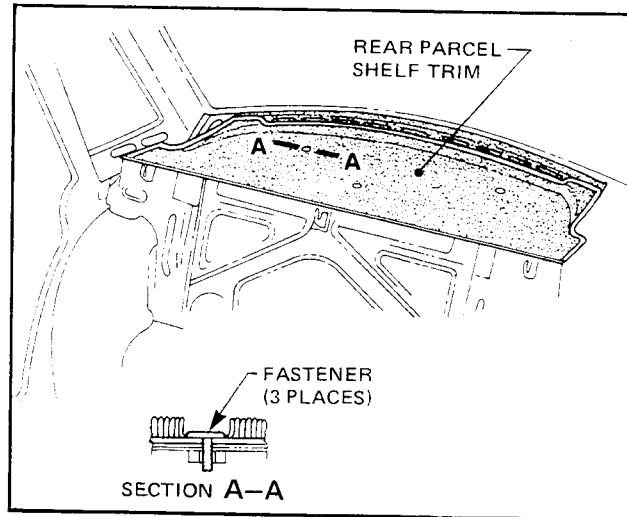

Figure 1A-18

- Ease rear door opening finishing lace from leading edge of quarter window inner upper trim, then using a broad bladed screwdriver located between trim and quarter inner panel, adjacent to trim fasteners (refer Sections A-A and B-B, Fig. 1A-19) carefully prise fasteners and trim from rear quarter inner upper panel.

Reinstall

Reverse removal operations.

NOTE: Damaged barbs on trim panel fasteners require fastener replacement.

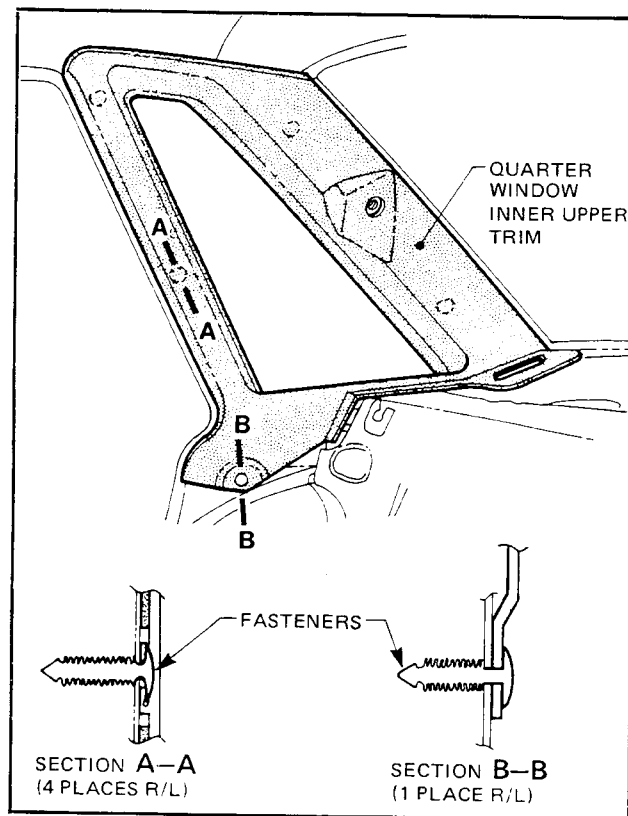

Figure 1A-19

5. STATIONARY GLASS

INDEX

Ref.	Subject	Page	Ref.	Subject	Page
5.1	DESCRIPTION	1A-21	5.4	TAILGATE WINDOW	1A-28
5.2	SERVICE NOTES	1A-21		Minor Water Leak Correction.....	1A-28
5.3	REAR QUARTER WINDOW ASSEMBLY	1A-22		Short Method	1A-28
	Models - 19 Body Styles	1A-22		Remove.....	1A-28
	Remove.....	1A-22		Reinstall	1A-28
	Quarter Window Aperture Check	1A-23		Long Method.....	1A-29
	Reinstall	1A-23		Remove.....	1A-29
	Short Method.....	1A-23		Reinstall	1A-29
	Long Method	1A-25			

5.1 DESCRIPTION

Toughened glass is fitted to rear quarter apertures on 19 body styles and to tailgates on 35 body styles.

These glasses are bonded to the rear quarter upper panel and tailgate aperture flanges with a self curing metal to glass urethane adhesive.

In situations necessitating complete removal of the original urethane, such as damage to window apertures where paint finish or base metal is exposed, a urethane adhesive kit has been developed and must be used to maintain the original structural specifications.

Part No. 92018612 'Long Method'. The repair kit for this operation contains:

- 300 ml Urethane Adhesive.
- 25 ml Glass Primer - Clear.
- 25 ml Glass Primer - Black.
- 25 ml Body Primer. 435-56
- Necessary applicators.
- Instructions.

NOTE: For tailgate window replacement - Long Method, an additional auxiliary kit, Part No. M39097, which contains 300 ml of urethane adhesive, is required.

ADDITIONAL COMPONENTS REQUIRED (Not part of package)

Appropriate mouldings as required.

A second method for window replacement referred to as the 'Short Method' is used when original urethane adhesive left intact on the window aperture flanges after glass removal can serve as a satisfactory base for the reinstallation of the original or new glass. This would occur when the glass is being removed to overcome a severe water leak, or when a glass is broken.

The repair kit developed to service this Short Method or Minor Water Leak correction is part number 92018611 and contains:

- 300 ml Urethane Adhesive.
- 25 ml Clear Glass Primer.
- 25 ml Glass Black Out Primer.
- Necessary Applicators.
- Instructions.

These replacement kits are available from:-

Dimet,
53 Showers Street,
Preston, Vic. 3072.

An additional short method replacement kit which is only recommended for rear quarter windows on sedans, is available from GM P & A under Part No. M38977 and contains 300 ml of silicone.

This material is also recommended for minor water leak correction on all urethane installed stationary glass.

5.2 SERVICE NOTES

WARNING: WORK GLOVES MUST BE WORN AT ALL TIMES WHEN OPERATING WITH GLASS.

NOTE: Skinning (partial curing) of the urethane commences after exposure to the atmosphere. At 23°C and 50% relative humidity, skinning commences after 30 minutes. Therefore, installation of tailgate window mouldings must be completed within that time limit on station wagons.

Complete curing of urethane at this temperature and humidity takes 72 hours.

The recommended tool for cutting through the urethane is the glass sealant removal Tool No. J24402, which can be obtained from Kent-Moore Australia Pty. Ltd.

1A-22 BODY

5.3 REAR QUARTER WINDOW ASSEMBLY

MODELS - 19 BODY STYLES

Remove

The quarter window glass removal procedure is similar for both the 'Short' and 'Long' Installation Methods with one exception. If the Short Method installation is to be used, more care must be taken during glass removal to ensure that an even bead of urethane adhesive remains on quarter window aperture flanges to serve as a base for the replacement glass.

1. To prevent damage to paint finish and trim and to minimise clean up, mask and place protective covers over parts adjacent to glass.
2. Using fingers or a wide bladed screwdriver, carefully prise off leading edge of roof drip gutter rear moulding from garnish moulding (refer Section AM-AM, Fig. 1A-20).
3. Remove screw securing rear end of quarter reveal moulding lower (refer Section AN-AN, Fig. 1A-20) and remove moulding.

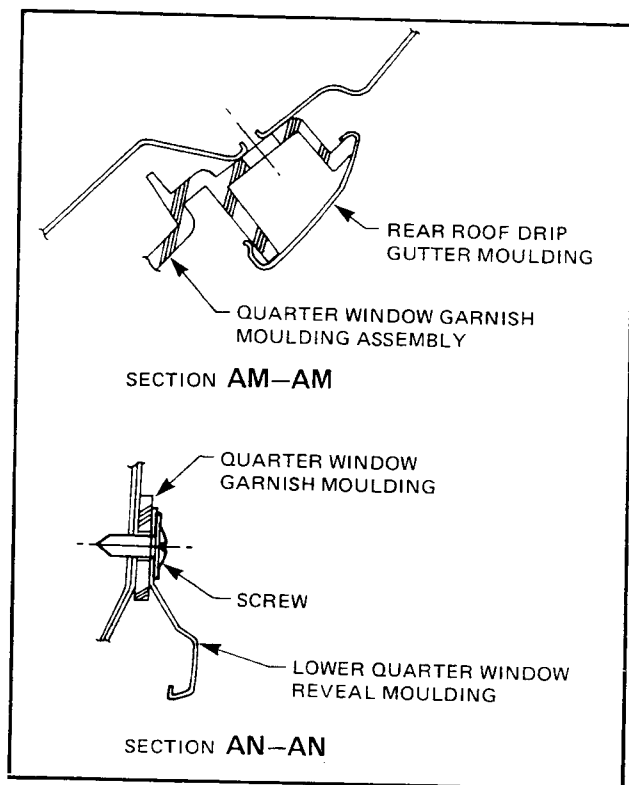

Figure 1A-20

4. Remove remaining screws securing garnish moulding to rear quarter aperture (refer Fig. 1A-21) then remove garnish moulding, which is attached to the outer surface of the glass with four (4) short strips of butyl, centrally spaced at top, bottom and sides of garnish moulding (refer View H, Fig. 1A-22) then remove garnish moulding.

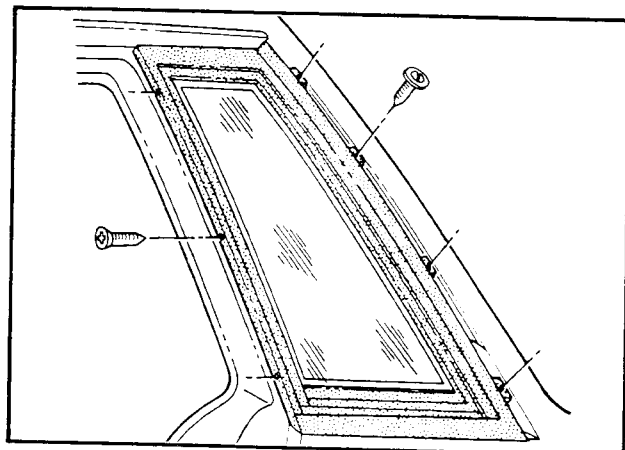

Figure 1A-21

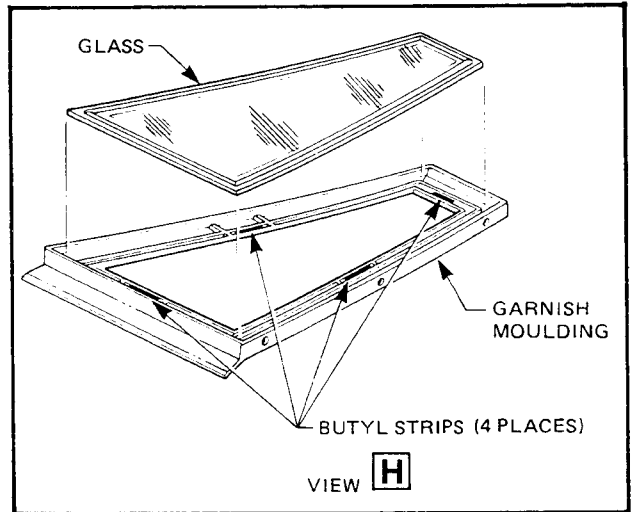

Figure 1A-22

5. Locate blade of Tool No. J24402, glass sealant remover, between inside of glass and urethane as illustrated in Fig. 1A-23, then cut through urethane, around complete periphery of glass.
6. Carefully lift glass out of aperture. If there is evidence of glass adhesion to urethane, re-apply cutting tool to problem area.
7. If original glass is to be reinstalled, place glass on a protected bench or holding fixture and using a sharp scraper, carefully remove original urethane from glass. Clean glass with a suitable oil-free cleaning agent such as Prepsol or equivalent.

NOTE: Do not use petroleum base solvents to clean glass or aperture flange as the presence of oil will prevent the adhesion of new urethane/silicone.

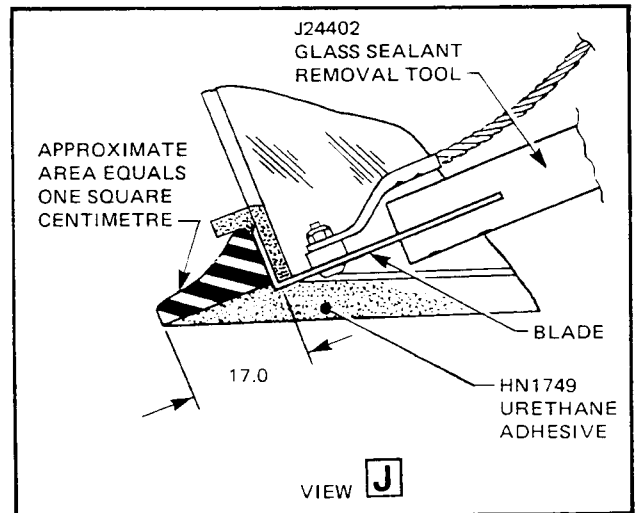

Figure 1A-23

QUARTER WINDOW APERTURE CHECK

Thoroughly check rear quarter window aperture flange to ensure that no surface irregularities exist. Correct any that do. If 'Short Method' glass installation is being used, check original urethane on flange for looseness or voids. Where these exist, cut away any loose urethane and fill in any voids or unevenness in bead, using urethane/silicone.

Reinstall

Short Method

1. Short Method installation of rear quarter glass is used where the maximum amount of original urethane adhesive is left intact on the body opening to form a base for the replacement glass. This method should be used when replacing a cracked glass or leak condition that cannot be overcome by using minor water leak repair procedures. Any previous service installation using other adhesive materials requires complete replacement of material to achieve an effective glass to metal bond.

1A-24 BODY

2. Thoroughly clean surface of glass to which new urethane/silicone is to contact (including edge of glass). Use clean cloths with a suitable oil-free cleaning solvent, such as Prepsol or equivalent.

URETHANE ONLY

3. Using an applicator in Kit, apply HN1747 (clear glass primer) around entire perimeter of glass edge and 12 mm in from edge of glass. This is a wipe on/wipe off operation, using clean lint free cloths (refer View E, Fig. 1A-24).

URETHANE ONLY

4. Using a second applicator, apply HN1748 (black-out glass primer) around entire perimeter of glass edge and on glass bonding surface (refer View G, Fig. 1A-24). Allow primer to dry for 15 minutes. Avoid touching primed area of glass.
5. Install glass with its inner surface facing upwards into garnish moulding as illustrated in View H, Fig. 1A-24, then firmly press glass onto butyl strips located on garnish moulding recess.
6. Apply a smooth continuous bead of urethane/silicone between centre and outer edge on top of original urethane and around entire perimeter of body opening. Silicone bead should be a minimum of 6 mm in diameter.
7. Install glass and garnish moulding assembly into rear quarter window aperture, applying sufficient pressure on assembly to evenly distribute silicone between glass and aperture flange to effect a watertight seal.

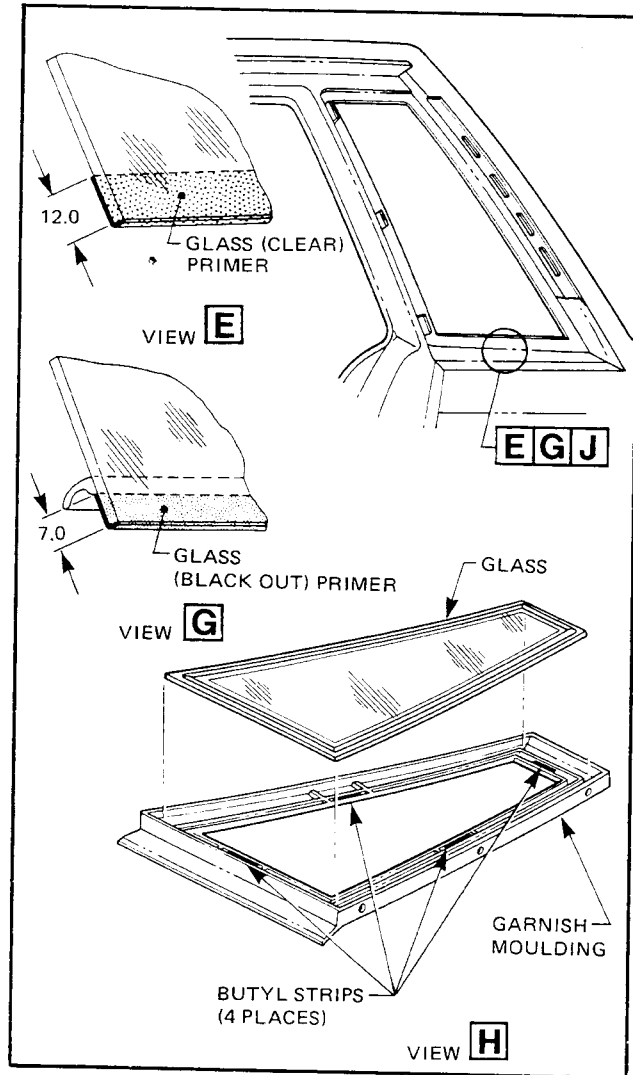

Figure 1A-24

8. Install screws securing garnish moulding to the top and sides of the window aperture (refer Fig. 1A-25).
9. Water leak test quarter window using a moderate spray of water.

NOTE: Do not direct a heavy stream of water onto freshly applied silicone. If water leak is evident, remove garnish moulding and apply additional silicone to leak area, using a flat bladed tool to work fresh silicone into the source of the leak, then install garnish moulding.

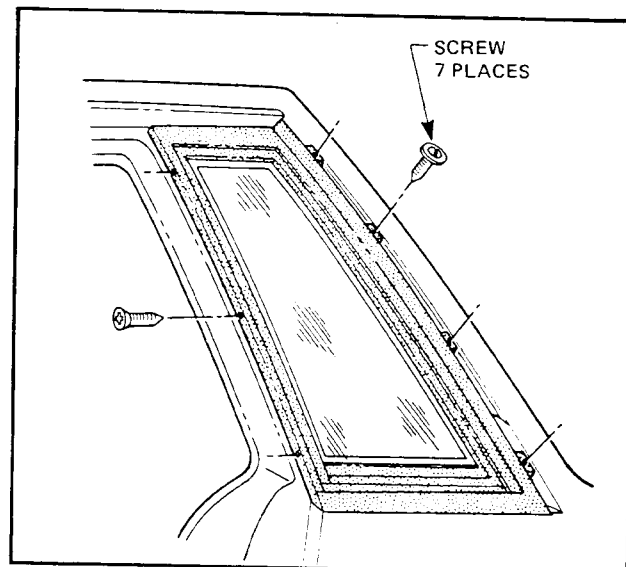

Figure 1A-25

10. Install screw attached quarter reveal moulding lower to lower section of garnish moulding (refer Section AN-AN, Fig. 1A-26).
11. Locate hooked edge of roof drip gutter rear moulding over rearward outer edge of garnish moulding, then with the hand, lightly tap opposite side of moulding over garnish moulding (refer Section AM-AM, Fig. 1A-26).
12. Remove paint and trim protective masking tape and covers.

NOTE: White spirit is recommended for removal of silicone from paint finish and trim.

Long Method

The long method of glass replacement is used when original urethane adhesive material cannot serve as a base for replacement glass.

This method should be used on vehicles requiring metal or paint repair to the quarter window aperture flange when original adhesive is completely removed and replaced with new urethane for glass installation.

This method is also used when the quarter window has been previously replaced, using the Short Method. In such instances, the build-up of urethane/silicone could position the glass too far out of the opening.

1. Using the glass sealant removal tool and/or sharp scraper, remove original urethane from around entire perimeter of quarter window aperture flange.
2. Using an applicator supplied in 'Long Method' Replacement Kit No. 92023123, apply HN1752 (Flange primer) to any section of the quarter window aperture flange that is back to bare metal or has been cleaned back to original paint surface (refer Views A, B, C & D, Fig. 1A-27). Allow primer to dry for 30 minutes. Avoid touching primed area.

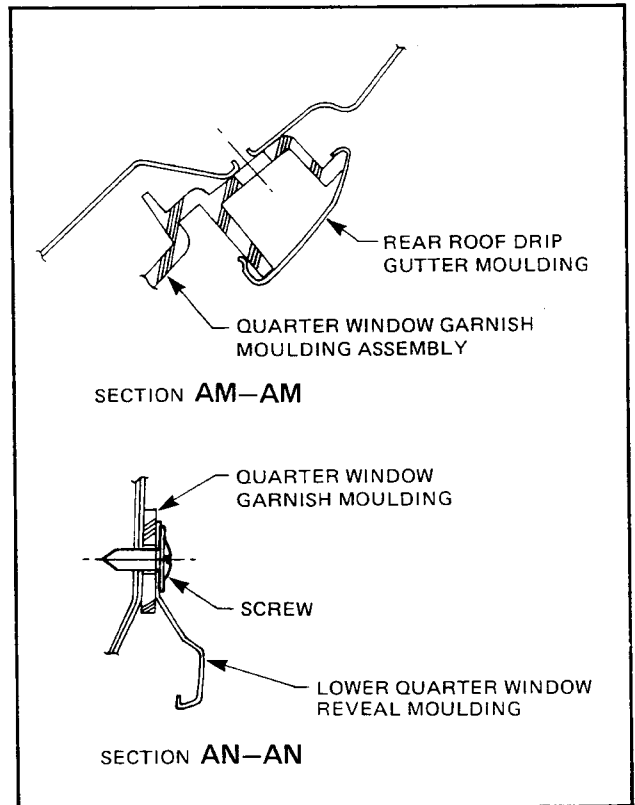

Figure 1A-26

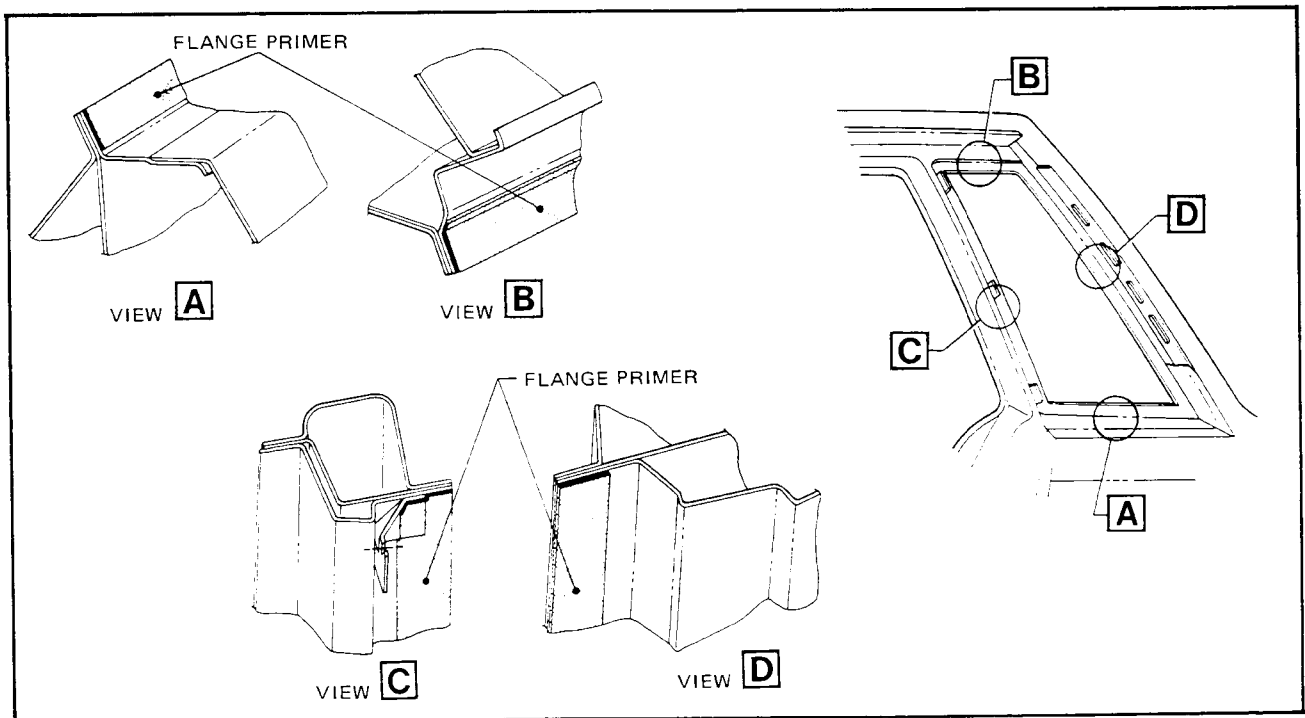

Figure 1A-27

1A-26 BODY

3. Thoroughly clean inner surface of glass to which urethane is to be applied as well as around complete edge of aperture flange. Use clean cloths with suitable oil-free cleaning solvent such as Prepsol or equivalent.
4. Using an applicator in Long Method Kit, apply HN1747 (clear glass primer) around entire perimeter of glass edge and 12 mm in from edge of glass. This is a wipe on/wipe off operation, using clean lint free cloths (refer View E, Fig. 1A-28).
5. To maintain appearance and minimise clean up, install a foam sealing dam, Part Number 92018138 to glass. Commencing at either lower corner of glass, locate dam around entire perimeter of glass, 7 mm from edge on inner surface (refer View F, Fig. 1A-28).

NOTE: A suitable gauge to maintain the dam 7 mm from edge of glass can be readily fabricated by cutting a 7 mm notch in a piece of wood. Locate the 7 mm dimension of the gauge onto the inner surface of the glass, locating the outside edge of the dam on the end of the 7 mm dimension.

6. Using a second applicator, apply HN1748 (black-out glass primer) around entire perimeter of glass edge and on glass bonding surface (refer View G, Fig. 1A-29). Allow primer to dry for 15 minutes. Avoid touching primed area of glass.
7. Tidy up strips of butyl centrally located on top, bottom and on both sides of garnish moulding (refer View H, Fig. 1A-29).
8. Install glass with its inner side facing upwards into garnish moulding as illustrated in View H, Fig. 1A-29. Firmly press glass onto butyl strips located at four places on garnish moulding recess.
9. Using a hand operated applicator with special nozzle supplied in kit, apply a smooth continuous bead of HN1749 urethane adhesive, 17 mm high and 7 mm at base, around entire perimeter of inner surface of glass (refer View J, Fig. 1A-29).

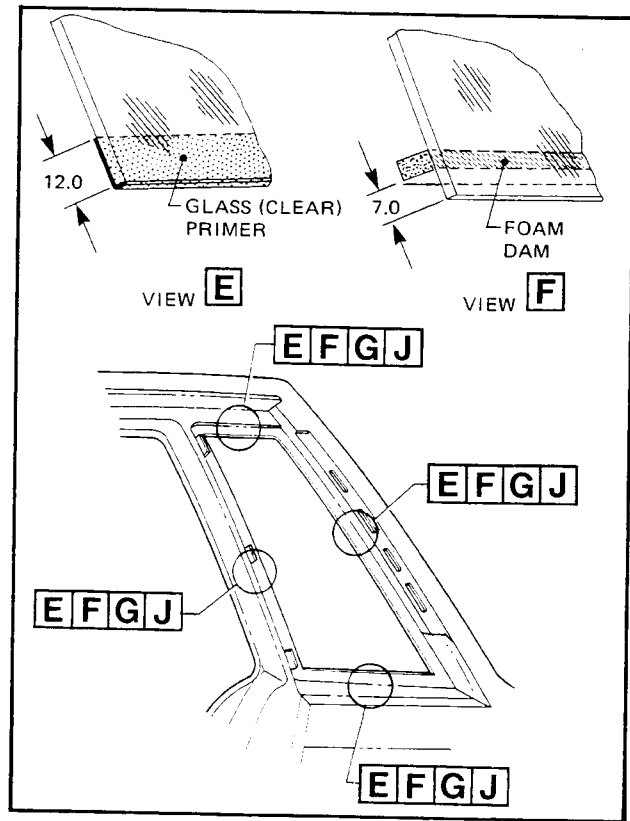

Figure 1A-28

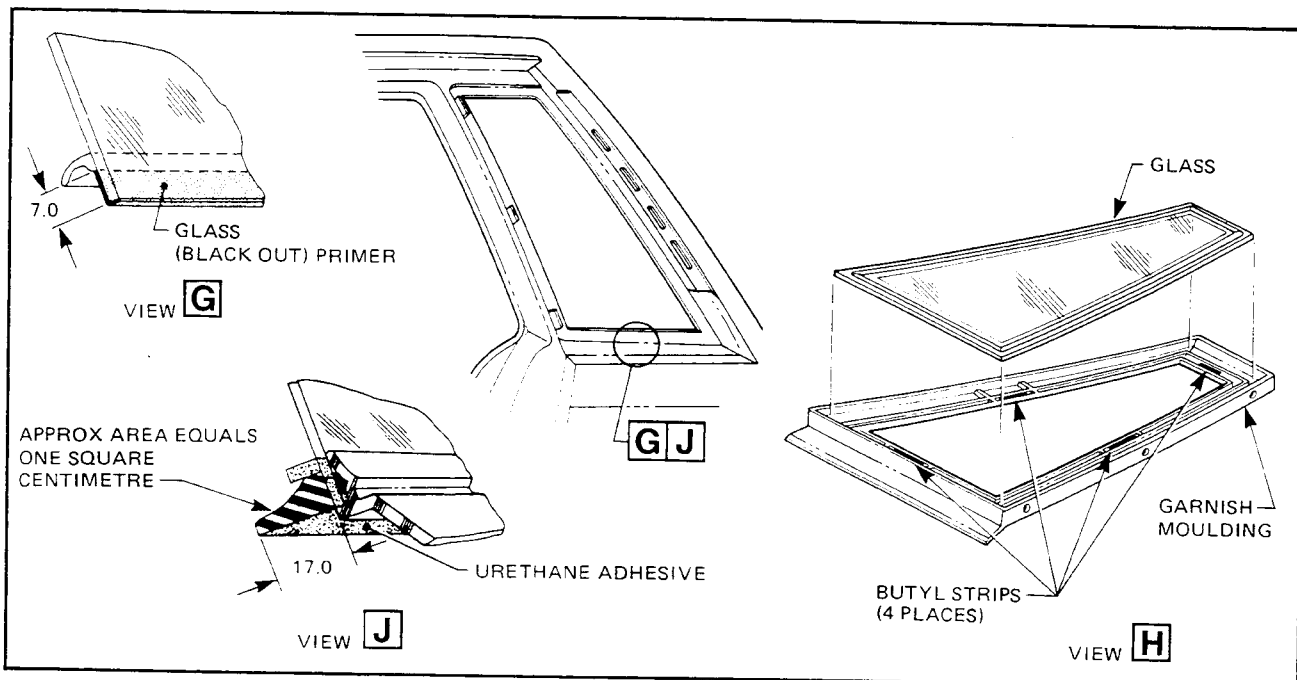

Figure 1A-29

NOTE: In cold weather, the placement of cartridges adjacent to a source of warmth, will assist the flow of urethane when using a hand applicator.

10. Install glass and garnish moulding assembly into rear quarter window aperture (refer Views K and L, Fig. 1A-30) applying sufficient pressure on assembly to evenly distribute urethane between glass and aperture flange to effect a watertight seal.
11. Install screws securing garnish moulding to top and sides of the quarter window aperture (refer Fig. 1A-30).
12. Water test quarter window using a moderate spray of water.

NOTE: Do not direct a heavy stream of water onto freshly applied urethane. If a water leak is evident, remove garnish moulding and apply additional urethane to the leak area, using a flat bladed tool to work urethane into source of leak, then install garnish moulding.

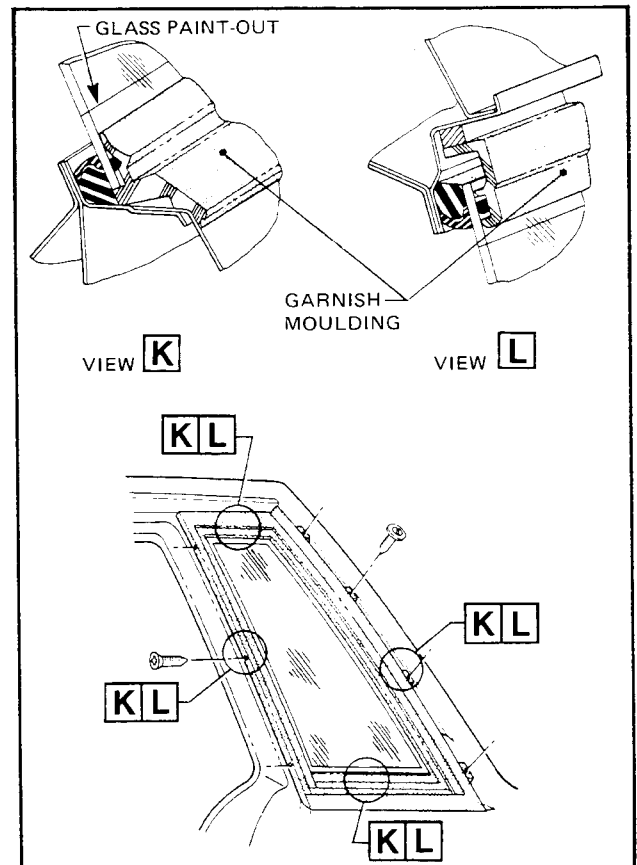

Figure 1A-30

13. Install screw attached quarter reveal moulding lower to bottom horizontal part of garnish moulding (refer Section AN-AN, Fig. 1A-31).
14. Locate hooked edge of roof drip gutter rear moulding over rearward outer edge of garnish moulding, then with the hand, lightly tap opposite side of moulding over garnish moulding (refer Section AM-AM, Fig. 1A-31).

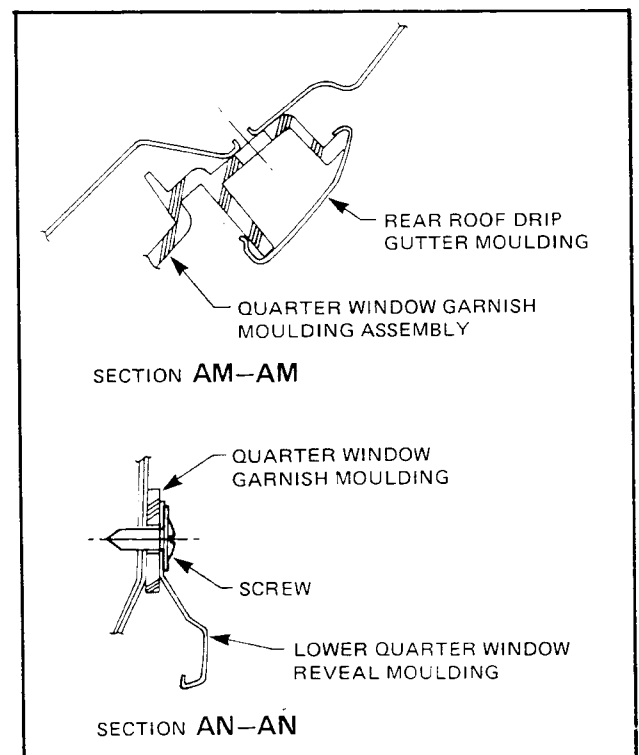

Figure 1A-31

1A-28 BODY

5.4 TAILGATE WINDOW

MINOR WATER LEAK CORRECTION

Locate area of leak. Working on inside surface of glass, apply paint scraper or similar wide blade tool between glass and lacing. Gently flex lacing away from glass in area concerned. Clean any foreign material from this area. Apply HN1770 silicone to area concerned to correct leak.

SHORT METHOD

Remove

1. Disconnect battery ground cable and on Berlina model, remove tailgate window wiper arm and blade assembly and electrical demist connector.
2. Apply protective tape to paintwork adjacent to mouldings as shown in View A, Fig. 1A-32, and place protective covering adjacent to glass.
3. Remove moulding system:-
 - a. Side mouldings - Insert a paint scraper or similar wide blade tool between moulding and body. Apply a rolling action towards the glass as shown in View A, Fig. 1A-33, over full length of moulding to loosen, carefully remove moulding intact for reuse.
 - b. Upper and lower mouldings - Method as for side mouldings.
4. Remove all glass fragments from original glass adhesive leaving adhesive intact on tailgate.
5. Using clean, lint free cloths, dampened with an oil free solvent such as Prepsol or equivalent, thoroughly clean surface of glass which silicone is to contact, including glass edges.

CAUTION: Do not use petroleum based solvents, as the presence of oil will prevent adhesion of the fresh urethane/silicone.

Reinstall

URETHANE ONLY

1. Prime the edge of glass and on the glass bonding surface 12 mm from the edge with glass primer - clear (HN1747). This is a wipe on wipe off operation (refer View B, Fig. 1A-35).

URETHANE ONLY

2. Prime the edge of glass and on the glass bonding surface 7 mm from the edge with glass primer - black (HN1748) and allow to dry for 15 minutes (refer View C, Fig. 1A-35).
3. Apply 6.0 mm bead of urethane/silicone to original adhesive and also to the groove left in the adhesive by the mouldings.
4. With tailgate in near horizontal position fit new glass.
5. Refit upper and lower mouldings.
6. Refit side mouldings.
7. Apply tape to hold mouldings in position where required. This tape to be left on for 24 hours minimum.

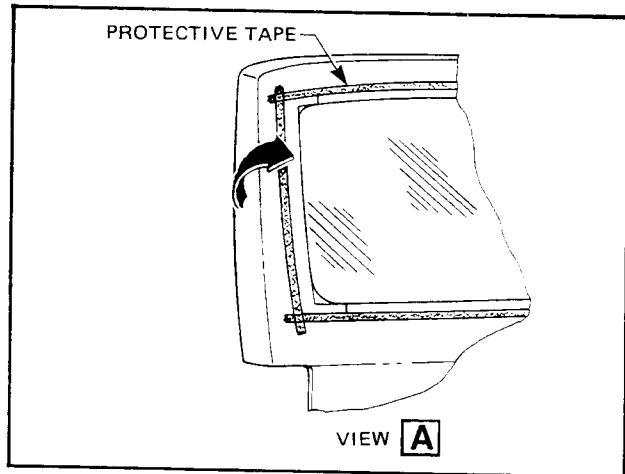

Figure 1A-32

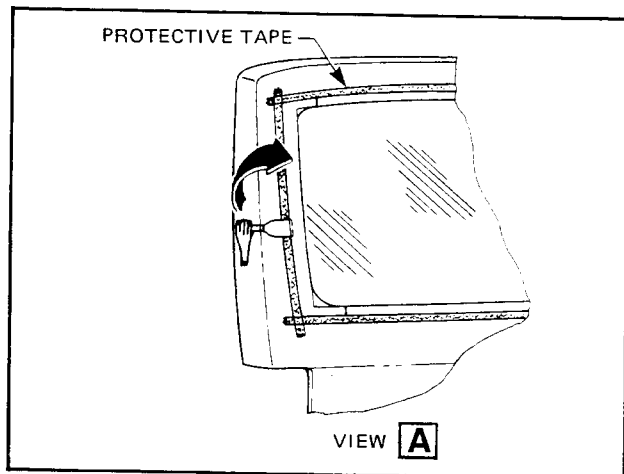

Figure 1A-33

8. Leave tailgate in horizontal position for a minimum of 5 hours, after which time vehicle may be driven providing tailgate is not slammed excessively for 24 hours.
9. On Berlina model, install tailgate window wiper arm and blade assembly and demist electrical connector and on both models, battery ground cable.
10. Remove masking tape from tailgate, clean adjacent paint finish and glass, then remove protective covering from interior.

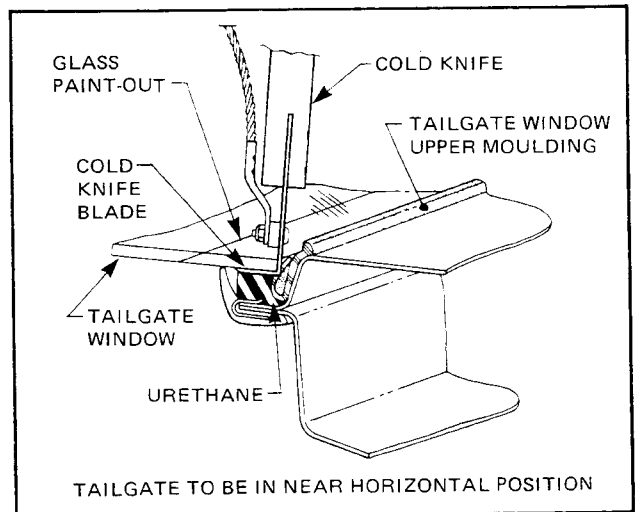

Figure 1A-34

LONG METHOD

Remove

1. Disconnect battery ground cable and on Berlina model, remove tailgate window wiper arm and blade assembly and electrical demist connector.
2. Apply protective tape to paintwork adjacent to mouldings as shown in View A, Fig. 1A-32, and place protective covering adjacent to glass.
3. Remove moulding system:-
 - a. Side mouldings - Insert a paint scraper or similar wide blade tool between moulding and body. Apply a rolling action towards the glass as shown in View A, Fig. 1A-33, over full length of moulding to loosen, carefully remove moulding intact for reuse.
 - b. Upper and lower mouldings - Method as for side mouldings.
4. Remove all glass fragments and urethane, using blade of glass sealant removal Tool No. J24402 illustrated in Fig. 1A-34.

NOTE: It is not necessary to remove all traces of original urethane. However, any remaining urethane must be smooth and firm.

Reinstall

1. Prime body aperture with body primer (HN1752) and allow to dry for 30 minutes (refer View A, Fig. 1A-35).
2. Prime the edge of glass and on the glass bonding surface 12 mm from the edge with glass primer - clear (HN1747). This is a wipe on wipe off operations (refer View B, Fig. 1A-35).
3. Prime the edge of glass and on the glass bonding surface 7 mm from the edge with glass primer - black (HN1748) and allow to dry for 15 minutes (refer View C, Fig. 1A-35).

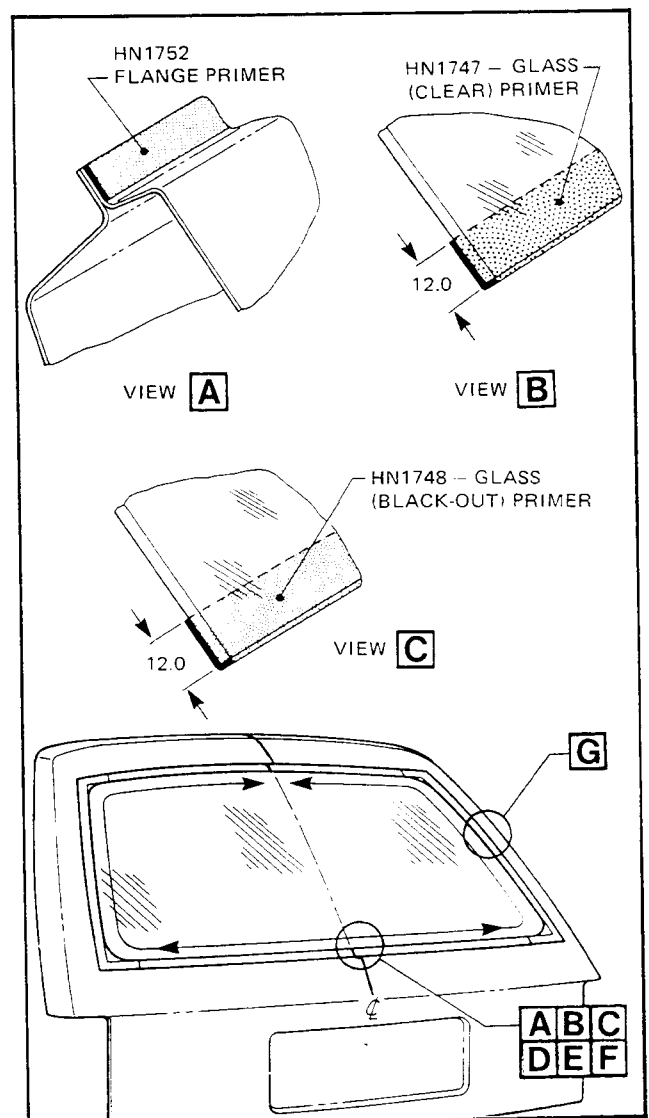

Figure 1A-35

1A-30 BODY

4. Apply an even bead of urethane adhesive (HN1749) 9.0 mm x 7.0 mm to blading flange as shown in View B, Fig. 1A-36, using nozzle cut as shown in View C, Fig. 1A-36).
5. Fit the glass immediately the urethane bead is applied to the body.
6. Immediately the glass is installed, fit moulding system after ensuring that enough urethane is present to bond the mouldings. (Apply additional adhesive to bond mouldings if required.)
7. Apply tape to hold mouldings in position where required. This tape to be left on for 24 hours minimum.
8. Leave tailgate in horizontal position for a minimum of 5 hours, after which the vehicle may be driven providing tailgate is not slammed excessively for 24 hours.
9. On Berlina model, install tailgate window wiper arm and blade assembly and demist electrical connector and on both models, battery ground cable.
10. Remove masking tape from tailgate, clean adjacent paint finish and glass, then remove protective covering from the interior.

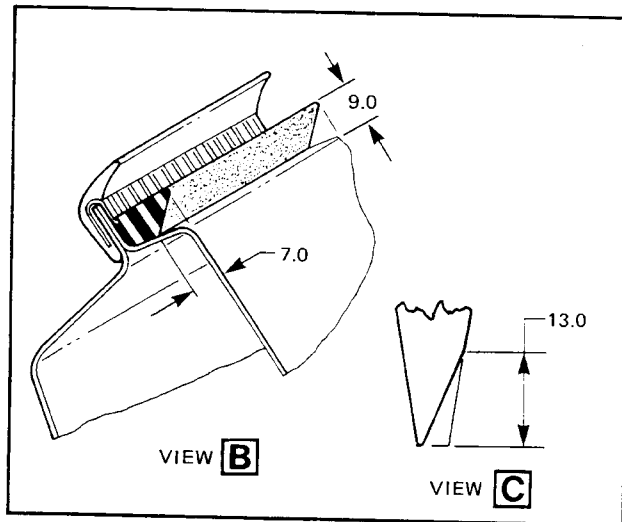

Figure 1A-36

6. SEATS & SEAT BELT ASSEMBLIES

INDEX

Ref.	Subject	Page	Ref.	Subject	Page
6.1	DESCRIPTION	1A-31	6.4	REAR SEAT BELT RETRACTOR ASSEMBLY	1A-34
6.2	LUMBAR SUPPORT - DRIVERS SEAT	1A-31		Remove	1A-34
	Models - Berlina and Calais	1A-31		Reinstall	1A-36
	Remove	1A-31			
	Reinstall	1A-33			
6.3	FRONT SEAT BELT RETRACTOR AND BUCKLE ASSEMBLIES	1A-33			
	Remove	1A-33			
	Reinstall	1A-34			

6.1 DESCRIPTION

New seat trim materials and patterns are released for VK models.

New features on front seats include 'see through' head restraints on all models and on the drivers seat on Berlina & Calais models, a knob operated lumbar support is built into the seat back assembly (refer Fig. 1A-37).

On the Calais model, see through head restraints are fitted to the rear seat backs.

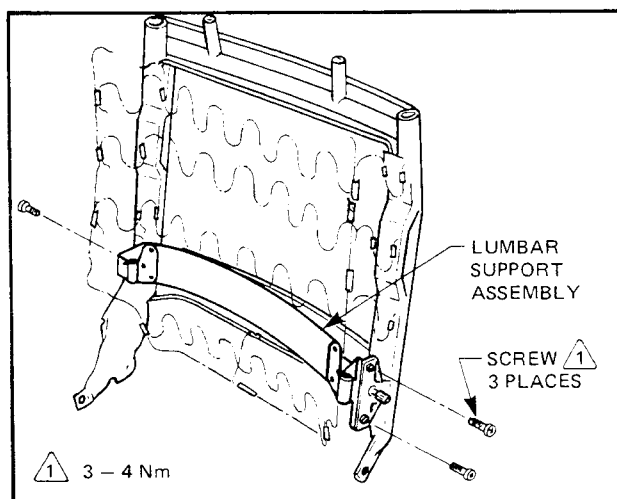

Figure 1A-37

6.2 LUMBAR SUPPORT - DRIVERS SEAT MODELS - BERLINA AND CALAIS

Remove

1. Slide seat fully forward and remove bolts securing rear end of seat adjuster to floor (refer Fig. 1A-38).
2. Slide seat rearward and remove bolts securing front end of seat adjuster.
3. Remove seat from vehicle and place face down on a clean protected surface.

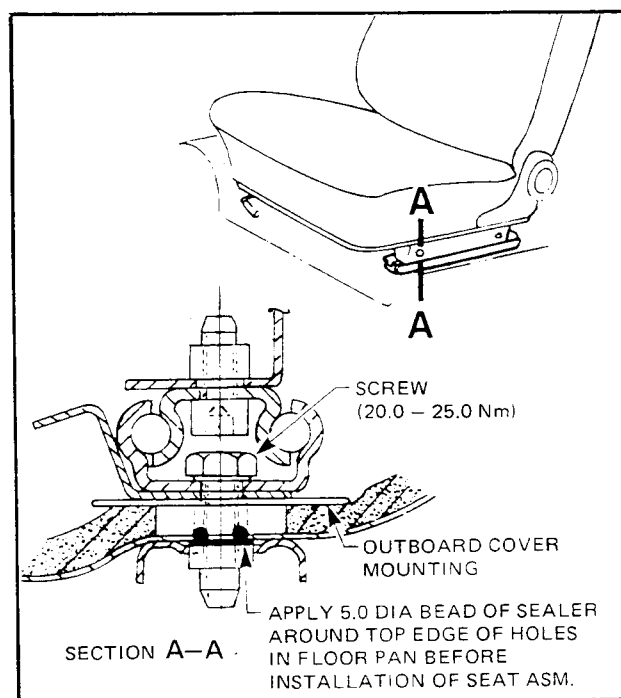

Figure 1A-38

1A-32 BODY

4. From under driver's seat cushion, remove elastic straps which are looped under tension over seat cushion spring convolutions and which retain lower edge of seat back carpet assembly (refer Fig. 1A-39) and tape carpet up out of the way.

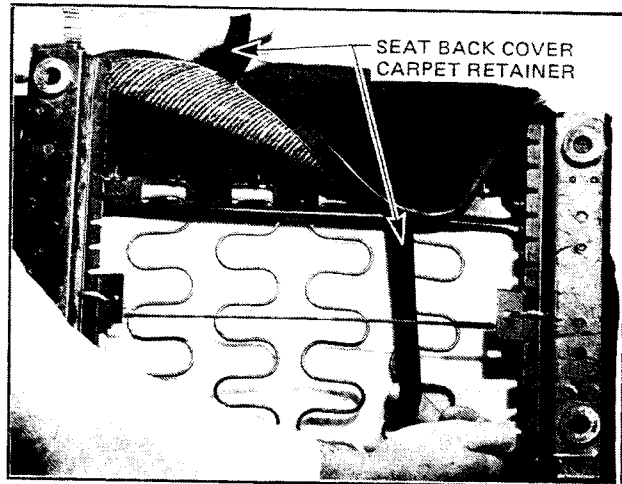

Figure 1A-39

5. Remove hog rings securing seat back cover rear retainer to front retainer (refer Fig. 1A-40).

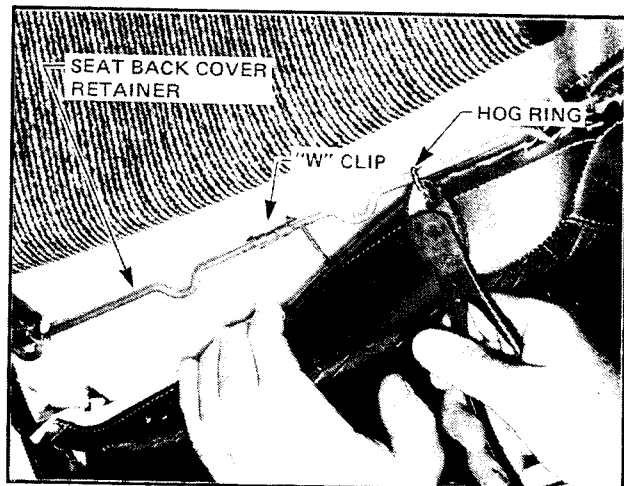

Figure 1A-40

6. Locate the forked end of a door interior handle clip removal tool (refer Fig. 1A-41) inside of lumbar support handle, then press tool downwards to disengage 'horse shoe' type retaining clip from slot in splined spindle, then remove handle.

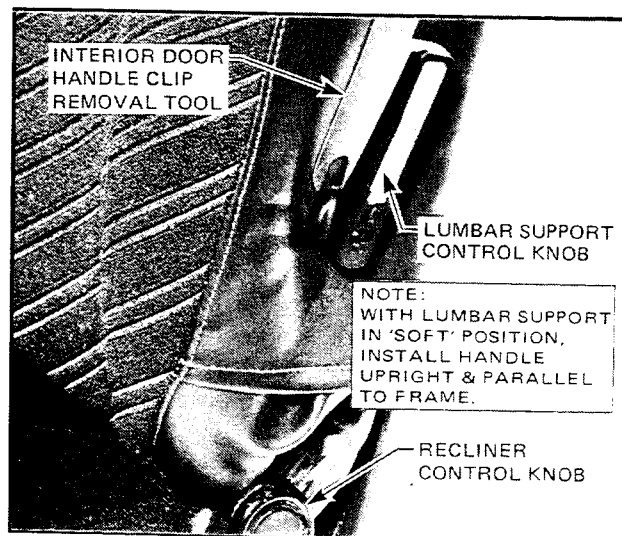

Figure 1A-41

7. Carefully ease sides of seat back cover upwards, exposing heads of screws securing lumbar support brackets to sides of seat frame (refer Fig. 1A-42).

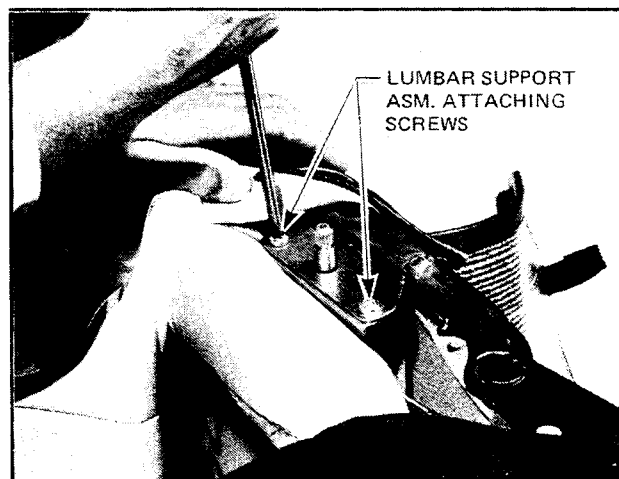

Figure 1A-42

8. Remove attaching screws, then lumbar support assembly out through bottom of seat back assembly (refer Fig. 1A-43).

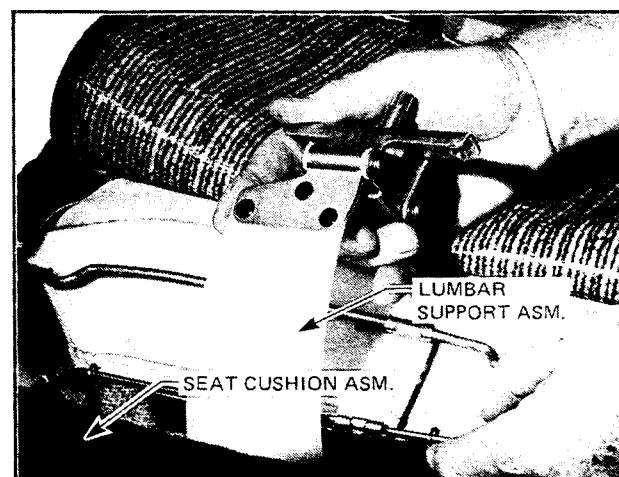

Figure 1A-43

Reinstall

Reverse removal operations, ensuring to adequately seal seat assembly attaching screw threads (refer Section A-A, Fig. 1A-38) and to observe lumbar support control knob note in Fig. 1A-41.

6.3 FRONT SEAT BELT RETRACTOR AND BUCKLE ASSEMBLIES

REMOVE

1. With front seat located fully forward, remove cover from bolt securing upper seat belt attachment to centre pillar (refer Section A-A, Fig. 1A-44) then remove bolt and upper attachment.
2. Using a pointed tool, carefully prise out the pins securing the seat belt retractor cover to the centre pillar (refer Section C-C, Fig. 1A-44).
3. Remove cover from bolt securing seat belt lower attachment to floor pan, then remove bolt and lower seat belt attachment.
4. Ease front end of rear rocker panel cover and rear end of front rocker panel cover upwards to release lower part of retractor cover, ease upper fastener from centre pillar, releasing cover and seat belt retractor (refer Fig. 1A-44).

1A-34 BODY

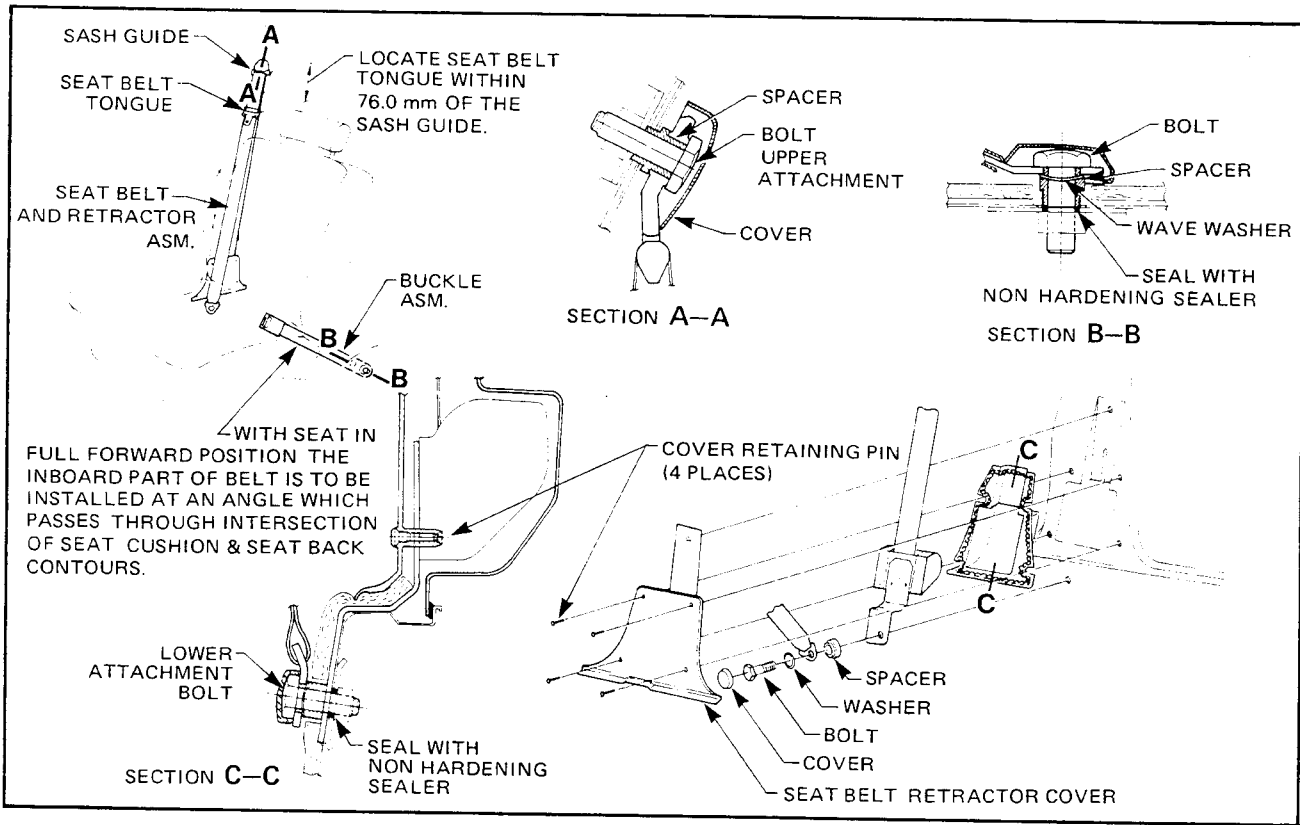

Figure 1A-44

5. Remove cover and bolt securing seat belt buckle assembly to transmission tunnel (refer Section B-B, Fig. 1A-44) then remove buckle assembly.

REINSTALL

Reverse removal operations, ensuring that both lower bolt threads are sealed with non hardening sealer and that all seat belt attaching bolts are torqued to 53 - 71 Nm.

6.4 REAR SEAT BELT RETRACTOR ASSEMBLY

Remove

1. Depress top of seat back adjacent to head restraint sleeve to gain access to clip, retaining sleeve (refer Section A-A, Fig. 1A-45). Using a flat bladed screwdriver, carefully disengage sleeve clips then lift out head restraints.
2. Twist head restraint sleeves in an anti-clockwise direction then lift sleeves out of brackets welded to the rear parcel shelf (refer Section A-A, Fig. 1A-45).

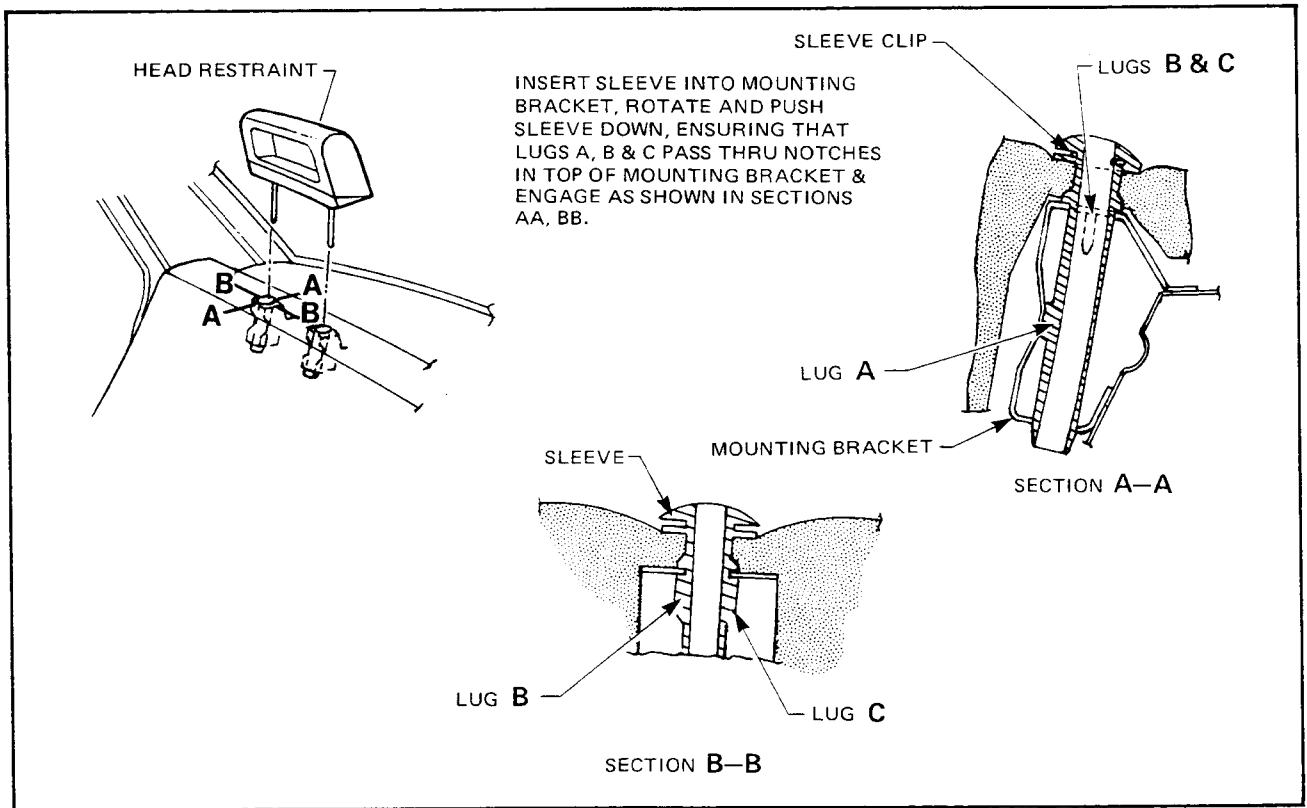

Figure 1A-45

3. Depress front edge of seat cushion assembly rearwards to disengage assembly retainer from brackets attached to the floor (refer Section A-A, Fig. 1A-46) remove, then place assembly on a clean protected surface.
4. Unclinch tabs securing seat back frame to rear wheelhouses (refer View A, Fig. 1A-46) lift frame from retaining brackets attached to the rear compartment front panel (refer Section B-B, Fig. 1A-46) remove, then place frame assembly on a clean protected surface.

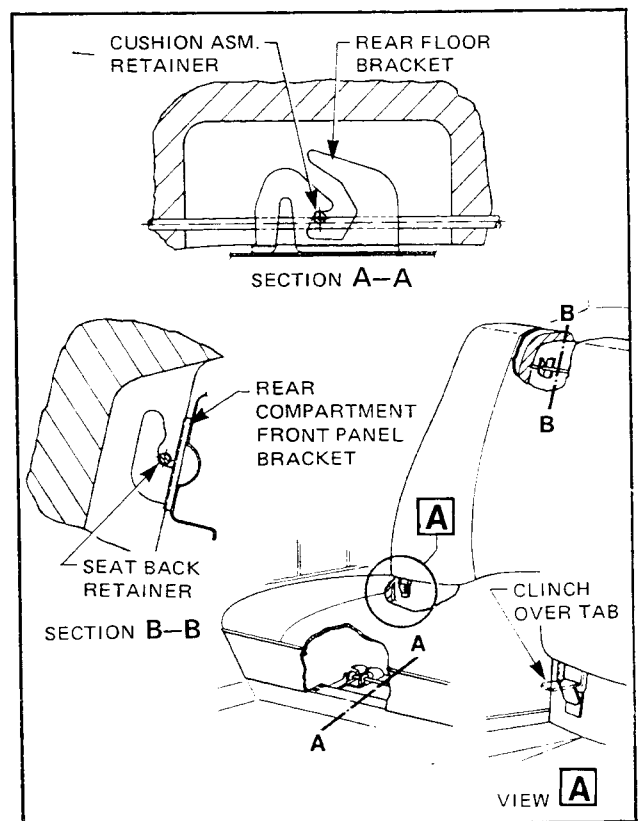

Figure 1A-46

1A-36 BODY

5. From inside rear compartment, tap out fasteners securing trim panel to rear parcel shelf (refer Section A-A, Fig. 1A-47) disconnect retractor seat belt guides from outer edges of rear parcel shelf (refer Section A-A, Fig. 1A-48) partly raise rear parcel shelf trim, disconnect speaker connectors from rear harness, then remove rear parcel shelf trim.
6. Remove bolts securing rear seat belt lower attachments, including lap type seat belts, to floor pan and rear wheelhouse panels (refer Section C-C and D-D, Fig. 1A-48).
7. Remove cover, then bolt securing rear seat belt upper attachment to quarter inner upper panel (refer Section B-B, Fig. 1A-48).
8. From inside of rear compartment, remove bolt securing rear seat belt retractor assembly to quarter inner panel (refer Section A-A, Fig. 1A-48) remove retractor assembly, feeding seat belt, buckles, etc. out through slot on outer edge of rear parcel shelf.

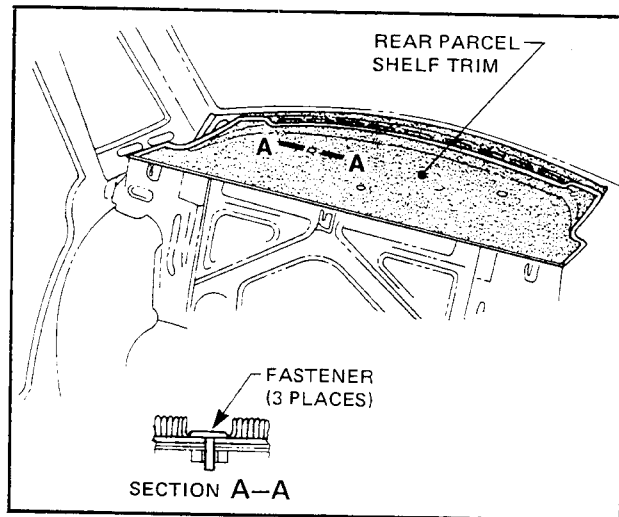

Figure 1A-47

Reinstall

Reverse removal operations, ensuring that the threads of all seat belt lower attaching bolts are adequately sealed with a non hardening sealer (refer Sections C-C and D-D, Fig. 1A-48) and that all rear seat belt attaching bolts are torqued to 50-70 Nm during installation.

NOTE: On 35 body styles, the retractor assemblies are mounted onto the rear quarter inner panels (refer Section A-A, Fig. 1A-49).

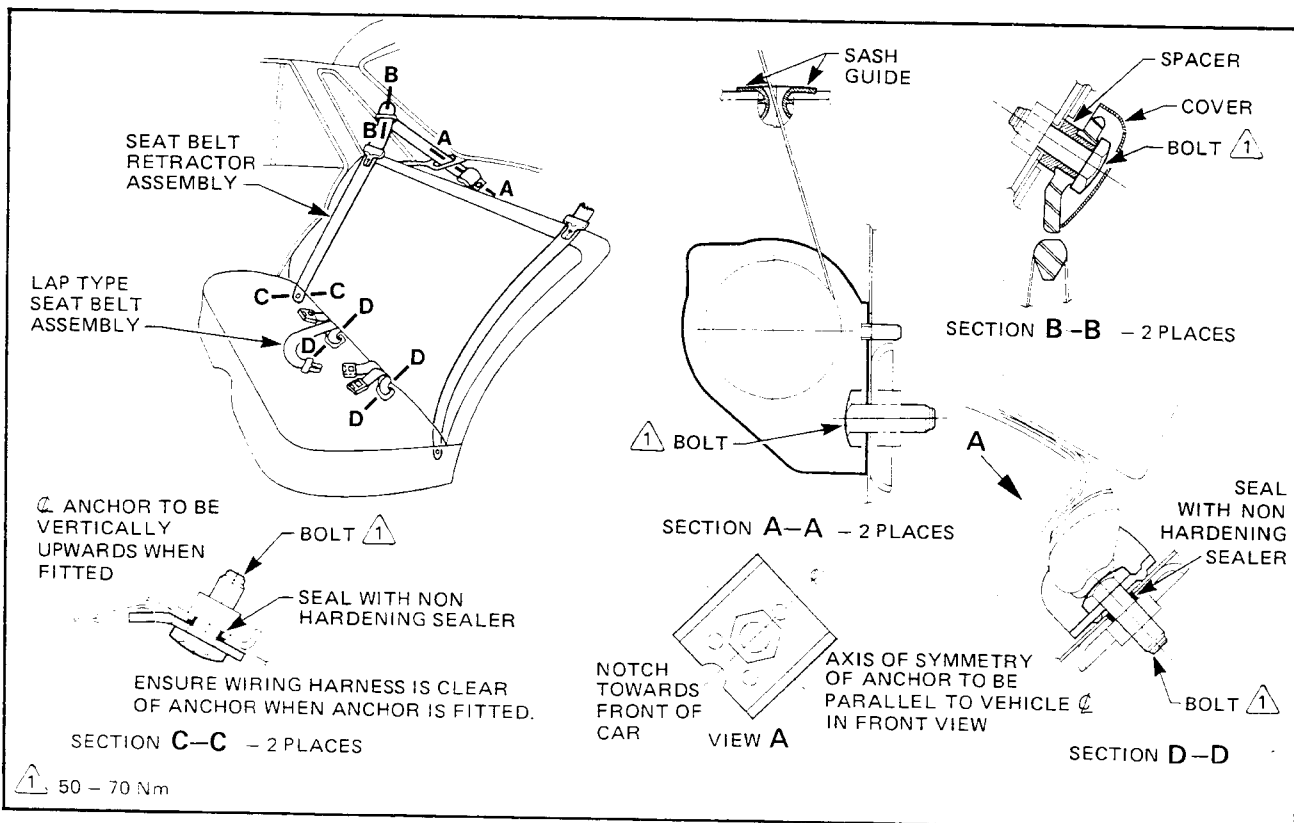

Figure 1A-48

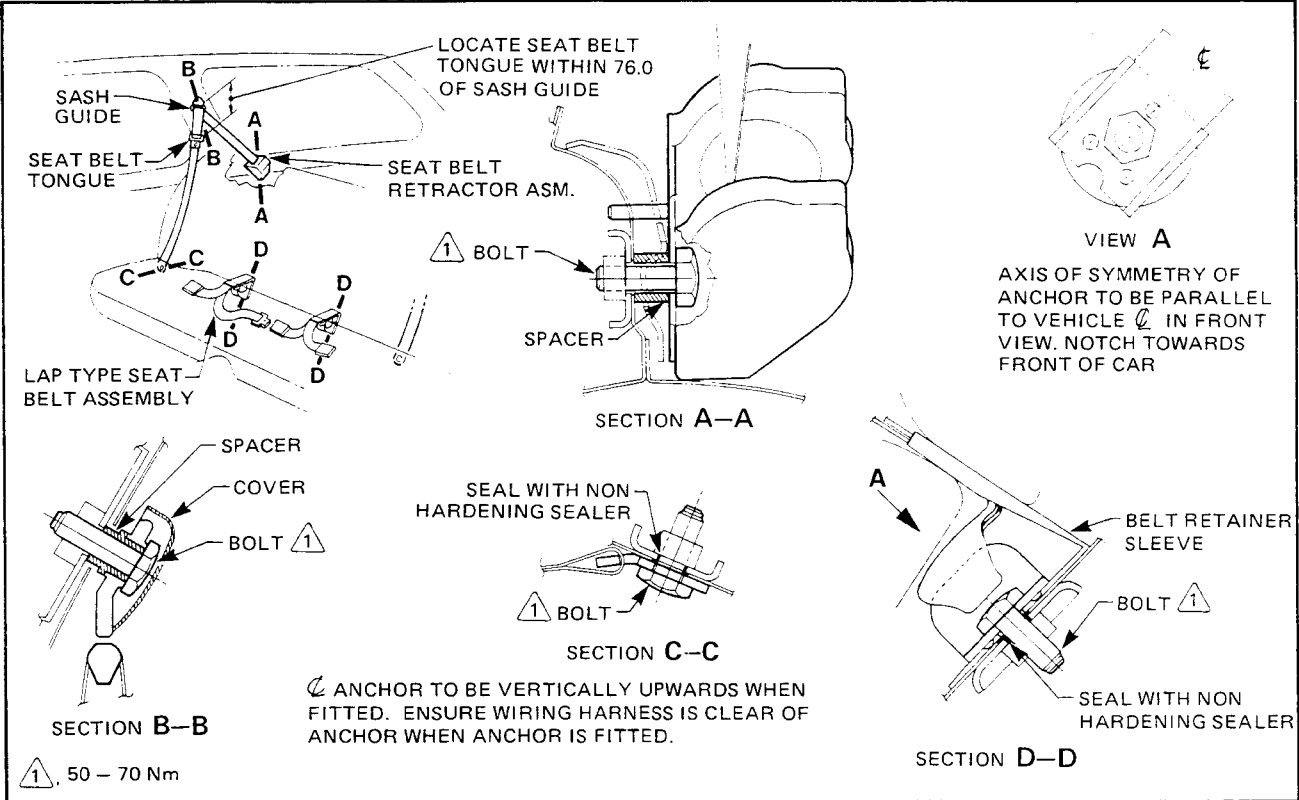

Figure 1A-49

7. EXTERIOR ORNAMENTATION

INDEX

Ref.	Subject	Page	Ref.	Subject	Page
7.1	DESCRIPTION	1A-39	7.7	TAIL LAMP REVEAL MOULDING ASSEMBLY	1A-48
7.2	FRONT PILLAR DRIP MOULDING	1A-46		Models - SL and Berlina, 19 Body Styles	1A-48
	Remove	1A-46		Remove	1A-48
	Reinstall	1A-46		Reinstall	1A-48
7.3	DRIP MOULDING ASSEMBLY REAR	1A-46		Model - Calais	1A-48
	Models - 19 Body Styles	1A-46		Remove	1A-48
	Remove	1A-46		Reinstall	1A-48
	Reinstall	1A-46	7.8	REAR LAMP EXTENSION MOULDING ASSEMBLY	1A-49
7.4	ROOF DRIP MOULDING	1A-47		Models - 19 Body Styles	1A-49
	Remove	1A-47		Remove	1A-49
	Reinstall	1A-47		Reinstall	1A-49
7.5	FRONT & REAR DOOR SIDE MOULDING ASSEMBLIES	1A-47	7.9	MOULDING ASSEMBLY - REAR COMPARTMENT LID	1A-50
	Model - Calais	1A-47		Model - Calais	1A-50
	Remove	1A-47		Remove	1A-50
	Reinstall	1A-47		Reinstall	1A-50
7.6	FRONT FENDER SIDE & SIDE PANEL FRONT MOULDING ASSEMBLIES	1A-48	7.10	EMBLEM ASSEMBLY HOOD	1A-50
	Model - Calais	1A-48		Model - Calais	1A-50
	Remove	1A-48		Remove	1A-50
	Reinstall	1A-48		Reinstall	1A-50

7.1 DESCRIPTION

Exterior ornamentation on the VK series consists of deep section body side mouldings on Calais and wide section body side mouldings on SL and Berlina 19 and 35 body styles. The Commodore/Berlina name appears on the rear of 19 and 35 body styles except on Calais, which features a Calais badge on the rear compartment lid and front fenders. Calais emblems are also fitted to the front fender and engine hood. Holden and Lion badges are fitted to the front and rear of all models except the front of the Calais, which features a Holden badge on its radiator grille. Badges for option engines and for electronic injection are fitted to the front fenders of sedans except on the Calais, which features these badges on the rear compartment lid. On models fitted

with the base engine (E.S.T.) automatic transmission together with power steering, an 'Executive' applique is applied to the quarter windows on sedans and rear door stationary windows on station wagons. Belt line mouldings are fitted to all models (refer Figs. 1A-50, 1A-51, 1A-52, 1A-53, 1A-54, 1A-55).

Clips, fastener studs, bushes, screws and contact adhesive secure the various exterior mouldings, badges, emblems, etc. to the VK body styles.

The tailgate window exterior mouldings are embedded in the urethane securing the window in the tailgate aperture. Replacement procedures for these mouldings are included in the Stationary Glass Section of this Supplement.

1A-40 BODY

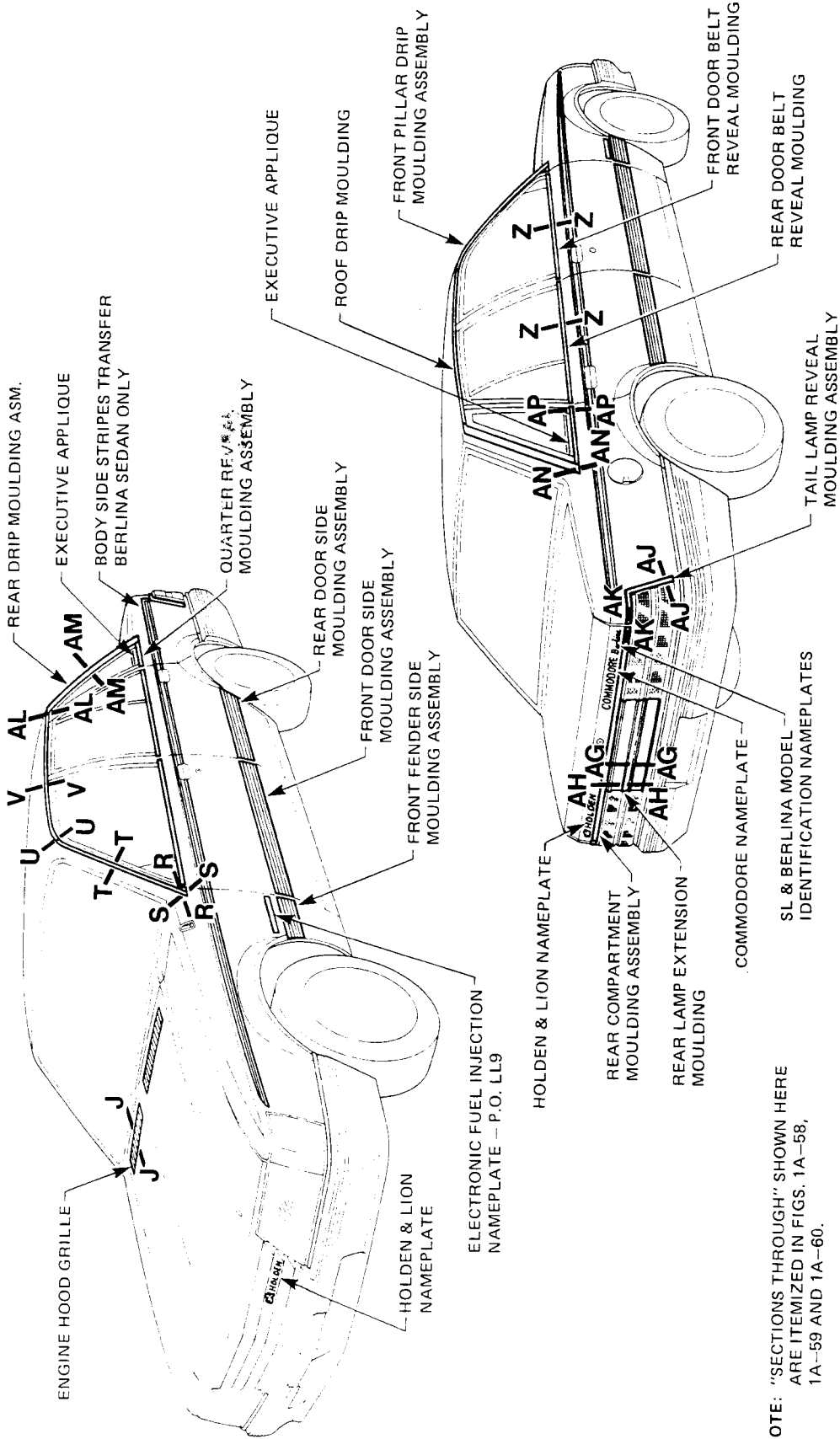

NOTE: "SECTIONS THROUGH" SHOWN HERE ARE ITEMIZED IN FIGS. 1A-58, 1A-59 AND 1A-60.

8VK/8VL19 - SL & BERLINA SEDANS

Figure 1A-50

1A-42 BODY

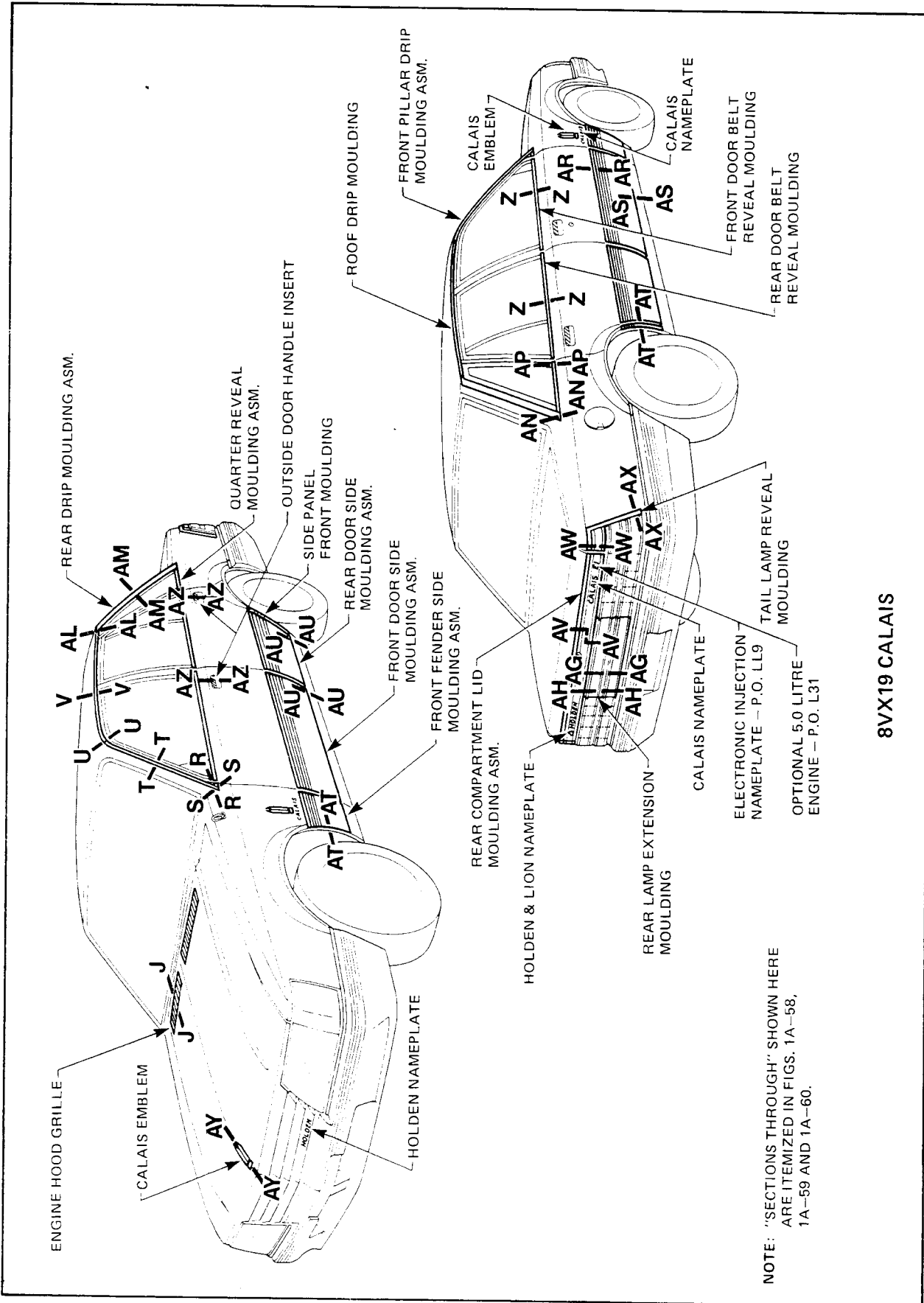

Figure 1A-52

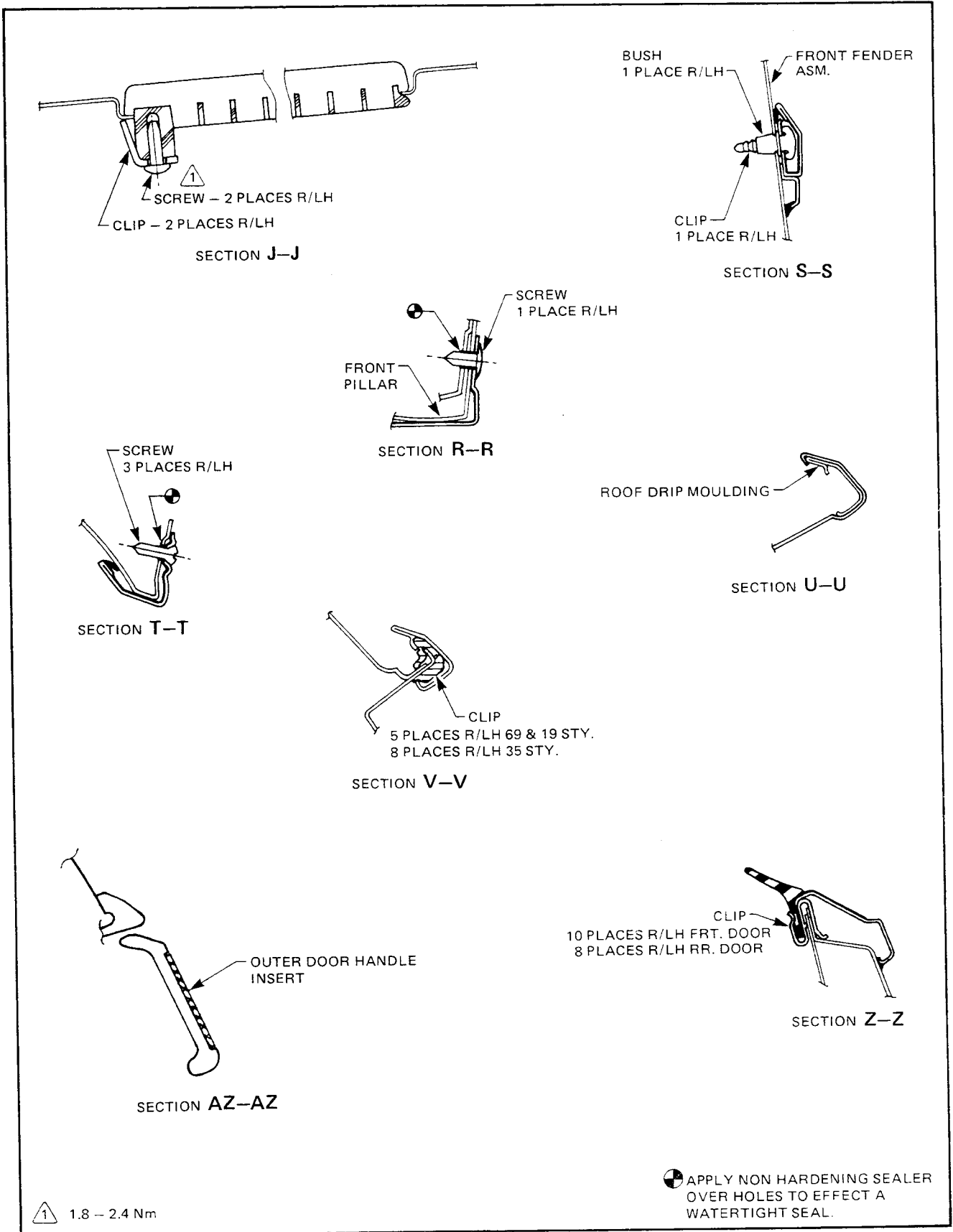

Figure 1A-53

1A-44 BODY

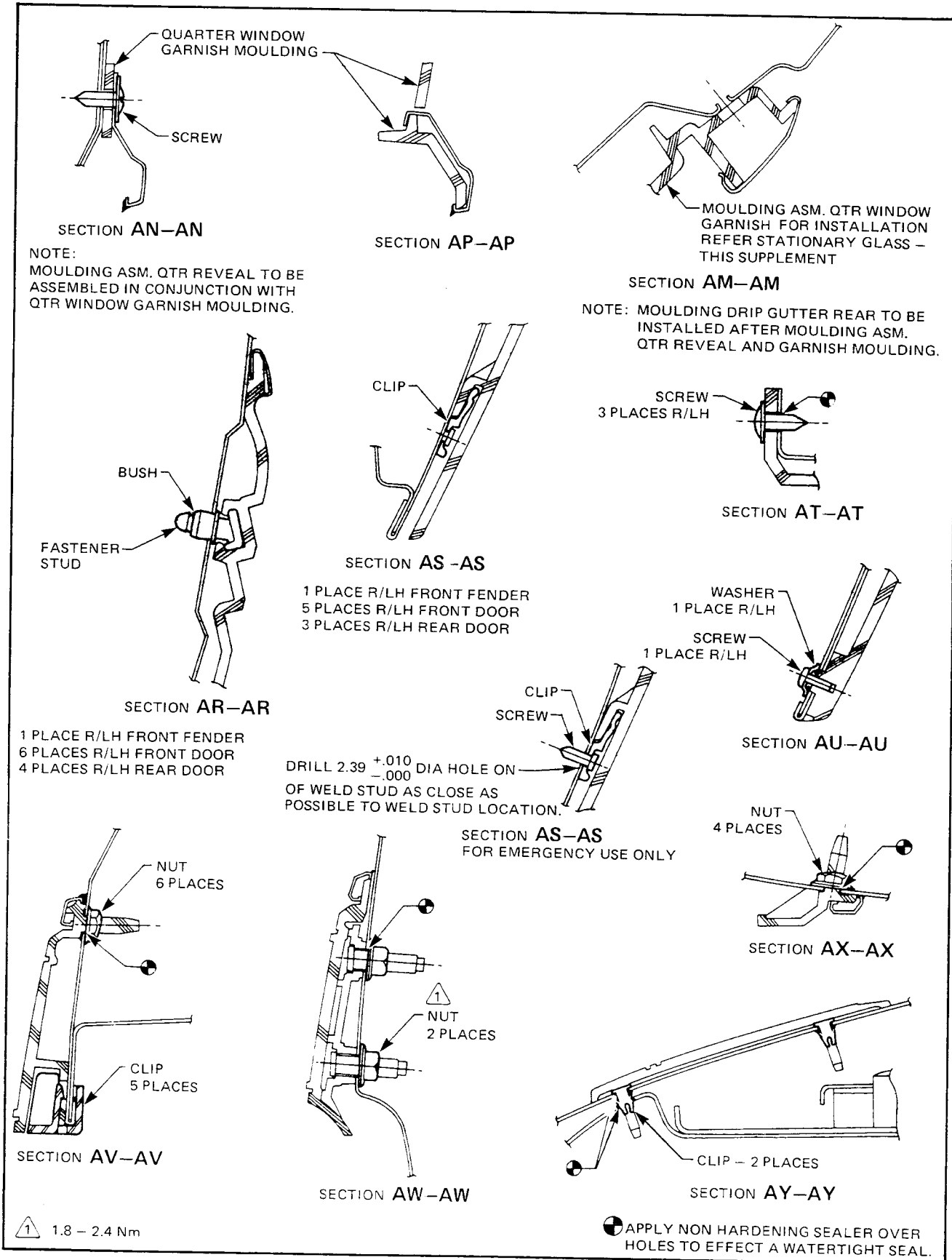

Figure 1A-54

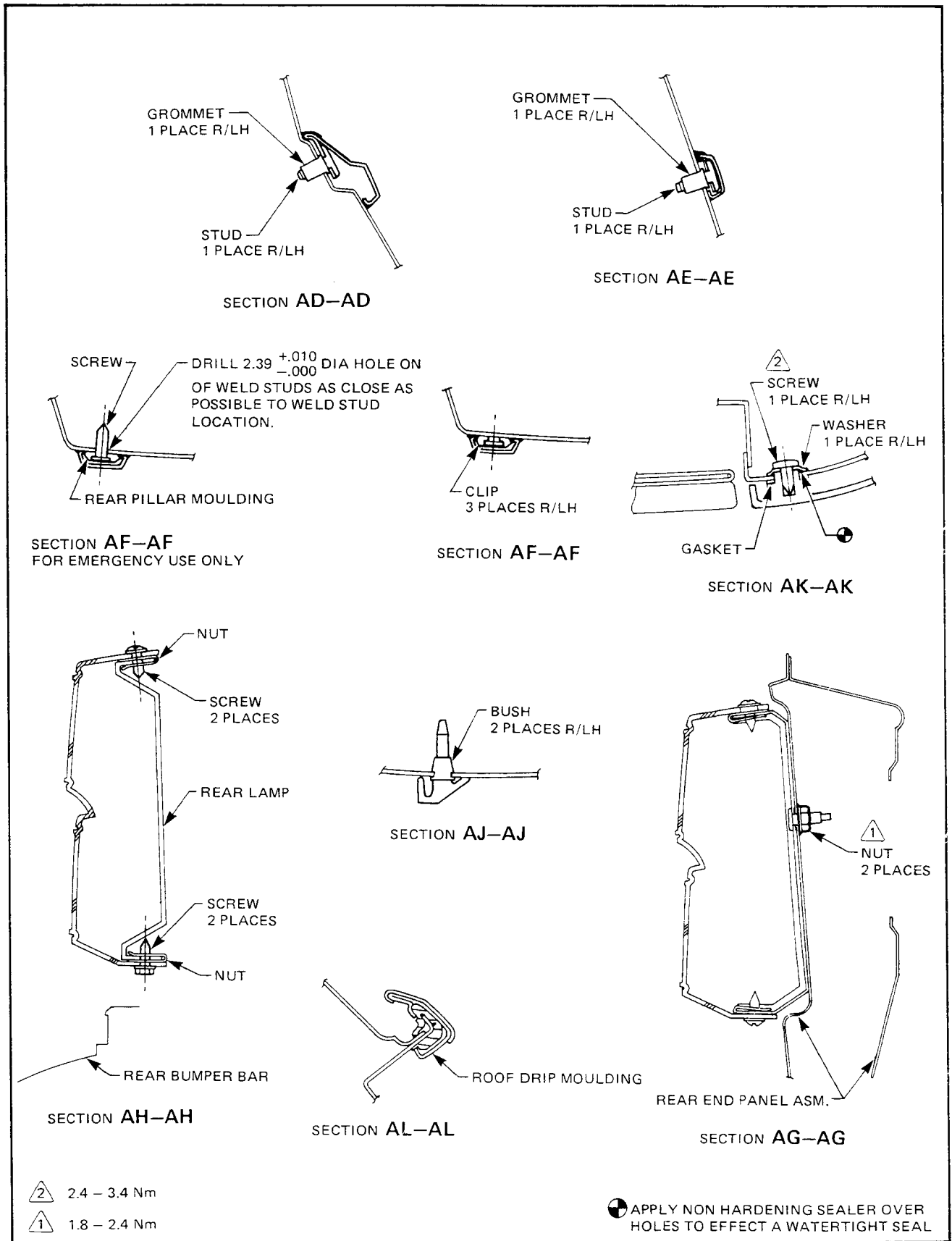

Figure 1A-55

1A-46 BODY

7.2 FRONT PILLAR DRIP MOULDING

Remove

With front door open, remove the screw and clip securing moulding to front body pillar and front fender (refer Sections S-S, T-T, and V-V, Fig. 1A-56) removing moulding.

Reinstall

Reverse removal operations ensuring that the front pillar moulding is correctly installed over the front of the roof drip moulding as illustrated in Section U-U, Fig. 1A-56 and that the screw securing the centre of the moulding to the front body pillar is adequately sealed with non hardening sealer.

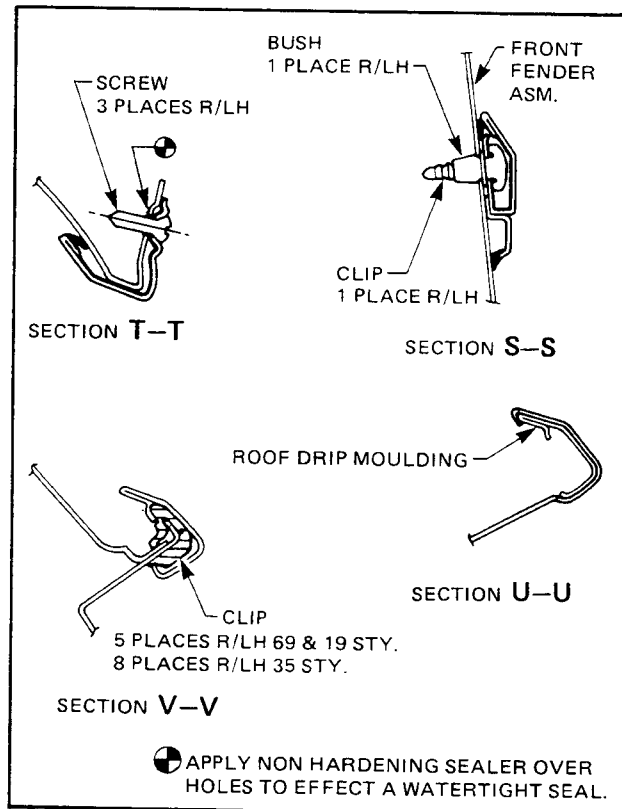

Figure 1A-56

7.3 DRIP MOULDING ASSEMBLY REAR MODELS - 19 BODY STYLES

Remove

Grasp the leading edge of the moulding, carefully pulling it off the rear quarter window garnish moulding, allowing the trailing end of the drip moulding rear to become disengaged (refer Section AM-AM, Fig. 1A-57).

Reinstall

Locate the rear hooked edge of the moulding over the rear quarter window garnish moulding, then lightly tap the moulding into position, ensuring that the rear drip moulding is correctly installed over the rear of the roof drip moulding as illustrated in Section U-U, Fig. 1A-56.

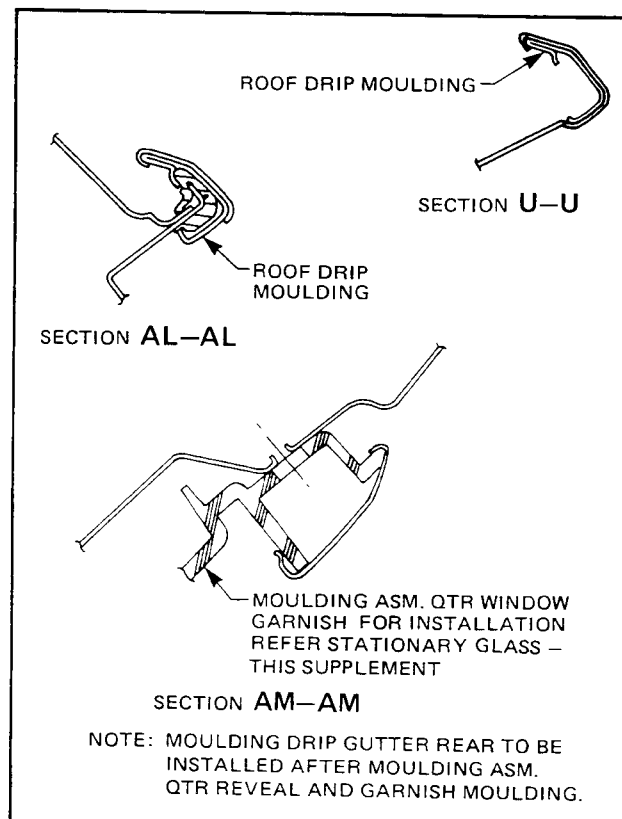

Figure 1A-57

7.4 ROOF DRIP MOULDING

Remove

1. With the front door open, remove the screw securing the top of the drip moulding to the front body pillar (refer Section T-T, Fig. 1A-56).
2. Using Tool No. 1A7 located as illustrated in Fig. 1A-58, under top of front pillar drip moulding, carefully ease top of pillar moulding off front end of roof drip moulding (refer Section U-U, Fig. 1A-56).
3. Using a similar procedure with Tool No. 1A7, remove the roof drip moulding, carefully disengaging rear end of roof drip moulding from top of drip moulding assembly rear (refer Section U-U, Fig. 1A-56).

Reinstall

Reverse removal operations ensuring that the ends of the roof drip moulding are correctly installed under the front pillar and rear assembly drip mouldings as illustrated in Sections T-T and AL-AL in Figs. 1A-56 and 1A-57 and that the screw securing the front pillar drip moulding is adequately sealed with a non hardening sealer.

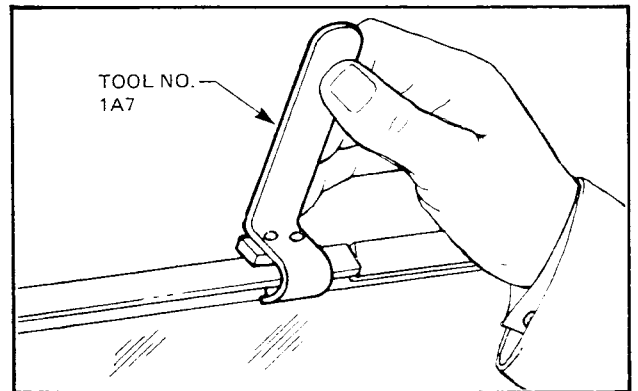

Figure 1A-58

7.5 FRONT & REAR DOOR SIDE MOULDING ASSEMBLIES

MODEL - CALAIS

Remove

1. With front or rear door open, remove screw securing rear lower section of moulding to door (refer Section AU-AU, Fig. 1A-59).
2. Apply masking tape adjacent to top of moulding to protect paint finish, then using a wide bladed screwdriver, carefully prise upper section of moulding assembly out of retaining bushes (refer Section AR-AR, Fig. 1A-59) then raise moulding off the clips securing the lower section of the moulding assembly to the door (refer Section AS-AS, Fig. 1A-59).

Reinstall

Reverse removal operations.

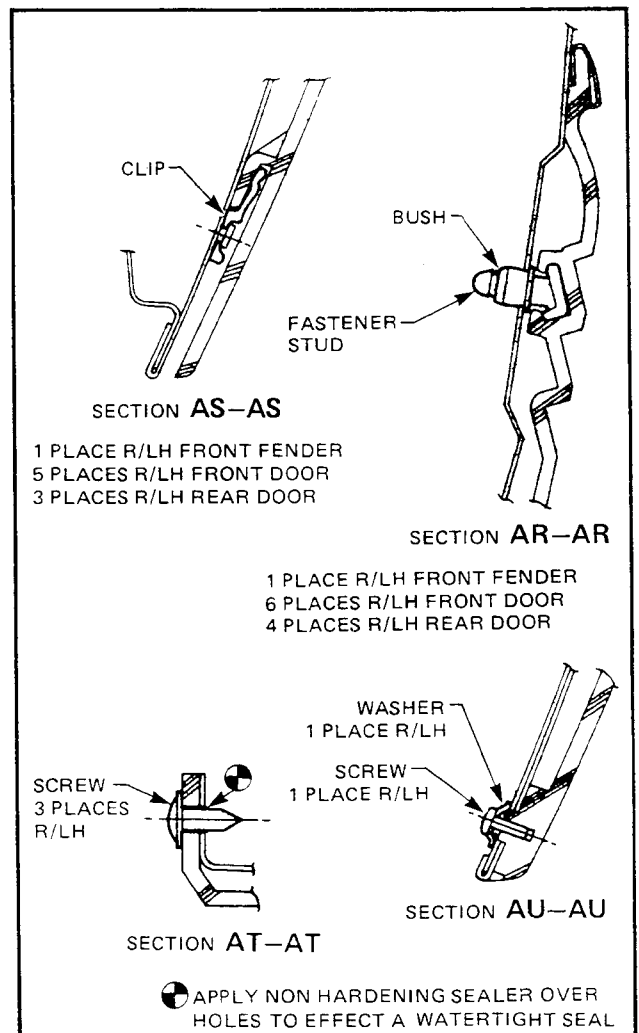

Figure 1A-59

1A-48 BODY

7.6 FRONT FENDER SIDE & SIDE PANEL FRONT MOULDING ASSEMBLIES

MODEL - CALAIS

Remove

From inside the wheelhouse, remove screw securing moulding to rear quarter or front fender panel (refer Section AT-AT, Fig. 1A-59) then remove moulding.

Reinstall

Reverse removal operations ensuring to adequately seal the attaching screw with non hardening sealer as illustrated in Section AT-AT, Fig. 1A-59.

NOTE: Rear compartment lid moulding on SL and Berlina 19 body styles and body side and tailgate mouldings on SL and Berlina 35 body styles as well as nameplates and emblems on all models are secured in position with contact adhesive. It is necessary to apply heat to these mouldings prior to removing them from the panels to avoid bending the outer surface of these mouldings.

CAUTION: Ensure that source of heat is not too close or temperature too high to damage paint finish.

When replacing these mouldings, the corresponding panel surface must be clean and smooth and be subjected to warmth prior to installation of the moulding to effect a sound bonding of the moulding to the panel.

7.7 TAIL LAMP REVEAL MOULDING ASSEMBLY

MODELS - SL AND BERLINA 19 BODY STYLES

Remove

1. With rear compartment lid open, remove the screw securing the upper section of the moulding to the rear quarter outer panel (refer Section AK-AK, Fig. 1A-60).
2. Apply masking tape adjacent to the semi vertical section of the moulding to protect paint finish, then using a wide bladed screwdriver, carefully prise lower section of moulding out of retaining bush (refer Section AJ-AJ, Fig. 1A-60).

Reinstall

Reverse removal operations ensuring to adequately seal the attaching screw with non hardening sealer as illustrated in Section AK-AK, Fig. 1A-60.

MODEL - CALAIS

Remove

With rear compartment lid open, remove the nuts securing the moulding assembly to the rear quarter outer panel (refer Sections AW-AW and AX-AX, Fig. 1A-61) removing the moulding assembly.

Reinstall

Reverse removal operations ensuring that adequate non hardening sealer is applied between the back panel and nut, as illustrated in Sections AW-AW and AX-AX, Fig. 1A-61).

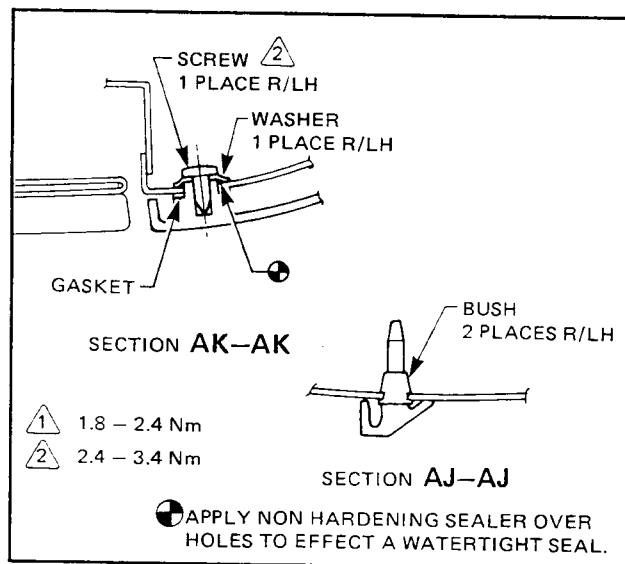

Figure 1A-60

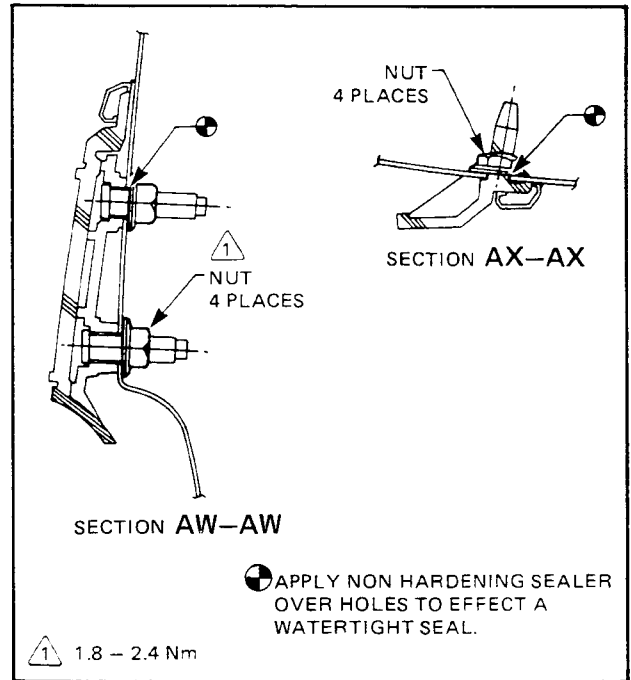

Figure 1A-61

7.8 REAR LAMP EXTENSION MOULDING ASSEMBLY

MODELS - 19 BODY STYLES

Remove

With rear compartment lid raised remove the nuts securing the assembly to the back panel upper (refer Section AG-AG, Fig. 1A-62) and remove assembly.

NOTE: To disassemble the moulding assembly, remove the screws securing the outer to inner panels of the assembly (refer Section AG-AG, Fig. 1A-62).

Reinstall

Reverse removal operations.

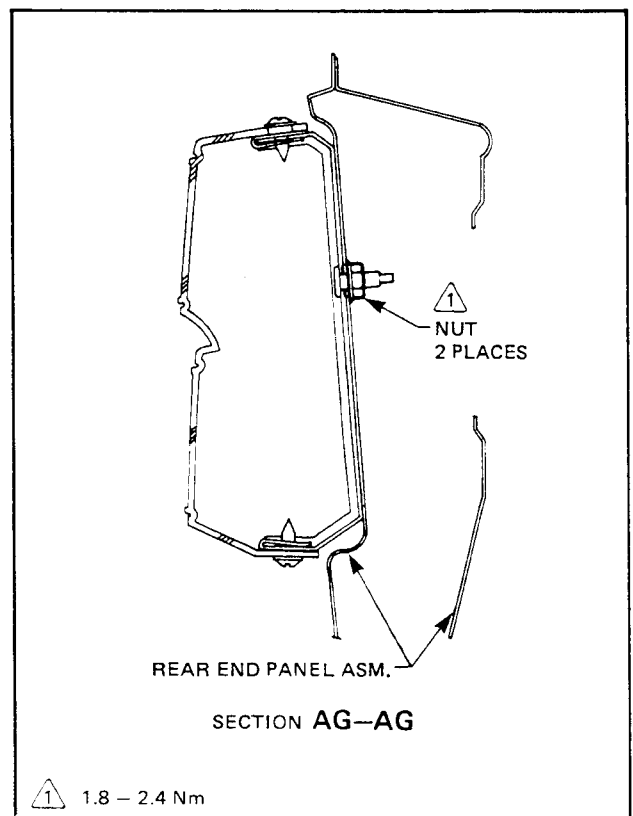

Figure 1A-62

1A-50 BODY

7.9 MOULDING ASSEMBLY REAR COMPARTMENT LID

MODEL - CALAIS

Remove

With rear compartment lid open, remove the nuts securing the moulding to the rear compartment lid (refer Section AV-AV, Fig. 1A-63) then remove the moulding.

Reinstall

Reverse removal operations ensuring that adequate sealing with non hardening sealer is applied between the inside of the attaching nuts and rear compartment lid as illustrated in Section AV-AV, Fig. 1A-63.

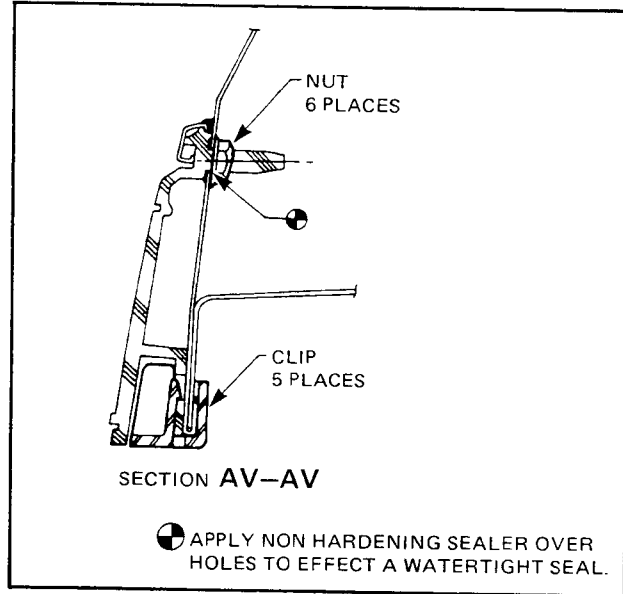

Figure 1A-63

7.10 EMBLEM ASSEMBLY HOOD

MODEL - CALAIS

Remove

With engine hood raised and using a plastic mallet, lightly tap ends of emblem studs protruding through tubular retaining clips in the engine hood (refer Section AY-AY, Fig. 1A-64) until it is possible to remove emblem.

Reinstall

Reverse removal operations ensuring that the tubular clips fully retain the emblem.

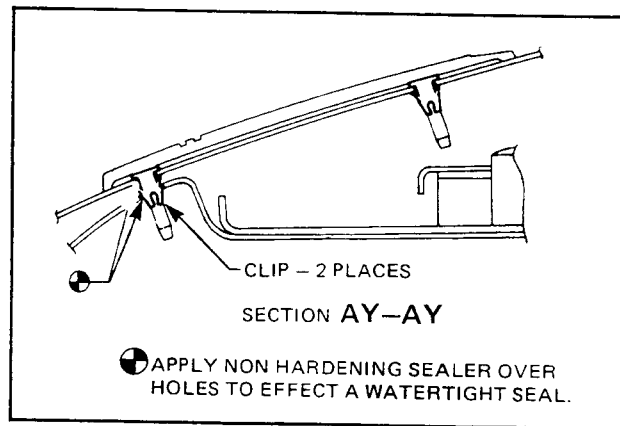

Figure 1A-64

8. ROOF RACK

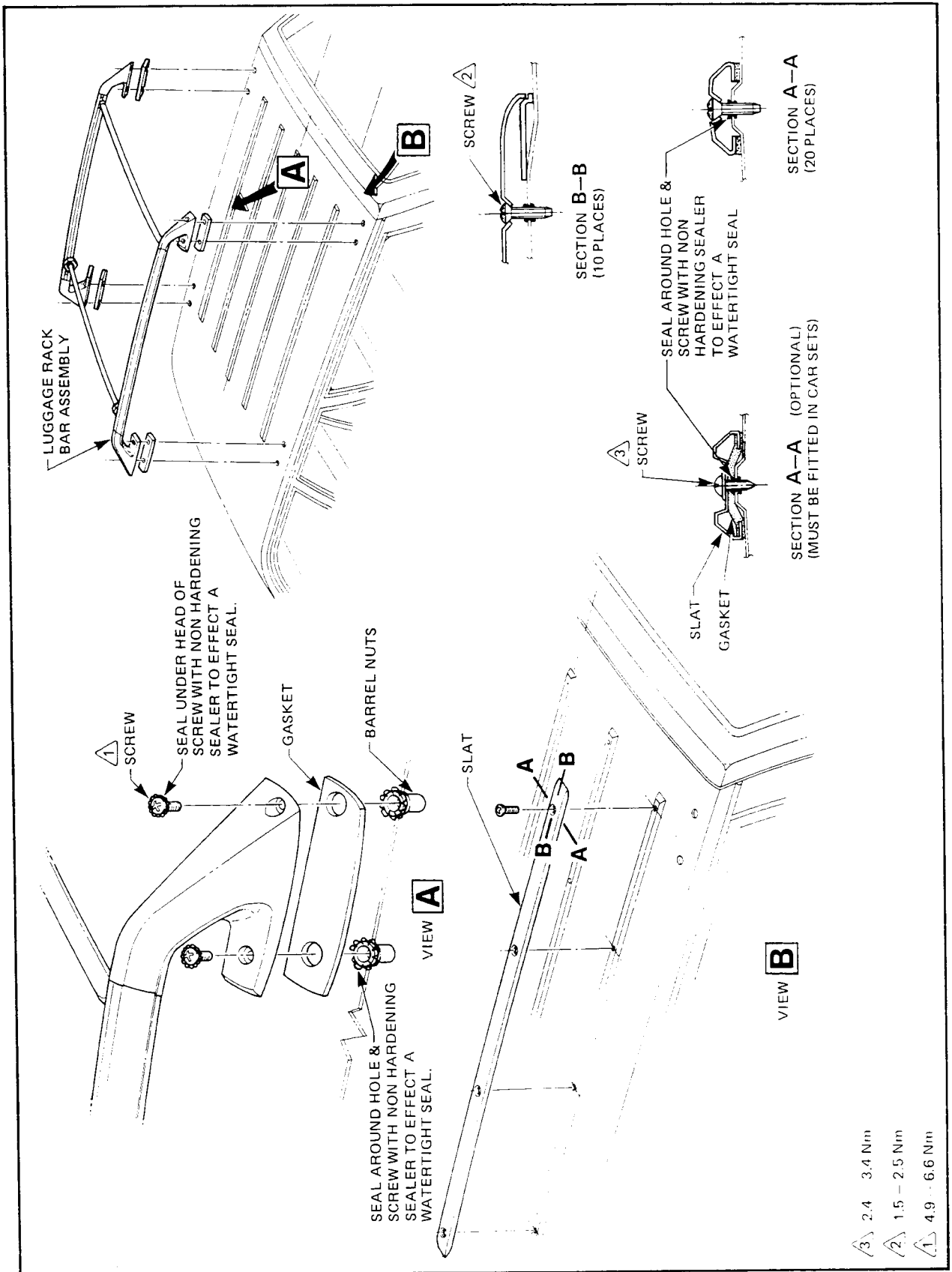

Figure 1A-65

9. BODY ELECTRICAL

INDEX

Ref.	Subject	Page	Ref.	Subject	Page
9.1	DESCRIPTION	1A-53	9.6	LIMIT SWITCH ASSEMBLY	1A-61
9.2	EXTERIOR REAR VIEW MIRROR & MOTOR ASSEMBLY.....	1A-54		Remove.....	1A-61
	Remove.....	1A-54		Reinstall	1A-61
	Reinstall	1A-54	9.7	ELECTRONIC MODULE ASSEMBLY	1A-62
9.3	SWITCH ASSEMBLY - EXTERIOR REAR VIEW MIRRORS	1A-55		Remove.....	1A-62
	Remove.....	1A-55		Reinstall	1A-62
	Reinstall	1A-55	9.8	CABLE ASSEMBLY	1A-62
9.4	SUNROOF SLIDING GLASS PANEL	1A-55		Remove.....	1A-62
	Remove.....	1A-55		Reinstall	1A-64
	Reinstall	1A-55	9.9	SLIDING SUNROOF MOTOR ASSEMBLY..	1A-65
	Vertical Adjustment of Sliding Panel	1A-59		Motor Assembly Removal	1A-65
9.5	WIND DEFLECTOR FRAME	1A-60		Motor Assembly Reinstallation.....	1A-65
	Remove.....	1A-60		Motor Drive Gear Removal	1A-65
	Reinstall	1A-60		Motor Drive Gear Reinstallation.....	1A-65
			9.10	SYSTEM TIMING.....	1A-66

9.1 DESCRIPTION

The electrically operated exterior rear view mirror assembly fitted to Calais models consists of a mirror with its electric drive motor contained in the door mounted mirror housing assembly (refer Fig. 1A-66).

The electric motor, which is activated by a switch mounted onto the transmission console (refer View A, Fig. 1A-67) provides complete adjustment of the mirrors.

An 'In-line' one amp fuse and holder assembly is attached to the mirror switch electrical harness and is

located under the transmission console (refer View A, Fig. 1A-67).

Choice of the mirror to be adjusted involves pushing the raised bar of the switch to the left or right. Depressing the four way directional arrows illustrated on the upper face of the switch will provide the desired mirror adjustment.

Electrically operated venting sun roofs are released as Production Option CF5 for 19 body styles except 'SL' models.

1A-54 BODY

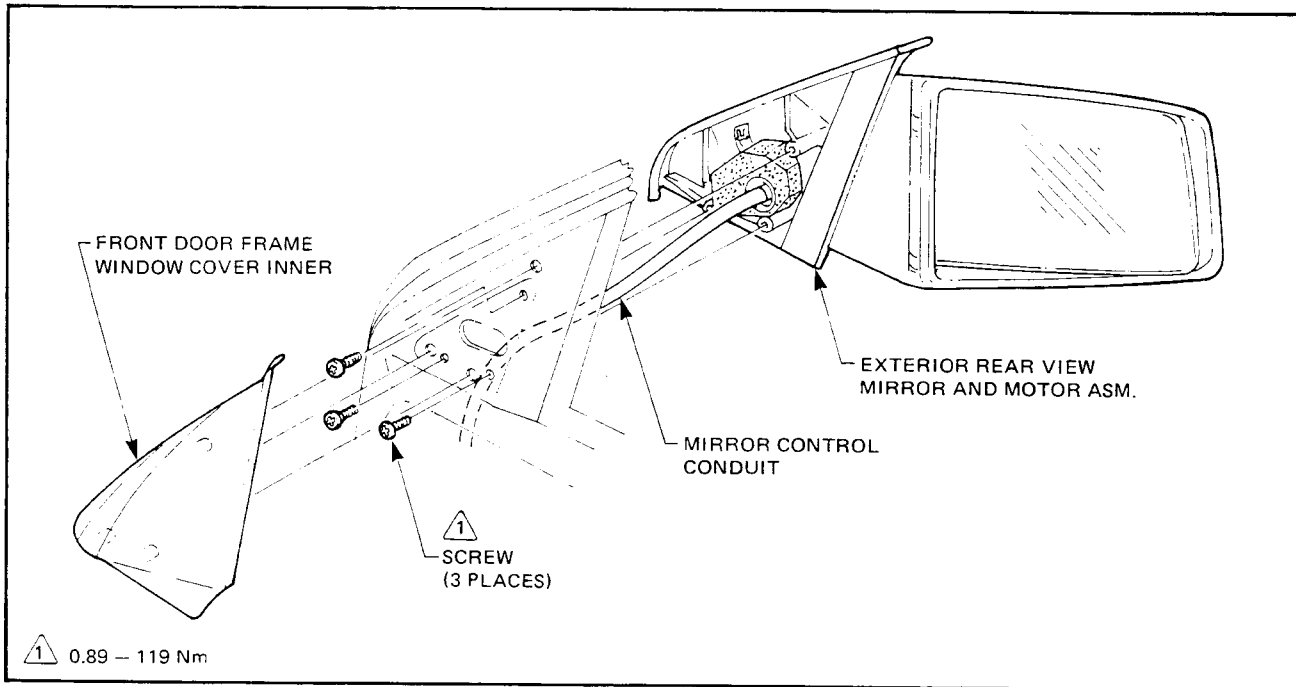

Figure 1A-66

9.2 EXTERIOR REAR VIEW MIRROR & MOTOR ASSEMBLY

REMOVE

1. With the front door window in the lowered position, disconnect the battery ground cable.
2. Remove door armrest, interior trim and upper front corner of water deflector.
3. Using a wide bladed screwdriver, carefully prise off cover from front door window frame inner, then remove seal (refer Fig. 1A-66).
4. Prise out front lower section of glass run channel from rear edge of mirror housing assembly.
5. From within door panels, disengage mirror assembly connector from door electrical harness.
6. Remove screws securing mirror assembly to door upper frame (refer Fig. 1A-66) then ease assembly rearwards and out of upper door frame.

REINSTALL

Reverse removal operations.

9.3 SWITCH ASSEMBLY - EXTERIOR REAR VIEW MIRRORS

REMOVE

1. Disconnect battery ground cable.
2. Using a wide bladed screwdriver, carefully prise cap and bezel covering top of switch assembly (refer View A, Fig. 1A-67) from transmission console.
3. Using a similar procedure, carefully prise switch assembly from transmission console. Disengage switch connector from front end electrical wiring harness, then remove the switch assembly.

REINSTALL

Reverse removal operations.

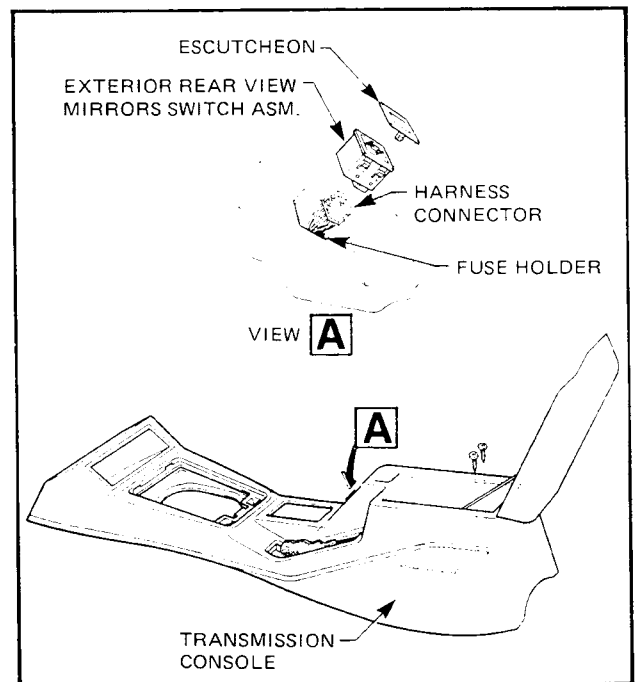

Figure 1A-67

9.4 SUNROOF SLIDING GLASS PANEL

REMOVE

1. Place sunroof sliding panel in VENT position.
2. Slide sunshade full rearward.
3. Remove side finishing covers attaching screws (Fig. 1A-70).
4. Loosen rear guides shaft screws until rear of sliding panel drops down using 3 mm allen wrench (Fig. 1A-71).
5. Remove front guide shoulder bolts using 7 mm socket (refer Fig. 1A-71).
6. Remove sliding panel upward through roof opening.

REINSTALL

Reverse removal operations.

1A-56 BODY

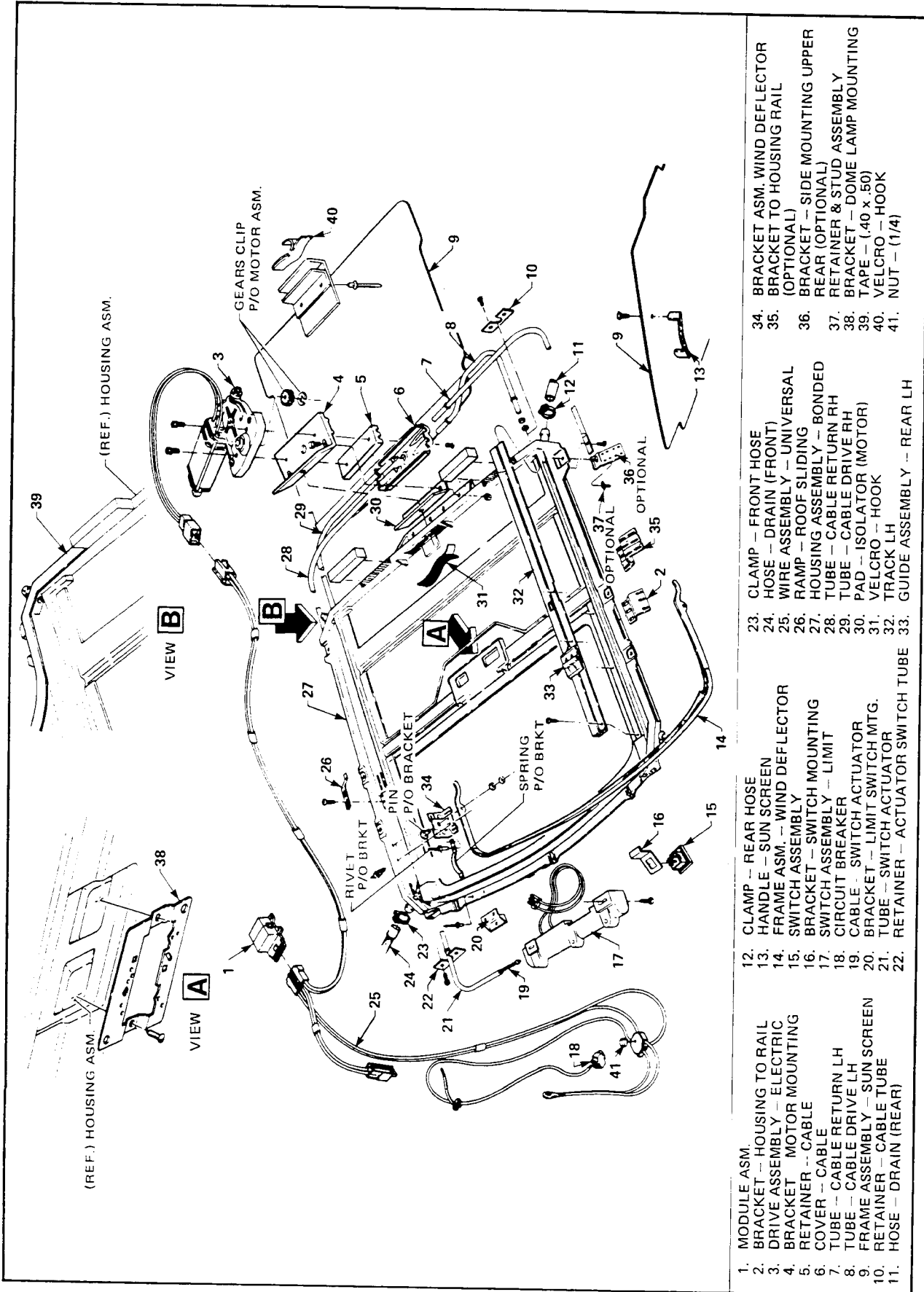

- | | | | |
|---|---|--|---|
| <p>1. MODULE ASM.
2. BRACKET -- HOUSING TO RAIL
3. DRIVE ASSEMBLY -- ELECTRIC
4. BRACKET MOTOR MOUNTING
5. RETAINER -- CABLE
6. COVER -- CABLE
7. TUBE -- CABLE RETURN LH
8. TUBE -- CABLE DRIVE LH
9. FRAME ASSEMBLY -- SUN SCREEN
10. RETAINER -- CABLE TUBE
11. HOSE -- DRAIN (REAR)</p> | <p>12. CLAMP -- REAR HOSE
13. HANDLE -- SUN SCREEN
14. FRAME ASM. -- WIND DEFLECTOR
15. SWITCH ASSEMBLY
16. BRACKET -- SWITCH MOUNTING
17. SWITCH ASSEMBLY -- LIMIT
18. CABLE -- SWITCH ACTUATOR
19. FRAME ASSEMBLY -- SUN SCREEN
20. RETAINER -- CABLE TUBE
21. TUBE -- SWITCH ACTUATOR
22. RETAINER -- ACTUATOR SWITCH TUBE</p> | <p>23. CLAMP -- FRONT HOSE
24. HOSE -- DRAIN (FRONT)
25. WIRE ASSEMBLY -- UNIVERSAL
26. RAMP -- ROOF SLIDING
27. HOUSING ASSEMBLY -- BONDED
28. TUBE -- CABLE RETURN RH
29. TUBE -- CABLE DRIVE RH
30. PAD -- ISOLATOR (MOTOR)
31. VELCRO -- HOOK
32. TRACK LH
33. GUIDE ASSEMBLY -- REAR LH</p> | <p>34. BRACKET ASM. WIND DEFLECTOR
35. BRACKET TO HOUSING RAIL (OPTIONAL)
36. BRACKET -- SIDE MOUNTING UPPER
37. REAR (OPTIONAL)
38. RETAINER & STUD ASSEMBLY
39. TAPE -- (.40 x .50)
40. VELCRO -- HOOK
41. NUT -- (1/4)</p> |
|---|---|--|---|

Figure 1A-68

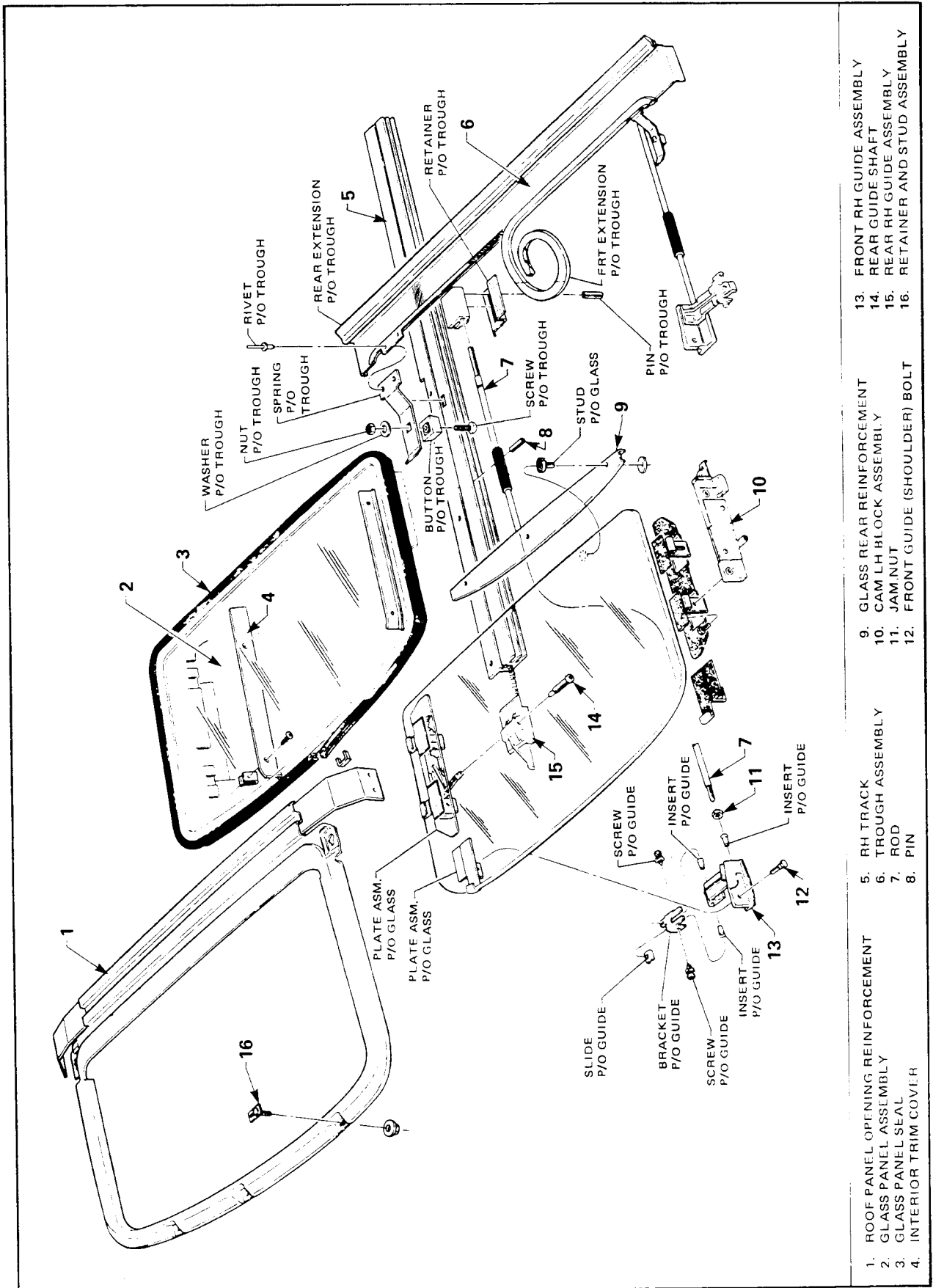

Figure 1A-69

1A-58 BODY

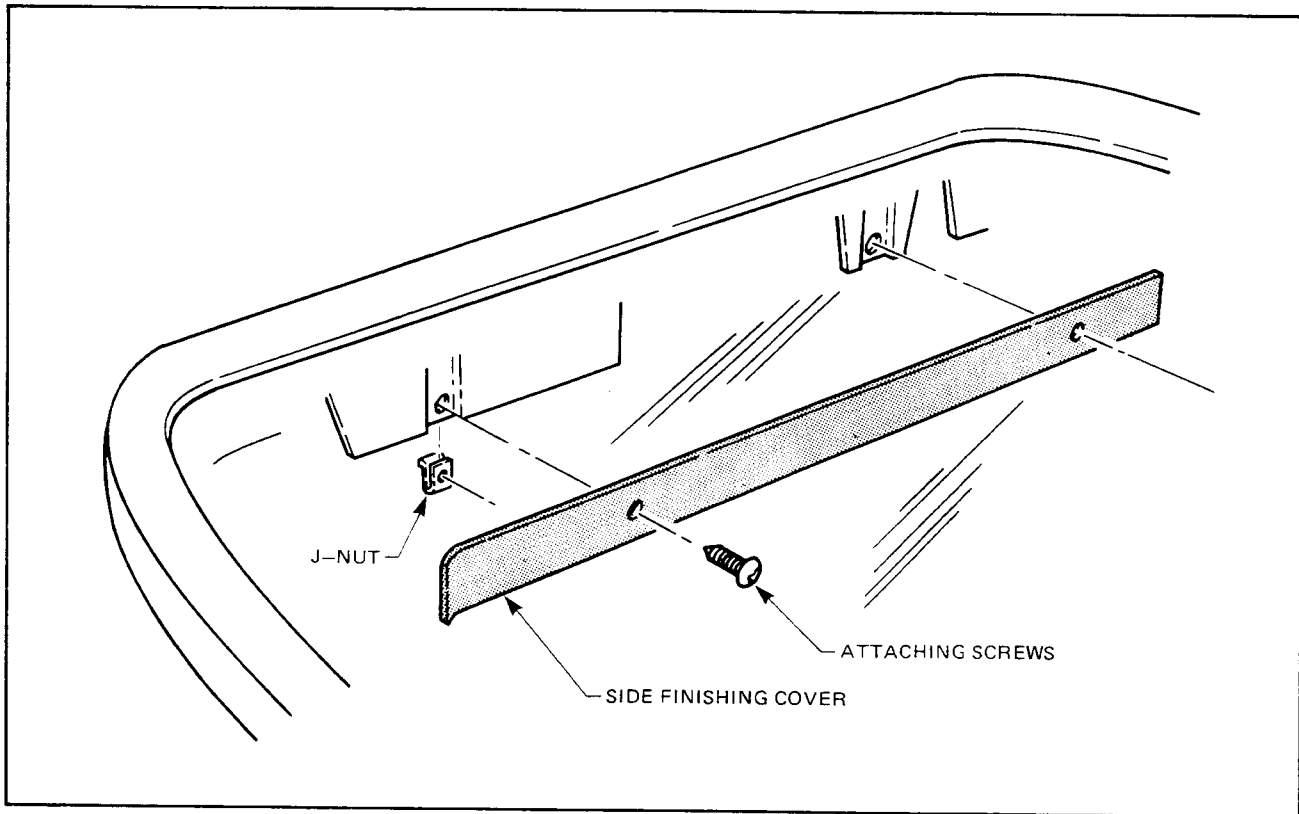

Figure 1A-70

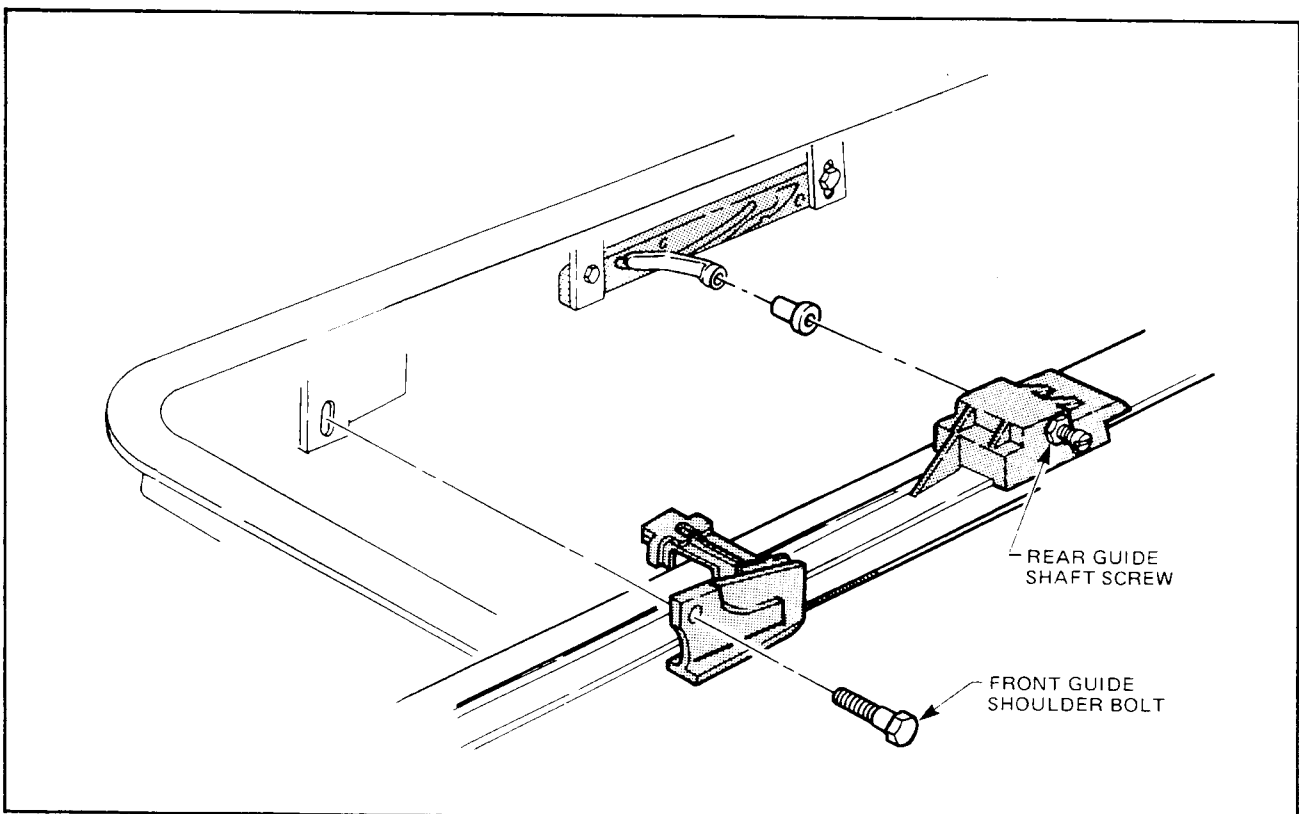

Figure 1A-71

VERTICAL ADJUSTMENT OF SLIDING PANEL

1. Activate sun roof switch assembly until rear end of glass panel is fully lowered.
2. Fully engage rear guide shaft screw illustrated in Fig. 1A-72 into cam block, then back off screw a half turn.
3. Torque shaft screw lock nut to 2.03 - 2.71 Nm.

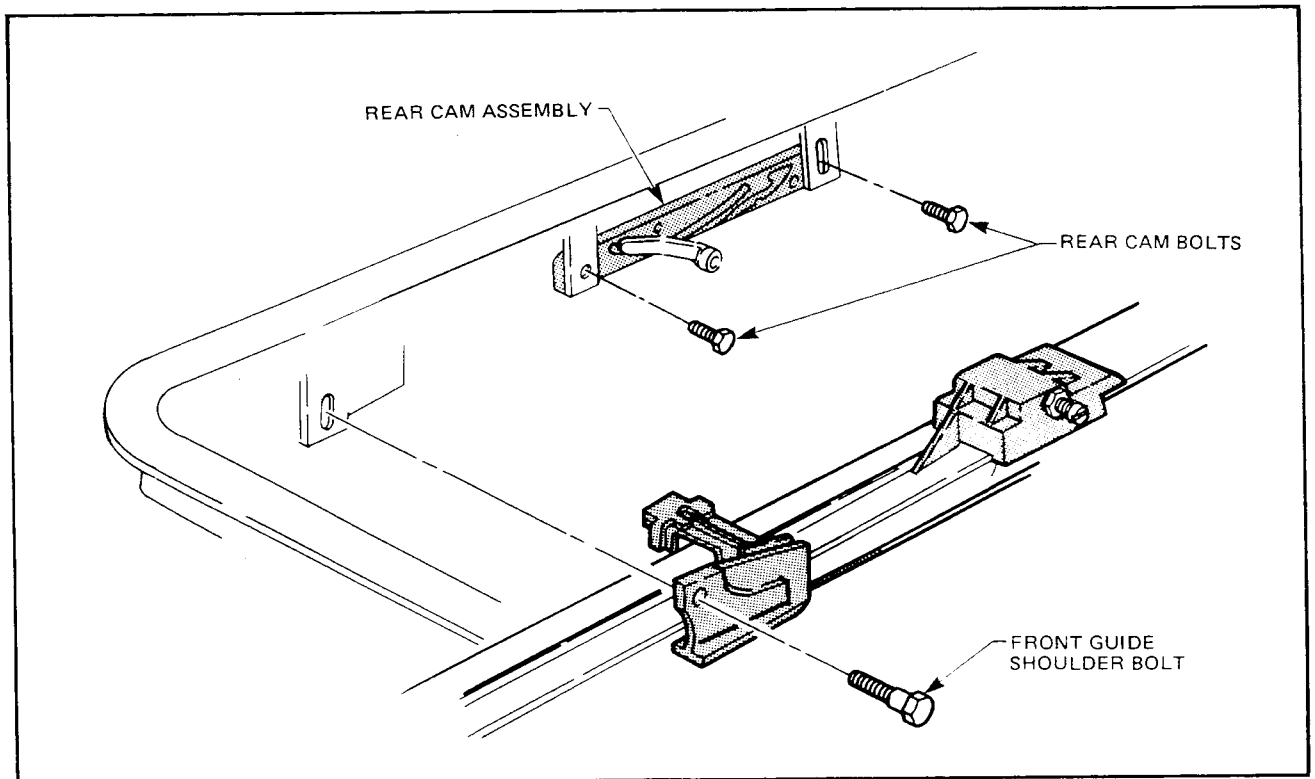

Figure 1A-72

1A-60 BODY

9.5 WIND DEFLECTOR FRAME

REMOVE

1. Place sliding panel in full rear position.
2. Remove 'C' clip retainer and flat washer from both sides (refer Fig. 1A-73).
3. Press both wind deflector frame arms inboard to remove arms from housing studs.

REINSTALL

Reverse removal operations.

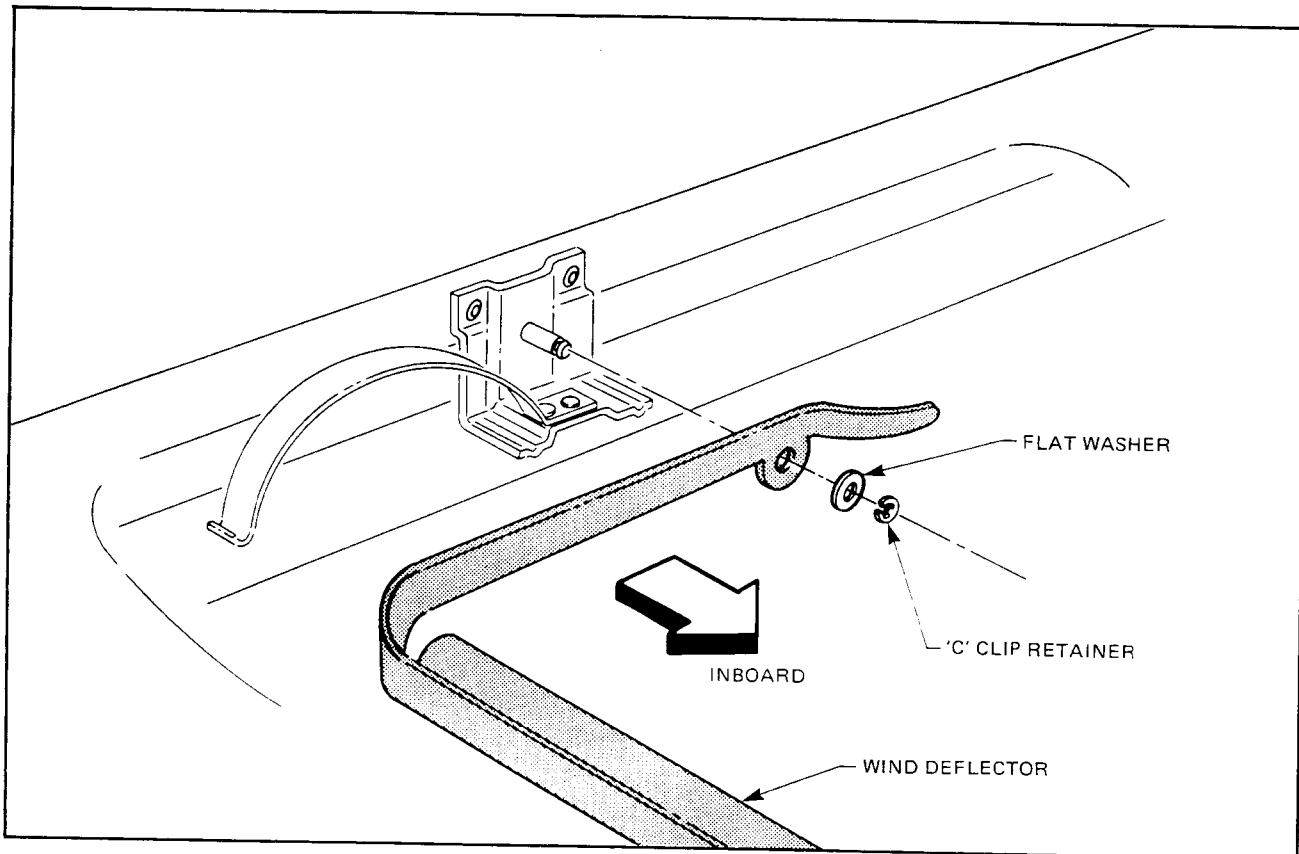

Figure 1A-73

9.6 LIMIT SWITCH ASSEMBLY

REMOVE

1. Remove welt and drop headliner from the front right side of the housing.
2. Scribe line on tube at tube entrance to switch assembly (refer Fig. 1A-74).
3. Remove two (2) switch assembly mounting screws (refer Fig. 1A-74).
4. Remove switch assembly by sliding off of tube.

REINSTALL

1. Prior to installation of new switch, remove cotter pin from switch assembly (refer Fig. 1A-74).
2. Position switch assembly to scribe line of tube. Attach with two (2) screws removed above.

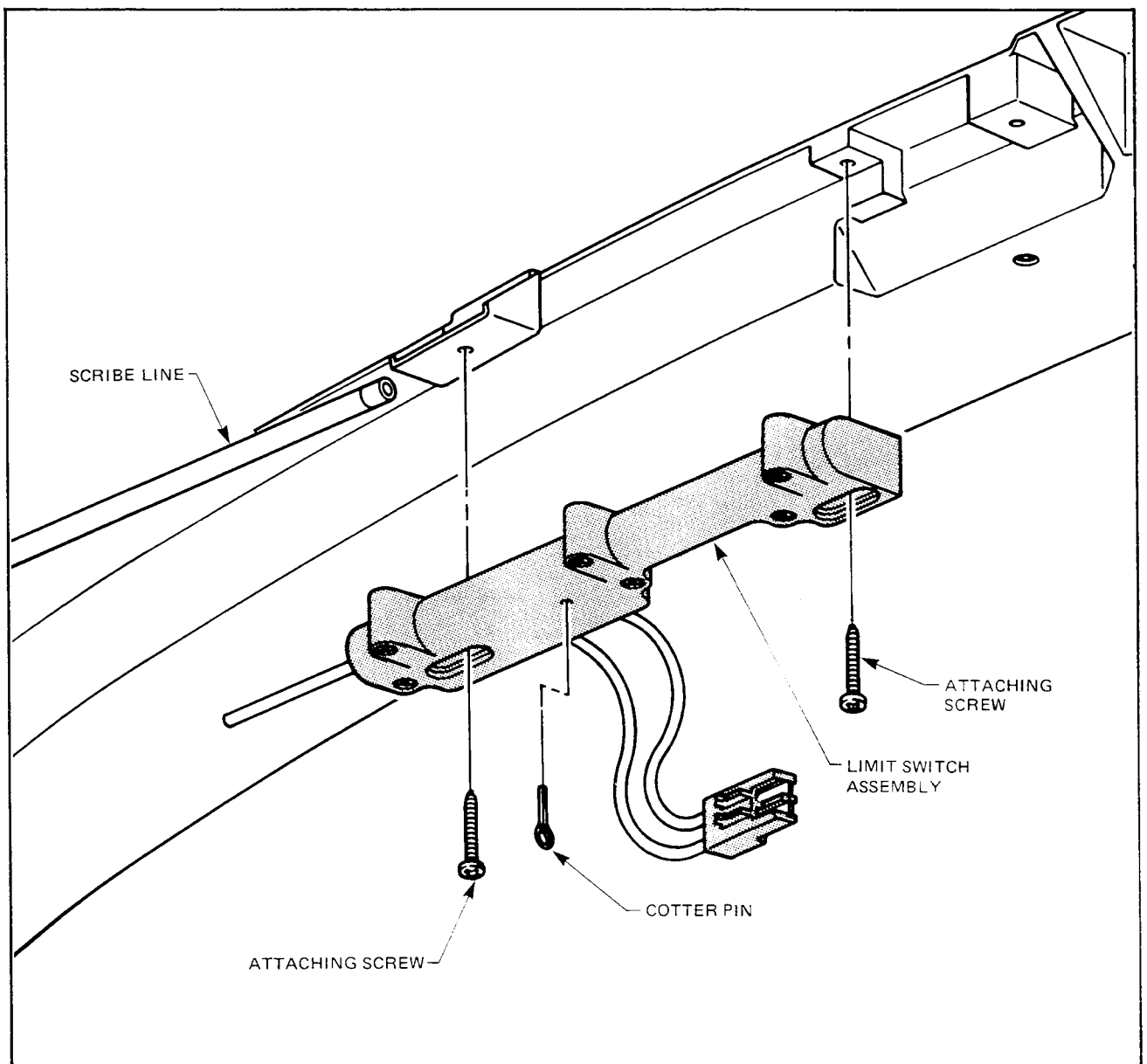

Figure 1A-74

1A-62 BODY

9.7 ELECTRONIC MODULE ASSEMBLY

REMOVE

1. Remove welt and drop headliner at front of housing.
2. Uncouple connector at module assembly.
3. Remove screws attaching module assembly to roof rail (refer Fig. 1A-75).

REINSTALL

Reverse removal operations.

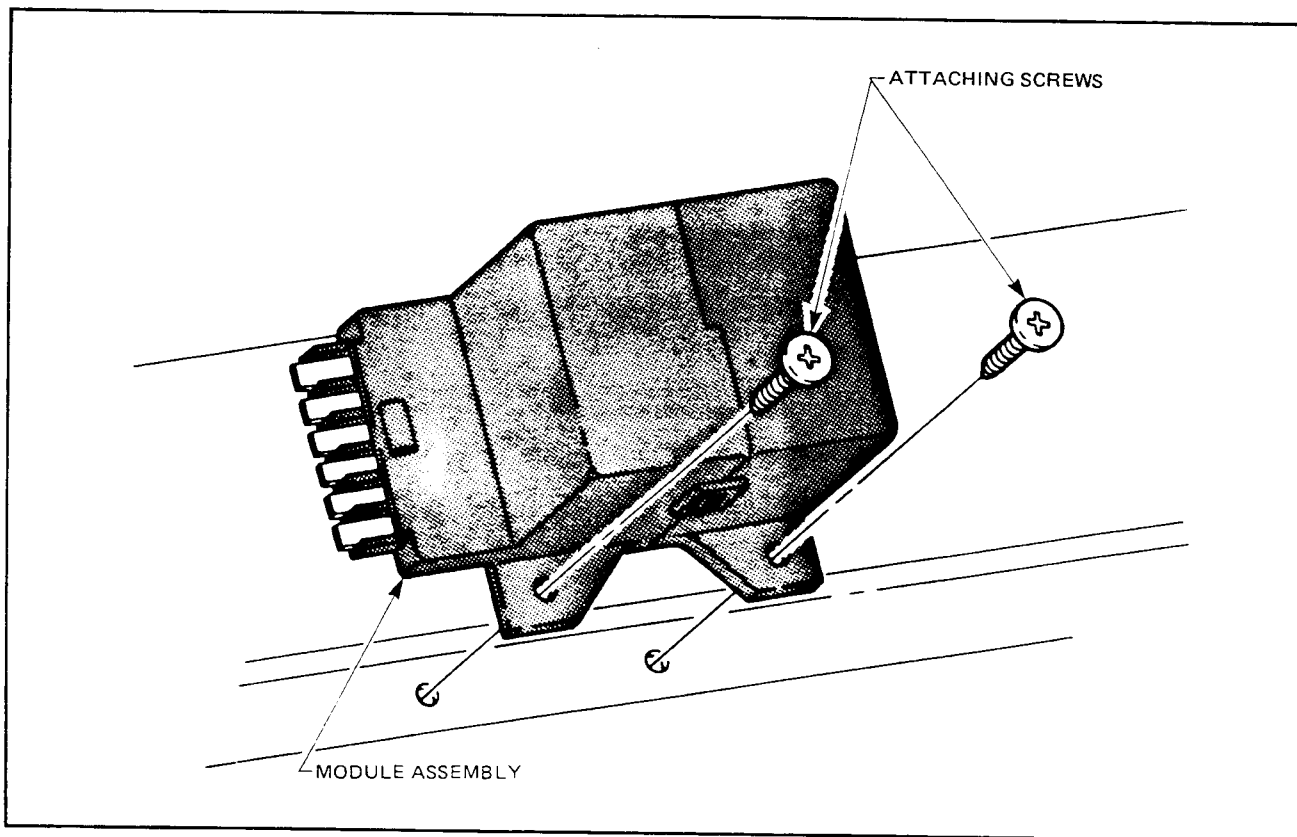

Figure 1A-75

9.8 CABLE ASSEMBLY

REMOVE

1. Drop headliner at rear of housing.
2. Remove cable guide lower retainer cover (refer Fig. 1A-76).
3. Disengage cables from drive gear (refer Fig. 1A-76).
4. Remove sliding panel as described in 8.4 Sunroof Sliding Glass Panel, Remove and Reinstall (refer Fig. 1A-69).

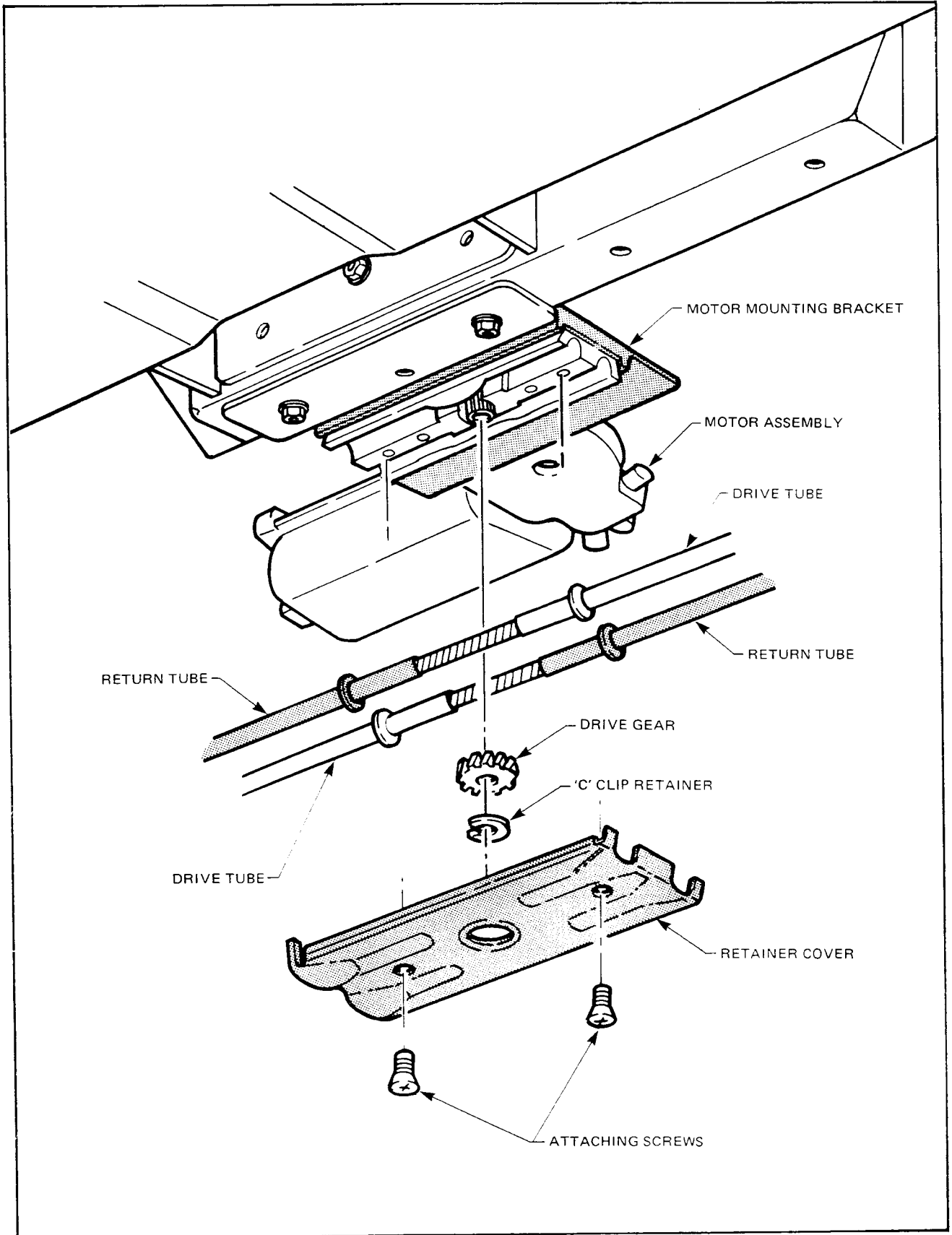

Figure 1A-76

1A-64 BODY

5. Move trough rod and cable assemblies rearward of notch in track, to slide front guide shoes rearward to notch, rotate and remove (refer Fig. 1A-77).
6. Rotate right hand front guide shoe forward to remove trough assembly (refer Fig. 1A-77).
7. Remove sunshade by adding a slight hand pressure upward to disengage front track.
8. Remove three (3) screws retaining each track (refer Fig. 1A-78).
9. Lift front of track up and disengage from housing.
10. Remove cable assembly from track at rear.

REINSTALL

Reverse removal operations using care to install sunshade in lowest slot in track. Refer to 'System Timing' (refer Fig. 1A-80).

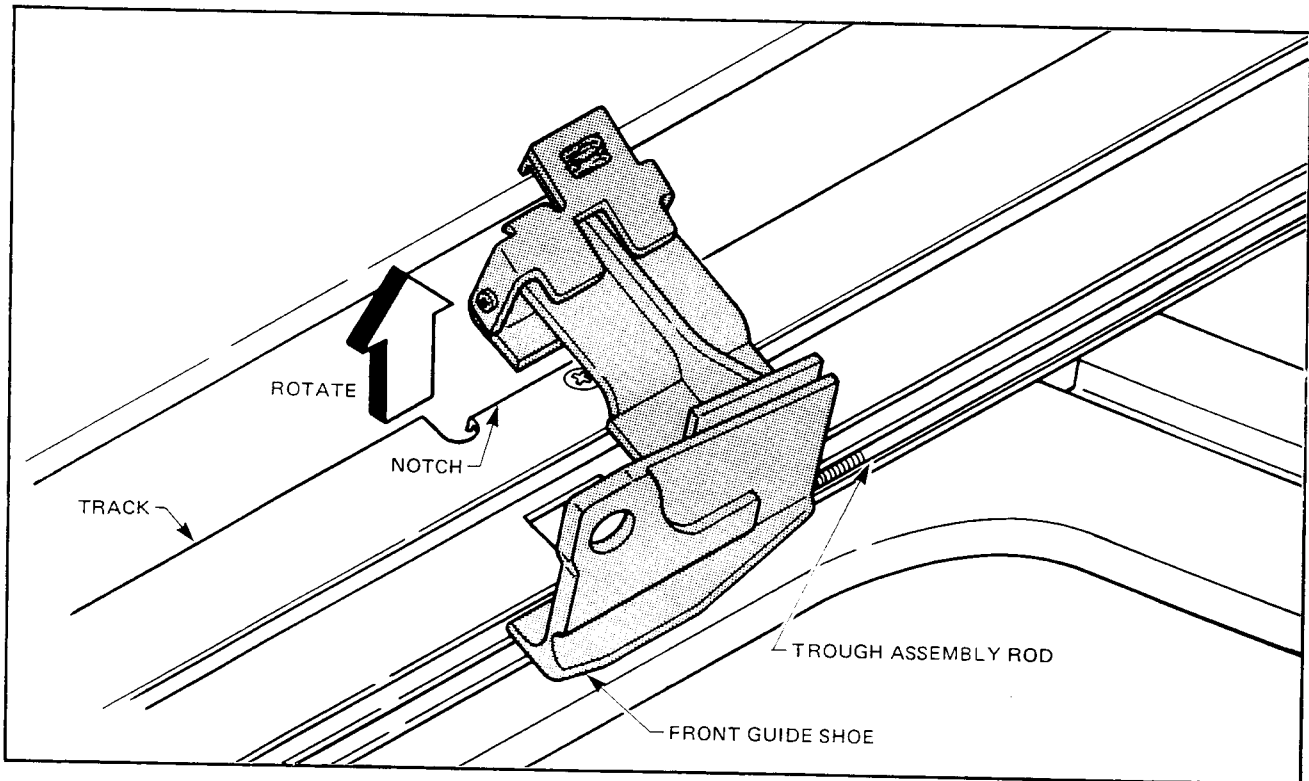

Figure 1A-77

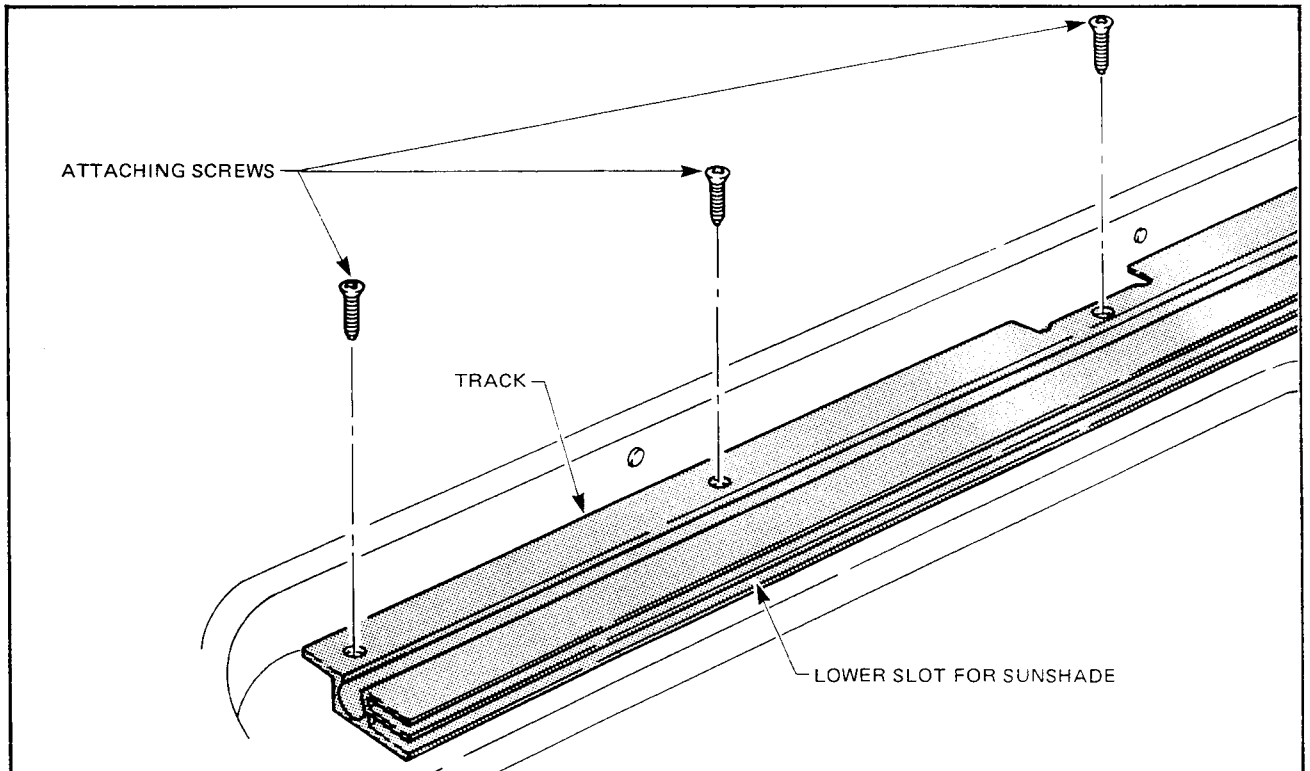

Figure 1A-78

9.9 SLIDING SUNROOF MOTOR ASSEMBLY

MOTOR ASSEMBLY REMOVAL

1. Drop headliner at rear of housing.
2. Uncouple connector from motor assembly.
3. Remove rear housing support brackets and lower rear of housing.
4. Remove two (2) hex head screws attaching motor to mounting brackets using 7 mm socket (refer Fig. 1A-79).

MOTOR ASSEMBLY REINSTALLATION

Reverse removal operations.

MOTOR DRIVE GEAR REMOVAL

1. Drop headliner at rear of housing.
2. Remove two (2) screws from cable guide lower retainer cover (refer Fig. 1A-76).
3. Use small screwdriver or other suitable tool to remove 'C' clip attaching drive gear to motor shaft (refer Fig. 1A-76).

MOTOR DRIVE GEAR REINSTALLATION

Reverse removal operations.

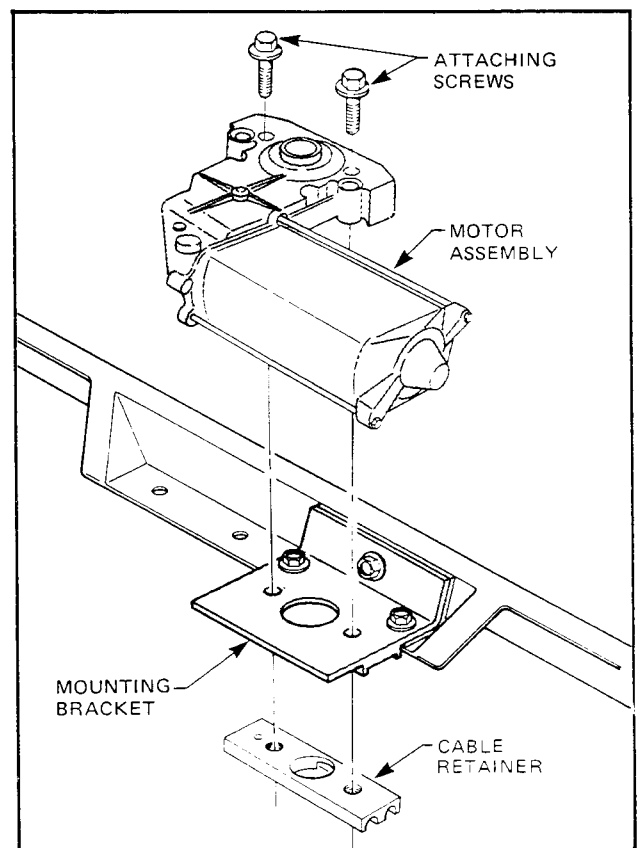

Figure 1A-79

1A-66 BODY

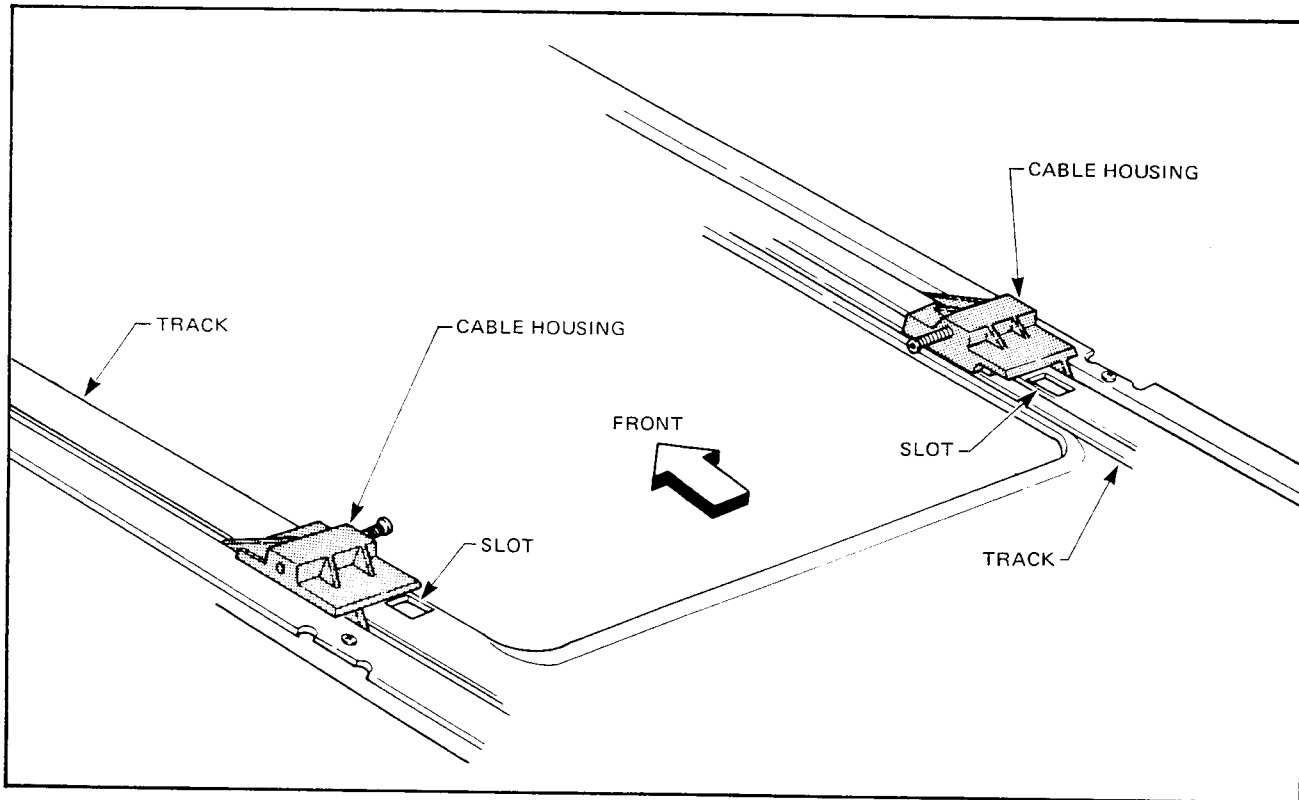
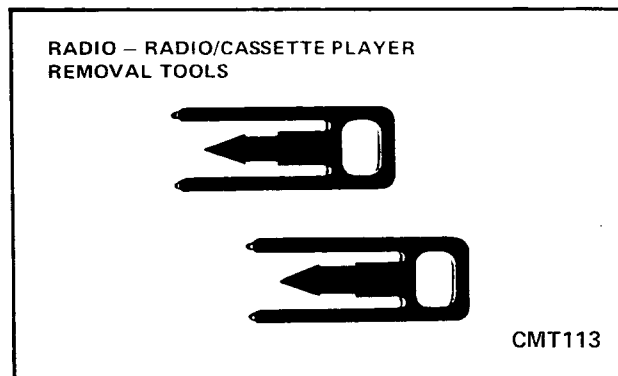
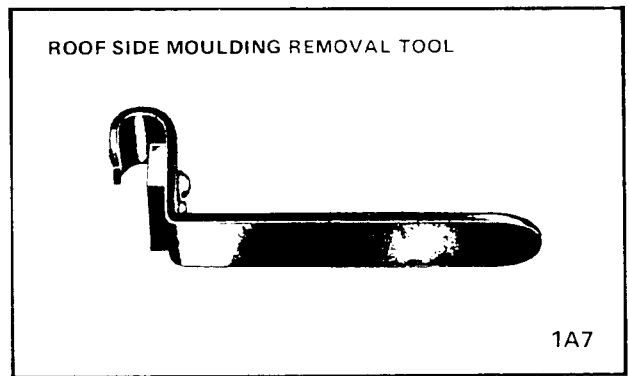
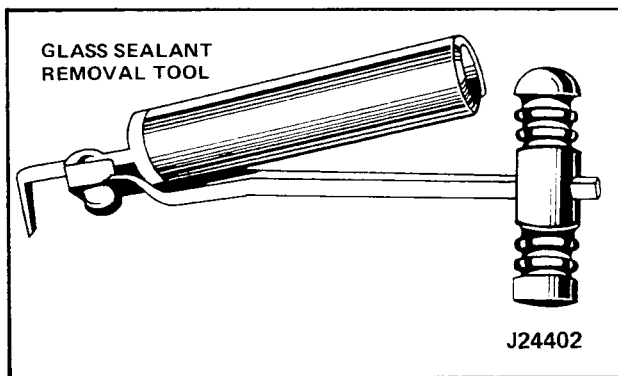
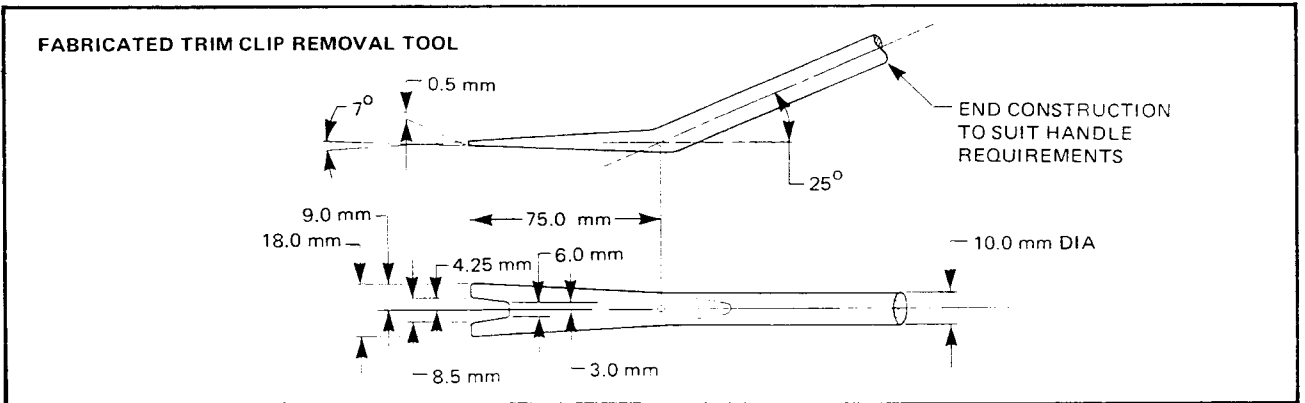

Figure 1A-80

9.10 SYSTEM TIMING

1. Remove drive gear from motor as described in 9.9 Sliding Sunroof Motor Assembly, Motor Drive Gear Removal and Reinstallation in this Section.
2. Position both cable housings to slots in tracks as shown in Fig. 1A-80.
3. Reinstall drive gear and reverse removal operations as described in 9.9 Sliding Sunroof Motor Assembly, Motor Drive Gear, Removal and Reinstallation in this Section.

10. SPECIAL TOOLS



SECTION 1C

RADIATOR GRILLE

INDEX

Ref.	Subject	Page	Ref.	Subject	Page
1.	DESCRIPTION	1C-1	1.1	SERVICE NOTES	1C-1
				Remove	1C-1
				Reinstall	1C-1

1. DESCRIPTION

The new one piece plastic radiator grille fitted to VK series is painted silver on Calais model, whilst on other

models, they are painted cool or warm grey, depending on the body colour.

1.1 SERVICE NOTES

Remove

1. With engine hood raised, remove screws securing grille to radiator upper support (refer Fig. 1C-1).
2. Ease top of grille forward, then lift grille pegs out of grommets installed in the bumper fascia.

Reinstall

Reverse removal operations.

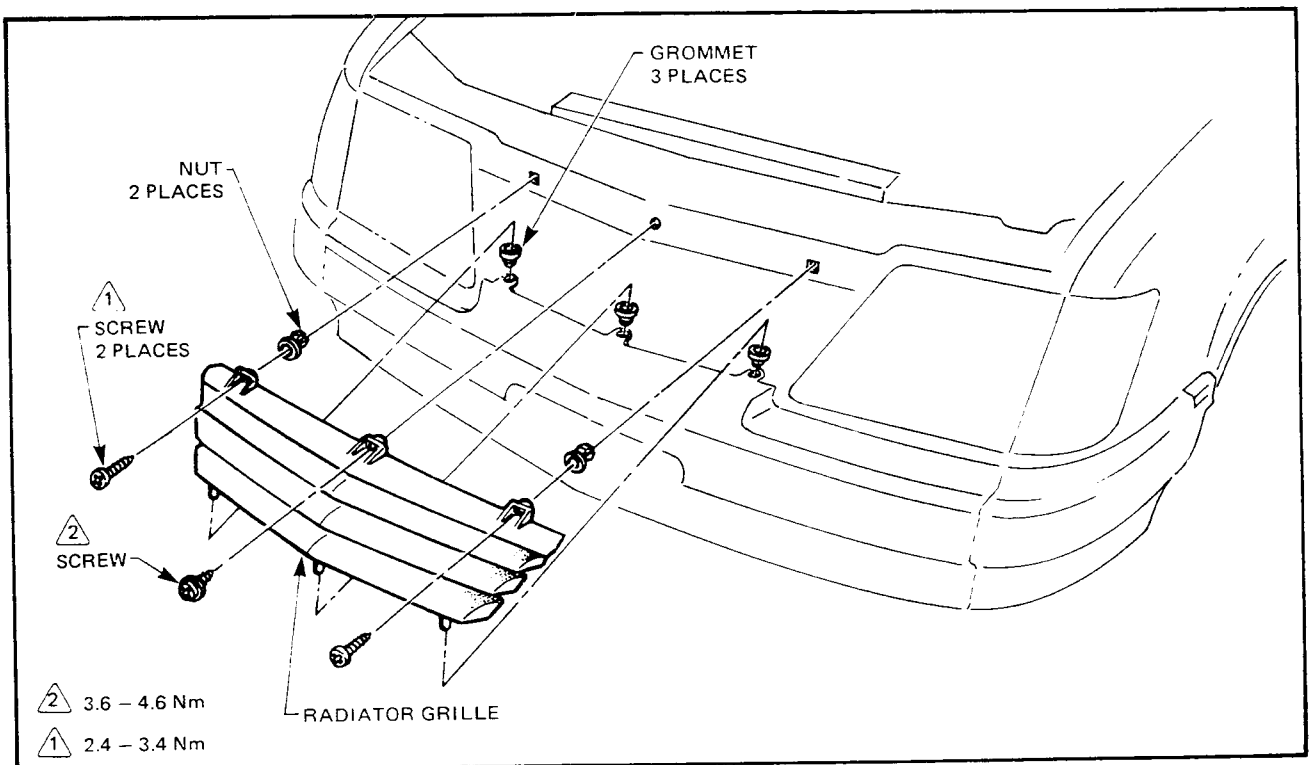

Figure 1C-1

SECTION 1D

FRONT & REAR BUMPER BAR ASSEMBLIES

INDEX

Ref.	Subject	Page	Ref.	Subject	Page
1.	DESCRIPTION	1D-1	1.3	REAR BUMPER BAR ASSEMBLY	1D-4
1.1	SERVICE NOTES	1D-1		Models 19 Body Styles.....	1D-4
	Introduction	1D-1		Remove	1D-4
	Recommended Materials	1D-2		Disassemble.....	1D-4
	Colour Finishing of Replacement			Reassemble	1D-4
	Parts	1D-3		Reinstall	1D-4
	Repairing Colour Coat	1D-2		Models 35 Body Styles.....	1D-6
	Warning - Use of Body			Remove.....	1D-6
	Colour Lacquer.....	1D-2		Disassemble.....	1D-6
1.2	FRONT BUMPER BAR ASSEMBLY	1D-3		Reassemble	1D-6
	Remove.....	1D-3		Reinstall	1D-6
	Disassemble.....	1D-3			
	Reassemble	1D-3			
	Reinstall	1D-3			

1. DESCRIPTION

Front and rear bumper bar assemblies fitted to VK models are of polycarbonate construction. Bright finishing strips featuring a rubber upper edge are clipped over the top edge of the side and part of the centre front bumper facias. On the rear bumper assemblies fitted to 19 body

styles, the finishing strips cover the complete upper edge of the rear bumper bar assembly whilst on the 35 body styles these finishing strips are fitted to the rear bumper facias only (refer Figs. 1D-1, 1D-2, 1D-3 and 1D-4).

1.1 SERVICE NOTES

INTRODUCTION

The paint system for the VK bumpers and side mouldings is relatively straight forward as long as the correct materials are used. If normal refinish lacquers and solvents are applied the polycarbonate will be damaged by solvent attack. Therefore, a warning label will be attached to the exterior surface of all unpainted spare parts supplied to the field.

CAUTION:

Painting - *Cleansing of this part for painting must be by methylated spirits wipe only. Do not use lacquer thinners or other cleaning thinners, as these may damage the plastic. Top Coat with GMH approved paint and thinners as specified in this Section.*

The following service recommendations are compiled to guide Dealerships, on the correct materials and methods to be employed when refinishing VK Series bumper bars and side mouldings, also when preparing new parts for service installation.

1D-2 FRONT & REAR BUMPER BAR ASSEMBLIES

RECOMMENDED MATERIALS

Front and rear bumper bars and side mouldings installed to VK Series are made from high impact strength polycarbonate plastic.

It is essential that only GMH approved materials, paints and thinners, be employed when paint repair operations are performed and when preparing new parts for installation to the vehicle.

Use of the wrong materials will affect finished quality and will affect the polycarbonate material.

The GMH approved materials are:

- Methylated Spirits - for cleansing before painting.
- Paint - Berger Polycarbonate Lacquer in the following colours:

Silver	—	GMH 4J022	—	Berger HH9991
Warm Grey	—	GMH 4H016	—	Berger HH9989
Cool Grey	—	GMH 4H015	—	Berger HH9990

- Thinner - Berger LT226.

The Berger lacquer is a special acrylic lacquer developed for polycarbonate and requires **NO** primer. The polycarbonate parts are moulded in-colour for ease of top coating. When ordering spare parts quote the GMH colour number and name, for example Warm Grey (GMH 4H016).

COLOUR FINISHING OF REPLACEMENT PARTS

Spare parts are supplied unpainted, to be coated before installation to the vehicle.

Observe the following procedures:-

1. **Order part** with the plastic self coloured to match the required top coat colour.
2. **Inspect surface**, if slight transit damage is present this can be rectified by dry sanding with P400 paper.
3. **Cleaning** - wipe the surface at least twice using a clean cloth soaked in methylated spirits, wiping dry with a new clean cloth each time.
4. **Paint** - mix the polycarbonate lacquer to spraying viscosity with approved thinners (approximately 1:1 ratio), and apply one full wet coat. Allow about two minutes flash time and apply a second full coat. It is important that only sufficient paint to achieve coverage is applied, too high a paint thickness may reduce adhesion. (Correct film thickness is 30 - 35 microns.)
5. **Drying** - allow 10 minutes air flash then use a heat lamp or similar set up to warm the painted surface for 30 minutes (part surface temperature should not exceed 90°C). Lamp baking will speed removal of the special slow solvents in the lacquer and harden the paint film to enable assembly of the part to the vehicle.

REPAIRING COLOUR COAT

Superficial damage to the paint film and/or plastic surface may be rectified by sanding and repainting. Parts having deep gouges etc. in the plastic surface should be replaced as repair methods using filling materials and thinning down of the plastic section may reduce overall impact strength. Under no circumstances should paint be washed off with lacquer thinners. (i.e. Sections of the

Bumper) The paint repair area should be to the nearest convenient breakline. Spot repairs are not recommended due to possible colour match problems.

1. **Sanding** - depending upon the degree of damage, P320 (or coarser grit) wet or dry sandpaper may be required for initial sanding. Finish sand with P400 grit paper to remove sanding marks and dry scuff all over the whole of the area to be resprayed.
2. **Cleaning** - wipe the area to be painted at least twice with a clean cloth soaked in methylated spirits wiping dry with a new clean cloth each time.
3. **Painting** - mix the polycarbonate lacquer with approved thinners (approximately 1:1 ratio) and spray the repaired area to build colour followed by one wet coat all over to achieve colour uniformity.
4. **Drying** - allow 10 minutes air flash then use a heat lamp or similar set up to warm the painted surface for 30 minutes. (Surface temperature of the part should not exceed 90°C.) Lamp baking will speed removal of the special slow solvents in the lacquer and harden the paint film.

WARNING - USE OF BODY COLOUR LACQUER

Normal lacquers used for refinish painting of sheet metal are not suitable for repainting the VK polycarbonate bumpers and side mouldings.

FRONT & REAR BUMPER BAR ASSEMBLIES 1D-3

1.2 FRONT BUMPER BAR ASSEMBLY

REMOVE

1. Raise and support front end of vehicle on jack stands.
2. From within front end section of front wheel openings, remove screws securing sides of front bumper bar assembly to front fenders (refer Sections B-B and C-C, Fig. 1D-1).
3. With front bumper bar assembly fully supported and from under front of vehicle, remove bolts securing inner bracket assemblies from side frames (refer Section A-A, Fig. 1D-1) removing front bumper bar assembly.

Disassemble

1. Disengage lower edge of finishing strip assembly from notch in bumper bar side facia(s) (refer Section C-C, Fig. 1D-2) then raise and remove finishing strip.
2. Remove screws securing bumper bar facias to front bumper bar inner bracket assemblies (refer Section A-A, Fig. 1D-2).
3. Remove screws and nuts securing side facia(s) to centre facia (refer Section B-B, Fig. 1D-2) then remove side facia(s).

Reassemble

Reverse to disassembly operations.

REINSTALL

Reverse to removal operations.

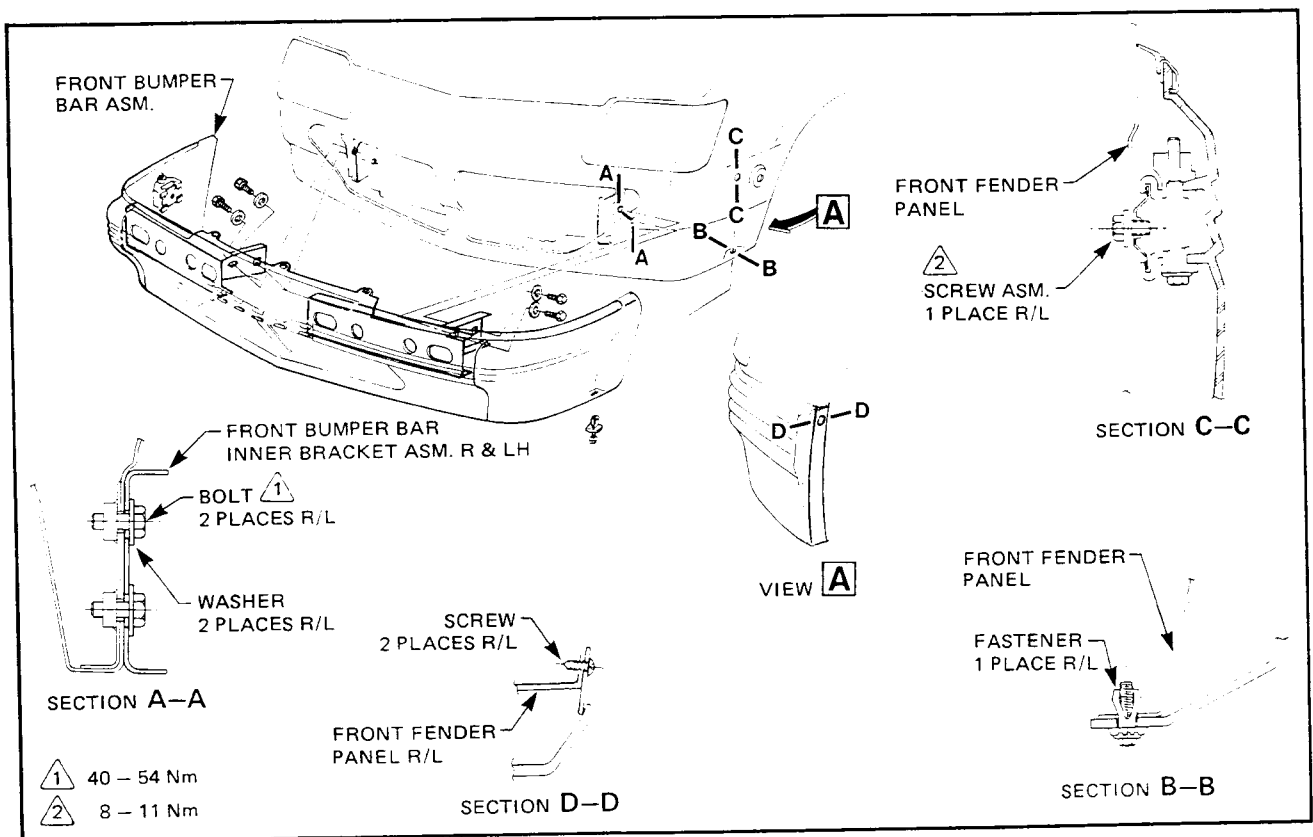

Figure 1D-1

1D-4 FRONT & REAR BUMPER BAR ASSEMBLIES

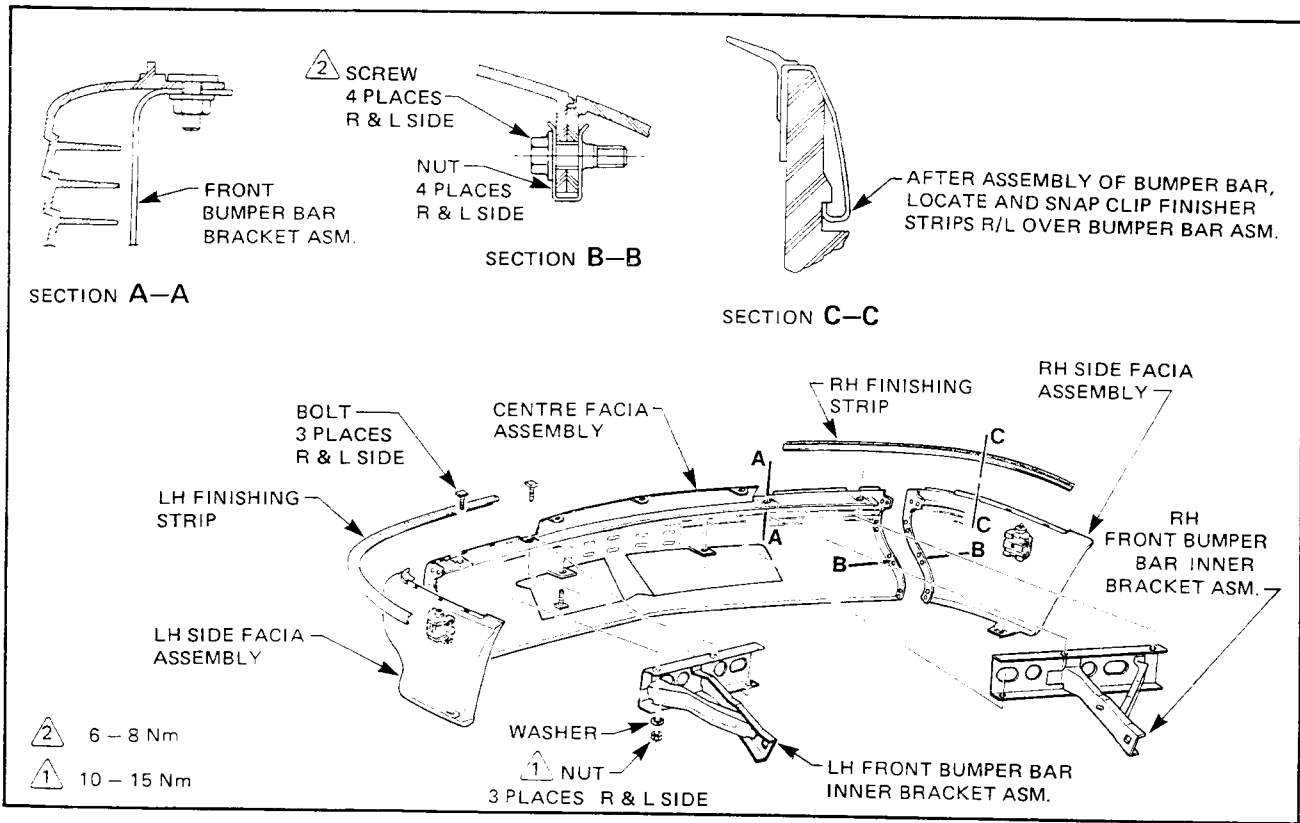

Figure 1D-2

1.3 REAR BUMPER BAR ASSEMBLY

MODELS 19 BODY STYLES

Remove

1. From under rear quarter panels, remove screws securing lower section of side facias to rear quarter panel (refer Section C-C, Fig. 1D-3).
2. With rear bumper bar assembly fully supported, remove nuts and screws securing rear bumper bar assembly to rear end of vehicle (refer Sections A-A and B-B, Fig. 1D-3) and unscrew licence plate holder from centre facia then remove assembly.

Disassemble

1. Disengage lower edge of finishing strip assembly from notches in right and left hand sides of bumper bar assembly (refer Fig. 1D-3) then raise and remove finishing strips.
2. Remove screws and nuts securing bumper bar assembly mounting brackets to centre facia and side facia(s) to centre facia (refer Sections B-B and D-D, Fig. 1D-3) then remove side facia(s).

Reassemble

Reverse disassembly operations.

Reinstall

Reverse removal operations ensuring that the sealing instructions for the rear bumper bar assembly attaching screws and nuts illustrated Fig. 1D-3 are observed.

FRONT & REAR BUMPER BAR ASSEMBLIES 1D-5

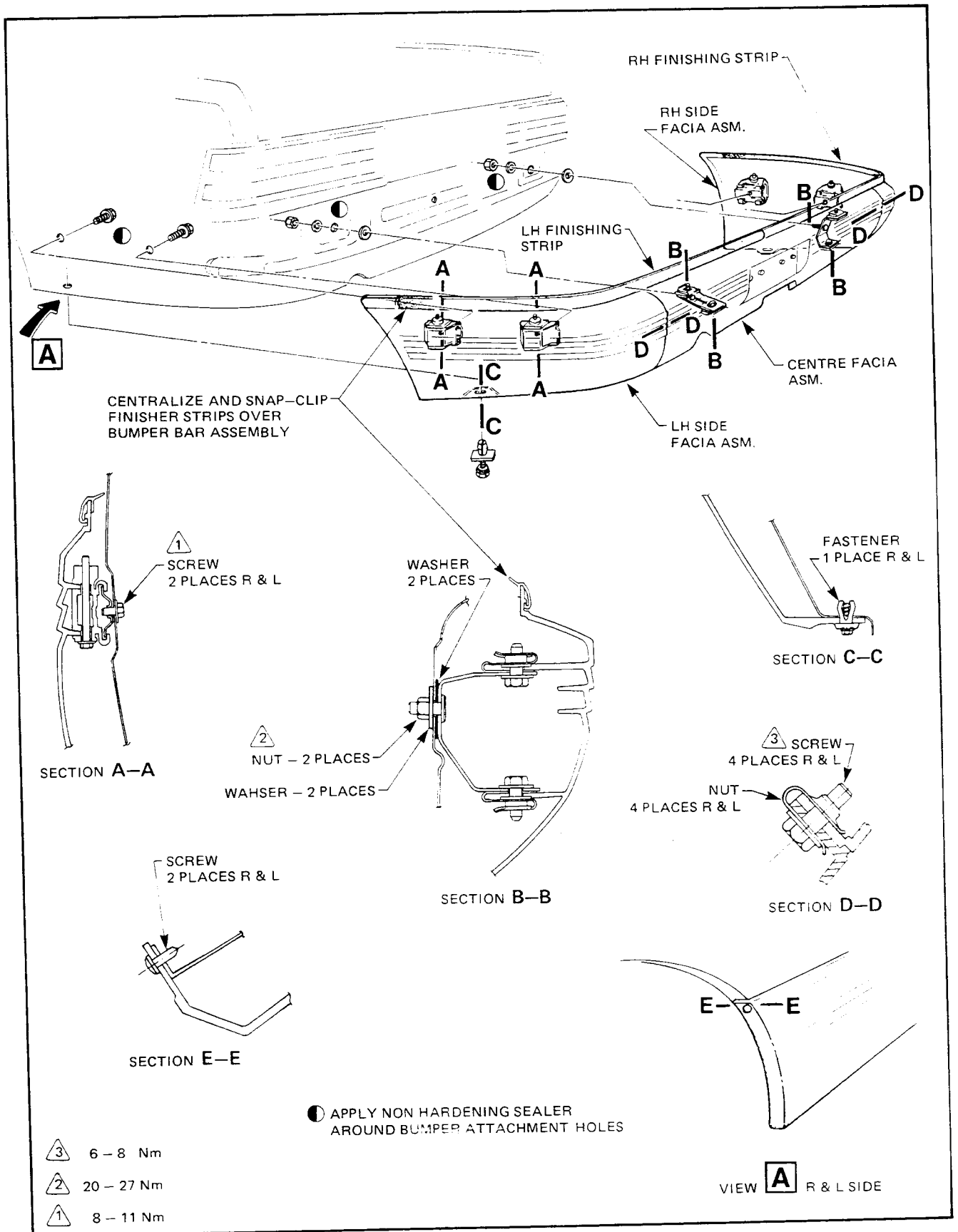

Figure 1D-3

1D-6 FRONT & REAR BUMPER BAR ASSEMBLIES

MODELS 35 BODY STYLES

Remove

1. Disconnect battery ground cable then carefully prise out licence plate lamp assemblies from top of centre facia and disconnect electrical connectors.
2. From under rear quarter panels, remove screws securing lower section of side facias to rear quarter panel (refer Section C-C, Fig. 1D-4).
3. With tailgate raised and rear quarter inner trim panel covers removed, remove screws securing rear bumper bar assembly to rear quarter panel (refer Section A-A, Fig. 1D-4).
4. From within spare wheel compartment and with rear bumper bar assembly fully supported, remove nuts securing assembly to back panel lower (refer Section B-B, Fig. 1D-4) and remove assembly.

Disassemble

1. Disengage lower edge of finishing strip assembly from notches on side facia(s) (refer Section A-A, Fig. 1D-4) then raise and remove finishing strip(s).
2. Remove nuts and screws securing bumper bar assembly mounting brackets to centre facia and centre facia to side facia(s) (refer Sections B-B and D-D, Fig. 1D-4) then remove side facia(s).

Reassemble

Reverse disassembly operations.

Reinstall

Reverse removal operations ensuring that the sealing instructions for the rear bumper bar assembly attaching screws and nuts illustrated in Fig. 1D-4 are observed.

FRONT & REAR BUMPER BAR ASSEMBLIES 1D-7

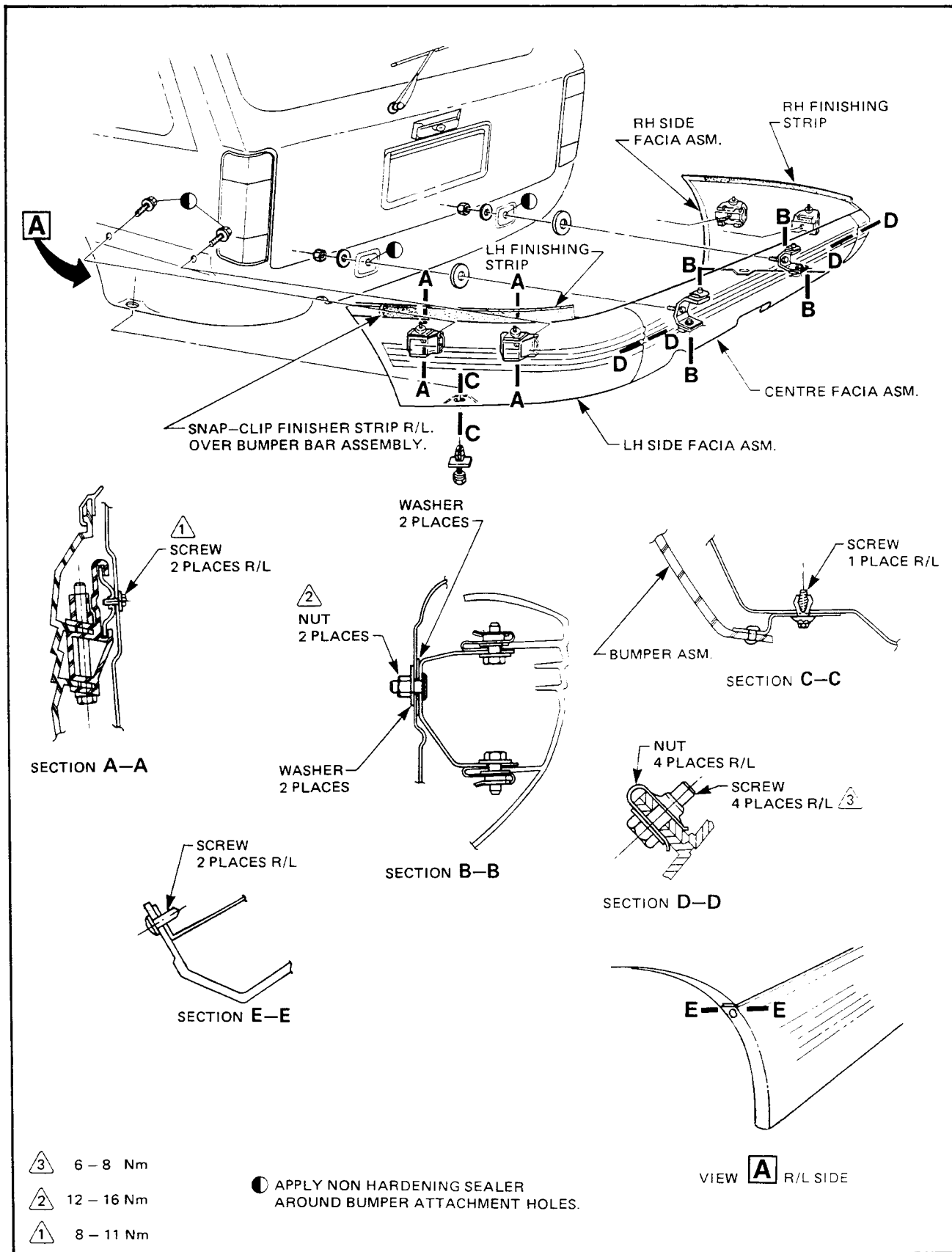

Figure 1D-4

SECTION 2A

VENTILATION & HEATING

INDEX

Ref.	Subject	Page	Ref.	Subject	Page
1.	GENERAL DESCRIPTION	2A-3	1.5	BLOWER MOTOR	2A-9
1.1	MANUAL CONTROLS	2A-4		Remove.....	2A-9
	Dem	2A-4		Reinstall	2A-9
	Floor	2A-4	1.6	BLOWER MOTOR HOUSING ASSEMBLY ..	2A-10
	Vent	2A-4		Remove.....	2A-10
	Bi Level.....	2A-4		Reinstall	2A-10
	Off	2A-4	1.7	HEATER ASSEMBLY	2A-11
1.2	SERVICE NOTES	2A-6		Remove.....	2A-11
1.3	UPPER SIDE VENT OUTLETS, RIGHT &			Reinstall	2A-11
	LEFT HAND	2A-6	1.8	HEATER CORE AND PIPE ASSEMBLY	2A-13
	Remove.....	2A-6		Remove.....	2A-13
	Reinstall	2A-6		Reinstall	2A-13
1.4	MODE SELECTION, TEMPERATURE		1.9	WATER VALVE ASSEMBLY - HEATER	
	CONTROL AND BLOWER FAN SWITCH ..	2A-7		CORE	2A-14
	Models - All	2A-7		Remove.....	2A-14
	Remove.....	2A-7		Reinstall	2A-14
	Reinstall	2A-7			

2A-2 VENTILATION & HEATING

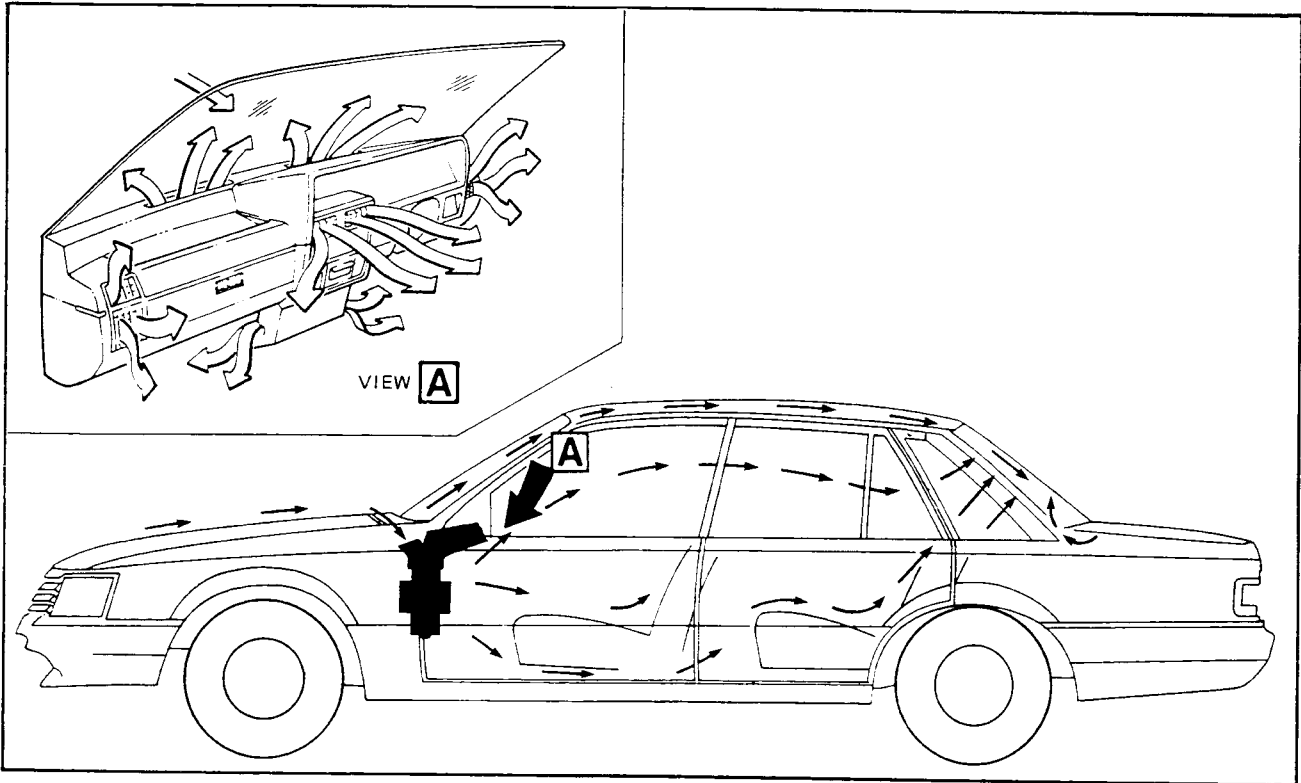

Figure 2A-1

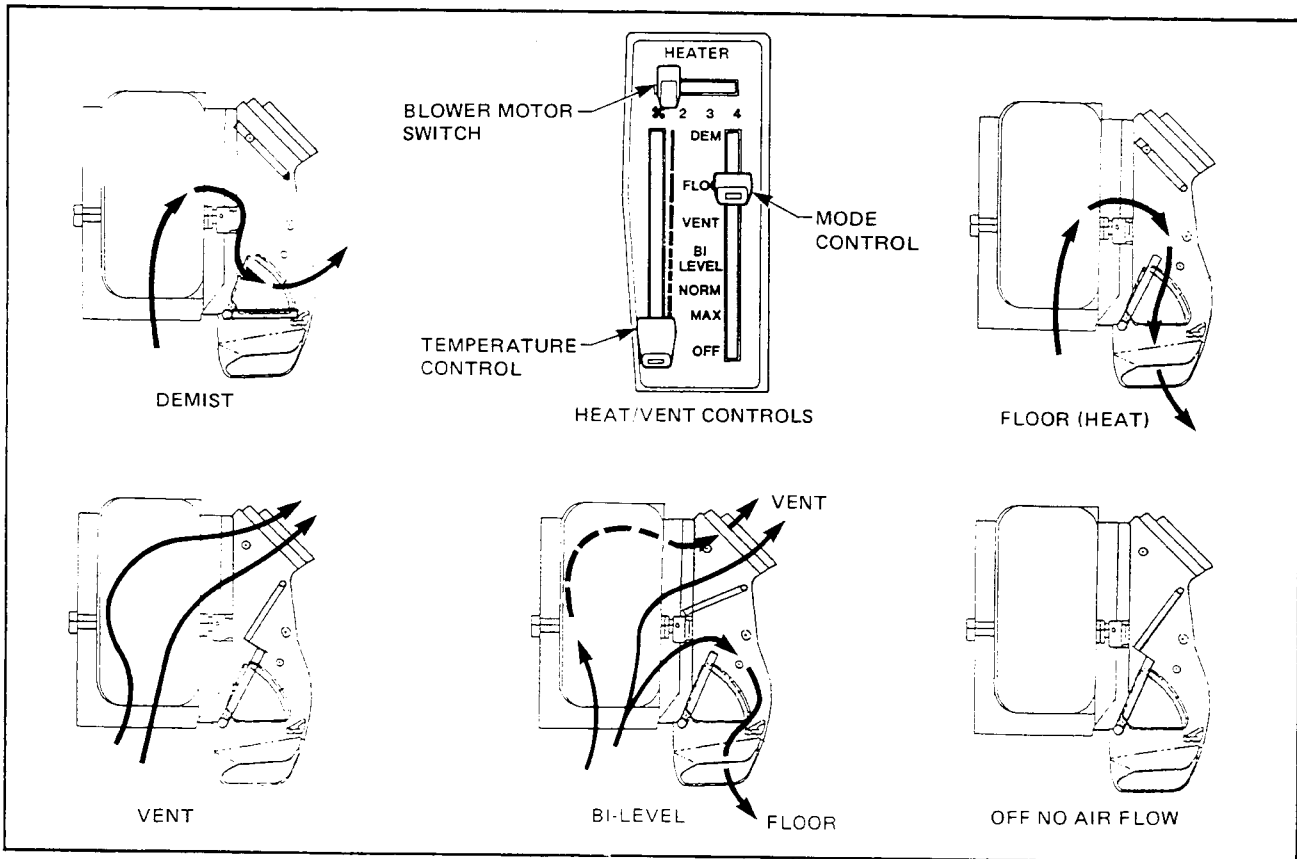

Figure 2A-2

1. GENERAL DESCRIPTION

The ventilating and heating system featured on VK Series models allows air entering the system via the grilles at the rear of the engine hood to pass through the blower motor housing and heater assemblies and to be heated, mixed or allowed to remain at ambient temperature, as required. The air then enters the passenger compartment through the centre and or side upper ventilator outlets, or through the demist or footwell outlets (refer Fig. 2A-1) depending on the position of the mode or temperature control levers illustrated in Fig. 2A-2. Fig. 2A-2 also illustrates the air flow within the heater assembly with the various modes activated.

On sedans, air from the passenger compartment exhausts through ventilator outlets located behind the right and left hand side drip moulding assembly rear, illustrated in Fig. 2A-3. On station wagons, the air is exhausted via the edges of the rear quarter inner trim panels, into the roof, then out into the atmosphere through tailgate hinge pockets.

The volume of air from the centre or side upper ventilator outlets (refer View A, Fig. 2A-1) is controlled by a regulating wheel below the outlet inserts illustrated in Fig. 2A-4. The air flow can be directed as required by tilting and/or swivelling the ventilator upper outlet inserts. To stop the air supply from the upper side vent outlets, rotate the regulating wheel to the right, and on the centre air outlet, rotate the wheel downwards until a stop is reached.

The heating system utilises an air mix principle where the temperature of air entering the passenger compartment is controlled by a temperature lever illustrated in Fig. 2A-2 which operates the mixture door. This regulates the volume of air passing through the heater core.

The temperature, mode and blower motor control assembly illustrated in Fig. 2A-2 consists of a four speed fan switch, which regulates the rate at which forced air is delivered into the vehicle through the various outlets, and two sliding levers. The left hand lever controls the air temperature entering the vehicle in all modes and the right hand lever, the particular mode required.

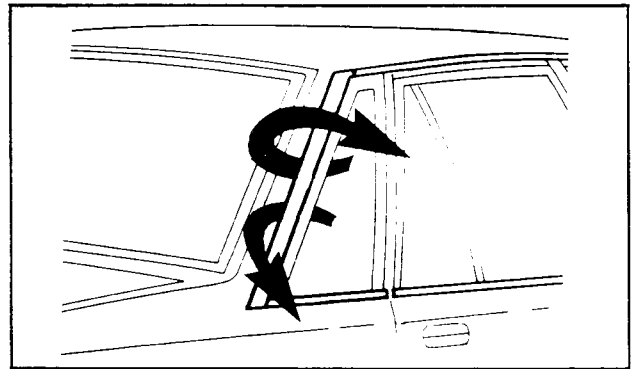

Figure 2A-3

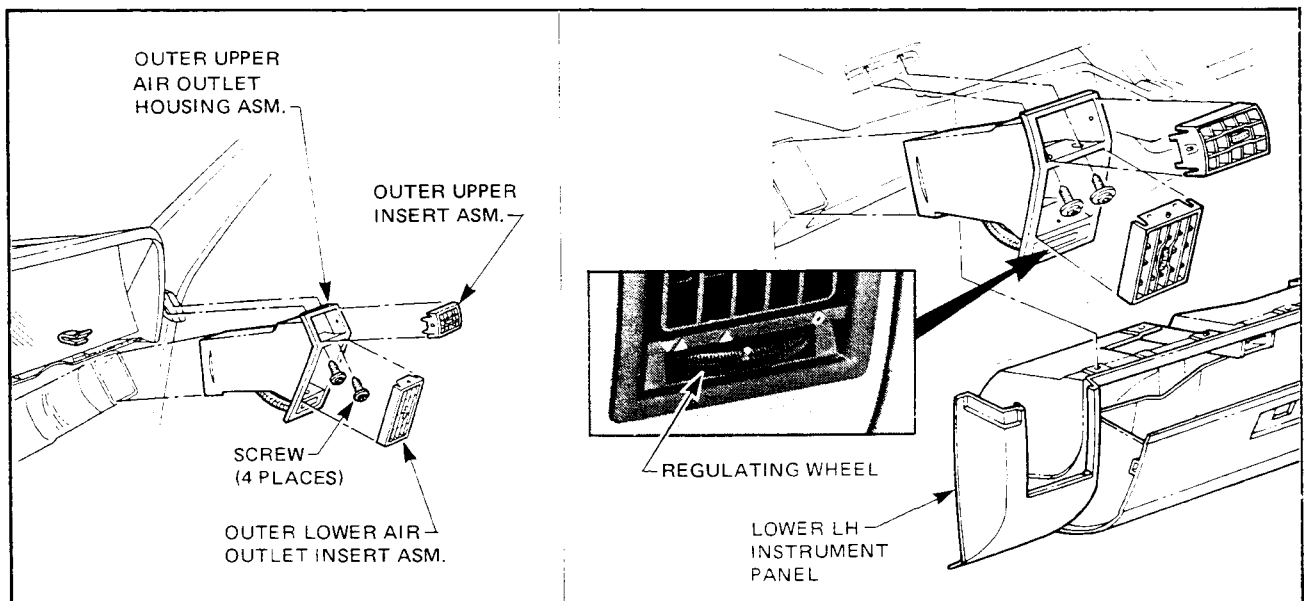

Figure 2A-4

2A-4 VENTILATION & HEATING

1.1 MANUAL CONTROLS

The mode control lever has five positions:

DEM

In this position the air flows onto the windscreen through the demist vents on top of the instrument panel. A small amount of air also goes to the floor outlets.

FLOOR

In this position the main air flow is directed to the floor outlets with a small amount going to the demist vents.

VENT

This setting directs all the ambient or heated air to the centre and side vents. The air flow and direction can be individually adjusted at each vent.

BI LEVEL

This position directs air to the centre and side vents as well as to the floor vents.

OFF

In this position the fan is switched off and no outside air is admitted via the ventilation system. This setting is only recommended to be used for short periods when driving in very dusty or smokey conditions with all the windows closed. Return the mode lever to one of the other settings as soon as conditions permit.

NOTE: The blower motor fan automatically switches on to its lowest speed when the mode control lever is moved away from OFF position. Fan speed can then be increased by selecting a higher number.

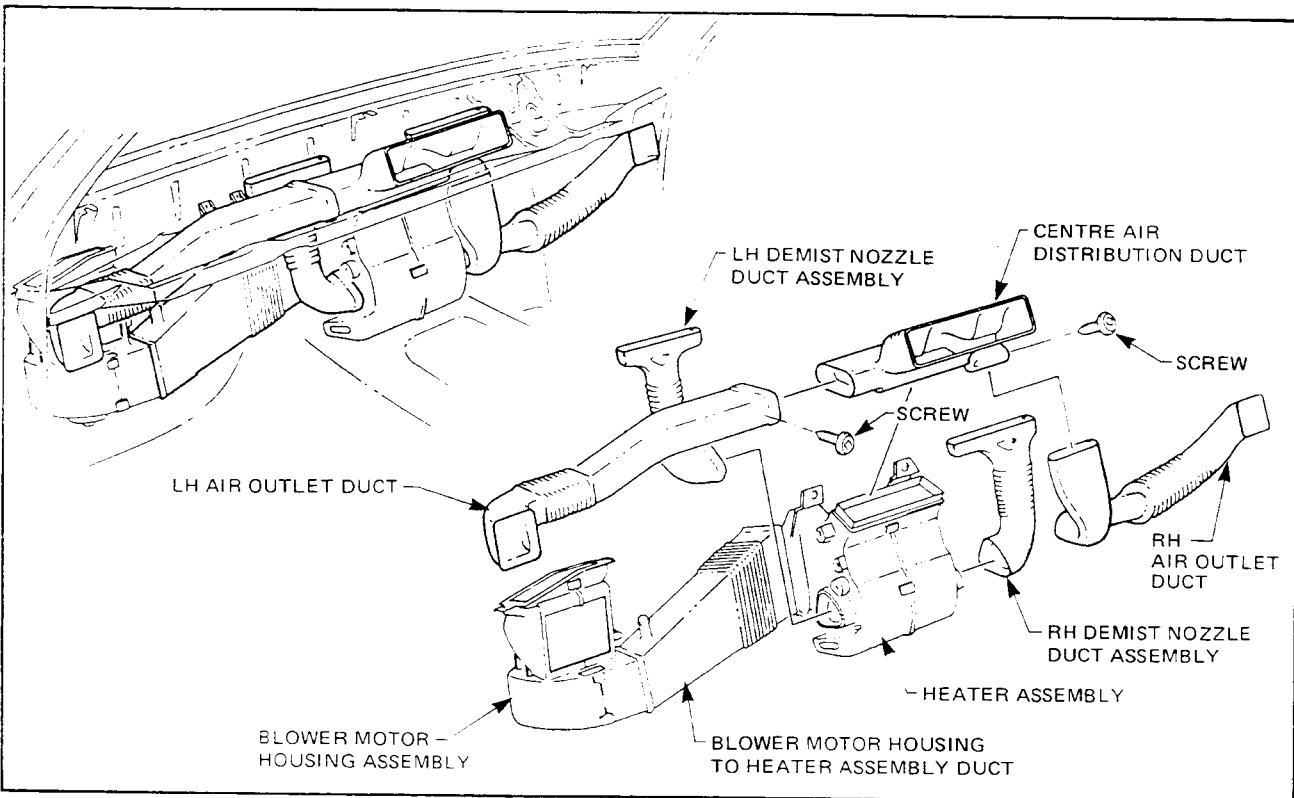

Figure 2A-5

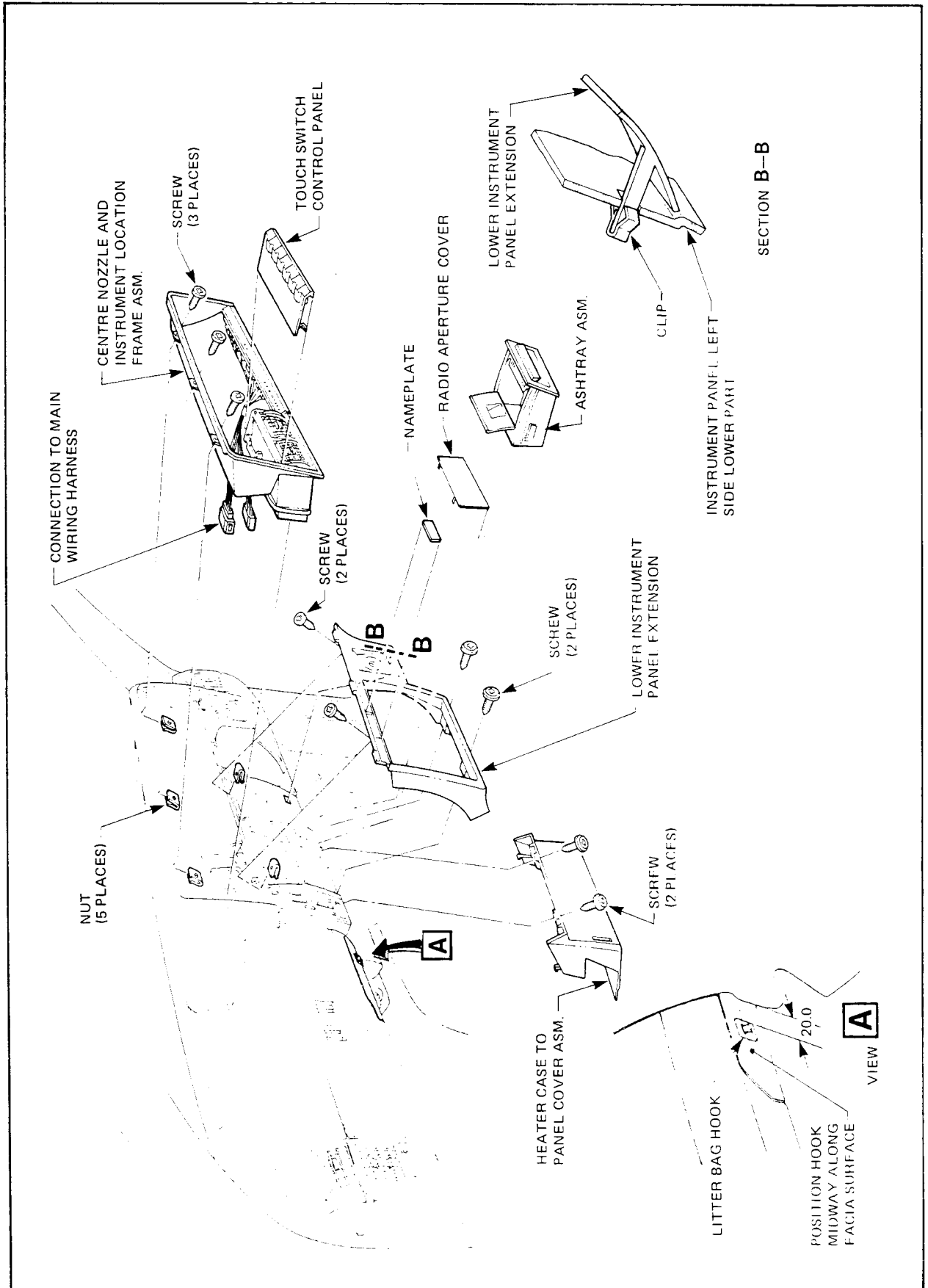

Figure 2A-6

2A-6 VENTILATION & HEATING

1.2 SERVICE NOTES

The non air conditioned air ducting on VK Series illustrated in Fig. 2A-5 is polypropylene tubing with mating indentations and protrusions which retain the ends of the ducting together. Screws installed through the right and left hand air outlet ducting to the centre air distribution duct, ensure correct retention of the ducting in its designed location. Should any of this air ducting be disturbed during under instrument panel operations, it is essential to ensure that such ducting be correctly reinstalled so as to prevent possible air leaks at these joins and connections.

Removal of any of the ducting necessitates removal of the instrument panel lower trim on the side from which the ducting is to be removed. Other than the blower housing to heater assembly duct, removal of other ducting necessitates removal of the touch control panel and the instrument panel location cover illustrated in Fig. 2A-6.

1.3 UPPER SIDE VENT OUTLETS, RIGHT & LEFT HAND

REMOVE

Using a fine bladed screwdriver, carefully prise right hand and left hand upper and lower inserts from within side vent upper assemblies prior to removing screws, securing the upper air outlet assemblies to the instrument panel pad assembly as illustrated in Fig. 2A-7, then remove outlet assembly.

REINSTALL

Reverse removal procedures.

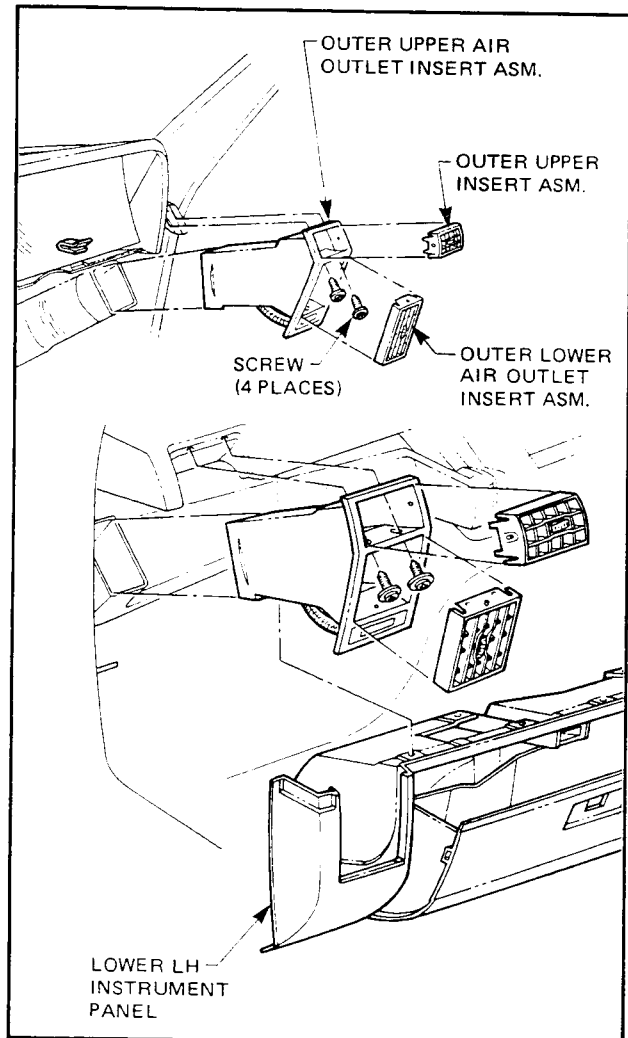

Figure 2A-7

1.4 MODE SELECTION, TEMPERATURE CONTROL AND BLOWER FAN SWITCH

MODELS - ALL

Remove

1. Disconnect the battery earth cable.
2. Remove the transmission console assembly (refer 2.2, Body Section of this Supplement).
3. From the left hand side of the heater assembly, disengage the front end of the control cable from the temperature door rod, illustrated in View B, Fig. 2A-8.
4. Remove the touch switch control panel and the centre nozzle and instrument location frame assembly illustrated in Fig. 2A-9.
5. Remove the temperature, mode, booster fan and wiper dwell control knobs.
6. Remove the lower instrument panel extension illustrated in Fig. 2A-9.

NOTE: Do not remove the wiper dwell control switch.

7. Remove the screw securing the top of the temperature and mode control assembly to the instrument panel frame illustrated in Fig. 2A-8, then partly ease out assembly, disconnecting mode control vacuum hoses and electrical connector.
8. Remove the rear end of the cable from the temperature control lever.

Reinstall

Reverse removal procedures.

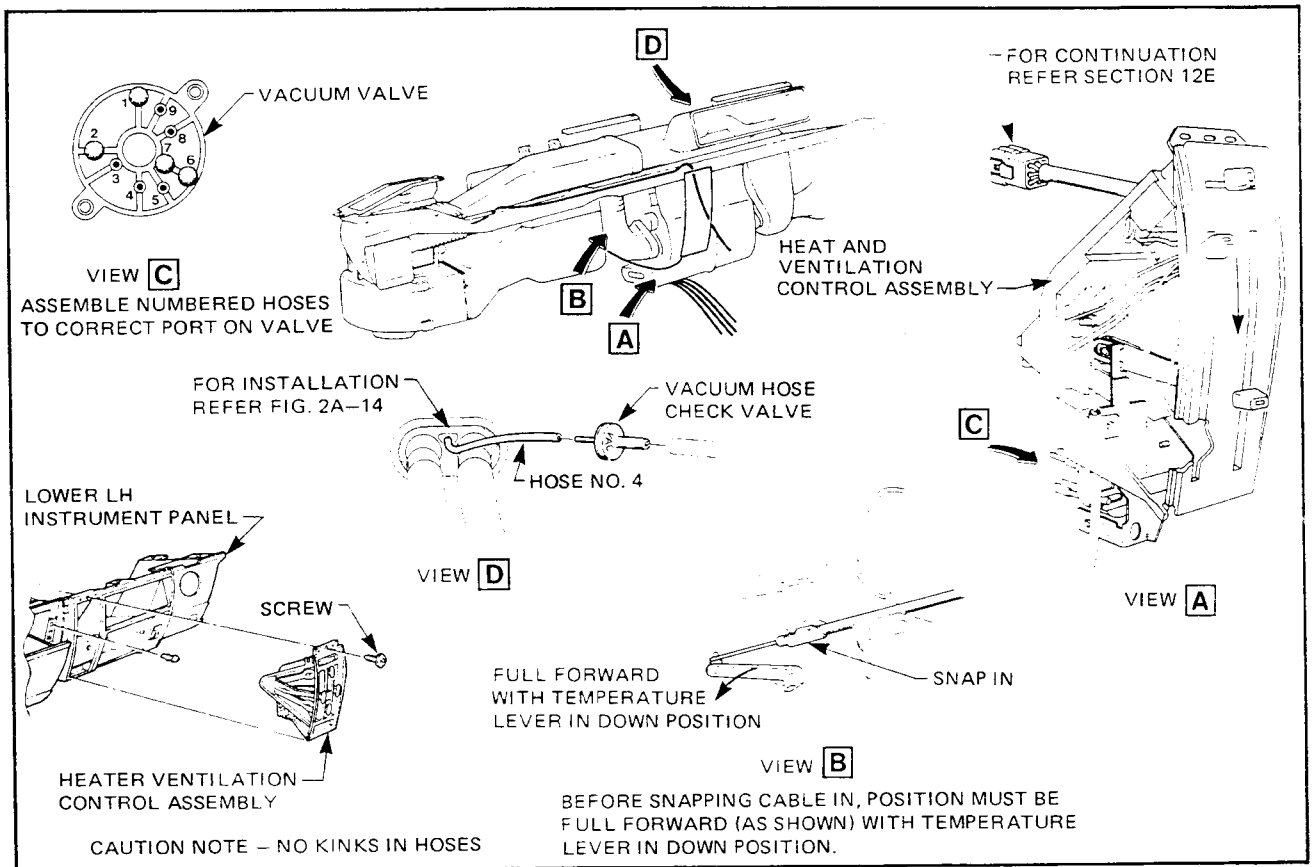

Figure 2A-8

2A-8 VENTILATION & HEATING

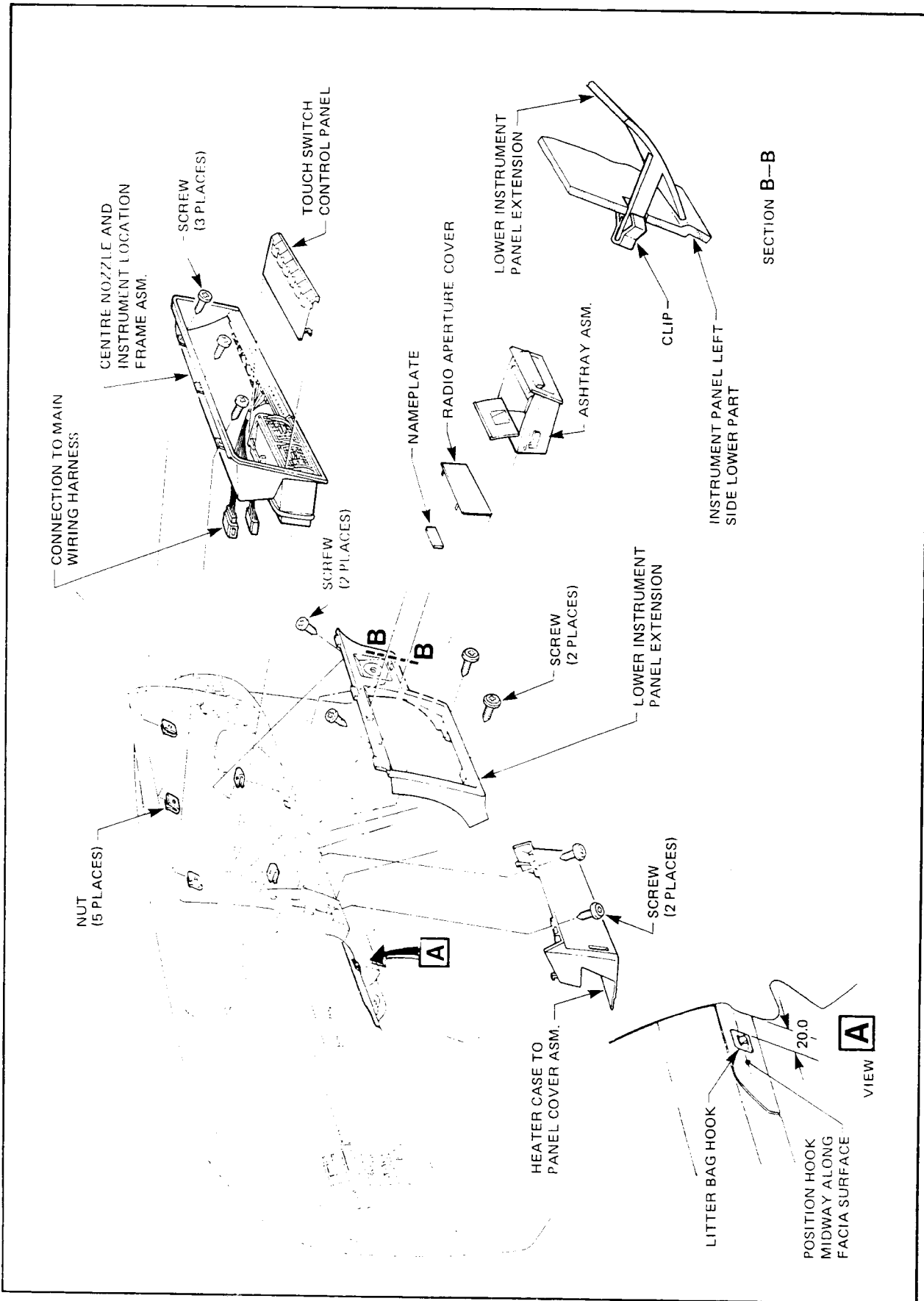

Figure 2A-9

1.5 BLOWER MOTOR

REMOVE

1. Disconnect battery earth cable.
2. From under the left hand side of instrument panel and using a fabricated trim clip removal tool (refer 10 Special Tools at the end of Section 2B) remove the left hand instrument panel lower trim (refer Fig. 2A-10).

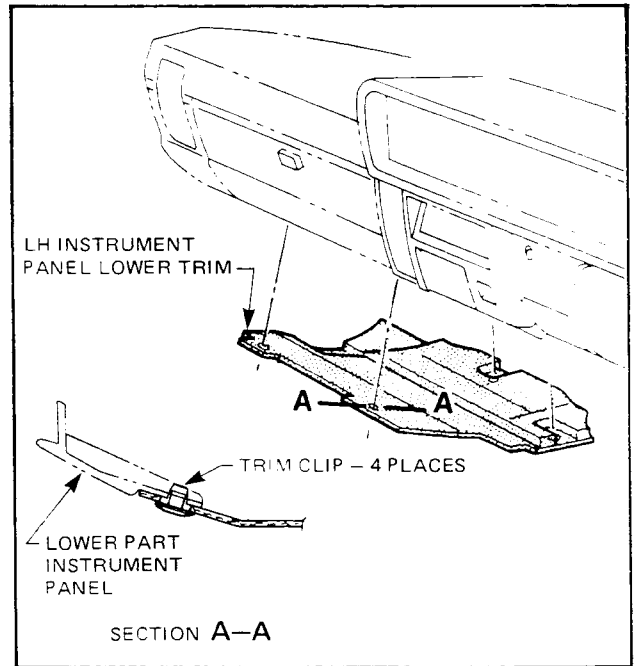

Figure 2A-10

3. From under the instrument panel, disengage the blower motor to main wiring harness connector, then supporting the blower motor, remove the two screws securing the motor to the blower housing illustrated in Fig. 2A-11, removing the motor.

REINSTALL

Reverse removal procedures.

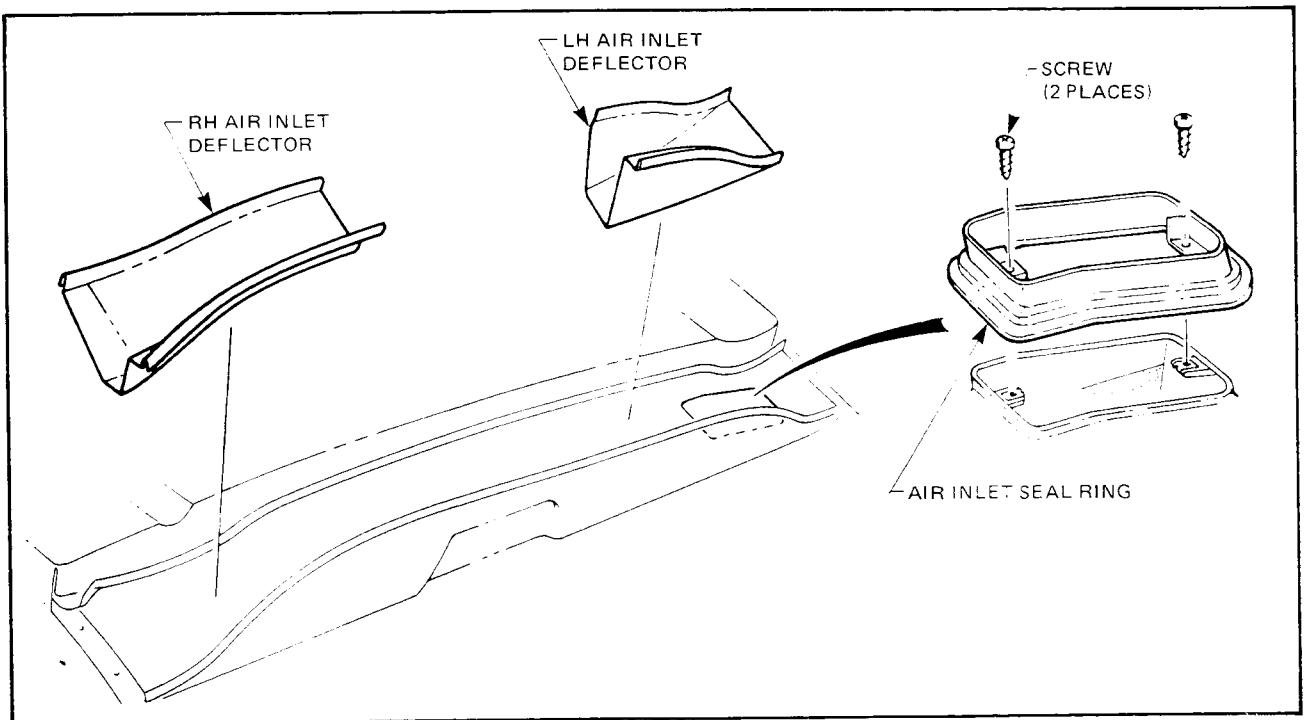

Figure 2A-11

2A-10 VENTILATION & HEATING

1.6 BLOWER MOTOR HOUSING ASSEMBLY

REMOVE

1. Disconnect battery earth cable and blower motor to main wiring harness connector.
2. From under left hand of instrument panel and using a fabricated trim clip removal tool (refer 10 Special Tools at the end of Section 2B) remove the instrument panel lower trim (refer Fig. 2A-10).
3. From inside the engine compartment, remove the left hand air inlet deflector and the screw attached air inlet seal ring secured to the left hand side of the plenum chamber, as illustrated in Fig. 2A-11. Remove the ring assembly.
4. With the instrument panel compartment open and with the blade of a screddriver located between the head of the hinge pin and the right hand compartment side, prise the hinge pin into the compartment as illustrated in Fig. 2A-12, then remove the compartment.
5. Remove the blower motor housing to heater assembly duct illustrated in Fig. 2A-13.
6. From the base of blower motor housing, remove bolt securing lower part of housing to left hand dash panel lower, illustrated in Fig. 2A-13.
7. Remove the nuts securing the blower motor housing to the studs attached to the left hand side of the plenum chamber illustrated in Fig. 2A-13, removing the housing assembly.

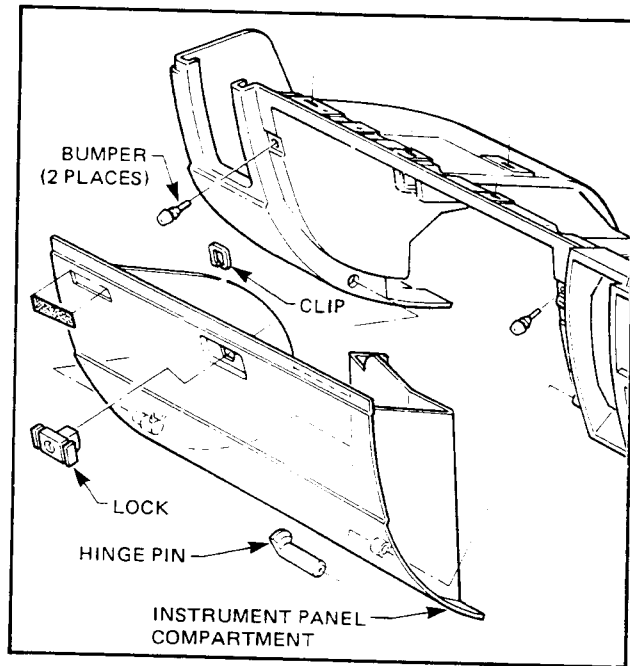

Figure 2A-12

REINSTALL

Reverse removal procedures.

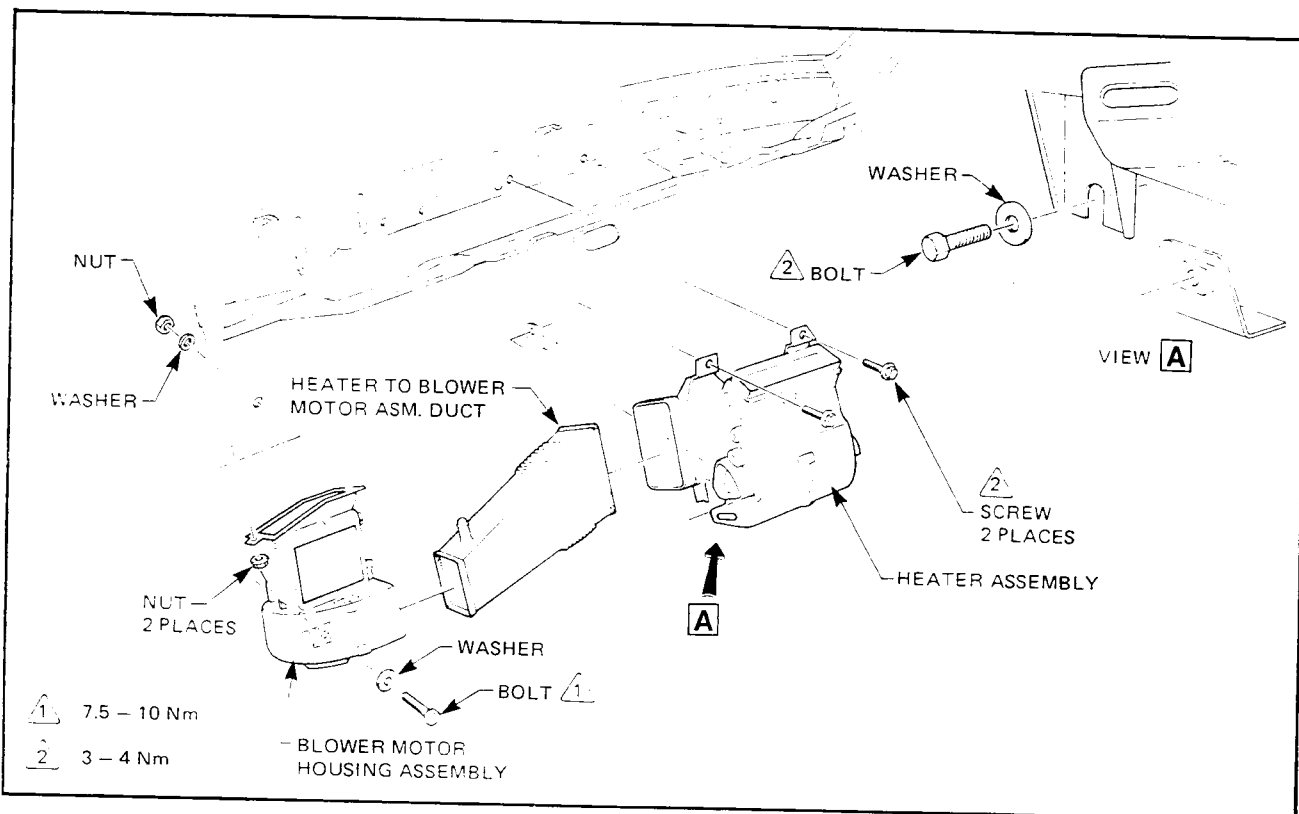

Figure 2A-13

1.7 HEATER ASSEMBLY

REMOVE

1. Disconnect the battery earth cable.
2. Disconnect the vacuum feed hose at the check valve then from inside the engine compartment, remove the rubber grommet from the dash and the coolant hoses from the inlet and outlet heater core pipes illustrated in Fig. 2A-14.

CAUTION: The heater can easily be damaged in the area of the core tube attachment seams whenever undue force is exerted on them. When the heater hoses do not readily come off the tubes, the hoses should be cut just forward of the core tubes. The portion of the hose remaining on the tube should then be split longitudinally. Once the hoses have been split, they can be removed from the tubes without causing damage to the core.

3. Remove the instrument panel lower (refer 3.4 in Section 1A, Body Section).
4. Remove heat/vent control assembly from instrument panel (refer Fig. 2A-8).
5. Remove the blower motor housing to heater assembly duct illustrated in Fig. 2A-13.
6. Remove the ends of the ducting attached to the heater assembly illustrated in Fig. 2A-15.
7. Remove the bolt securing the lower part of the heater assembly to the floor pan bracket, as illustrated in View A Fig. 2A-13.
8. Remove the two bolts securing the top of the heater assembly to the instrument panel brace as illustrated in Fig. 2A-13, then remove the heater assembly.

REINSTALL

Reverse removal procedures, ensuring that the heater core pipe grommet is correctly installed to fully seal the hole in the lower dash panel. Also check that the electricals and ducting disturbed during the removal procedures are operating effectively.

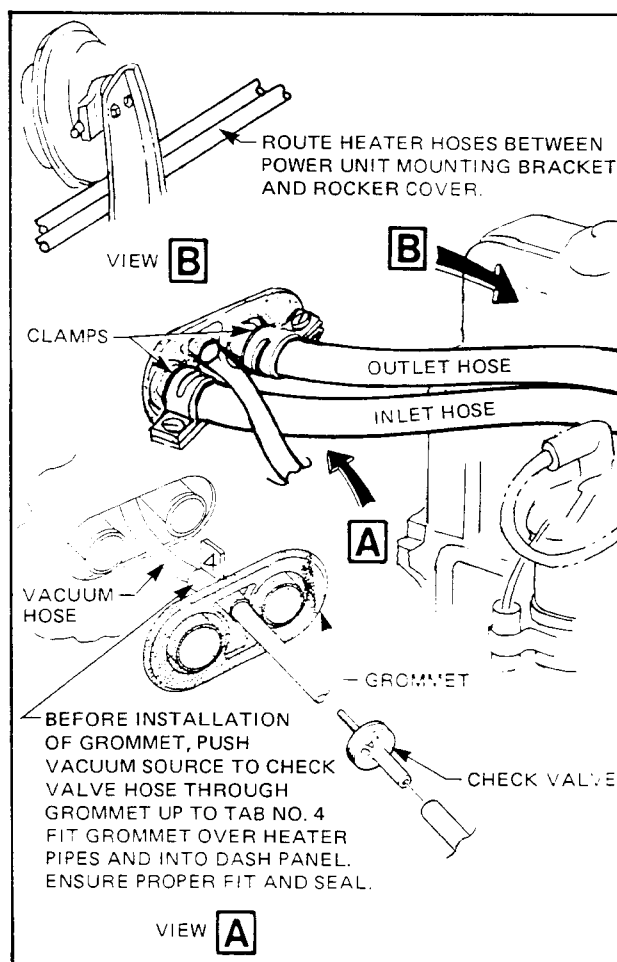

Figure 2A-14

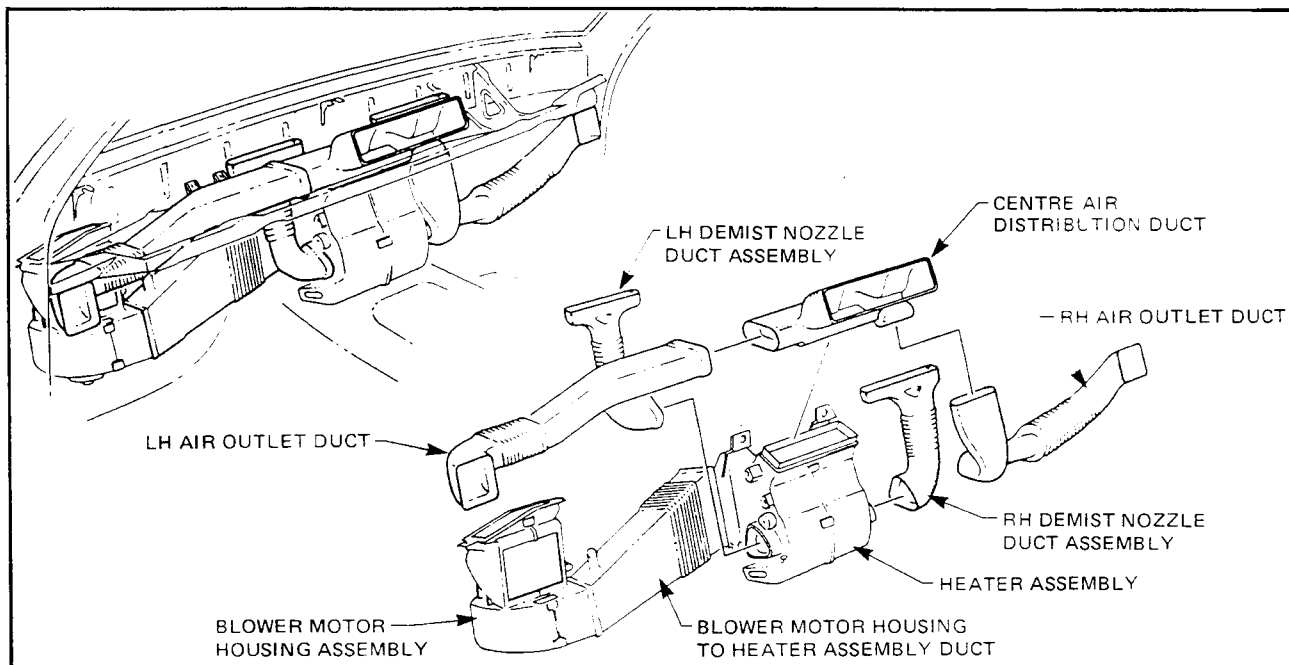

Figure 2A-15

2A-12 VENTILATION & HEATING

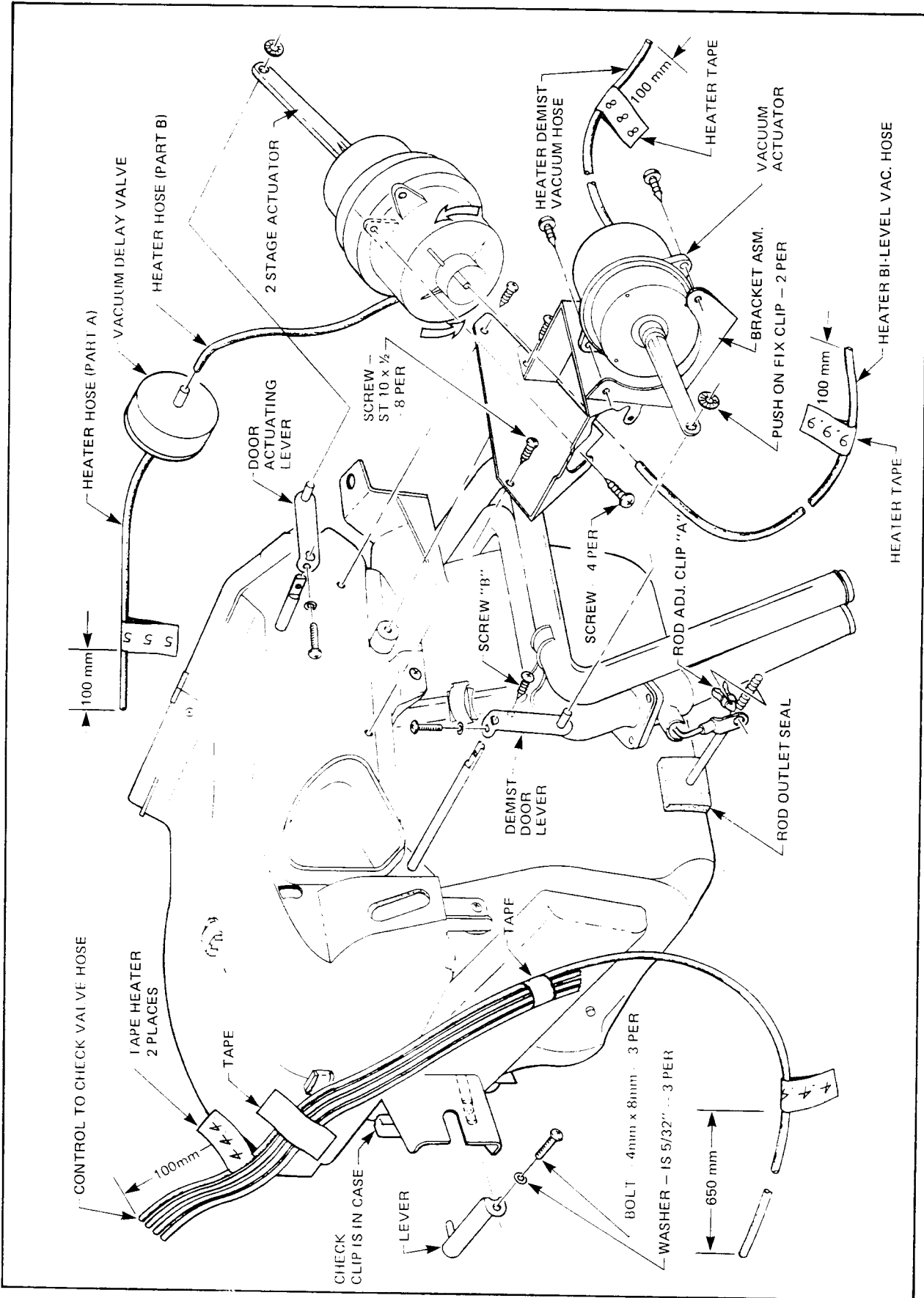

Figure 2A-16

1.8 HEATER CORE AND PIPE ASSEMBLY

REMOVE

1. Remove the heater assembly as previously described.
2. With the right hand side of the heater assembly uppermost, disconnect door rod adjusting retainer clip 'A', then remove screw 'B', both illustrated in Fig. 2A-16.
3. With the heater assembly in the upright position, remove the screw attached bracket 'A' illustrated in Fig. 2A-17, then slide out the core and pipe assembly from the heater case.

REINSTALL

Reverse removal procedures.

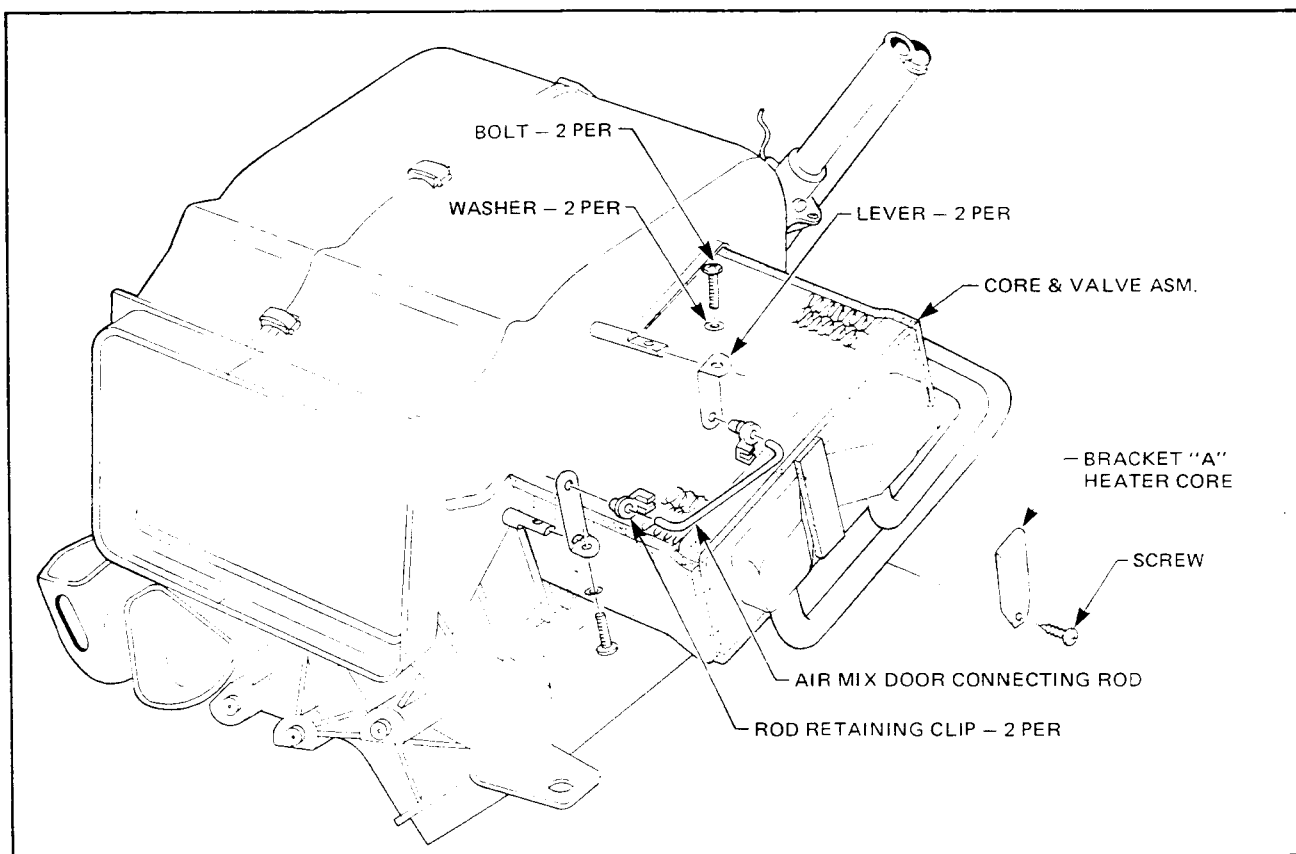

Figure 2A-17

2A-14 VENTILATION & HEATING

1.9 WATER VALVE ASSEMBLY - HEATER CORE

REMOVE

1. From inside the engine compartment, remove the heater core hoses illustrated in Fig. 2A-14.

CAUTION: The heater can easily be damaged in the area of the core tube attachment seams whenever undue force is exerted on them. When the heater hoses do not readily come off the tubes, the hoses should be cut just forward of the core tubes. The portion of the hose remaining on the tube should then be split longitudinally. Once the hoses have been split, they can be removed from the tubes without causing damage to the core.

2. Remove the rubber grommet sealing the heater core pipes passing through the lower dash panel.
3. Using a cross recess headed screwdriver located inside of the dash inner panel hole adjacent to the heater core outlet pipe, remove the four screws securing the water valve assembly to the heater core pipe illustrated in Fig. 2A-18, then remove the valve assembly, taking care not to loose the 'O' ring located between the valve and heater core outlet pipe.

REINSTALL

Reverse removal procedures.

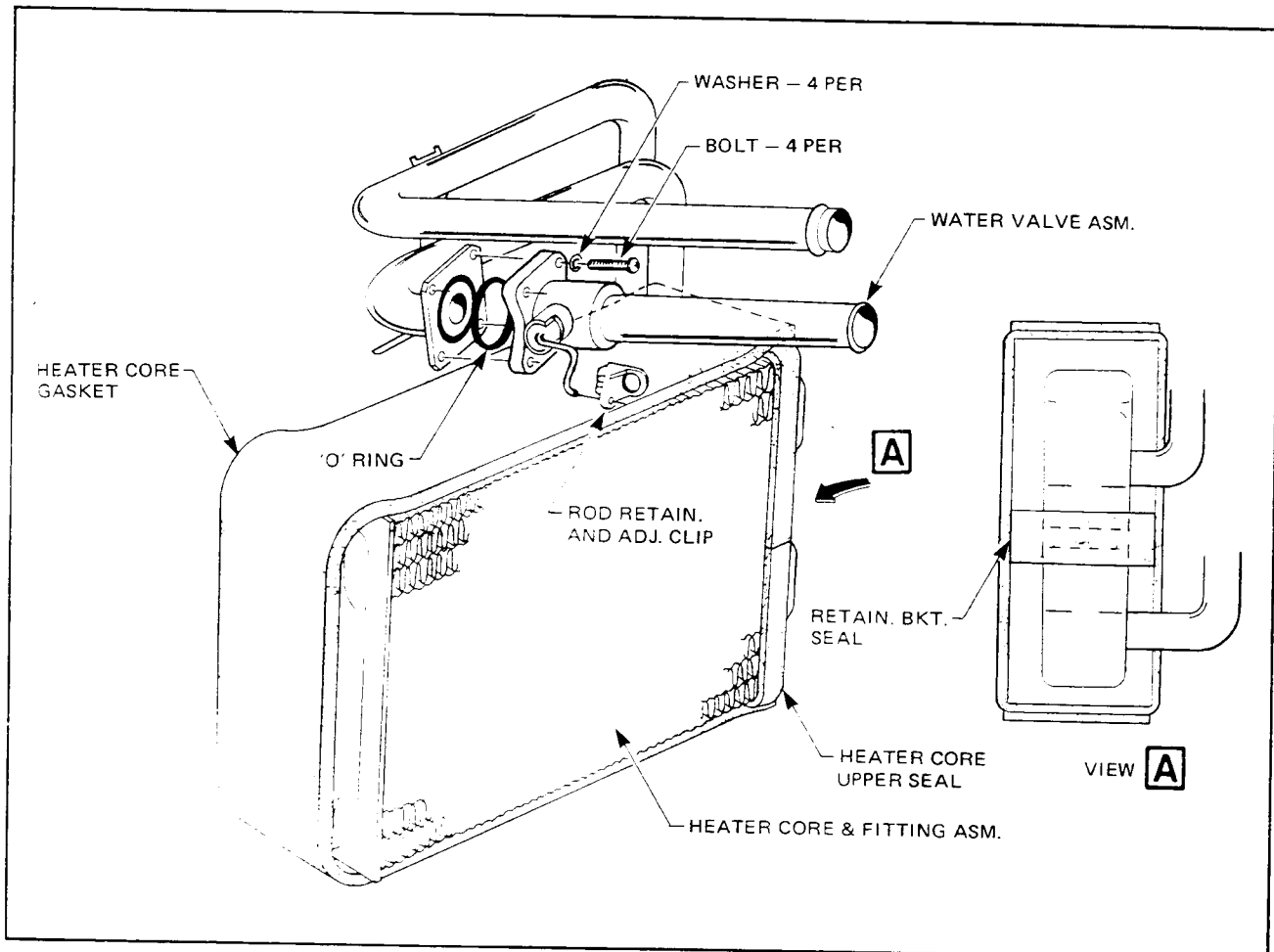

Figure 2A-18

SECTION 2B

AIR CONDITIONING

INDEX

Ref.	Subject	Page	Ref.	Subject	Page
1.	GENERAL INFORMATION	2B-1	3.4	COMPRESSOR INSPECTION PROCEDURES.....	2B-14
2.	GENERAL DESCRIPTION	2B-3		Leak Test	2B-14
2.1	MANUAL CONTROLS	2B-3		Compressor Smoothness Test.....	2B-14
	'DEM'	2B-3		Clutch Test	2B-14
	'FLOOR'	2B-3		Noise	2B-14
	'VENT'	2B-3		Remove	2B-16
	'BI LEVEL'	2B-4		Reinstall	2B-16
	'NORM'	2B-4		Disassembly	2B-16
	'MAX'	2B-4		Reassembly	2B-18
	'OFF'	2B-4		Air Gap Adjustment.....	2B-20
	Refrigerant Circuit	2B-5	3.5	EVAPORATOR ASSEMBLY	2B-20
	Compressor	2B-8		Remove.....	2B-20
	Thermostatic Switch	2B-9		Reinstall	2B-25
	Evaporator	2B-9	3.6	EVAPORATOR CORE AND PIPE ASSEMBLY	2B-27
	Thermostatic Expansion Valve.....	2B-9		Remove.....	2B-27
	Receiver Dehydrator	2B-9		Reinstall	2B-27
	Condenser	2B-9	3.7	CONDENSOR AND AUXILIARY FAN ASSEMBLY	2B-27
3.	SERVICE OPERATIONS	2B-11		Remove.....	2B-27
3.1	COMPRESSOR DRIVE BELT TENSION AND ADJUSTMENT	2B-11		Reinstall	2B-27
3.2	CHECKING COMPRESSOR OIL CHARGE ON VEHICLE	2B-11	3.8	AUXILIARY FAN	2B-27
	Adding Oil During Component Replacement	2B-11		Remove.....	2B-27
	Compressor	2B-11		Reinstall	2B-27
	Reinstalling the Original Compressor	2B-11	3.9	RECEIVER DEHYDRATOR	2B-29
	Installing a New Compressor ..	2B-11		Remove.....	2B-29
	Evaporator	2B-11		Reinstall	2B-29
	Condenser	2B-11	4.	DIAGNOSIS CHART	2B-30
	Receiver Dehydrator	2B-11	5.	SPECIAL TOOLS	2B-32
3.3	REFRIGERANT SYSTEM CHARGING	2B-12			
	Filling Charging Cylinder	2B-12			
	Installation of Charging Station	2B-12			
	Charging System	2B-13			
	Evacuation and Leak Test	2B-13			
	Purging (If Necessary)	2B-13			
	Charging System	2B-13			
	Functional Testing of System..	2B-13			

1. GENERAL INFORMATION

The Air International air conditioning system used on VK models is a cycling clutch system with thermostatic expansion valve (C.C.T.X.V.) and a Sanden TR 70 Spiral Compressor.

The following information provides basic service operations for the C.C.T.X.V. air conditioning system, including the TR 70 Spiral Compressor.

2B-2 AIR CONDITIONING

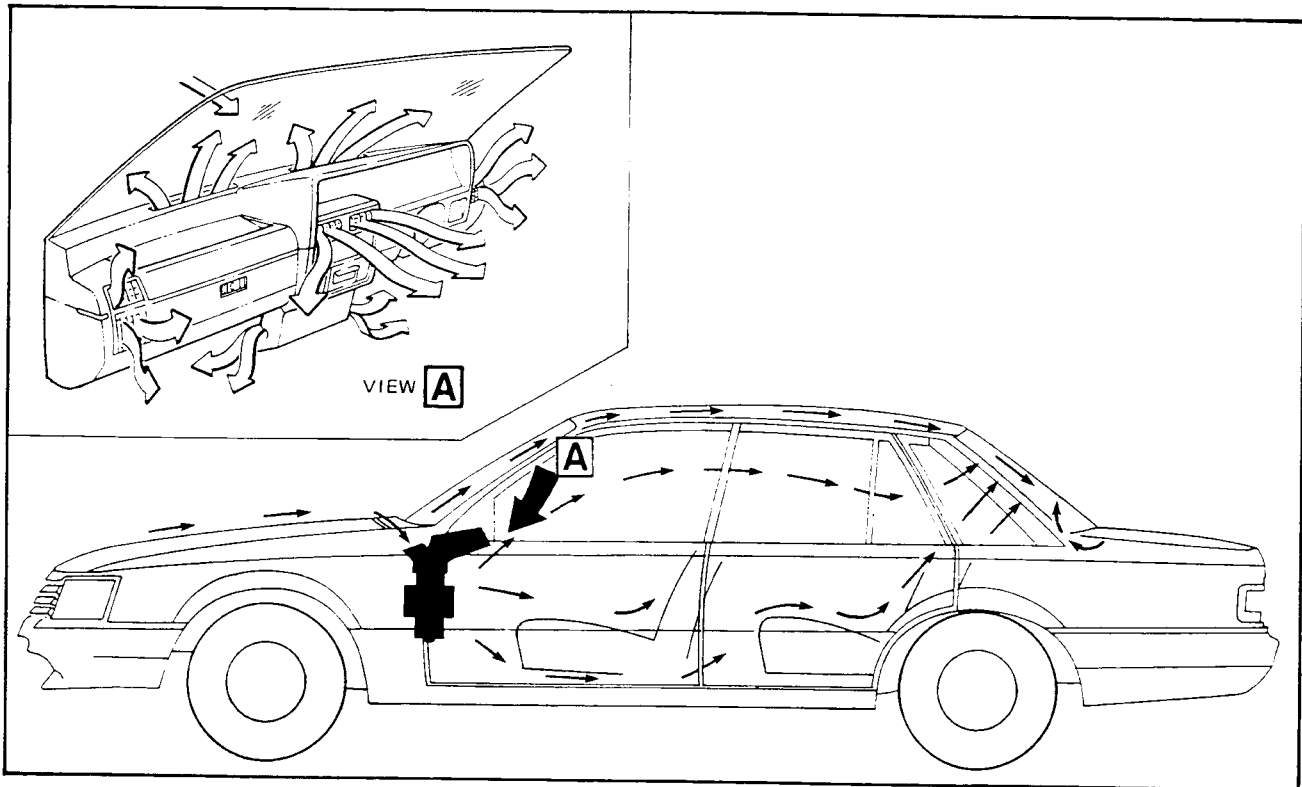

Figure 2B-1

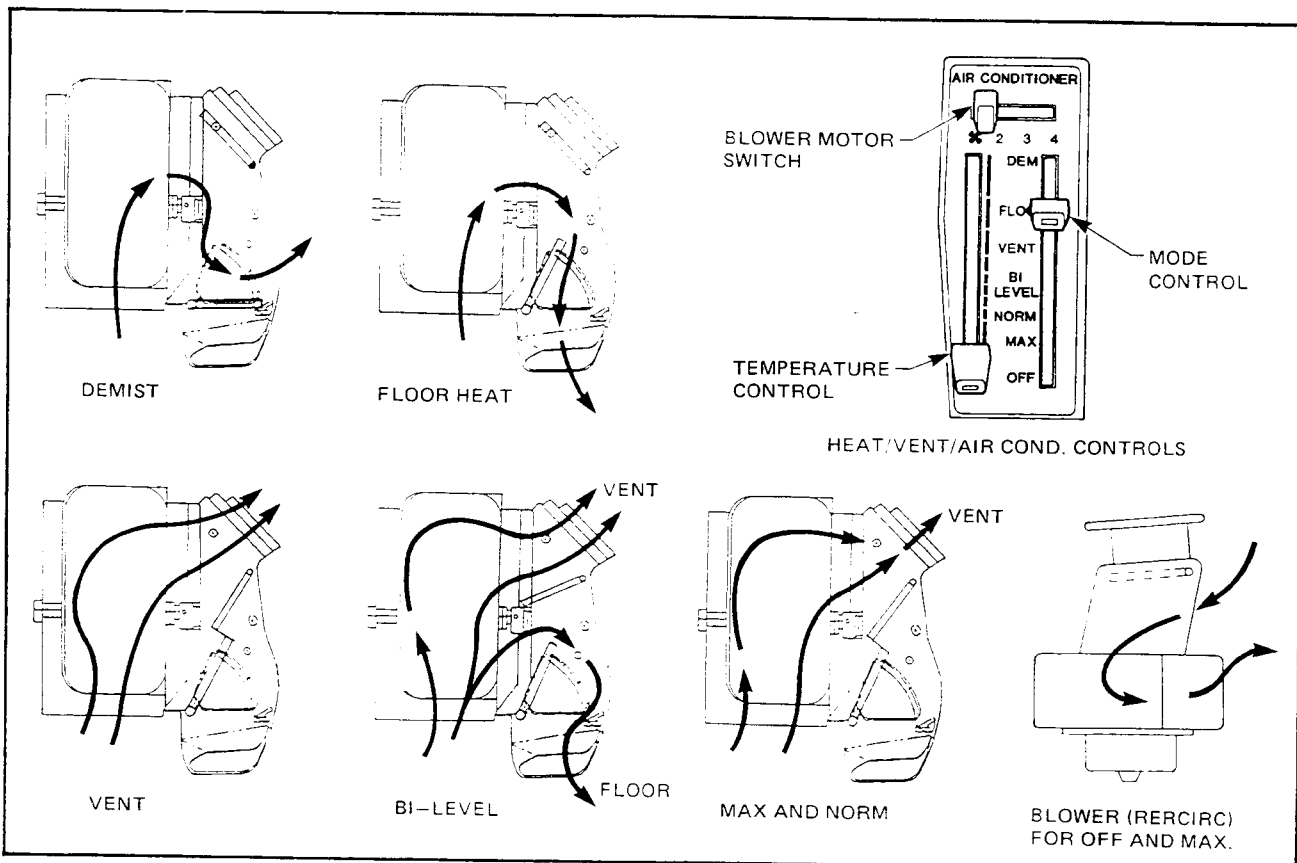

Figure 2B-2

2. GENERAL DESCRIPTION

The VK cycling clutch and thermostatic expansion valve (C.C.T.X.V.) air conditioning system permits cooled, heated, mixed or ambient air to flow through the vehicle, depending on the position of the mode and temperature control levers.

Air entering the air conditioning/heating system via the grille at the rear of the engine hood, passes through the blower motor housing and evaporator and heater assemblies, to be cooled or heated as required, then enters the passenger compartment through the centre and/or side upper ventilator outlets, or through the demist or footwell outlets (refer Fig. 2B-1) depending on the position of the mode or temperature control levers illustrated in Fig. 2B-2. Fig. 2B-2 also illustrates the air flow within the system with the various modes activated.

A four speed high capacity blower fan forces air from the plenum chamber, through the evaporator and heater assemblies, then out through the various outlets into the passenger compartment.

NOTE: The blower motor is automatically switched on to low speed whenever the mode control lever is moved from 'OFF' position.

On Sedans, air from the passenger compartment exhausts through the ventilator outlets located behind the right and left hand side rear drip moulding assemblies, illustrated in Fig. 2B-3.

On station wagons, the air is exhausted via the edges of the rear quarter inner trim panels, into the roof, then out into the atmosphere through the tailgate hinge pockets.

The controls illustrated in Fig. 2B-2, consist of a four speed fan switch and two sliding levers. The left hand lever regulates the temperature of the air entering the vehicle in all modes and the right hand lever enables selection of the particular mode required. The mode lever has seven positions.

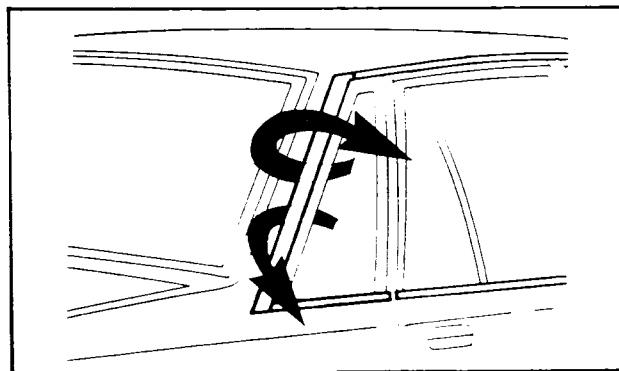

Figure 2B-3

2.1 MANUAL CONTROLS

'DEM'

In this position, the air flows mainly onto the windscreen through demist vents on top of the instrument panel. A small amount of air goes to the floor outlets. The air is cooled to reduce humidity and then can be reheated to the setting required to demist the windscreen.

'FLOOR'

In this position, the main air flow is directed to the floor outlets with a small amount of air going to the demist vents. The air conditioning compressor does **not** operate in this mode.

'VENT'

This setting directs all air to the centre and side vents. The air flow and direction can be adjusted at each vent by directional vanes and thumb wheels. The air can also be shut off individually at these vents to achieve the desired comfort. The air conditioning compressor does **not** operate in this mode.

2B-4 AIR CONDITIONING

'BI LEVEL'

This position directs the air both to the centre and side vents as well as to the floor outlets. When using BI LEVEL with the temperature lever in an intermediate position, warm air will be directed to the feet and cooled air to the face (centre and side vents).

Cooled air is available to both foot and face levels when the temperature lever is positioned at cold.

'NORM'

This setting directs outside air through the centre and side vents, used for most cooling needs on hot days. The air is cooled to reduce humidity and remove dust and pollen etc. It can then be reheated if required to a temperature determined by the temperature control lever.

'MAX'

Use for maximum cooling or quick cool down on very hot days. On this setting the cabin air is recirculated through the air conditioning system. No outside air is admitted through the inlet grille and therefore the driver should return to NORMAL setting once interior temperature has reached an acceptable level.

This mode is also used to exclude unwanted dust or fumes from entering the system.

'OFF'

On this setting the fan is switched off and the door is closed so that no outside air is admitted and the air conditioning compressor does not operate.

NOTE: The fan automatically switches on to its lowest speed when the mode lever is moved away from OFF position. Fan speed can then be increased by selecting a higher number.

1. Outside air is used in all modes except MAX and OFF. Do not operate in MAX or OFF for long periods as no outside air is admitted to the vehicle.
2. When driving in very dusty conditions, i.e. following another vehicle, use 'MAX' or 'OFF' mode depending on whether you require the air conditioner on or off respectively. Through door and window seals either setting will prevent outside air from entering until driving conditions permit return to one of the other settings. Selection of 'NORM' A/C with high blower speeds and all windows closed, will pressurize the interior of the vehicle, excluding dust entry.
3. Under most conditions it is recommended that 'MAX' (recirculated air) setting be avoided if occupants are smoking as residues from the tobacco smoke adhere to the evaporator and air ducts and will result in stale smelling air inside the vehicle.
4. **Automatic Transmission**
If your vehicle is stopped for long periods in hot weather with the engine running and air conditioner operating, select 'NEUTRAL' or 'PARK'. This will increase your engine speed which in turn aids engine cooling and air conditioner performance.
5. 'OFF' you should only use this setting with the windows open.
6. The following procedure should be carried out regularly during those periods of the year (e.g. winter) when the air conditioning modes may not normally be used.

Once every two weeks, with the engine running, switch the air conditioner on by selecting either 'DEM', 'BI LEVEL', 'NORM' or 'MAX' mode. The unit should be run for at least 5-10 minutes.

This procedure recirculates the oil within the compressor and lubricates compressor shaft seals. This will help to prevent the drying out of the seals with subsequent operating failure of the system.

- The air conditioner operates most efficiently with all windows closed. However, to speed up the cooling of the car interior on very hot days, it is recommended that the windows should be opened for the first minute to allow the hot air to escape.

REFRIGERANT CIRCUIT

The refrigerant circuit illustrated in Fig. 2B-4 incorporates the following major components:

A compressor, thermostatic switch, evaporator, thermostatic expansion valve, receiver dehydrator and a condenser.

Figs. 2B-5, 2B-6 and 2B-7 illustrate refrigerant tube and hose routing and connections.

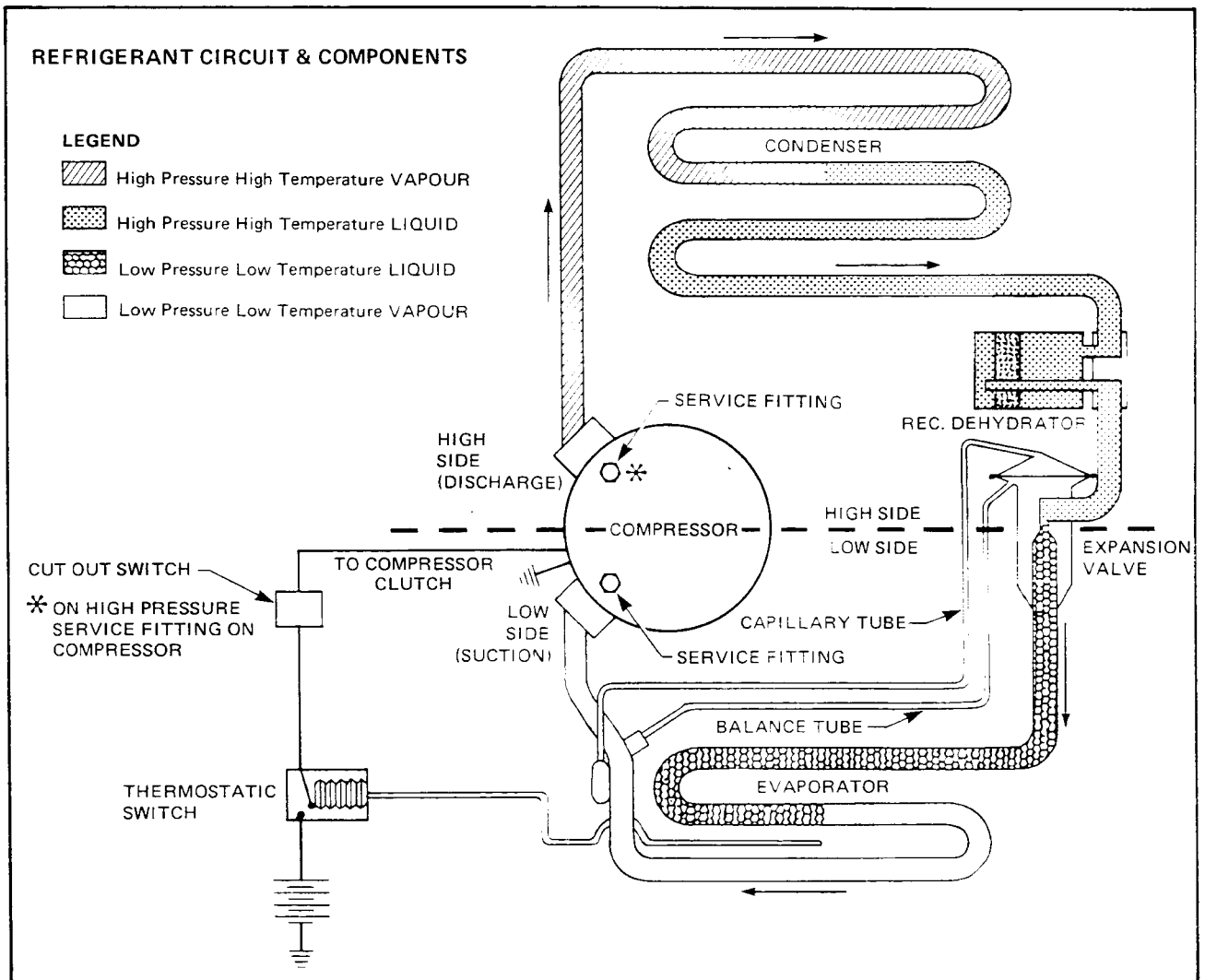

Figure 2B-4

2B-6 AIR CONDITIONING

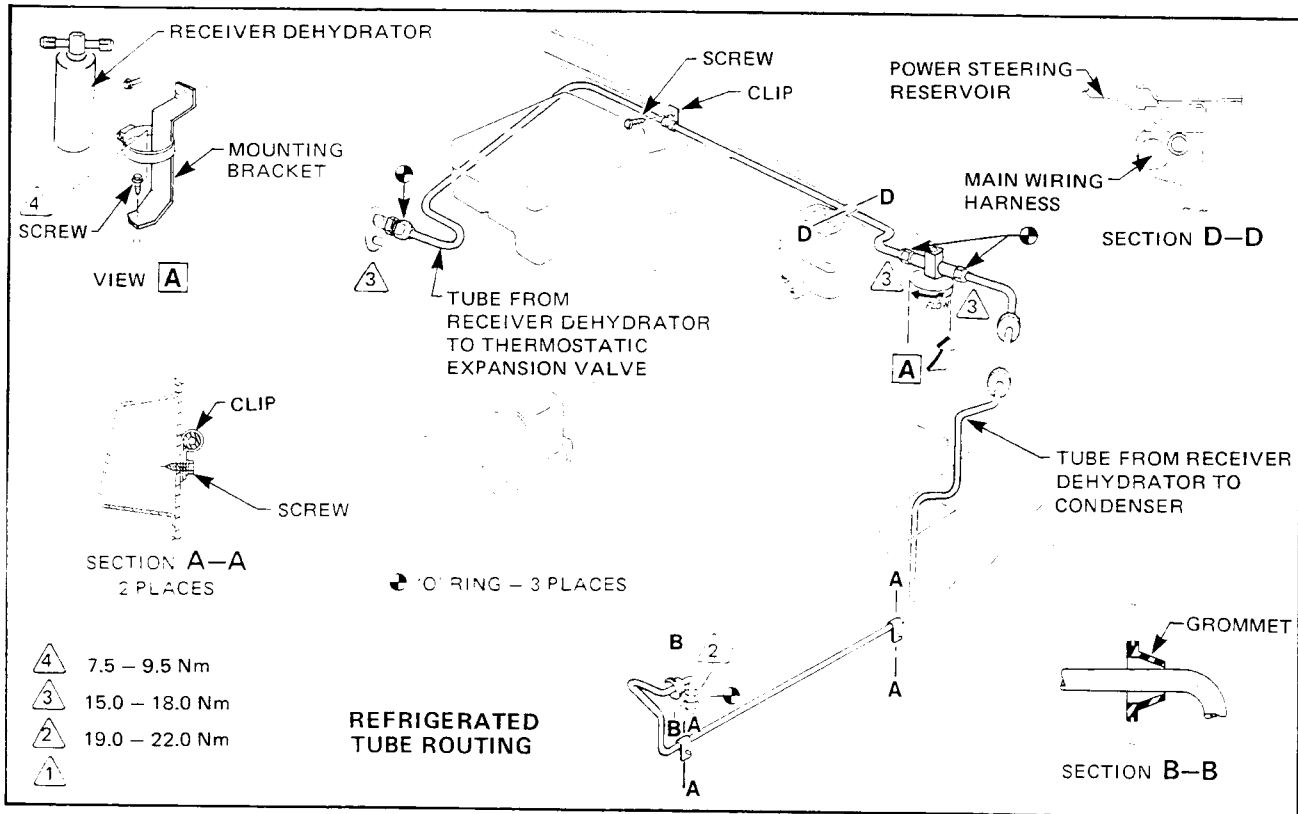

Figure 2B-5

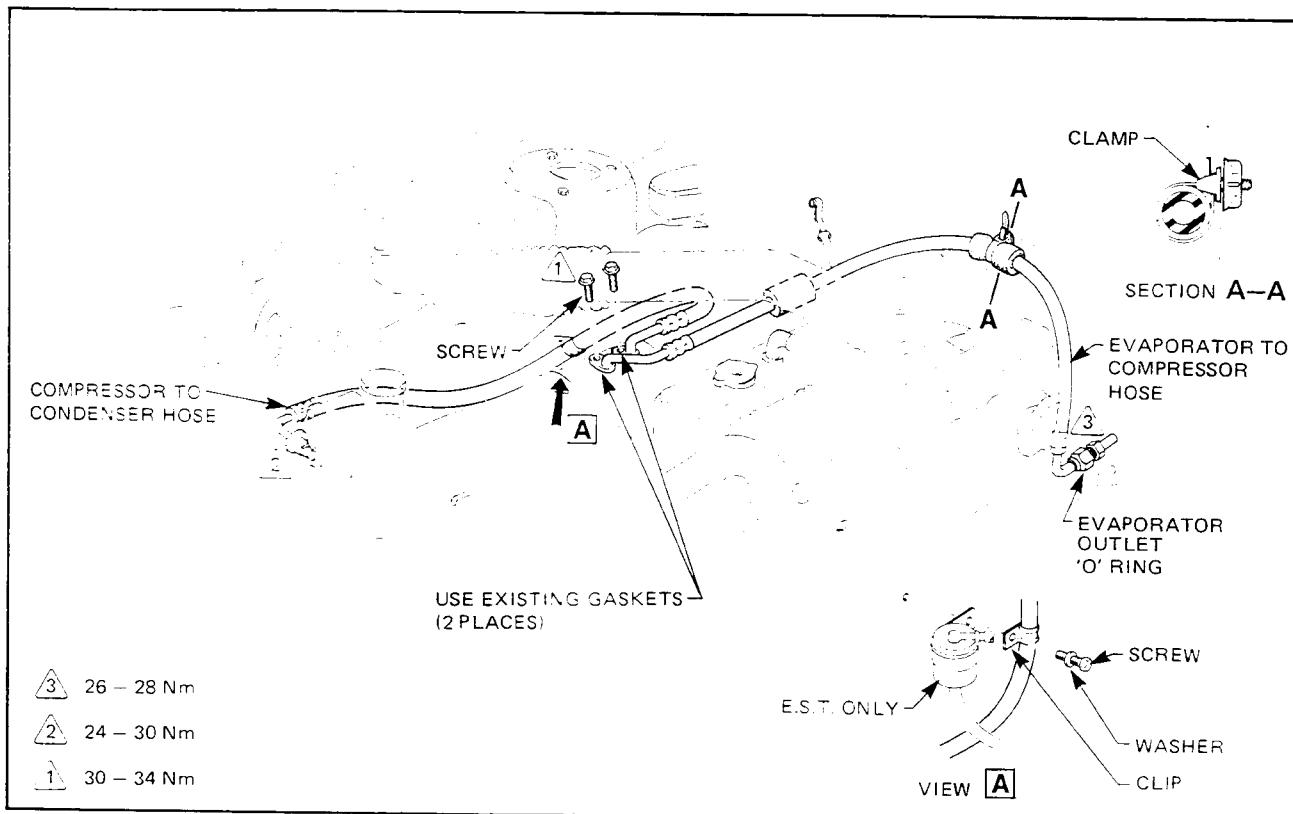

Figure 2B-6

2B-8 AIR CONDITIONING

COMPRESSOR

The compressor fitted to VK models illustrated in cut away section in Fig. 2B-8 is the TR 70 manufactured by Sanden. It is a new design based on a gyrating spiral within a spiral principle.

Two spiral components have 2.8 turn involute spiral walls projected from discs. Both spiral components are housed in a cylindrical casing, with one in a fixed position and the other interleaved with the former at an angular relationship of 180° . The free moving components are driven by a crankshaft in an orbiting motion. The orbiting motion of the free moving component provides a continuous compression process in two pairs of compression pockets.

The compressor is belt driven from the engine crankshaft through an electro magnetic clutch. In the cycling clutch system, the compressor is run intermittently, automatically turning on and off in response to an electric signal controlled by the thermostatic switch. The compressor will cycle as necessary to maintain minimum temperature without the evaporator core freezing.

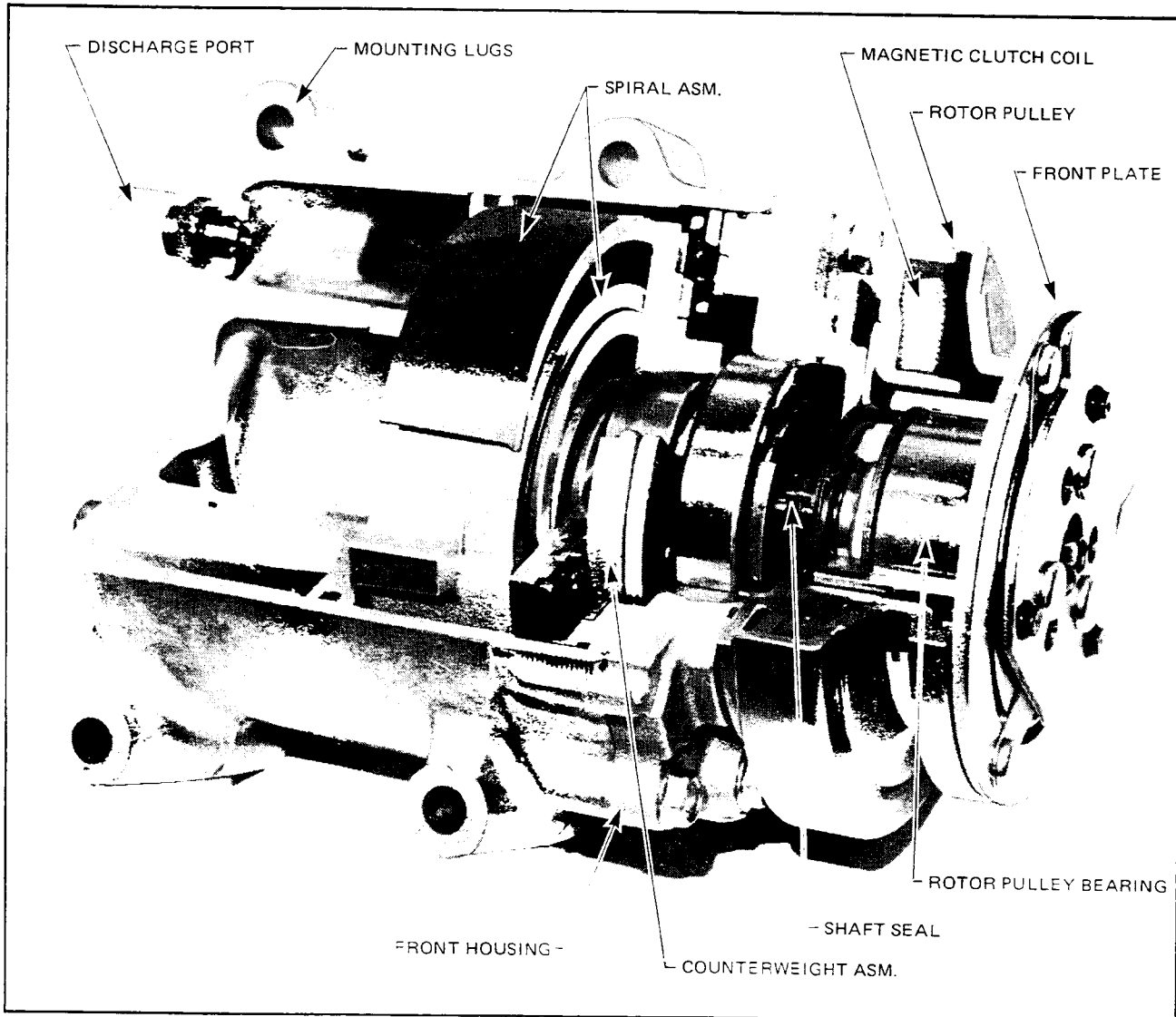

Figure 2B-8

THERMOSTATIC SWITCH

The switch, through a capillary tube, 'senses' variations in the temperature of the evaporator core and, by making or breaking the electrical circuit to the compressor clutch coil, causes the clutch to engage and disengage, thus keeping the evaporator core just above freezing.

EVAPORATOR

The evaporator assembly located under the instrument panel and adjacent to the instrument panel compartment, cools and dehumidifies the air before it enters the passenger compartment of the car.

THERMOSTATIC EXPANSION VALVE

The thermostatic expansion valve regulates the supply of liquid refrigerant to the evaporator.

IMPORTANT: No attempt should be made to adjust this valve or damage to the compressor may occur.

RECEIVER DEHYDRATOR

The receiver dehydrator serves as a reservoir for storage of high pressure liquid produced in the condenser and incorporates a screen sack filled with dessicant to absorb traces of moisture.

A sight glass built into the top of the receiver dehydrator (refer Fig. 2B-5) enables a quick check of the amount of refrigerant charge in the system. If the refrigerant charge is low, a persistent frothing condition will be visible at this sight glass. To overcome this condition, refer to the Diagnostic Chart at the end of this Section.

CONDENSER

The condenser is mounted forward of the engine radiator and is therefore exposed to a flow of ram air from the movement of the vehicle and from the engine fan. The purpose of the condenser is to convert the high pressure, high temperature refrigerant gas discharged by the compressor into high pressure liquid refrigerant. An auxiliary electric cooling fan is centrally mounted directly in front of the condenser.

The system carries 1050 g of R12 refrigerant and 150 cc of Suniso No. 5GS refrigerant oil.

2B-10 AIR CONDITIONING

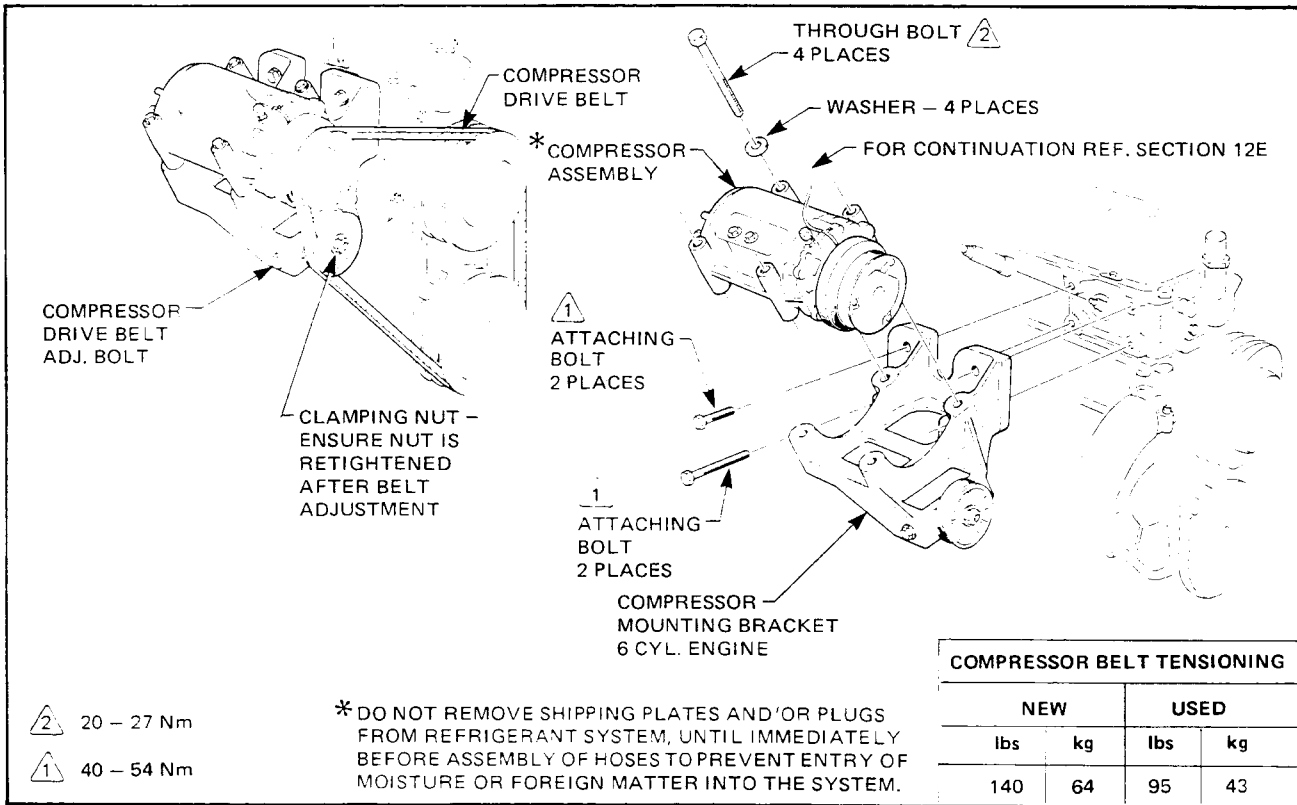

Figure 2B-9

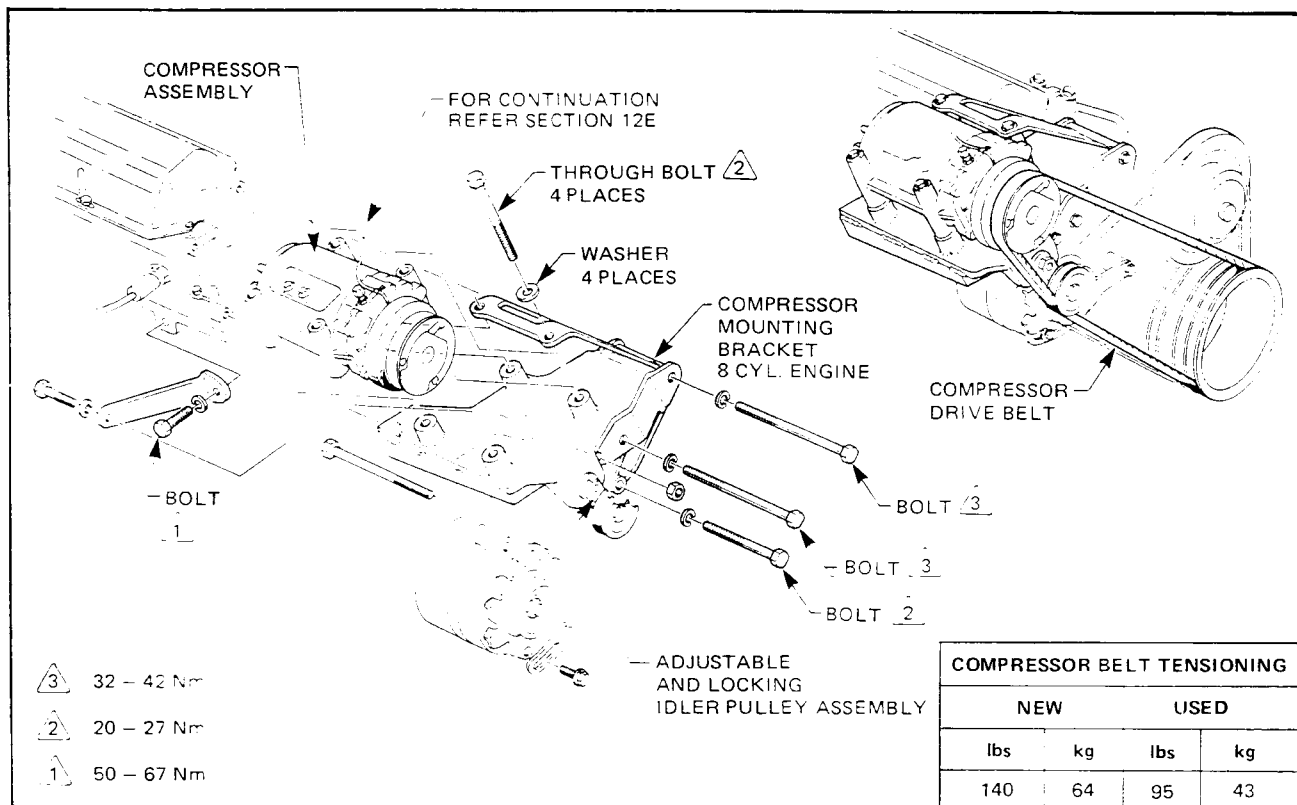

Figure 2B-10

3. SERVICE OPERATIONS

3.1 COMPRESSOR DRIVE BELT TENSION AND ADJUSTMENT

Adjust the compressor drive belt using belt tension dial gauge 982350 or equivalent.

On 6 Cylinder Engines:

Before adjusting the compressor drive belt bolt (refer Fig. 2B-9), slacken off the idler pulley clamping nut. On completion of belt adjustment, torque clamping nut to 40 - 50 Nm.

On 8 Cylinder Engines:

Slacken off the idler pulley arm/clamping nut assembly (refer Fig. 2B-10), adjust compressor drive belt tension, then torque clamping nut assembly to 40 - 50 Nm.

At the time of initial installation of a new belt only, the strand tension should be 64 kg (140 lbs) plus or minus 2.25 kg (5 lbs) but after ten minutes 'run-in' or with used belts, a value of 43 kg (95 lbs) plus or minus 2.25 kg (5 lbs) applies.

3.2 CHECKING COMPRESSOR OIL CHARGE ON VEHICLE

The compressor is charged at the factory with 150 cc of Suniso No. 5GS refrigerant oil. Only this type of oil should be used when adding or changing oil.

It is not necessary to regularly check the oil level in the compressor. In general, the compressor oil level should only be checked in cases where a major loss of system oil has occurred, such as:-

- a. A broken hose or severe leak.
 - b. Collision damage to refrigerant system components.
 - c. If excess oil is suspected to be in the system.
1. Discharge refrigerant from system, then remove the compressor.
 2. Remove discharge port cap of the compressor then carefully drain and measure the refrigerant oil.
 3. Flush oil from rest of system using R12 gas.
 4. Add 150 cc of new refrigerant oil to the compressor.
 5. Install the discharge port cap after first ensuring that the seal 'O' ring is not twisted and that the seat and 'O' ring are clean. Tighten the cap to 8-12 Nm torque.
 6. Evacuate then recharge system.

NOTE: Never over tighten the discharge port cap to overcome a refrigerant leak. Remove the cap and replace the 'O' ring.

ADDING OIL DURING COMPONENT REPLACEMENT

Some oil is lost whenever air conditioning system components are replaced.

Where the system has been ruptured, a leak has occurred or a compressor has to be removed and reinstalled or replaced, the entire system must be flushed with R12 gas.

IMPORTANT: The complete air conditioning system must contain 150 cc of refrigerant oil to function correctly.

NOTE: A new compressor will contain 150 cc of factory installed refrigerant oil.

If there are no signs of excessive refrigerant oil loss, add the following amount of oil depending on the component being replaced.

COMPRESSOR

Reinstalling the Original Compressor

1. Drain and measure the refrigerant oil contained in the compressor.
2. Replace the oil in the compressor with the same amount of new refrigerant oil.

Installing a New Compressor

1. Drain and measure refrigerant oil from original compressor.
2. Drain factory installed refrigerant oil from new compressor.
3. Measure the same amount of new refrigerant oil that was drained from the original compressor and install this amount of oil into the new compressor.

EVAPORATOR

Drain as much of the original oil as possible from the evaporator, then add the same amount of new refrigerant oil, either to the original or new evaporator.

CONDENSER

Drain as much of the original oil as possible from the condenser, then add the same amount of new refrigerant oil, either to the original or new condenser.

RECEIVER DEHYDRATOR

Drain as much of the original oil as possible from the receiver dehydrator, then add the same amount of new refrigerant oil, either to the original or new receiver dehydrator.

NOTE: If the condenser, evaporator or the receiver dehydrator contains more than 25 cc of refrigerant oil, or the compressor more than 150 cc of refrigerant oil, then it must be assumed that the system contains excess oil. This condition necessitates complete flushing of the whole system with R12 gas and 150 cc of new refrigerant oil added to the compressor.

2B-12 AIR CONDITIONING

3.3 REFRIGERANT SYSTEM CHARGING

The following procedures are accomplished by using the manifold gauge set illustrated in Fig. 2B-11, which allows the rate of refrigerant discharge to be controlled, thus minimizing loss of compressor oil from the system.

CAUTION: The wearing of safety goggles is mandatory during system charging.

Filling Charging Cylinder

1. Open valve on bottom of charging cylinder allowing refrigerant to enter cylinder.
2. Bleed cylinder via valve on top (behind control panel) as required to allow refrigerant to enter. It will be necessary to close bleed valve periodically to allow boiling to subside to check level in sight glass. When refrigerant reaches desired level, close valve at bottom of cylinder and be certain bleed valve is closed securely.

Installation of Charging Station

1. Close all valves on charging station.
2. Remove cut-out switch from high pressure charging port, disconnect switch leads from compressor and main wiring harness, then reconnect main wiring harness direct to compressor.
3. Connect high pressure and low pressure lines to the gauge set fittings on the compressor.
4. Connect vacuum pump line and charging cylinder hose to gauge set.

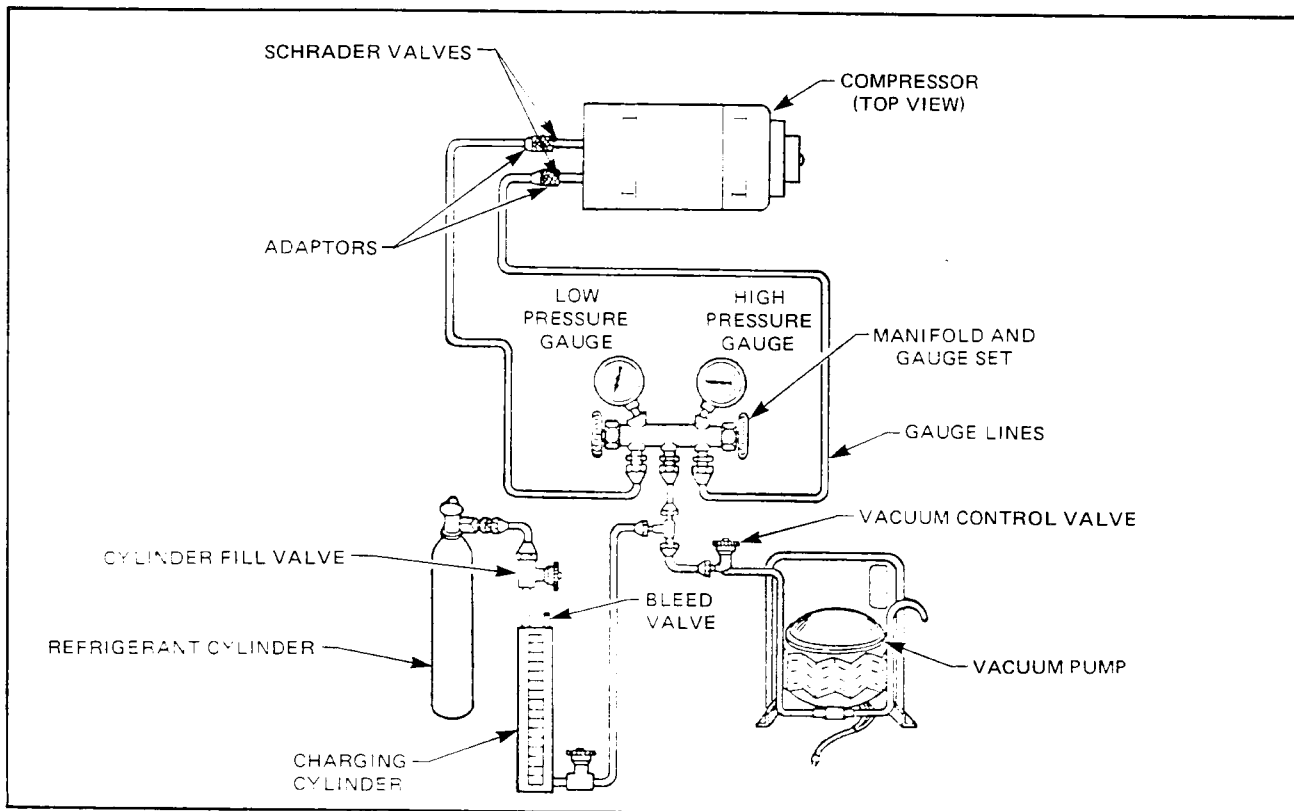

Figure 2B-11

Charging System

The charging process includes the following steps:-

- Filling charging cylinder
- Evacuation and leak test
- Purging (if necessary for repairs)
- Final charging
- Functional Test

Evacuation and Leak Test

1. Open vacuum control valve and gauge set low pressure valve, turn pump on. After several minutes, the low pressure gauge reading should decrease to 98 to 102 kPa vacuum.

NOTE: This specification should be reduced 3.5 kPa for every 300 metres above sea level. Allow pump to operate for 15 minutes after this gauge reading is recorded, close vacuum control valve and turn off pump if system holds vacuum for 5 minutes, commence charging system.

2. If system does not hold vacuum for at least 5 minutes, open refrigerant valve and allow approx 450 grams of refrigerant to enter system. Close refrigerant valve and locate source of leak using a leak detector, and repair leak.

NOTE: Various types and makes of leak detectors are currently in use. Whichever leak detector is used, it is important to follow the manufacturers instructions in regard to adjustment and setting the instrument prior to conducting the test. Inspect for leaks by slowly moving the probe of the detector around all hose connections and points of possible leakage. Refrigerant R12 is heavier than air and will be more apparent at the bottom of a fitting.

3. Close high and low pressure valves at gauge set, purge system as described below.
4. Repeat steps 1 and 2 until system will hold vacuum for at least 5 minutes.

Purging (If Necessary)

Disconnect vacuum line at charging station vacuum pump and lay end of line on a clean rag on the floor. Crack open high and low pressure control valves and allow refrigerant to purge from system. Refrigerant is completely purged when hissing ceases.

NOTE:

- a. Do not open valves too much or compressor oil may be discharged with the refrigerant. Oil loss can be easily detected on rag at discharge line.
- b. Refrigerant must not be purged through vacuum pump as this will aerate oil in pump thus reducing sealing efficiency.
- c. Reconnect vacuum line and close high and low pressure control valves on manifold and gauge set.
- d. Repeat evacuation and leak test.

Charging System

DO NOT START ENGINE

1. Partially charge system with 170 grams (6 ozs) of refrigerant R12 by slowly opening the high pressure valve at the gauge set; gauges should register a pressure, if not, check system for blockage.
2. Close high pressure valve, and **rotate compressor at least 12 turns by hand** to ensure that no liquid

refrigerant is trapped in the suction side of the compressor and that the internal components are coated with lubricant.

NOTE: Failure to comply with this procedure may result in permanent damage to the compressor.

3. Open high pressure side refrigerant valve and allow full charge to enter system - 1050 g. Do not exceed this amount.
4. If the charge will not transfer completely from the station to the system, close the high pressure valve at the gauge set, set the air conditioning controls for cooling, check that the engine compartment is clear of obstructions, start the engine and run at idle speed. Compressor operation will decrease the low side pressure in the system. When low side pressure falls below 275 kPa, crack open low side valve to draw in the remaining refrigerant charge. At no time should the rate of refrigerant drawn in be such that hydraulic noises are created in the compressor by the pumping of liquid. Adjust low side valve opening to achieve this.
5. Remove gauge lines from system and replace protective cap over low pressure schrader valve fitting, then tighten cap securely, fit cutout switch to high pressure schrader valve and tighten securely and leak check.
6. Disconnect main wiring harness from compressor and reconnect cut-out switch leads to main wiring harness and compressor.

WARNING: NEVER RUN COMPRESSOR WITHOUT REFRIGERANT IN THE SYSTEM, AS COMPRESSOR LUBRICATION RELIES ON REFRIGERANT FLOW.

7. Perform functional test.

Functional Testing of System

The functional testing is a quick measurement of the air conditioner system performance. The air outlet vent temperatures and the compressor head and inlet pressures are compared with specified tolerances at the prevailing ambient temperature.

To perform the functional test proceed as follows:-

This test must be performed with the vehicle in the shade i.e. no sun load.

1. Remove the protective caps and cut out switch from the schrader valves on the compressor discharge and inlet fittings. Connect compressor lead to main wiring harness.
2. Connect the manifold and gauge set, charging lines and adaptors to the air conditioning system as shown in Fig. 2B-11.
3. Close all doors, windows and the engine hood.
4. Set the temperature control lever to the cold position, blower fan to high and mode switch to A/C 'MAX' position.
5. Place and operate a high volume industrial type fan in front of the radiator grille to ensure adequate cooling of radiator and condenser.
6. Measure ambient temperature of this fan.
7. Open all air conditioning face level outlet vents.
8. Start engine and run at 2000 rpm with transmission in neutral.
9. Measure the temperature at the centre outlet after running engine for 5 minutes.
10. Compare actual pressures and temperatures with those on functional test table.

2B-14 AIR CONDITIONING

FUNCTIONAL TEST TABLE

Ambient Air Temp. °C Aux. Fan Air Blast	Av. Comp. Head Pressure kPa	Av. Comp. Inlet Pressure kPa	Centre Outlet Air Temp. °C
20	1000 - 1200	55 - 100	4 - 7
25	1100 - 1350	100 - 135	6 - 9
30	1300 - 1450	100 - 135	8 - 11
35	1400 - 1700	100 - 140	10 - 13
40	1700 - 2100	140 - 180	13 - 16.5

If operating pressures and temperatures are within the specifications listed in this functional test table, the refrigerant section of the air conditioning system is functioning correctly.

3.4 COMPRESSOR INSPECTION PROCEDURES

LEAK TEST

Seeping oil does not necessarily indicate leaking refrigerant. Look for the following problems:

- Shaft seal area seeping oil. Feel under seal area between clutch and compressor.
- Dislocation of front boss 'O' ring (protruding section).
- Oil around service port. fittings.
- Oil around filler hole. 'O' ring, stripped threads.
- Oil around crack in compressor housing.

IMPORTANT: Always clean away all oil, grease, etc., and blow away residual refrigerant before starting detection procedures. Refer to System or Supplier Manuals for the proper techniques to be used for Halide or 'Electronic' Leak Detectors.

Halide Flame Detectors - Any portion of the compressor, including the seals, which shows a leak indication on the flame will require leak repair.

'Electronic' - Shop Type Detectors* - In the seal area, set the instrument 1/4 to 1/3 range above maximum sensitivity. All other portions of the compressor - set the detector at maximum sensitivity. (*Detectors with a minimum leak rate of 14-28 cc per year).

'Soap Bubble' - Any bubbles on any portion of the compressor indicate a leak requiring repair.

COMPRESSOR SMOOTHNESS TEST

(Compressor installed)

1. Disconnect refrigerant hoses, discharging system.
2. Disengage clutch.
3. Rotate armature plate by hand.
4. While rotating, if severe rough spots or 'catches' are felt, repair or replace the compressor.

CLUTCH TEST

1. If field coil lead is broken, repair lead or replace field coil.

2. Check current draw and voltage. The amperage range requirement is 3.0 to 3.5 at 12 volts. Note the following symptoms and remedies.

- A very high amperage reading - A short within the field coil.
- No amperage reading - An open circuit in the winding.
- An intermittent or poor system ground results in lower voltage at the clutch. Check for tight fit of coil retaining circlip. Check to determine proper system ground.
- Replace field coil if open or short circuit is found.

3. Air Gap - An incorrect air gap could cause erratic engagement or disengagement and/or clutch rattle. Check the air gap with a feeler gauge 0.35 - 0.65 mm. Adjust as outlined later in this Section.
4. Suspected Bearing Noise - Carry out the following:
Remove belt. Disengage clutch.
Rotate rotor pulley by hand.
Listen for bearing noise. Feel for hard spots. If excessive, repair or replace compressor.

NOISE

Check for:

1. Loose belt, torque to 43 kg (used), 64 kg (new) plus or minus 2.25 kg.
2. Broken bracket and/or compressor body mounting - replace broken component.
3. Missing, broken or loose bolts at compressor and engine fixing points.
4. Torque bolts to specifications.
5. Loose or wobbling engine crankshaft pulley.
6. Alternator bearing.
7. Air pump (where fitted).
8. Water pump bearing.
9. Engine valves.
10. Timing gears.
11. Loose engine mounting bolts.
12. Low refrigerant charge can be determined by persistent foaming in the receiver dehydrator sight glass and low suction pressure together with low head pressure.
13. Oil Level - Insufficient oil can cause unusual noise.

Remove

1. Discharge system as previously outlined in 'Refrigerant System Processing.'
2. Remove hoses from compressor and tape or plug all connections to prevent absorption of moisture from the atmosphere into the system.
3. Slacken off idler pulley clamping nut and/or bolt then disconnect the drive belt.

NOTE: On 6 cylinder engines, it will be necessary to release the tension from the compressor drive belt adjusting bolt, illustrated in Fig. 2B-9.

4. Disconnect electrical connector then remove the attaching bolts and compressor from the mounting bracket.
5. If the original or a new compressor is being reinstalled, or replaced, refer to 'Add Oil During Component Replacement' 2.3 in this Section.

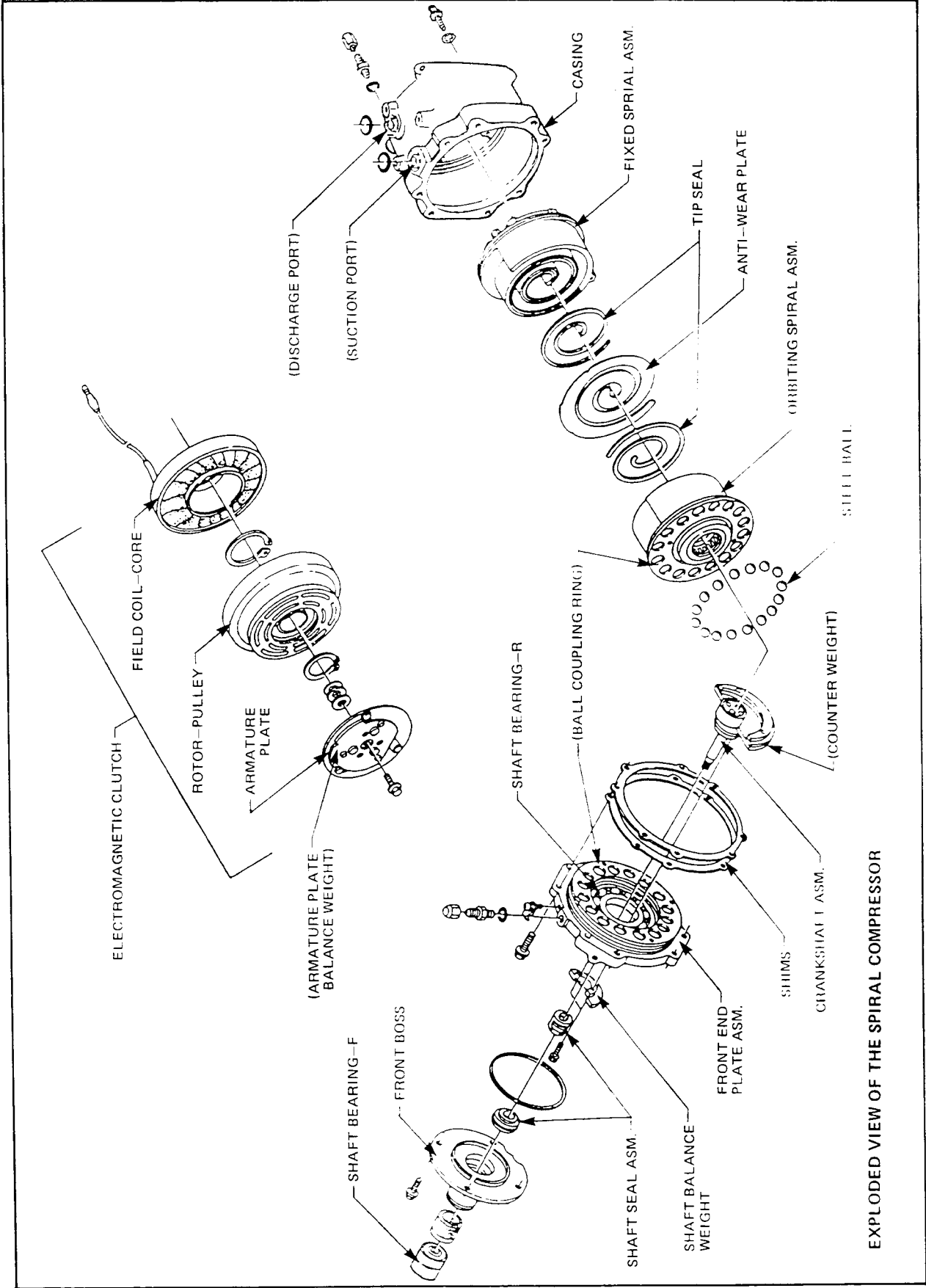

Figure 2B-12

2B-16 AIR CONDITIONING

Reinstall

Reverse to removal procedures noting the following:

1. Torque mounting bolts as shown in Figs. 2B-9 or 2B-10.
2. Leave protective plugs or caps until just before connecting tubes or hoses to prevent absorption of moisture from the atmosphere into the system.
3. Install new 'O' ring seals after lubricating them with refrigerant oil, then torque hose connections as shown in Figs. 2B-5, 2B-6 or 2B-7.
4. Adjust the drive belt as outlined under 'Compressor Drive Belt Tension Adjustment' to 43 kg (used) or 64 kg (new) plus or minus 2.25 kg.
5. Charge the system as outlined under 'Refrigerant System Processing.' Parts illustrated in Fig. 2B-12 which are serviced for the TR70 Spiral compressor include:

1. Armature Plate
2. Armature Plate Balance Weight
3. Rotor Pulley
4. Field Coil Core
5. Shaft Bearing - Front
6. Front Boss
7. Shaft Seal Assembly

Disassembly

CAUTION: Tool No. 41267, seal seat remover and installer must be used to ensure that no contamination i.e. dirt, human perspiration, etc., is allowed onto the seal area. With a new seal, it is imperative that it be unpacked carefully and fitted onto Tool 41267 for installation onto the compressor shaft.

1. Mount holding fixture AU258 into a vice, then using the pins supplied with the fixture, secure the compressor assembly mounting holes onto the holding fixture bosses as illustrated in Fig. 2B-13.

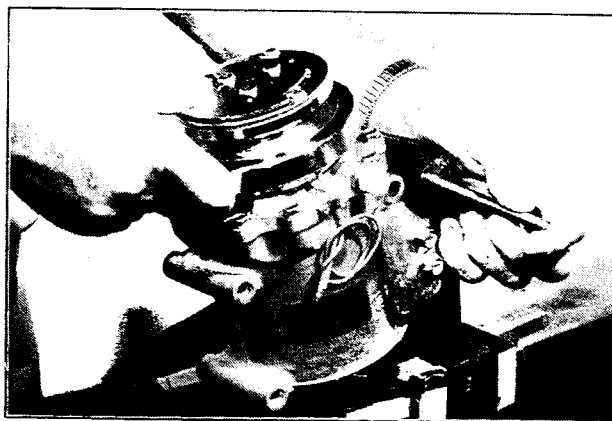

Figure 2B-13

2. Insert pins of turning stop tool AU259 into holes of armature, then using an 8 mm socket with ratchet handle attached, remove armature anchor bolt as illustrated in Fig. 2B-14, then remove armature.

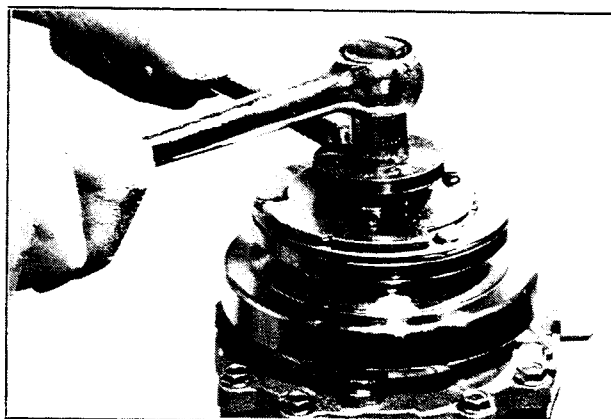

Figure 2B-14

3. Remove shim(s) from top of compressor shaft then using wing circlip pliers J6083, remove the circlip securing the clutch rotor to the clutch core as illustrated in Fig. 2B-15, then lift the clutch rotor assembly off the compressor shaft.

NOTE: If difficulty is experienced in removing the clutch bearing, locate the ends of two bladed screwdrivers into grooves inside of clutch rotor, then using a lever action, lever clutch rotor up and off the compressor shaft.

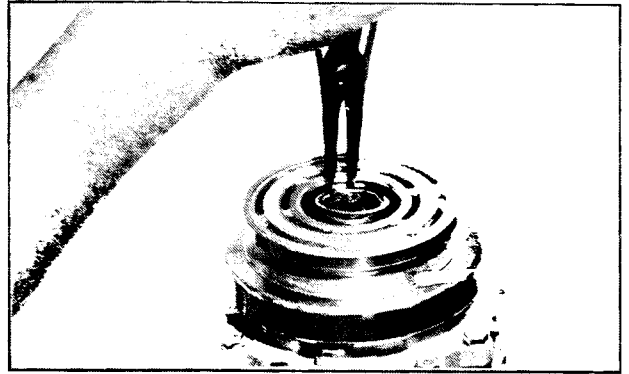

Figure 2B-15

4. Loosen the clutch lead wire clamp releasing the lead, then using wing circlip pliers J6083, remove the circlip securing the clutch core assembly in the stepped section of the front nose as illustrated in Fig. 2B-16, then remove the clutch core assembly off the compressor shaft.

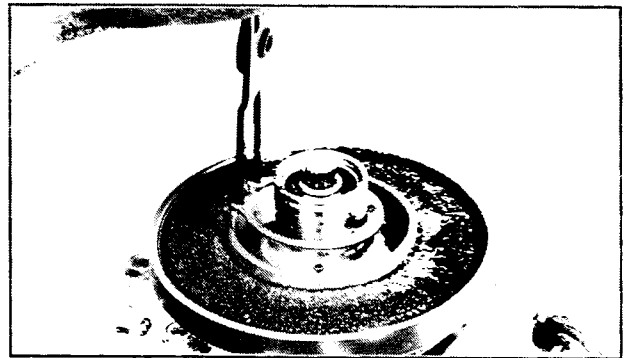

Figure 2B-16

5. Using a 10 mm socket with a ratchet handle attached, remove the four bolts securing the front nose to the front end plate as illustrated in Fig. 2B-17. Lift the front nose off the compressor shaft as illustrated in Fig. 2B-18, then remove the square sectioned 'O' ring from the end plate.

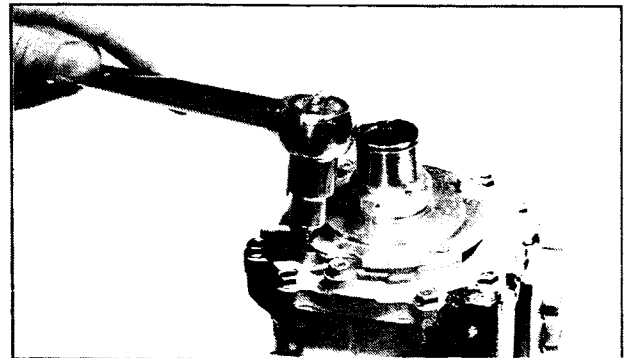

Figure 2B-17

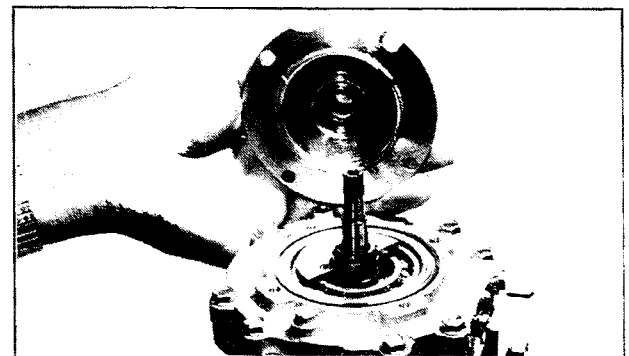

Figure 2B-18

2B-18 AIR CONDITIONING

6. Install the 'O' ring protecting tool AU261 over the end of the compressor shaft then install the seal head removal and installation tool 41267 over the protecting tool and compressor shaft, as illustrated in Fig. 2B-19. Depress then rotate the tool in a clockwise direction to engage cutouts in bottom of head with seal head retainer, then remove the seal head.

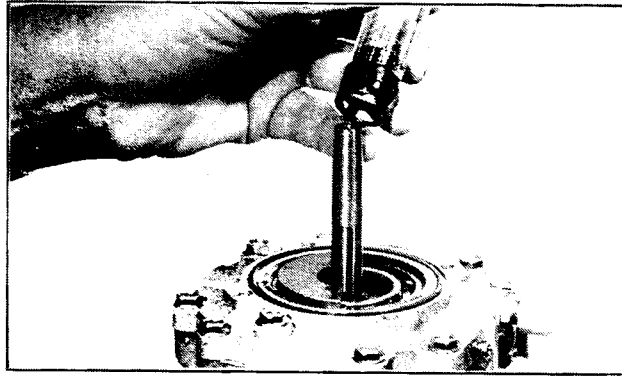

Figure 2B-19

7. Depress arms of the seal seat removal and installation tool AU260 and install the tool into the inside of the seal seat as illustrated in Fig. 2B-20. Allow the ends of the tool to expand and engage into recesses on the base of the seal seat. Using a pulling action, lift seal seat out of seal head.

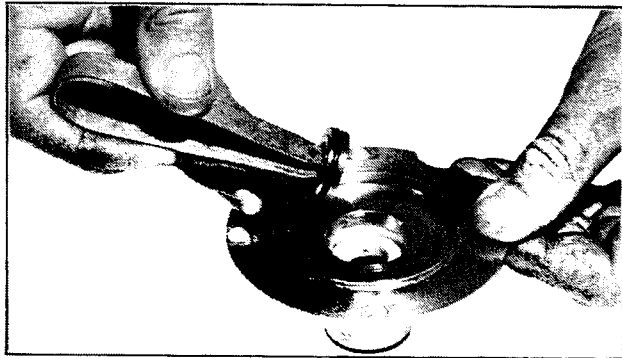

Figure 2B-20

8. Depress arms of the seal seat removal and installation tool AU260 and install the ends of the tool in between the base of the metal cap retainer to which the felt seal is attached and the front nose. Carefully work the ends of the tool around the base of the felt seal retainer, then using a pulling action, lift felt seal assembly out of the front nose as illustrated in Fig. 2B-21.

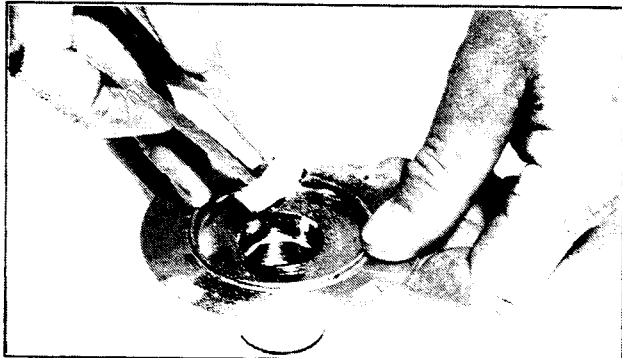

Figure 2B-21

Reassembly

1. Install the felt seal assembly onto the felt seal assembly installing tool AU262, then install the seal assembly firmly into the bore of the front nose, as illustrated in Fig. 2B-22.



Figure 2B-22

2. With the seal seat installed on the end of tool AU260, apply refrigerant oil to the seat 'O' ring, then install the seal seat into the bore of the front nose with the 'O' ring uppermost. Using the felt seal assembly installing tool AU262 located on top of the seal seat, exert sufficient downward pressure to correctly install seal seat.

NOTE: Refer to cautionary paragraph at start of Disassembly procedures.

3. With 'O' ring protecting tool AU261 installed on end of compressor shaft and with seal head installed in end of tool 41267, thoroughly air blow seal head, then apply refrigerant oil to 'O' ring.
4. Install seal head onto compressor shaft illustrated in Fig. 2B-23, then applying downward pressure, rotate tool and head to align flats on the base of the seal head with those on the compressor shaft.
5. Remove 'O' ring protecting tool AU261 from end of compressor shaft then install square sectioned 'O' ring into groove on the end plate.

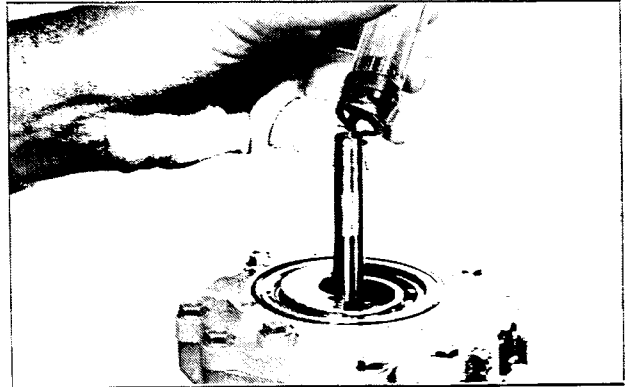

Figure 2B-23

6. Align notched edge of front nose with front plate retaining bolt illustrated in Fig. 2B-24 and install the front nose, ensuring that the square sectioned 'O' ring on the front plate remains in its groove. Apply downward pressure on the front nose to overcome spring tension from the seal head, then install and torque front nose to front end plate attaching bolts in diagonal sequence to $14.71 \pm .98$ Nm.

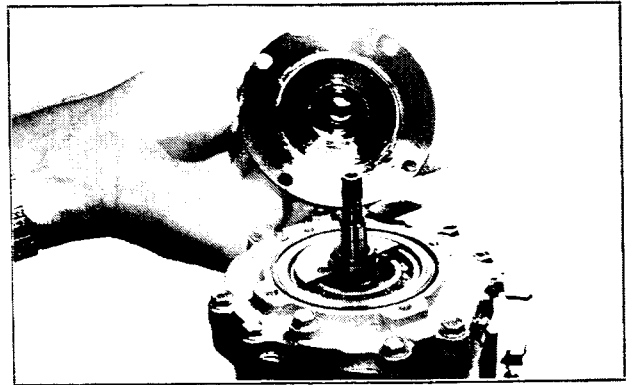

Figure 2B-24

7. Install the clutch core assembly to the front end nose, aligning the locating projection dimple in the base of the clutch circlip core assembly with cut out in end plate. Using wing circlip pliers J6083, install clutch core assembly as illustrated in Fig. 2B-25.

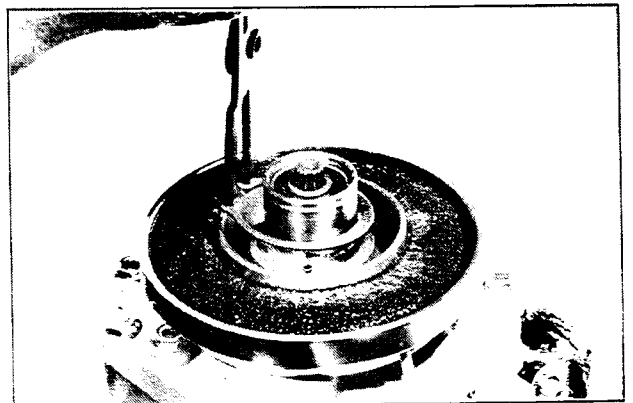

Figure 2B-25

2B-20 AIR CONDITIONING

8. Replace the clutch lead wire and tighten the retaining clamp, then install the clutch rotor, using wing circlip pliers J6083 to secure the rotor to the clutch core as illustrated in Fig. 2B-26.
9. Install the shim(s) to the end of the compressor shaft.

NOTE: These shims adjust the air gap (refer air gap adjustment in subsequent service operations).

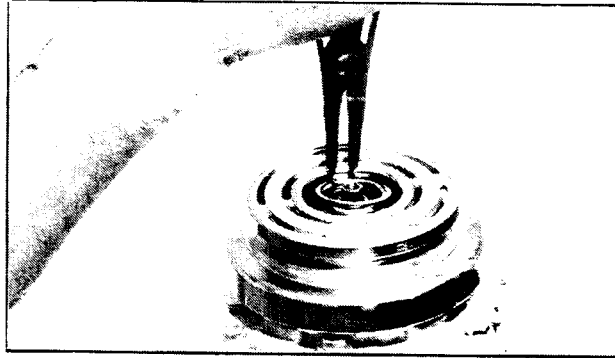

Figure 2B-26

10. Install the clutch armature, aligning flat on end of compressor shaft with corresponding flat on armature. Using turning stop tool AU259 and an 8 mm socket with ratchet handle attached, install and torque armature anchor bolt to $9.81 \pm .98$ Nm, as illustrated in Fig. 2B-27.

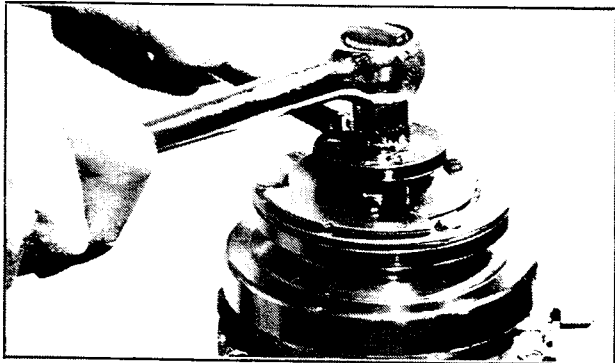

Figure 2B-27

AIR GAP ADJUSTMENT

Measure air gap between clutch armature and clutch rotor assemblies, using feeler gauges as illustrated in Fig. 2B-28.

Recommended air gap is 0.35 - 0.65 mm. If adjustment of the air gap is indicated, remove anchor bolt and armature clutch assembly (refer preceding instructions) then adjust shim thickness to achieve the recommended air gap.

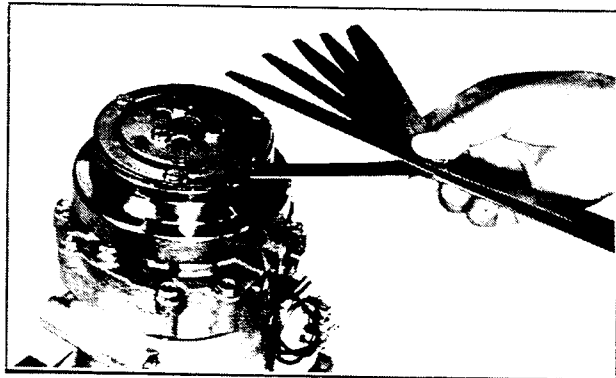

Figure 2B-28

3.5 EVAPORATOR ASSEMBLY

REMOVE

1. Disconnect the battery earth cable.
2. Evacuate the system (refer 'Refrigerant System Processing' in this Section).
3. Disconnect the inlet and outlet refrigerant pipe connections illustrated in View 'A', Fig. 2B-33, from the evaporator core.
4. Remove transmission console (refer 2.2 or 2.3 in the Body Section of this Supplement).
5. Remove heater case to panel cover assembly, lower instrument panel extension, touch switch control panel and centre nozzle and instrument location frame illustrated in Fig. 2B-29.

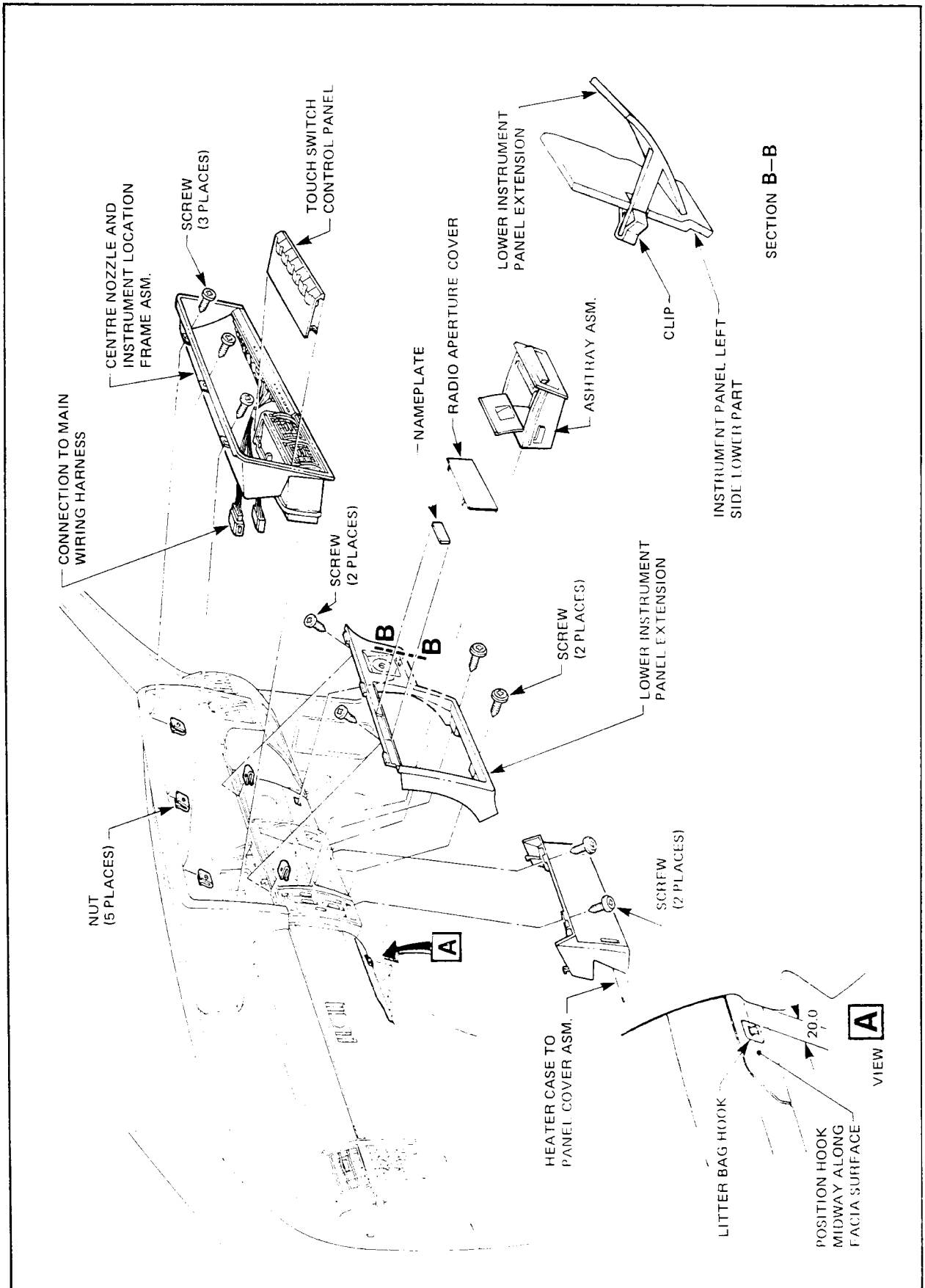

Figure 2B-29

2B-22 AIR CONDITIONING

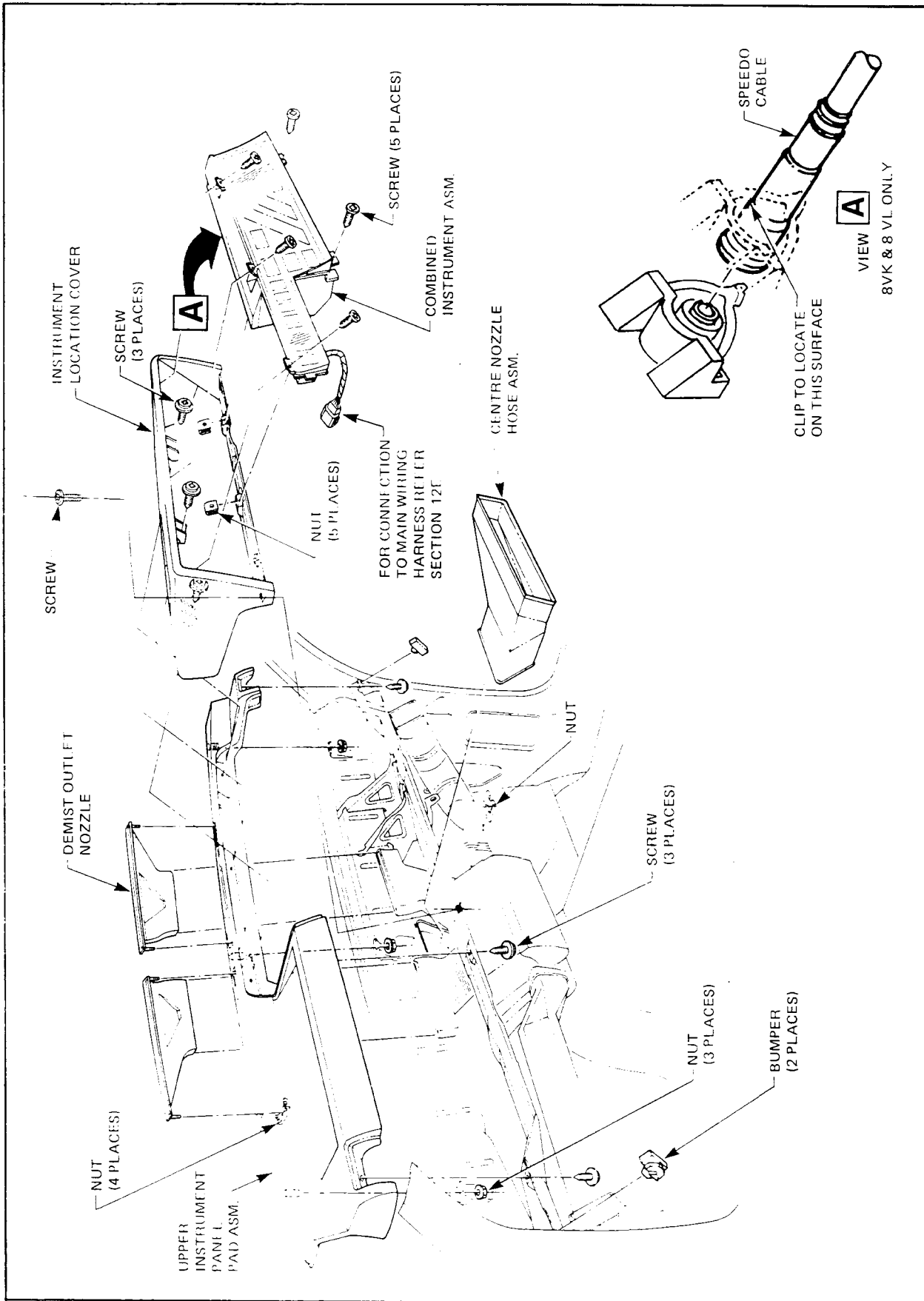

Figure 2B-30

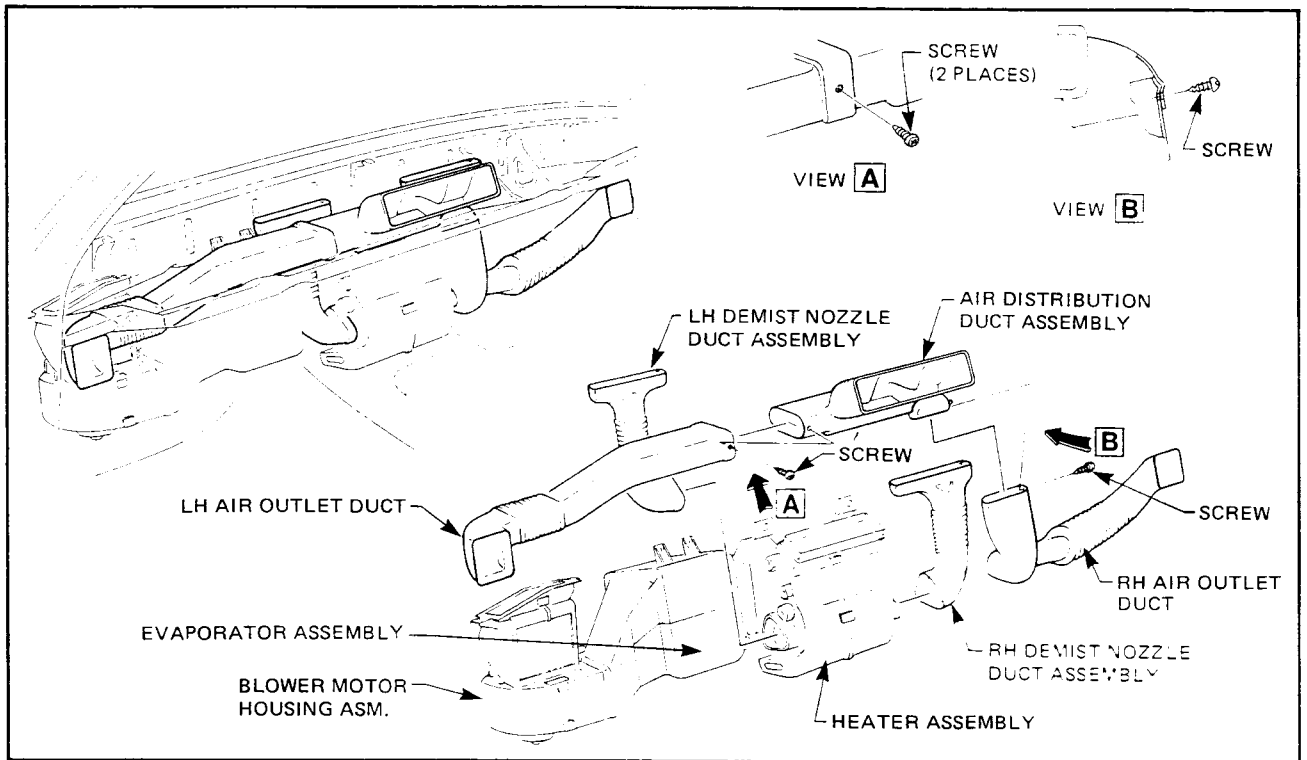

Figure 2B-31

6. Remove combined instrument assembly illustrated in Fig. 2B-30.
7. Disconnect temperature cable at heater assembly and partially remove vent/heat control assembly - Do not disconnect vacuum hoses or electrical connector.
8. Remove screws securing left hand and centre of instrument location cover to instrument panel pad and frame illustrated in Fig. 2B-30.
9. Remove centre nozzle hose assembly and screws securing right and left hand air ducting to centre air duct illustrated in Figs. 2B-30 and 2B-31.
10. Remove instrument panel compartment and rear compartment release button.
11. Remove left hand upper air outlet assembly and screw securing left hand of instrument panel pad to frame illustrated in Figs. 2B-30 and 2B-32.
12. Firmly support left hand instrument panel lower and remove all of the screws securing this panel to the instrument panel frame illustrated in Fig. 2B-32.
13. Remove left hand air outlet duct illustrated in Fig. 2B-31, from under left hand side of instrument panel, taking care not to place undue pressure on left hand instrument panel lower.
14. From under the instrument panel, disconnect the drain tube illustrated in View 'A' Fig. 2B-33 from the base of the evaporator assembly.
15. Position a wooden wedge between the left hand side of the instrument panel pad and the instrument panel frame to gain access to the two bolts illustrated in Fig. 2B-33, which secure the top of the evaporator assembly to the instrument panel frame, then using a socket extension and a ratchet handle, remove the bolts securing the evaporator assembly to the instrument panel frame.

2B-24 AIR CONDITIONING

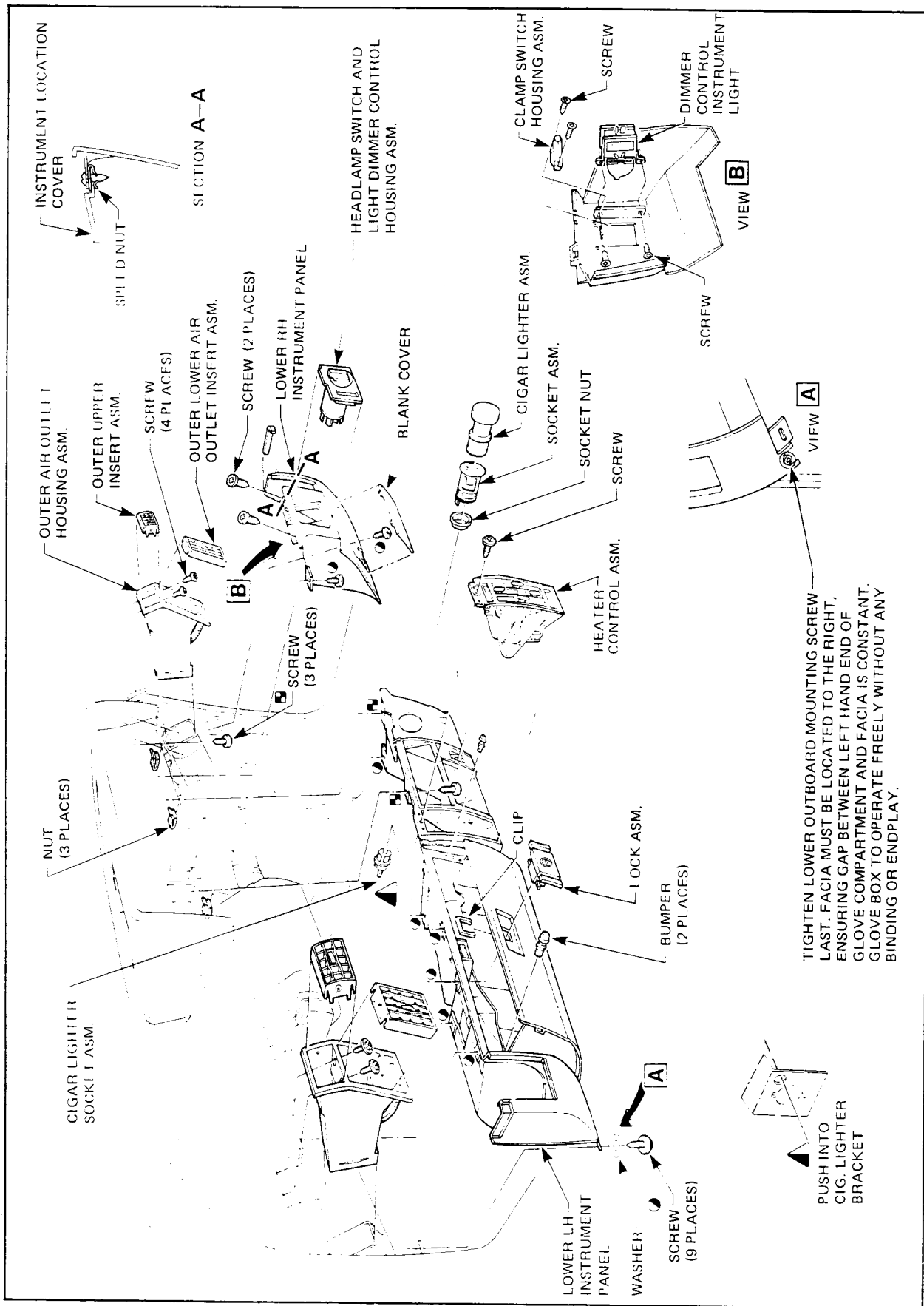

Figure 2B-32

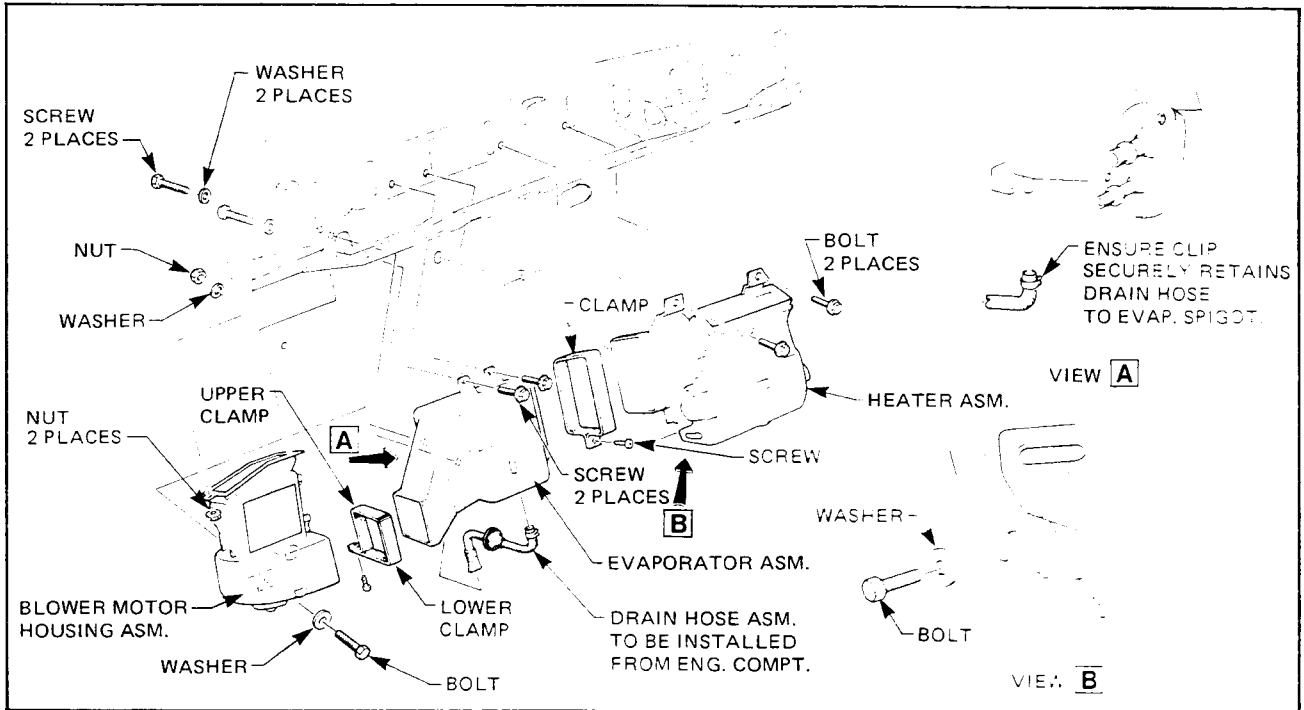

Figure 2B-33

16. From inside the engine compartment, remove the two bolts illustrated in Fig. 2B-33, securing the front of the evaporator assembly to the lower dash panel.

CAUTION: Cap or plug evaporator core pipes and refrigerant tube connections as soon as connections are broken to prevent absorption of moisture from the atmosphere into the system.

17. Remove the clamps illustrated in Fig. 2B-33, which retain and seal the ends of the evaporator housing to the heater and blower motor housing assembly, disconnect the electrical connectors and vacuum hoses, then carefully remove the evaporator ass

REINSTALL

Reverse removal operations noting the following:

1. If the original or a new evaporator is to be installed, refer to 'Adding Oil During Component Replacement' in this Section.
2. Leave protective plugs or caps until just before connecting tubes or hoses to prevent absorption of moisture from the atmosphere into the system.
3. Install new 'O' ring seals, lubricating them with refrigerant oil then torque A/C hose connections as illustrated in Figs. 2B-5, 2B-6 and 2B-7.
4. Charge the system as outlined under 'Refrigerant System Processing' in this Section.
5. Check out the electrics and air ducts disturbed during the removal and installation operations.

2B-26 AIR CONDITIONING

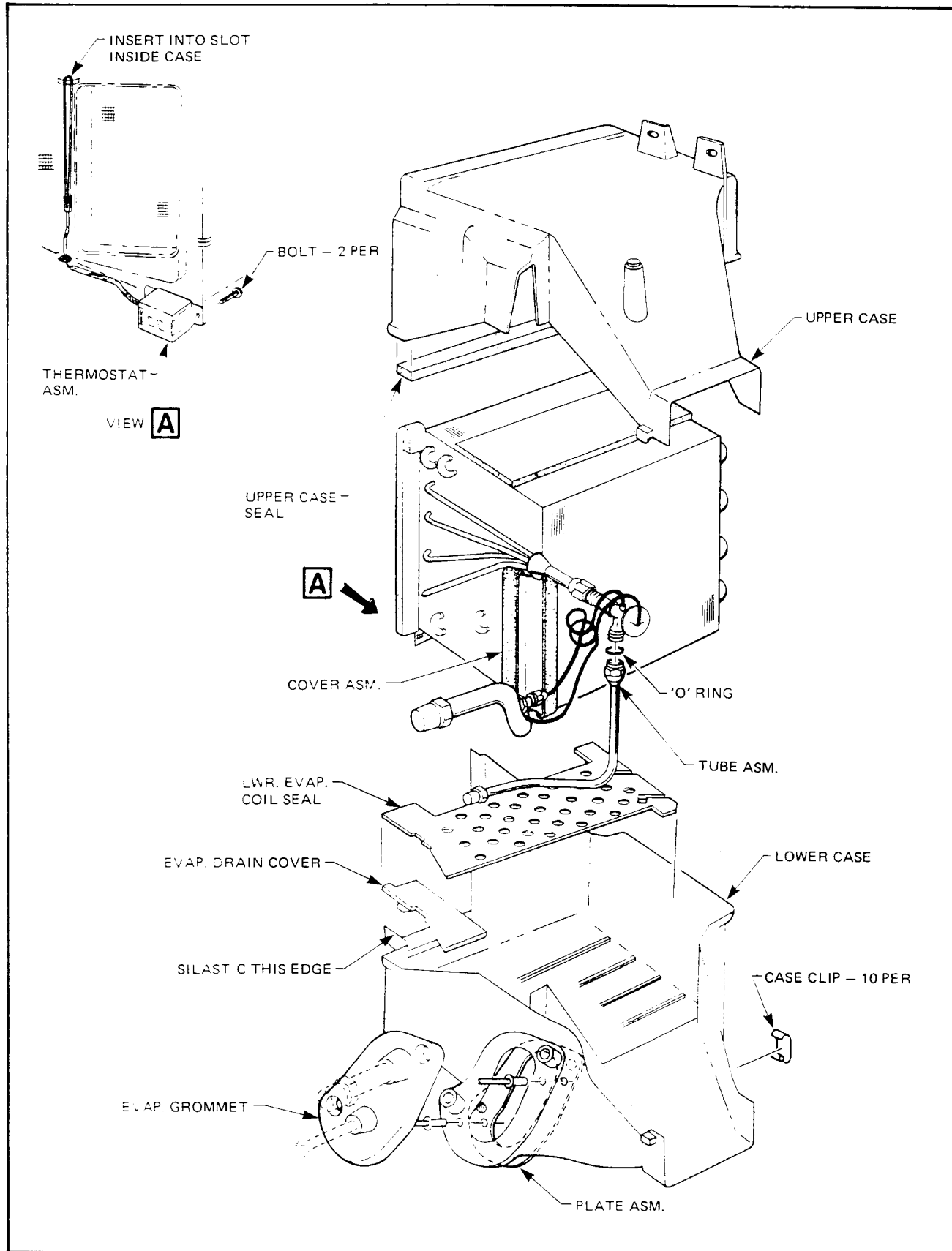

Figure 2B-34

3.6 EVAPORATOR CORE AND PIPE ASSEMBLY

REMOVE

1. Remove evaporator assembly as described in the preceding procedures.
2. Remove the spring clips illustrated in Fig. 2B-34 which secure the upper and lower sections of the evaporator case together.
3. Remove the heavy mastic insulation material adjacent to the expansion valve and inlet and outlet pipes.
4. Whilst removing the upper section of the evaporator case, carefully ease the TXV sensor tube illustrated in View 'A' Fig. 2B-34, from the slot in the inside case.
5. Remove the rubber sealing gasket and the inlet pipe illustrated in Fig. 2B-34 from the evaporator core and pipe assembly.
6. Carefully withdraw the core from the lower section of the evaporator case taking care not to contact the aluminium mesh water collector screen attached to the rear section of the pipe and core assembly by hand.

NOTE: During manufacture, this water collector is chemically treated to create a slippery surface to accelerate moisture movement. Acid deposits which can result from touching this surface by hand can neutralize this chemically treated surface.

REINSTALL

When installing the new assembly note the following:

1. Drain as much of the original refrigerant oil as possible from the original evaporator core, then add the same amount of new refrigerant oil, either to the original or new evaporator core.
If the evaporator assembly contains more than 25 cc of refrigerant oil, assume system contains excess oil and flush system, then add 150 cc of new refrigerant oil to compressor.
2. Leave protective plugs or caps until just before connecting tubes or hoses to prevent absorption of moisture from the atmosphere into the system.
3. Use new 'O' ring seals coated with clean refrigerant oil when making inlet and outlet tube connections.
4. Leave final tightening of the tube connections until the evaporator is securely installed.
5. Evacuate, leak test, charge and performance test the system.

NOTE: Removal and reinstallation of the thermostatic expansion valve and the thermostat and switch assembly necessitate removal of the evaporator assembly.

3.7 CONDENSOR AND AUXILIARY FAN ASSEMBLY

REMOVE

1. Disconnect battery earth cable.
2. Evacuate the system (refer 'Refrigerant System Processing' in this Section).
3. Remove the radiator grille, illustrated in Fig. 2B-35.
4. Disconnect the electrical connectors, then remove the auxiliary fan blade from the fan motor assembly

attached to condenser assembly, illustrated in Fig. 2B-36.

5. Remove the screws illustrated in Fig. 2B-36 securing the right hand bracket to the condenser and the radiator side support panel.
6. Disconnect the inlet and outlet refrigerant pipe connectors located on the right hand side of the condenser assembly.

CAUTION: Cap or plug disconnected connectors on pipes and on condenser immediately to prevent moisture being absorbed from the atmosphere into the system.

7. Disconnect the horn bracket lead, then remove the horn and bracket assembly from the left hand radiator side support panel.
8. From under the front lower valance panel, remove the two screws illustrated in Fig. 2B-36, securing the right and left hand brackets attached to the base of the condenser assembly.
9. Remove the screw illustrated in Fig. 2B-36 securing the left hand upper support bracket to the radiator side support panel, then remove the condenser and auxiliary fan motor assembly.

REINSTALL

Reverse removal procedures. When installing the new assembly, note the following:

1. Drain as much of the original oil as possible from the original condenser, then add the same amount of new refrigerant oil, either to the original or new condenser.
If the condenser contains more than 25 cc of refrigerant oil, assume system contains excess oil and flush system. Add 150 cc of new refrigerant oil to the compressor.
2. Leave protective plugs or caps until just before connecting tubes to prevent absorption of moisture from the atmosphere into the system.
3. Use new 'O' ring seals coated with clean refrigerant oil when making inlet and outlet tube connections.
4. Leave final tightening of the tube connections until the condenser is finally installed.
5. Evacuate, leak test, charge and performance test the system.

3.8 AUXILIARY FAN

REMOVE

1. Disconnect the battery earth cable and the auxiliary fan electrical connector located on the left hand side of the condenser assembly.
2. Remove the connector body from the end of the auxiliary fan lead, then attach a length of string to the end of the lead.
3. Remove the radiator grille illustrated in Fig. 2B-35.
4. Remove the nuts securing the auxiliary fan to the condenser, then remove the fan and lead assembly, leaving enough of the string previously attached to the fan lead adjacent to the top of the radiator to facilitate subsequent installation of the fan lead.

REINSTALL

Reverse removal procedures.

2B-28 AIR CONDITIONING

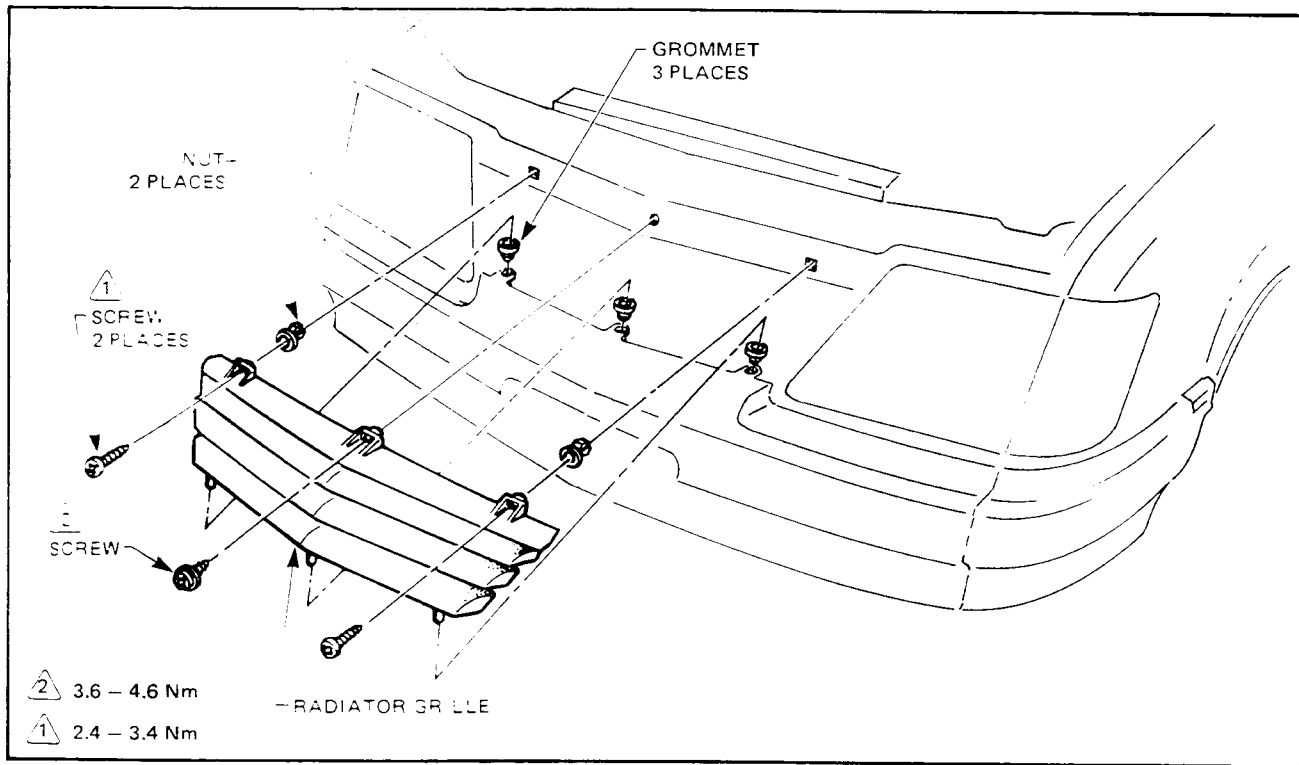

Figure 2B-35

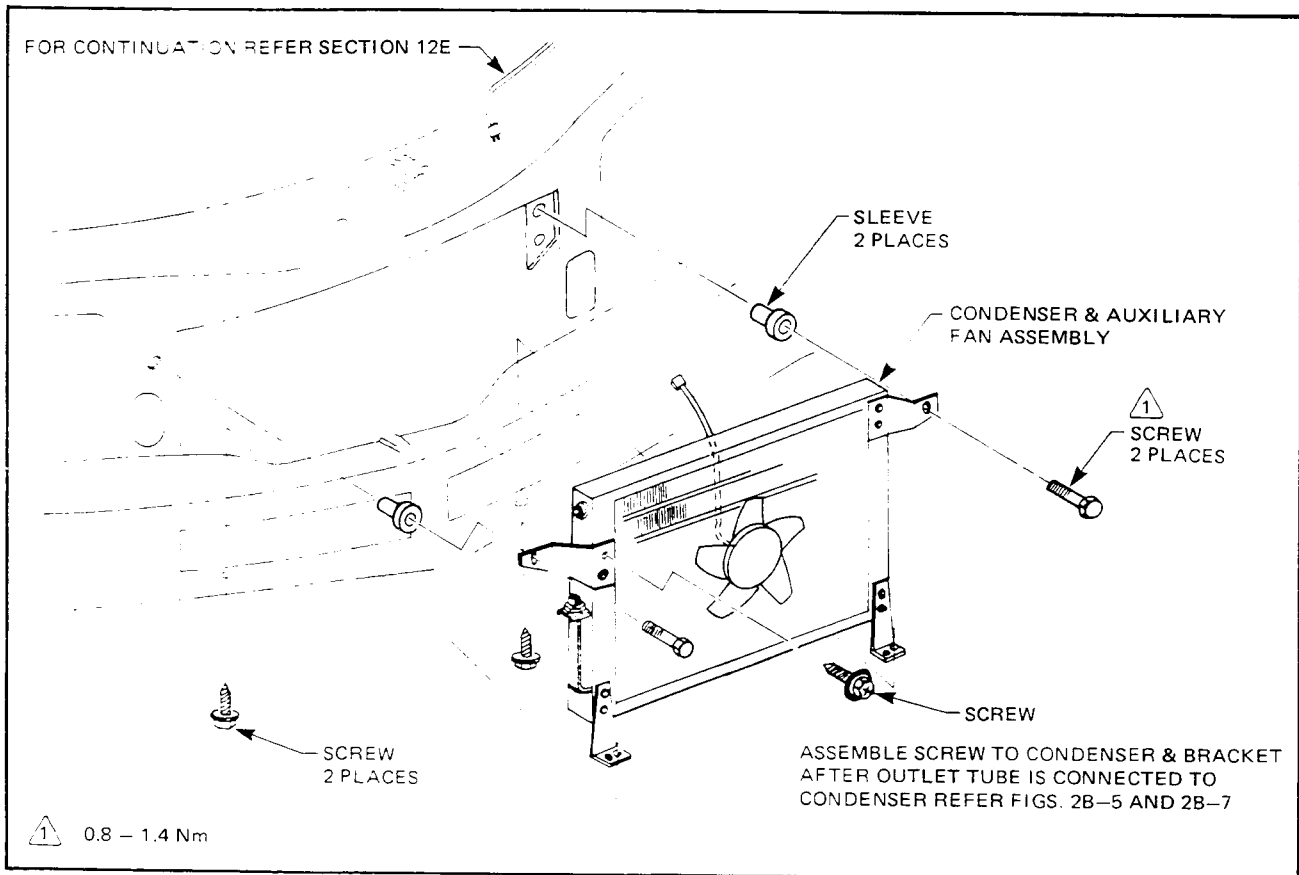

Figure 2B-36

3.9 RECEIVER DEHYDRATOR

REMOVE

1. Evacuate the system (refer 'Refrigerant System Processing' in this Section).
2. Disconnect the inlet and outlet refrigerant pipes from the inlet and outlet sides of the receiver dehydrator illustrated in Fig. 2B-37.

CAUTION: Cap or plug disconnected connectors on pipes and on receiver dehydrator immediately to prevent absorption of moisture from the atmosphere into the system.

3. Loosen the screw clamp illustrated in View 'A', Fig. 2B-37, then slide the receiver dehydrator out of the clamp.

NOTE: If the receiver dehydrator is left open to the atmosphere for more than 15 minutes, the receiver dehydrator should be replaced.

REINSTALL

Reverse removal procedures.

When installing a new assembly note the following:

1. Drain as much of the original oil as possible from the original receiver dehydrator, then add the same amount of new refrigerant oil, to the original or new receiver dehydrator.

If the receiver dehydrator contains more than 25 cc of refrigerant oil, assume system contains excess oil and flush system. Add 150 cc of new refrigerant oil to compressor.

2. Leave protective plugs or caps until just before connecting tubes to prevent absorption of moisture from the atmosphere into the system.
3. Use new 'O' ring seals coated with clean refrigerant oil when making inlet and outlet tube connections.
4. Leave final tightening of the tube connections until the receiver dehydrator clamp is fully tightened.
5. Evacuate, leak test, charge and performance test the system.

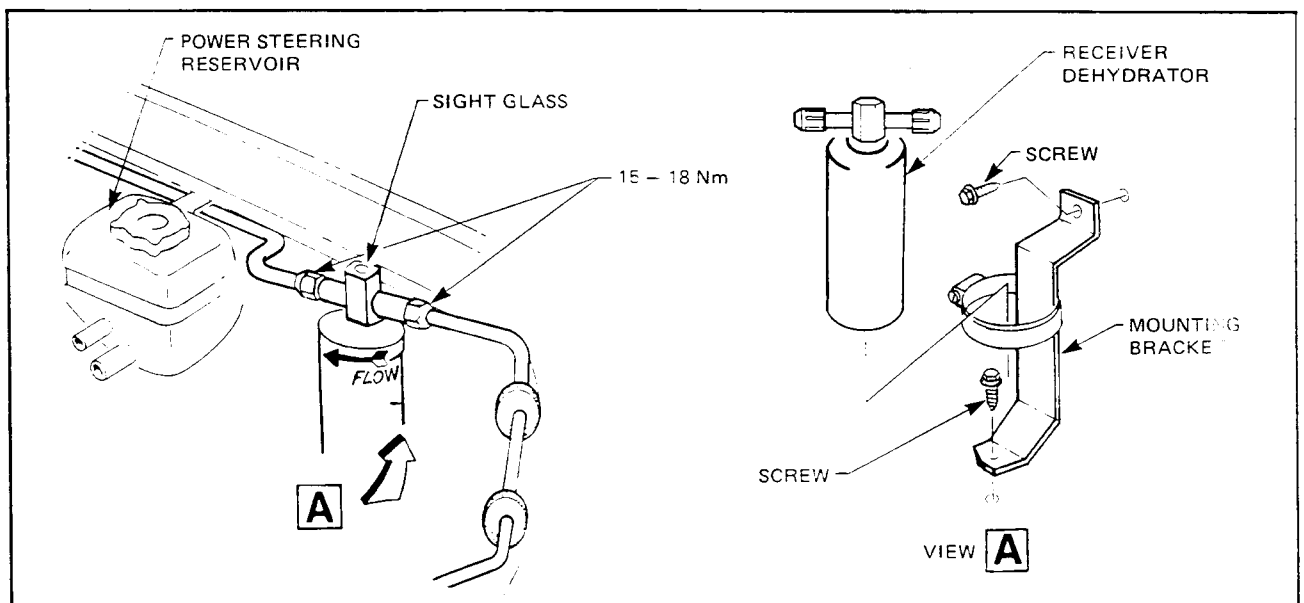
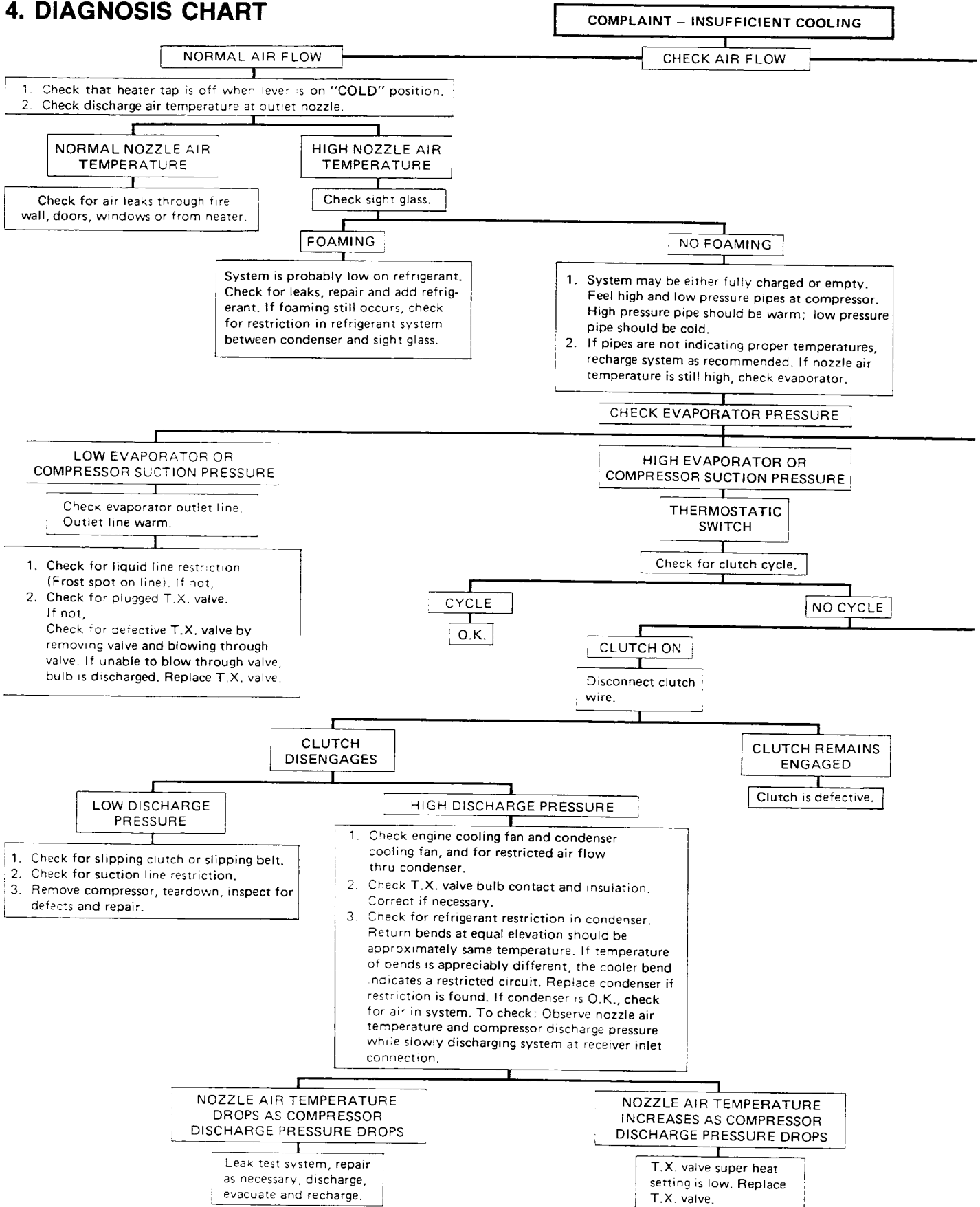
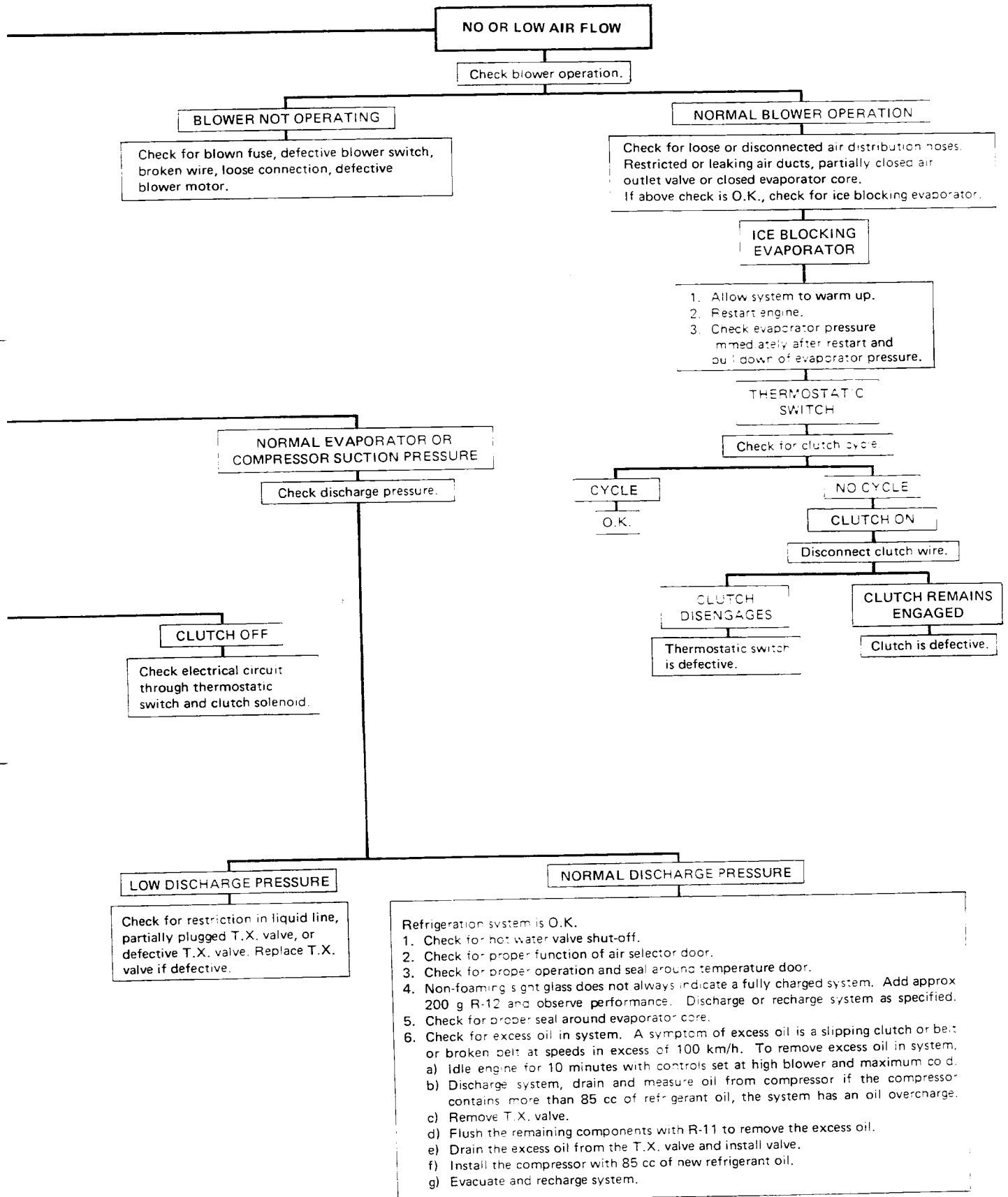

Figure 2B-37

2B-30 AIR CONDITIONING

4. DIAGNOSIS CHART





2B-32 AIR CONDITIONING

5. SPECIAL TOOLS

The Compressor Tools are available either in kit form as Tool No. AU263, or as separate items under their individual Tool number. A Belt Tension Gauge is also available. These Special Tools are available from,

Kent Moore — Australia Pty. Ltd.
Unit 3, 9 Pioneer Avenue,
THORNLEIGH, N.S.W. 2120.

Telephone. (02) 848 9777 Telex. 22355

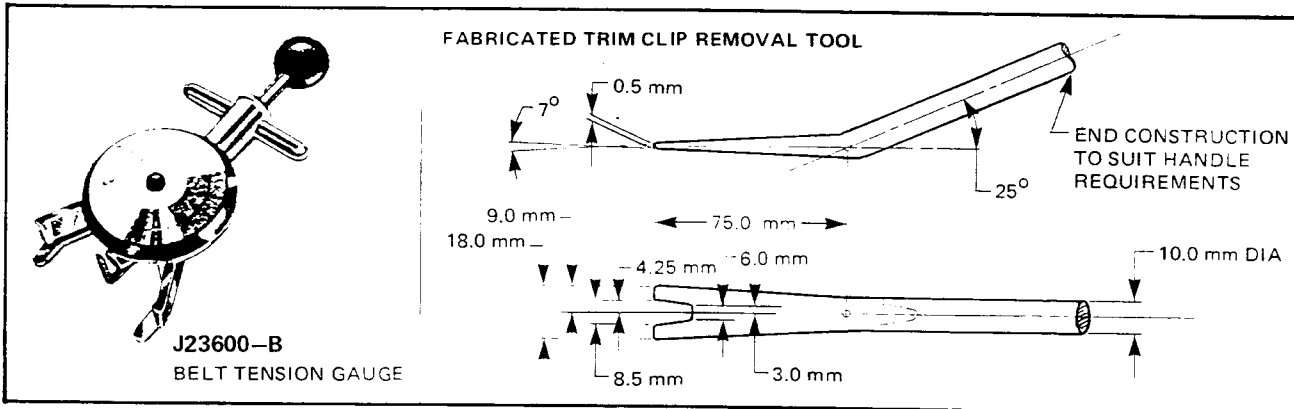

AU263 — SANDEN COMPRESSOR TOOL KIT

COMPRISING THE FOLLOWING TOOLS

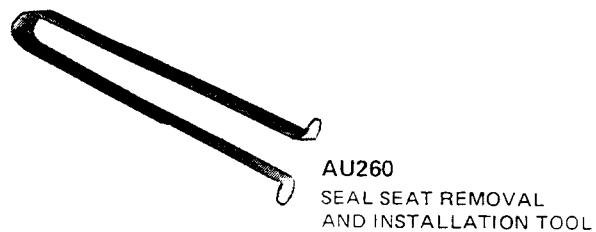
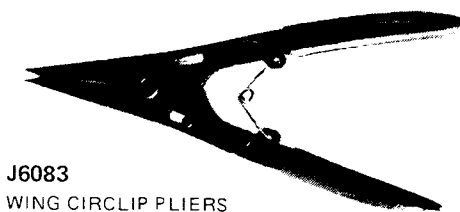
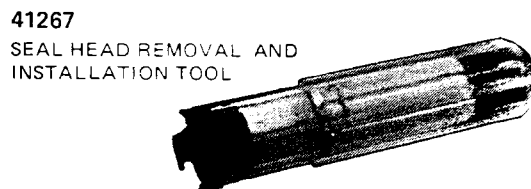
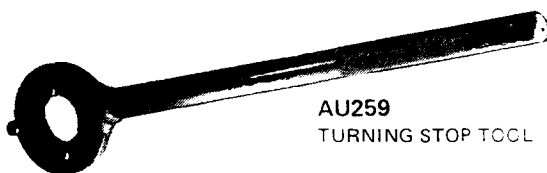
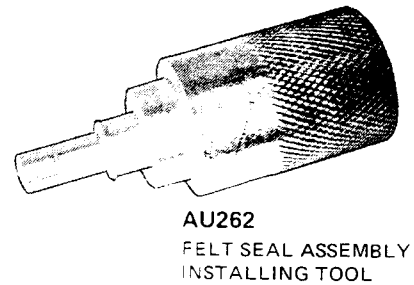
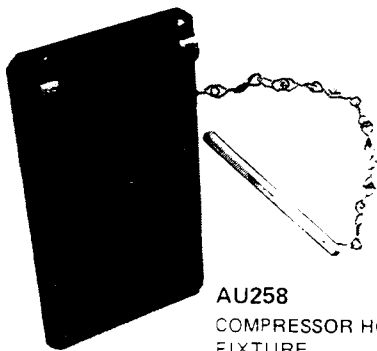

SECTION 3

FRONT SUSPENSION

INDEX

Ref.	Subject	Page	Ref.	Subject	Page
1.	GENERAL DESCRIPTION	3-1	2.	FRONT STRUT USAGE	3-1

1. GENERAL DESCRIPTION

The front suspension on VK Series models remains the same as on VH Series models, with the exception of the front strut shock absorbers. These have been revised to suit the different variation in vehicle load and to maintain satisfactory damping control. VK strut inserts are not

interchangeable with previous Commodore models. Service operations are as described in Section 03 of the VB Commodore Service Manual P/N M38145.

2. FRONT STRUT USAGE

All VK Series models have the front strut assemblies painted black, there is no colour identification as per previous Commodore models.

For non-standard strut identification, refer to the 'Body and Identification Plate'. The plate includes vehicle optional information if it is fitted with XW5 - Outback Pack or FE-2 Sports Suspension Pack, refer Fig. 3-1.

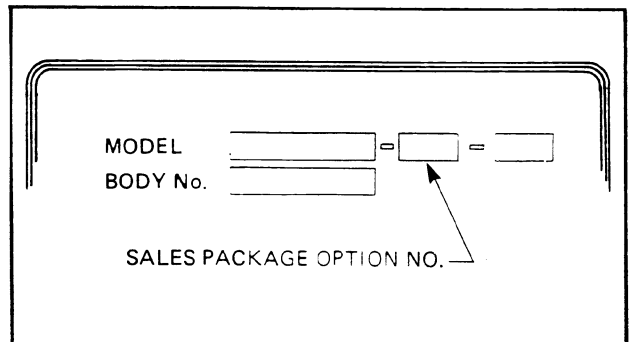

Figure 3-1

SECTION 4A

REAR SUSPENSION

INDEX

Ref.	Subject	Page	Ref.	Subject	Page
1.	GENERAL DESCRIPTION	4A-1	3.	SPECIFICATIONS	4A-2
2.	SERVICE OPERATIONS	4A-1	3.1	REAR SHOCK ABSORBER USAGE	4A-2

1. GENERAL DESCRIPTION

The rear suspension on VK Series models remains the same as on VH Series models, with the exception of the shock absorbers. These have been revised to suit the

different variation in vehicle load over VH Series models. Service operations are as described in Section 04 of the VB Commodore Service Manual.

2. SERVICE OPERATIONS

Service operations are as described in the VB Commodore Service Manual Part Number M38145.

NOTE: Any service operation that requires the removal and reinstallation of the upper control arm to axle attaching bolts, on installation they must be inserted in an inward direction. Refer Fig. 4A-1.

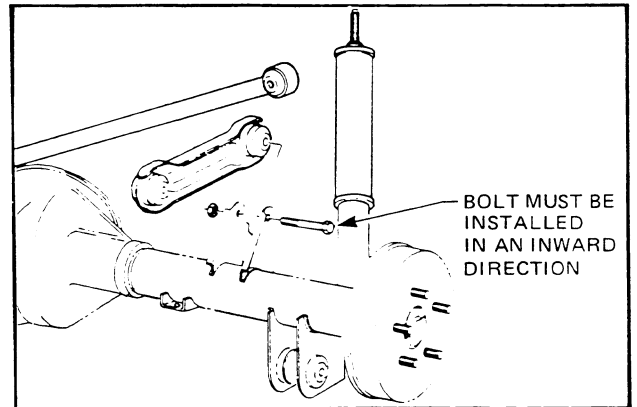

Figure 4A-1

SECTION 4B

REAR AXLE

INDEX

Ref.	Subject	Page	Ref.	Subject	Page
1.	GENERAL DESCRIPTION	4B-1	2.	SERVICE OPERATIONS	4B-1

1. GENERAL DESCRIPTION

There are two different size Salisbury Rear Axle Assemblies used with VK Series models.

- | | |
|---|--|
| <ol style="list-style-type: none"> 1. A Salisbury type axle with 178 mm diameter ring gear is used as standard equipment on all models except those with the 5.0 litre engine. | <ol style="list-style-type: none"> 2. A Salisbury type axle with 190 mm diameter ring gear is used on models with 5.0 litre engine. Limited slip differential is available on all models. |
|---|--|

2. SERVICE OPERATIONS

There have been some revisions to the rear axle assemblies for VK compared with those fitted to VH Series models.

1. The hypoid pinion has been shot peened.
2. The differential pinion shaft has been nickle plated.
3. The hypoid pinion bearing spacer has been surface hardened, by a process of nitro carburizing.

NOTE: Components from previous Holden models must not be substituted for the above components when overhauling the rear axle assemblies on VK Series models.

The remainder of the axle components are identical to those used on previous Holden models.

For servicing and overhaul procedures refer to the VB Commodore Service Manual Part No. M38145.

SECTION 4C

PROPELLER SHAFT & UNIVERSAL JOINTS

INDEX

Ref.	Subject	Page	Ref.	Subject	Page
1.	PROPELLER SHAFT IDENTIFICATION	4C-1	2.	UNIVERSAL JOINTS	4C-1

1. PROPELLER SHAFT IDENTIFICATION

The following chart sets out the propeller shaft usage for VK Series models.

ENGINE	TRANSMISSION	PROPELLER SHAFT	
		PART NO.	COLOUR
3.3 litre EST	MC6	92024162	BLACK with grey band
	M40	92024163	BLACK with violet band
	M76	92024160	BLACK with opaline green band
3.3 litre EFI	M40	92024161	BLACK with sky blue band
5.0 litre	M40	92015876	DARK GREEN with white band

2. UNIVERSAL JOINTS

On VK Series models, with the EFI engine, the propeller shaft is fitted with universal joints the same as used on 5.0 litre models.

For service operations refer to Section 04 of the VB Commodore Service Manual Part No. M38145.

The phasing of the front and rear yokes on propeller shafts fitted to 3.3 litre models, has changed from parallel to 90° apart.

SECTION 5

BRAKES

INDEX

Ref.	Subject	Page	Ref.	Subject	Page
1.	GENERAL INFORMATION	5-1	2.2	BRAKE BOOSTER	5-2
1.1	SERVICE NOTES	5-1		Remove	5-2
1.2	BRAKE BOOSTER - 6 CYLINDER	5-1		Reinstall	5-3
2.	SERVICE OPERATIONS	5-2	3.	SPECIFICATIONS	5-4
2.1	BRAKE FLUID CHANGE	5-2	4.	TORQUE WRENCH SPECIFICATIONS	5-4

1. GENERAL INFORMATION

With the exception of a non-serviceable brake booster and modified brake pipes to suit master cylinder position

on all 6 cylinder VK models, the brake system for VK is similar to VH models.

1.1 SERVICE NOTES

The polyglycol brake fluid used in VK Series models is hygroscopic and absorbs moisture from the air through the brake hoses etc. The boiling resistance of the fluid decreases as the moisture content increases and so the possibility of a vapour lock under heavy braking conditions increases with the age of the fluid. Therefore, for maximum brake effectiveness, a two yearly change of brake fluid is mandatory.

To prevent the absorption of moisture from the air, it is recommended that the brake fluid be stored in small (500 ml) containers and that any surplus fluid remaining in a container after use be discarded.

NOTE: The approved brake fluid (GMH Specification HN1796) is available from GM P & A in 500 ml containers under part number 92018952 and 250 ml containers, part number 92018951. If pressure bleeding equipment is used, it must be of an approved type with a diaphragm separating the brake fluid from the air.

CAUTION: Brake fluid is extremely damaging to paint. If fluid should accidentally touch a painted surface, immediately wash from paint and clean painted surface.

1.2 BRAKE BOOSTER - 6 CYLINDER

A single diaphragm brake booster is fitted to all 6 cylinder VK models. The brake booster is similar to that used on JB Camira models. The booster cannot be serviced and must be replaced if defective.

5-2 BRAKES

2. SERVICE OPERATIONS

2.1 BRAKE FLUID CHANGE

1. Thoroughly clean master cylinder especially around wheel brake line connections.
2. Disconnect wheel brake lines from master cylinder and remove reservoir cap.
3. Allow master cylinder to drain, until empty. (Refer Fig. 5-1).
4. Fill master cylinder reservoir with fresh, specified brake fluid from a sealed 500 ml container and **ensure reservoir is at least half full for remainder of procedure.**
5. Allow fluid to flow from open connection ports until fluid is free of air.
6. Reconnect wheel brake pipes to master cylinder and tighten to torque specified at end of section.
7. Bleed at each wheel using diaphragm type pressure bleeding equipment, until fluid removed is free of air.

NOTE: If pressure equipment is not available, proceed to bleed brake system manually (at least 6 pumps per wheel brake).

8. Loosen left hand caliper bleed screw.
9. Remove left hand caliper anchor plate retaining bolts. (See Fig. 5-2).
10. Hold caliper upside down and remove bleed screw to drain contents of caliper into suitable receptacle.
11. Hand tighten bleed screw and reinstall caliper assembly.
12. Tighten anchor plate retaining bolts to torque specified at end of section.
13. Repeat step 8 to 12 for right hand caliper assembly.
14. Bleed front calipers.

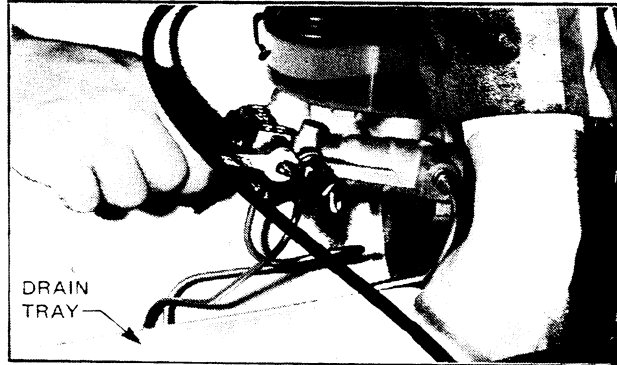

Figure 5-1

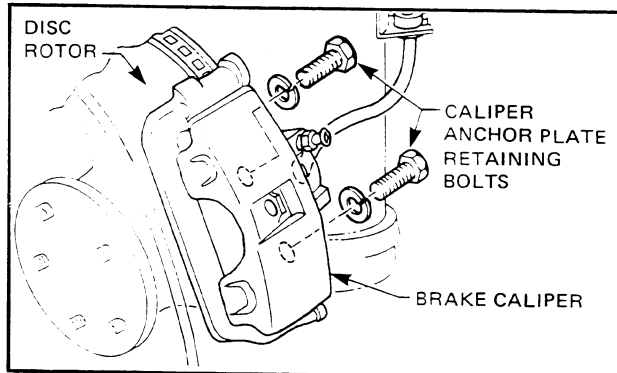

Figure 5-2

2.2 BRAKE BOOSTER

REMOVE

1. Disconnect electrical lead and three brake pipes from master cylinder. (Refer Fig. 5-3).
2. Unscrew nuts securing master cylinder support bracket to adjacent spring tower. (Refer Fig. 5-3).
3. Remove master cylinder to bracket bolt and remove bracket. (Refer Fig. 5-3).
4. Remove nuts securing master cylinder to power booster studs. (Refer Fig. 5-3).
5. Remove master cylinder taking care not to disturb power booster push rod.

NOTE: Do not depress brake pedal with master cylinder removed or reaction disc may become dislodged in booster.

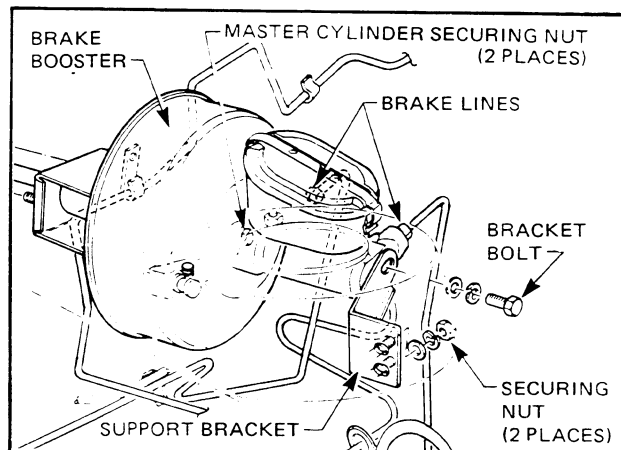

Figure 5-3

6. Remove vacuum hose from brake booster body.
7. Remove two brake booster assembly retaining nuts at brake pedal support, from inside the vehicle. (Refer Fig. 5-4).

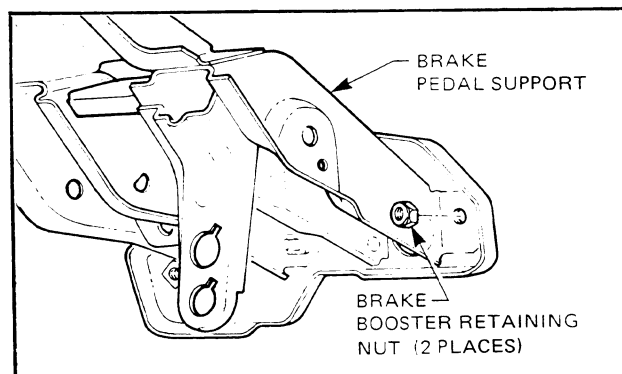

Figure 5-4

8. Remove brake push rod retaining clip and washer from brake pedal and lift push rod off brake pedal stud. (Refer Fig. 5-5)
9. Withdraw booster assembly from engine compartment. Remove bracket and gasket from booster studs.

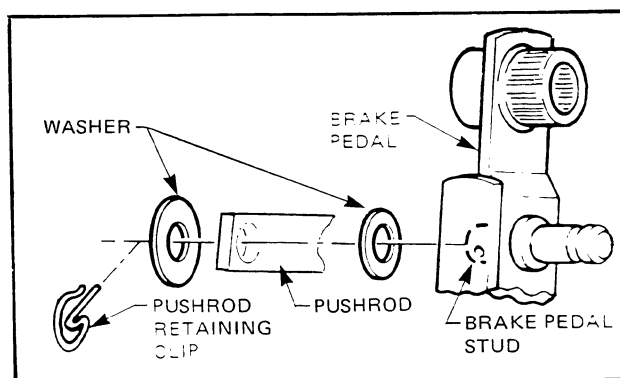

Figure 5-5

REINSTALL

1. Locate bracket and gasket on booster studs.
2. Place booster assembly in position and fit push rod over brake pedal stud. Refit washer and clip to stud.
3. Reinstall two booster retaining nuts and tighten to torque specified in rear of Section.
4. Refit vacuum hose to booster body.
5. Carefully position master cylinder over power booster push rod and retaining studs and torque retaining nuts to torque specified at end of this Section. Resecure support bracket to spring tower and master cylinder.
6. Tighten all bolts to torques specified at end of this Section. Bleed brake system. If pressure bleeding is employed, the brake lines must be reconnected to master cylinder before commencing bleeding procedure.

5-4 BRAKES

3. SPECIFICATIONS

Brake Fluid	GM Specification HN1796 (GM P & A Part No. 92018952 - 500 mls) 92018951 - 250 mls)
Brake Booster Assembly	
Type	Single Vacuum Suspended
Vacuum Piston Diameter	230 mm

4. TORQUE WRENCH SPECIFICATIONS

	Nm
Brake Booster Retaining Nuts	20 – 25
Master Cylinder to Bracket Bolt	15 – 18
Master Cylinder Bracket to Panel Nuts	20 – 25
Master Cylinder to Brake Booster	19 – 28
Pressure Differential Warning Switch	1.4 – 1.8
Caliper Anchor Plate Retaining Bolts	70 – 85
Brake Pipes to Master Cylinder Nuts	8 – 11

SECTION 6A

ENGINE MECHANICAL

INDEX

Ref.	Subject	Page	Ref.	Subject	Page
1.	GENERAL DESCRIPTION	6A-1	2.3	CYLINDER HEAD (EFI)	6A-5
1.1	3.3 LITRE ENGINE WITH ELECTRONIC SPARK TIMING (EST)	6A-2		Remove	6A-5
1.2	3.3 LITRE ENGINE WITH ELECTRONIC FUEL INJECTION (EFI)	6A-3	2.4	ENGINE ASSEMBLY (EST)	6A-7
	Inlet Manifold	6A-4		Remove	6A-7
	Exhaust System	6A-4	2.5	ENGINE ASSEMBLY (EFI)	6A-8
2.	SERVICE OPERATIONS	6A-4		Remove	6A-8
2.1	COMPRESSION TEST	6A-4		Reinstall	6A-13
2.2	CYLINDER HEAD (EST)	6A-5	3.	TORQUE WRENCH SPECIFICATIONS.....	6A-13
	Remove.....	6A-5			

1. GENERAL DESCRIPTION

Three different engines are released for use with VK Series models.

A 3.3 litre engine equipped with Electronic Spark Timing (EST) is standard equipment on SL and Berlina models.

A 3.3 litre engine with Electronic Fuel Injection (EFI) is standard on Calais and available as an option on all sedan models with automatic transmission.

The 5.0 litre V8 engine with automatic transmission, which carries over from the VH Series, is available as an option on all models.

The changes to the 3.3 litre engine have been introduced to reduce emissions and improve fuel economy. A summary of the modifications used for each 3.3 litre engine follows.

6A-2 ENGINE MECHANICAL

1.1 3.3 LITRE ENGINE WITH ELECTRONIC SPARK TIMING (EST)

This engine uses the Bosch Electronic Spark Timing system, refer Section 6D, Ignition System, of this Supplement for details.

Detailed revisions have been made to the following engine components, to suit the requirements of the EST engine.

The cylinder head and inlet valves incorporate changes to improve gas flow refer Figs. 6A-1 and 6A-2.

Cylinder head gasket, has a pigmented dark brown colour for identification, and is of a heavy duty construction.

Spark plugs, copper cored with thicker electrodes.

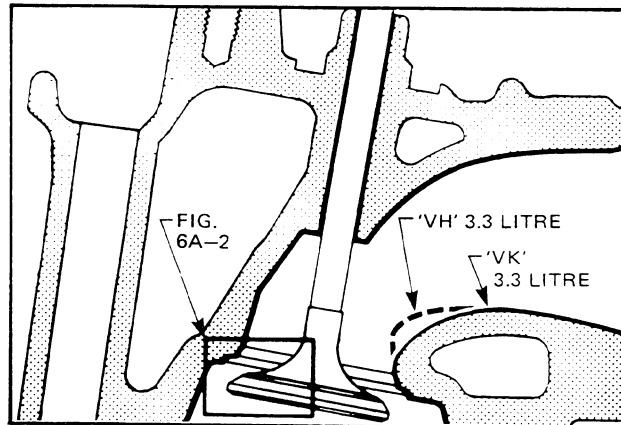

Figure 6A-1

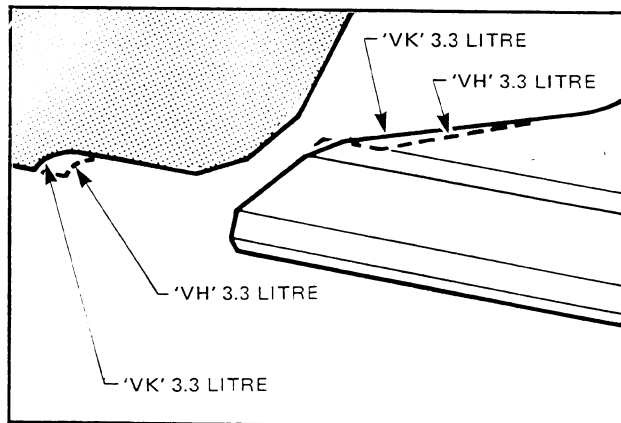

Figure 6A-2

The cylinder head is also revised to accept the air pump type Air Injection Reactor system. The cylinder block has been modified at the rear to accept the mounting of the EST speed sensor, refer Fig. 6A-3

The flywheel and torque converter assemblies have three timing pins added around their circumference. There is also a dowel pin added to the rear face of the crankshaft to accurately locate the flywheel or automatic drive plate. Pistons have been revised to suit the engine operating characteristics.

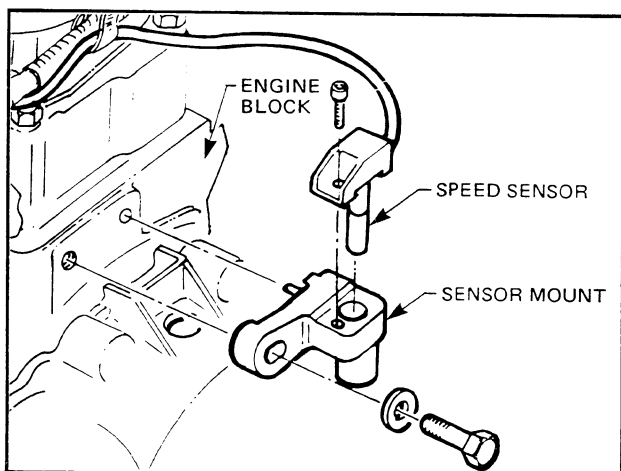

Figure 6A-3

1.2 3.3 LITRE ENGINE WITH ELECTRONIC FUEL INJECTION (EFI)

This engine uses the Bosch LE-2 Jetronic Fuel Injection system. Refer Section 6C of this Supplement for details. Detailed revisions have been made to the following engine components, to suit the requirements of the EFI engine.

The cylinder head and inlet valves incorporate changes to improve gas flow. Refer Figs. 6A-4 and 6A-5.

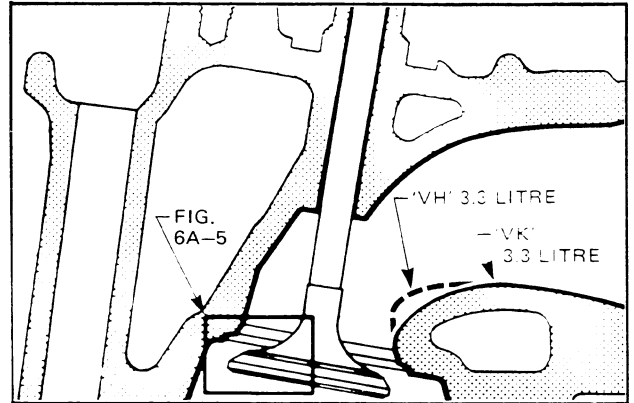

Figure 6A-4

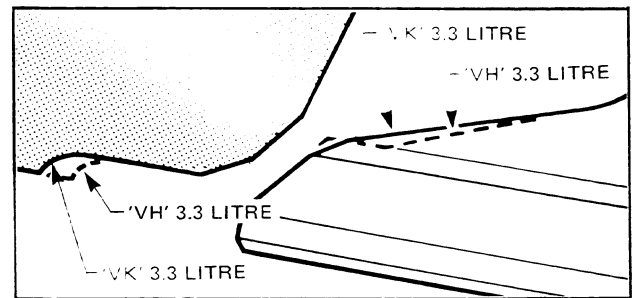

Figure 6A-5

Spark plugs, copper cored with thicker electrodes.

Exhaust valves, with improved material specifications, are identified by a forged 'S' in the valve head recess. Refer Fig. 6A-6.

Cylinder head gasket, has a pigmented dark brown colour for identification, and is of a heavy duty construction.

Camshaft: Cam profiles have been revised. For valve timing details refer chart below.

NOTE: Timing includes ramps. Opening ramp 26°
Closing ramp 32°.

		Including Ramps
Inlet Valve	Opens BTC	46°
	Closes ABC	108°
	Duration	334°
Exhaust Valve	Opens BTC	86°
	Closes ATC	68°
	Duration	334°
Valve Open Overlap		114°

Pistons have been revised to suit the engine operating characteristics.

Timing Gears: Revised gear tooth design for camshaft drive gear set and improved material for steel crankshaft gear.

The timing case cover has been modified with the addition of an oil redirection rib (Fig. 6A-7). This allows additional oil flow to the timing gears.

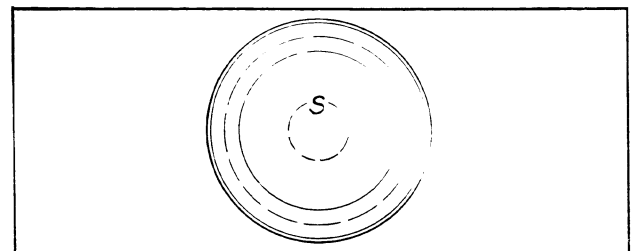

Figure 6A-6

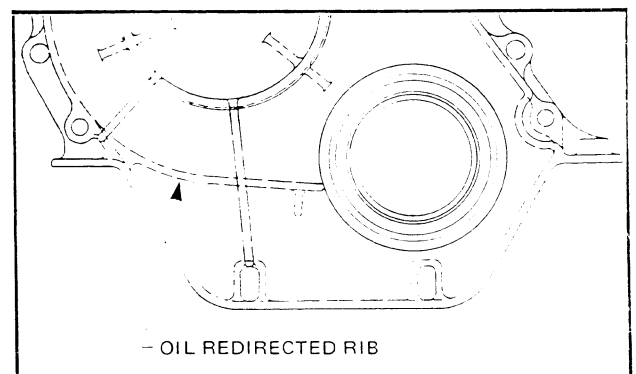

Figure 6A-7

6A-4 ENGINE MECHANICAL

INLET MANIFOLD

A new ram tuned inlet manifold is used to optimise mid range torque. It has the diameter and length of the runners tuned so that a positive pressure pulse arrives at the inlet valve just prior to its closing. This forces extra air into the cylinder giving a pressure charging effect which can be as high as 15 kPa.

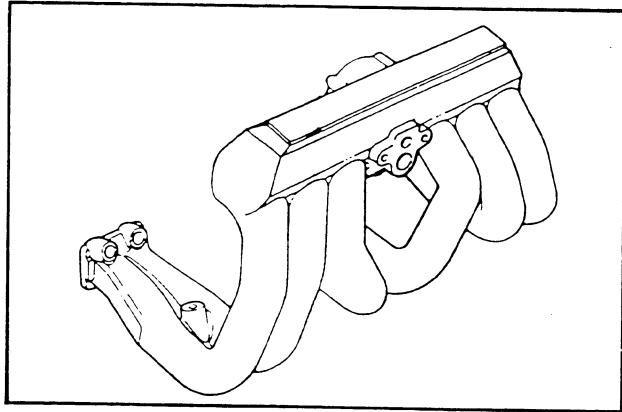

Figure 6A-8

EXHAUST SYSTEM

A substantial power and torque increase has been achieved by the use of exhaust extractors in conjunction with a single exhaust system.

The exhaust extractors, which are manufactured from stainless steel, have a low heat retention, helping to minimise under hood temperatures.

For further details of the exhaust system, refer to Section 8B of this Supplement.

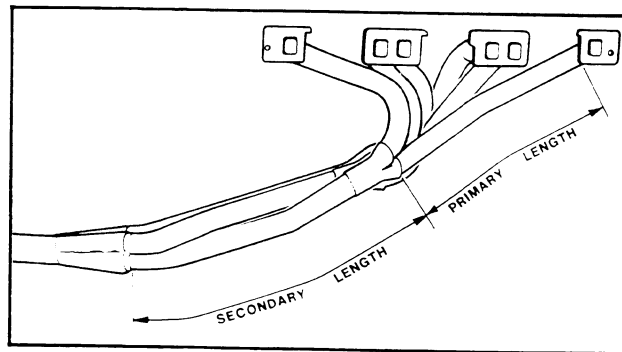

Figure 6A-9

2. SERVICE OPERATIONS

For service and overhaul operations not listed in this Supplement, refer to the Improved Performance L6 and V8 Engine Service Manual, Part No. M38388.

2.1 COMPRESSION TEST

On EFI equipped vehicles, the control relay must be removed from the fuse box (refer Fig. 6A-10), before commencing a compression test, to prevent the injection of fuel which may be blown out the spark plug holes.

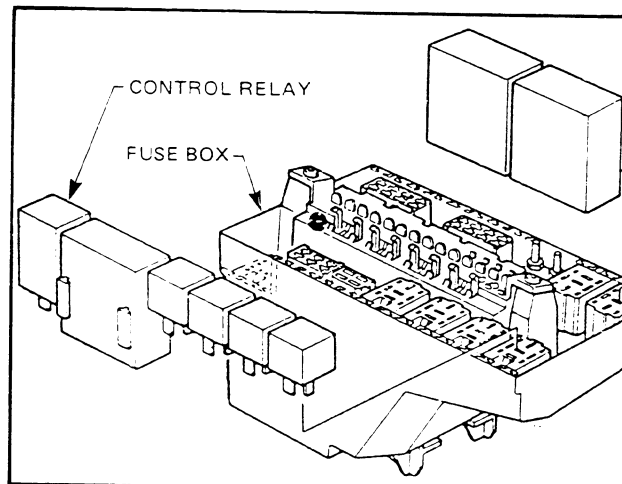

Figure 6A-10

2.2 CYLINDER HEAD (EST)

REMOVE

Removal procedures for the cylinder head on an engine equipped with EST are the same as for a VH L6 model with the air pump type Air Injection Reactor system.

The only additions are the disconnection and removal of wiring at the throttle position switch, coolant temperature sensor and engine speed sensor, refer Fig. 6A-11.

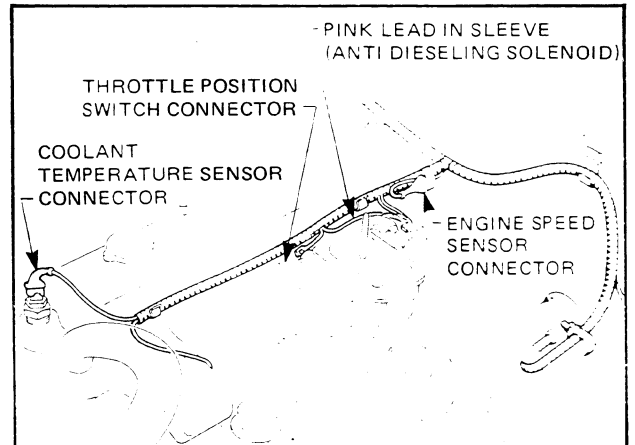

Figure 6A-11

2.3 CYLINDER HEAD (EFI)

REMOVE

1. Disconnect battery earth lead. Carry out removal operations outlined in 3.9 'Air Flow Duct' and 3.11 'Inlet Manifold' in Section 6C 'Fuel Injection' of this Supplement.
2. Secure exhaust extractors away from the cylinder head.
3. Remove the radiator pressure cap, drain the radiator by removal of lower radiator hose.

CAUTION: If the cooling system is hot, the radiator cap must not be removed quickly - it should be rotated slowly to the first stop, which permits the pressure in the system to release slowly through the overflow pipe. The cap must not be removed completely until all escape of steam has ceased, or there is a danger of water or steam scalding the operator. Do not tilt the cap during rotation to the first stop or some steam may escape through the top of the radiator neck instead of through the overflow pipe.

4. Remove top radiator and heater hoses.
5. Depressurize fuel system as per 3.2 'Depressurize' Section 6C of this supplement.
6. Remove fuel return line mounting bolts from rocker cover and engine side plate. Refer Fig.6A-12.
7. Disconnect fuel return line from flexible fuel hose and plug open end with a suitable plug.
8. Disconnect electrical connector from auxiliary air valve.

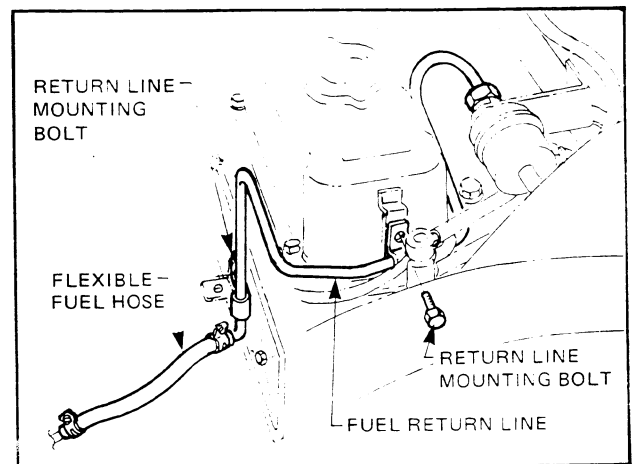

Figure 6A-12

6A-6 ENGINE MECHANICAL

9. Disconnect throttle cable from mounting bracket. Refer Fig. 6A-13.

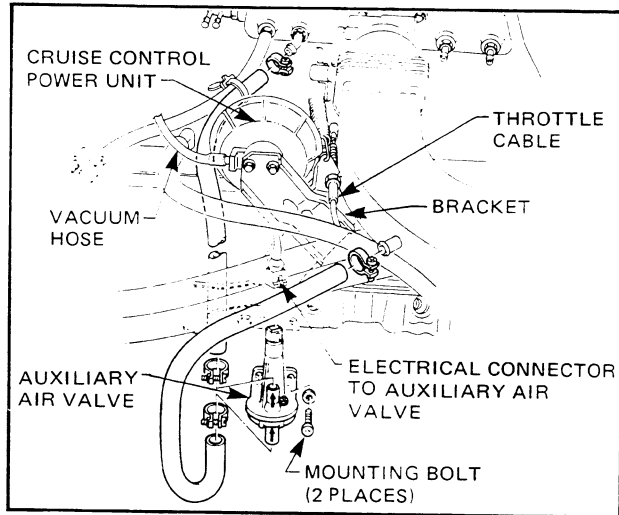

Figure 6A-13

10. Remove fuel hoses from fuel damper, plug with suitable plugs. Refer Fig. 6A-14.
11. Remove cruise control power unit bracket mounting to cylinder head bolts and remove bracket assembly. Refer Fig. 6A-14.
12. Disconnect high tension wires and remove spark plugs, disconnect coil positive and negative wires and remove coil attaching bolt and coil.
13. If fitted with air conditioning, loosen drive belt idler pulley and disconnect drive belt.

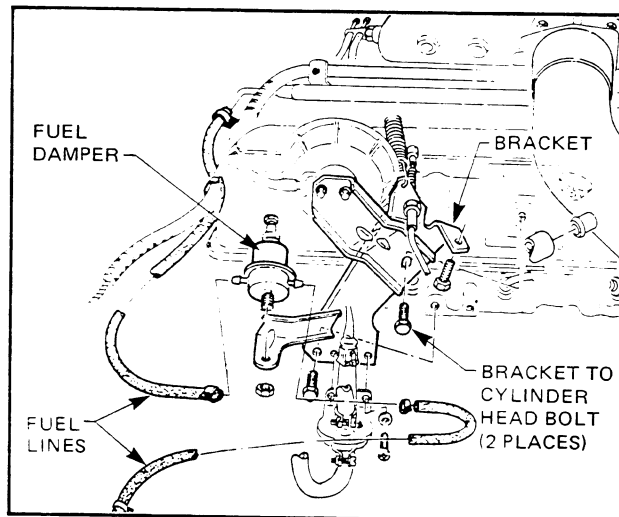

Figure 6A-14

14. Remove compressor mounting and bracket bolts and position compressor and bracket away from the cylinder head. Refer Fig. 6A-15.

NOTE: Do not bend metal pipes at compressor. This could lead to fracture of the pipes.

15. Remove the ventilation valve, valve rocker cover attaching bolts, the cover and gasket.
16. Remove rocker arm pivot bolts, rocker arm pivot, rocker arms and push rods.

NOTE: Remove each set (one set per cylinder) as a unit. It is important that the original location of all pivots and arms is retained on assembly. For this purpose, parts should be placed in a special rack, Tool No. 6A35.

17. Remove the cylinder head bolts, cylinder head and gasket. Place cylinder head on two blocks of wood to prevent damage.

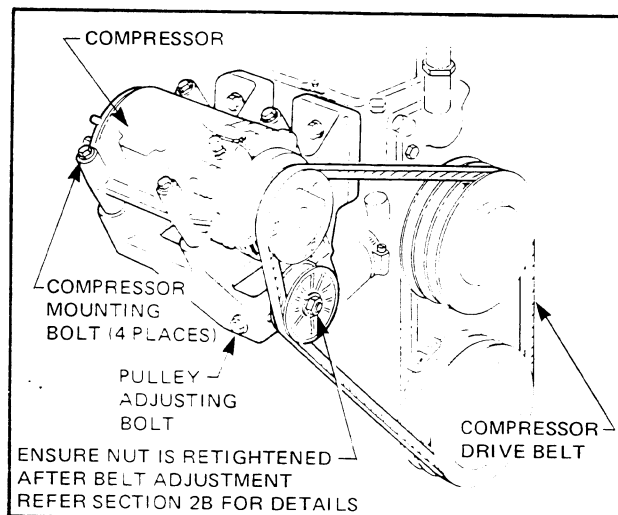

Figure 6A-15

REINSTALL

Installation is reversal of removal instructions. However, additional 'Service Operations', 'Cleaning and Inspection' as described in the Improved Performance L6 and V8 Engine Service Manual, Part No. M38388, must be carried out.

Attention must also be paid to the following items.

Correct adjustment of the throttle cable and cruise control power unit cable, Service Operations 3.3 and 3.4, Section 6C, 'Fuel Injection', of this Supplement.

Check for fuel leaks as described in Service Operation 3.2 'Leak Testing', Section 6C, 'Fuel Injection' of this Supplement.

2.4 ENGINE ASSEMBLY (EST)

REMOVE

1. Removal procedures for a 3.3 litre engine equipped with EST are the same as for VH L6 models with the air pump type Air Injection Reactor system.
2. The only additions are, the removal of wiring connections at the throttle position switch, coolant temperature sensor and engine speed sensor. Refer Fig. 6A-16.

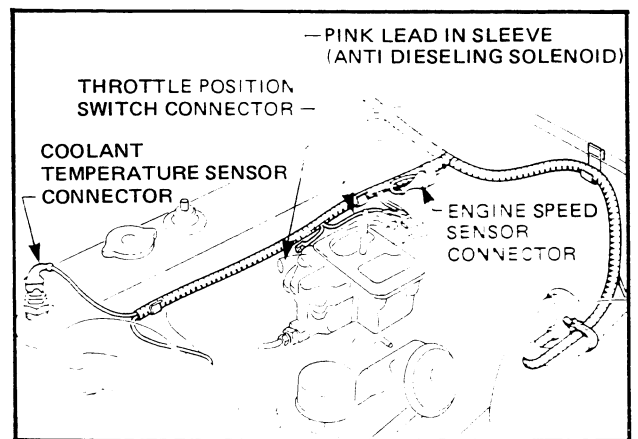

Figure 6A-16

NOTE: The speed sensor must be removed from the rear of the cylinder block before separating the cylinder block and the transmission. Refer Fig. 6A-17.

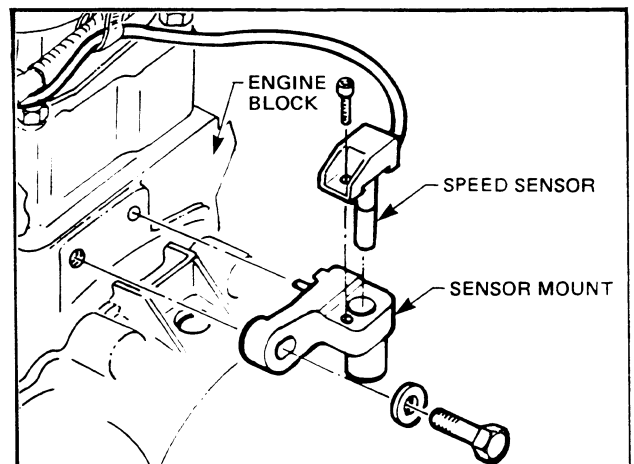

Figure 6A-17

6A-8 ENGINE MECHANICAL

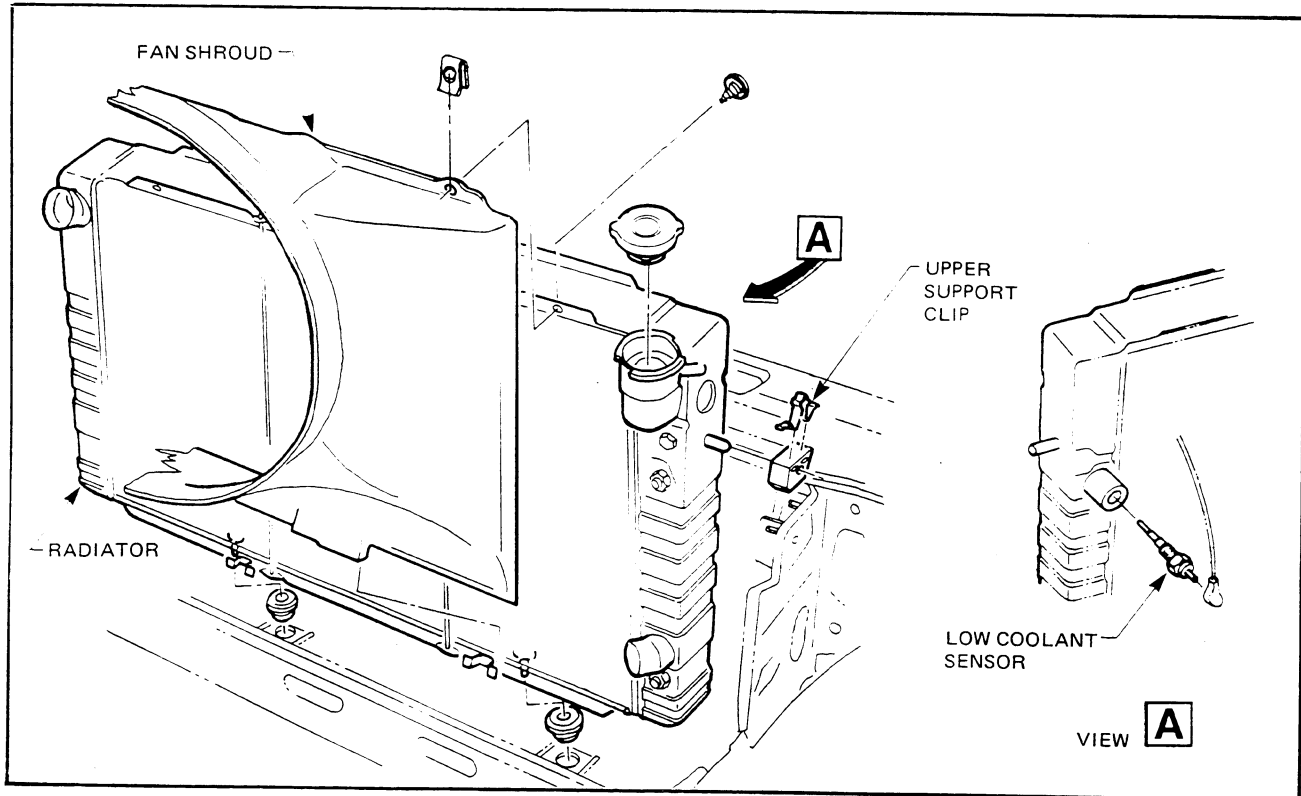

Figure 6A-18

2.5 ENGINE ASSEMBLY (EFI)

REMOVE

1. Disconnect battery earth lead.
2. Remove bottom radiator hose and drain cooling system. Remove top radiator hose. Disconnect automatic transmission cooler lines from radiator.
3. Disconnect radiator fan shroud from radiator. Remove upper radiator support clips, lift up radiator. From the front of the radiator, disconnect the low coolant sensor wire, if so equipped. Refer Fig. 6A-18.
4. Remove radiator, taking care not to damage low coolant sensor, remove shroud.
5. Drain oil pan.
6. Remove air flow duct as per Service Instruction 3.9, Section 6C 'Fuel Injection' of this Supplement.
7. Remove engine hood.
8. Loosen generator, and if fitted, power steering pump, air conditioning compressor and remove drive belts. Refer Fig. 6A-19.
9. Disconnect brake booster vacuum hose from inlet manifold.

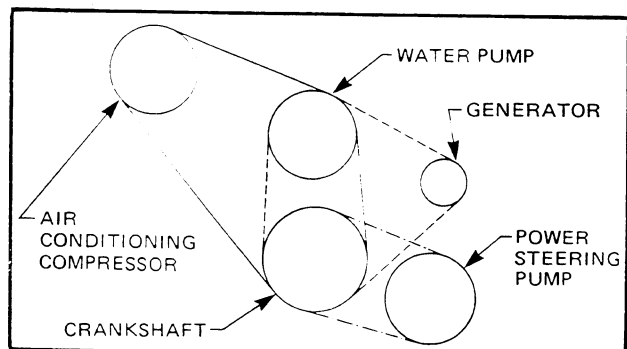

Figure 6A-19

ENGINE MECHANICAL 6A-9

10. Disconnect cannister to throttle body purge hose, from cannister. Refer Fig. 6A-20.

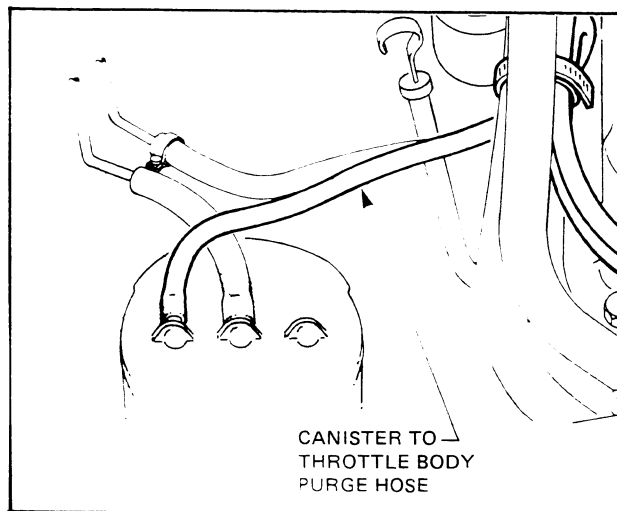

Figure 6A-20

11. Remove four retaining bolts from the cooling fan assembly, remove fan and associated parts. Fig. 6A-21.

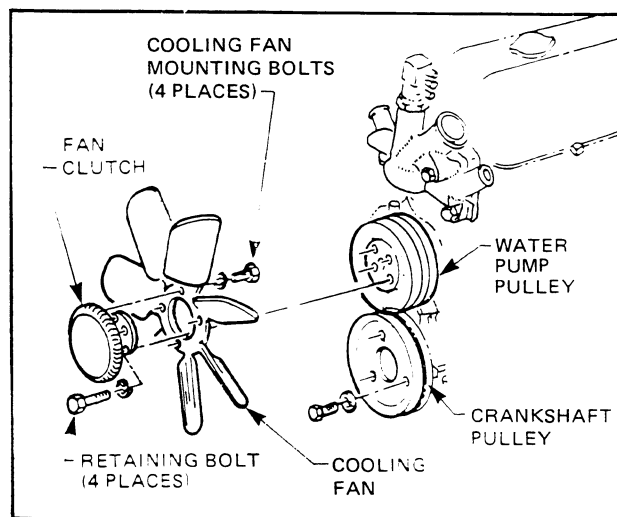

Figure 6A-21

12. On models with air conditioning, remove the compressor and mounting bracket from its position (refer Fig. 6A-22) and support it out of the way without disconnecting the hoses.

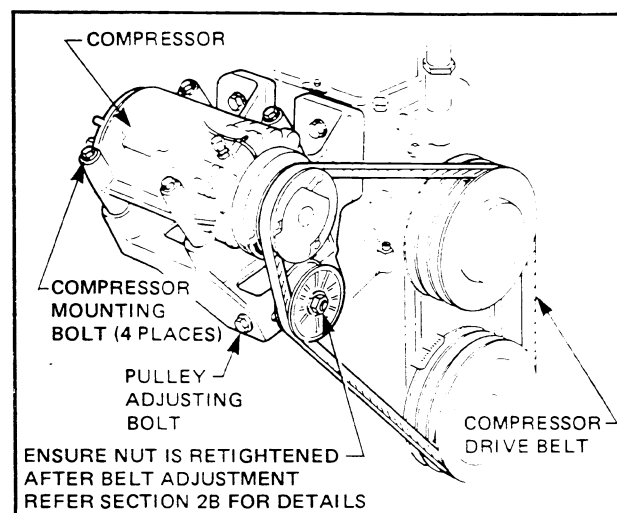

Figure 6A-22

6A-10 ENGINE MECHANICAL

13. Remove power steering pump mounting and adjusting bolts (refer Fig. 6A-23) and support pump out of the way without disconnecting the hoses.
14. Disconnect heater hoses from engine.

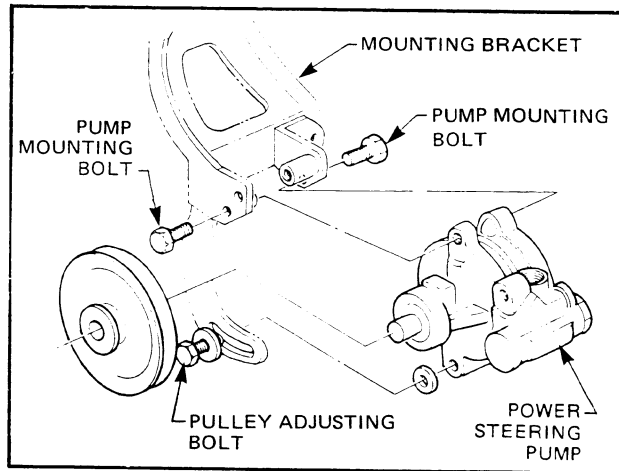

Figure 6A-23

15. Disconnect wiring harness connections from starter motor, generator and engine earth from generator bracket. Refer Fig. 6A-24.

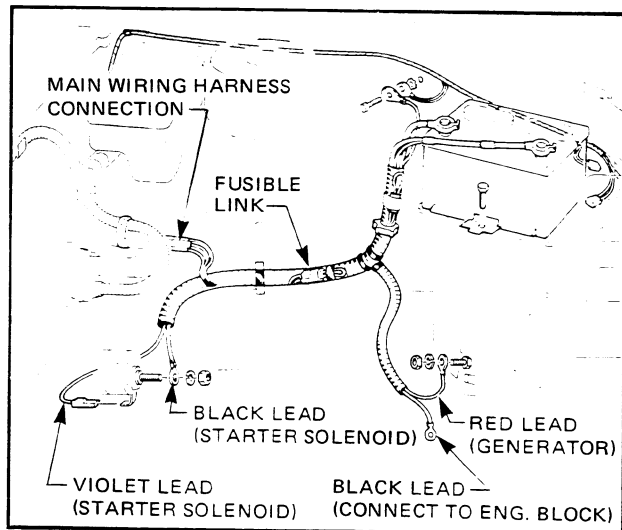

Figure 6A-24

16. Disconnect wiring connections at oil pressure sender unit, coolant temperature sender, ignition coil and auxiliary air valve. Refer Fig. 6A-25.

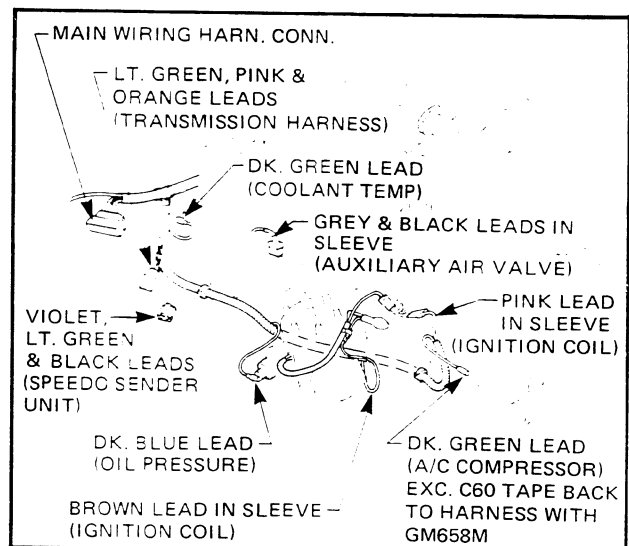

Figure 6A-25

ENGINE MECHANICAL 6A-11

17. Disconnect auxiliary air valve hose from inlet manifold. Disconnect throttle cable from bracket, and if so equipped, cruise control power unit cable from throttle body and vacuum hose from vacuum adaptor as rear of inlet manifold. Refer Fig. 6A-26.
18. Depressure fuel system as per 3.2 'Depressurize', Section 6C, of this Supplement.
19. Remove fuel lines from fuel damper and plug with suitable plugs.

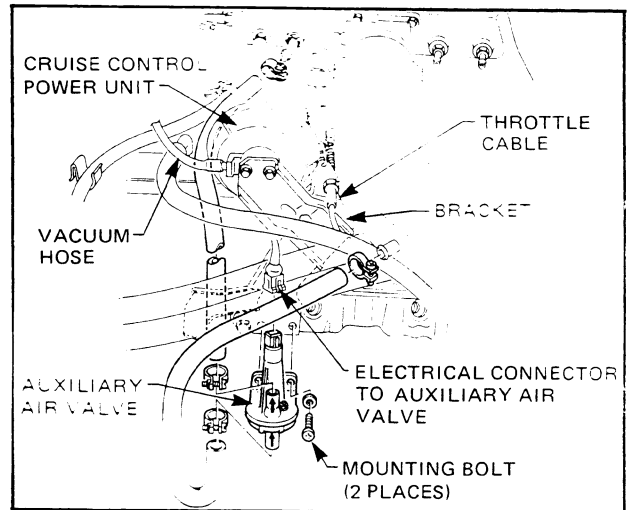

Figure 6A-26

20. Remove bracket mounting to cylinder head bolts and remove bracket assembly. Refer Fig. 6A-27.

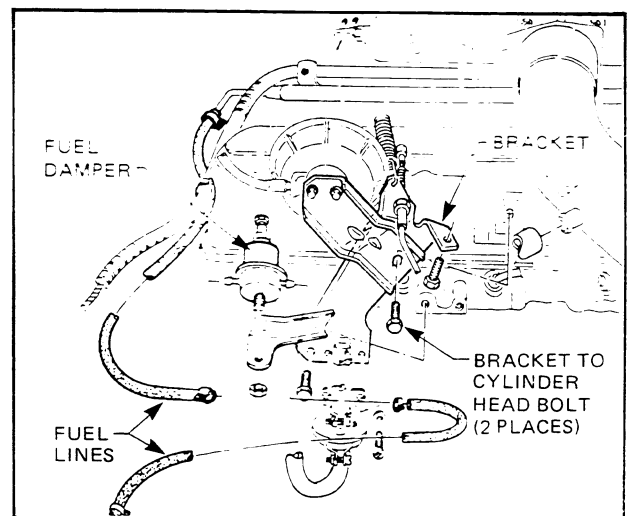

Figure 6A-27

21. Remove wiring connectors from fuel injectors, throttle position switch, coolant temperature sensor. Refer Fig. 6A-28. To avoid damage, do not pull on wires at the connectors.
22. Remove flexible fuel hose from fuel return line at engine side plate.

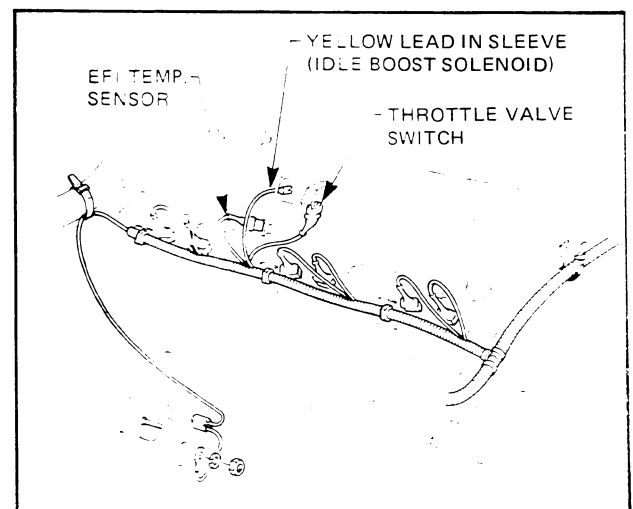

Figure 6A-28

6A-12 ENGINE MECHANICAL

23. Plug open end of flexible fuel hose with a suitable plug. Refer Fig. 6A-29.

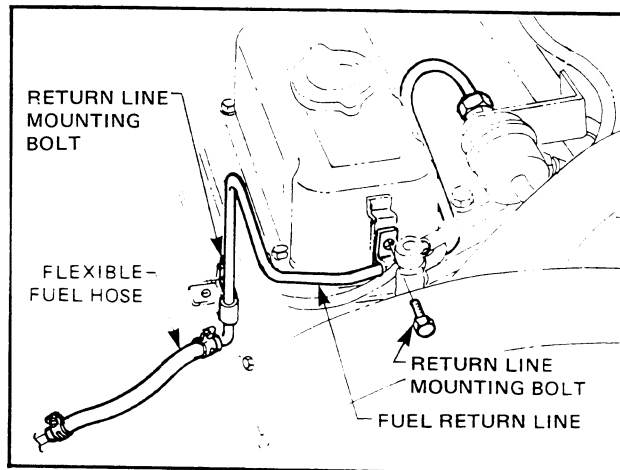

Figure 6A-29

24. Remove vacuum hoses from vacuum adaptor at the rear of the inlet manifold, remove adaptor. Refer Fig. 6A-30.
25. Raise the vehicle and place on jack stands.
26. Disconnect the gear shift from the transmission, refer to VB Commodore Service Manual, Clutch and Transmission Section.
27. Remove the speedometer cable from the extension housing, or if fitted, disconnect speed sensor wires at the extension housing. Disconnect detent solenoid wire and TCS switch from the transmission.
28. Remove tailshaft and insert a protector in the end of the transmission extension housing to prevent loss of fluid.

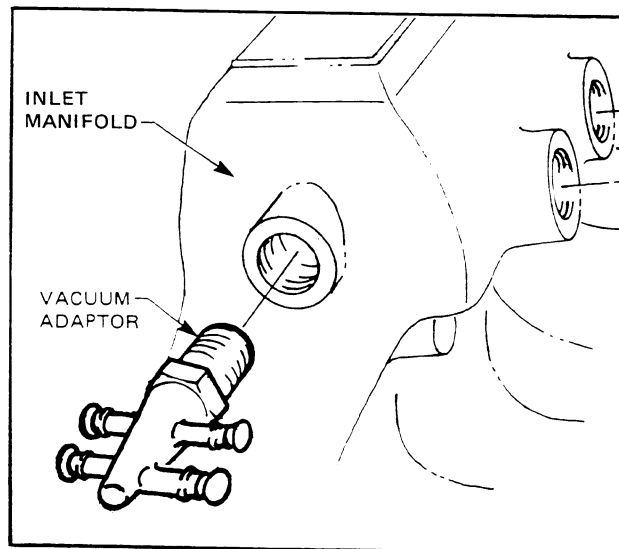

Figure 6A-30

29. Install Tool No. 6A37 engine lifting hook or equivalent, raise engine slightly and remove the front engine mounting to crossmember bracket through bolts. Refer Fig. 6A-31.

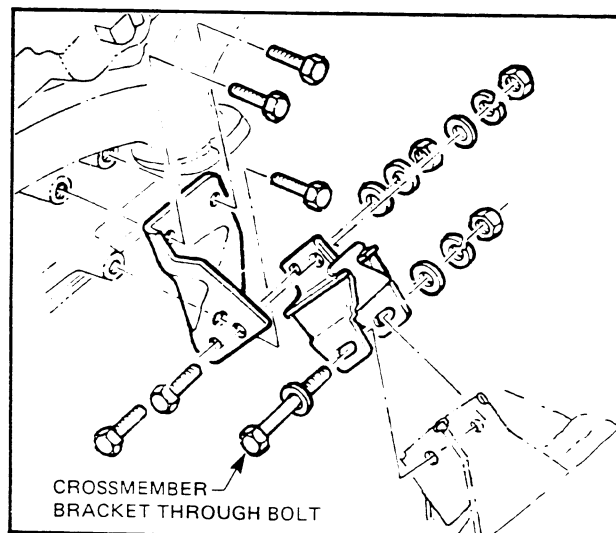

Figure 6A-31

30. Disconnect exhaust system from exhaust extractors. Refer Fig. 6A-32.
31. Remove engine rear crossmember.
32. Raise the engine with the front tilted upwards and lift the engine and transmission out of the vehicle.

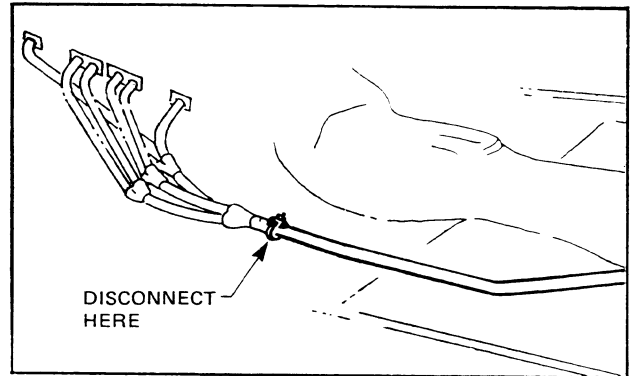

Figure 6A-32

REINSTALL

1. Installation is reversal of removal.
2. Refer Section 6C, 'Fuel Injection' in this Supplement for correct hose and electrical connections.
3. Add recommended oil and coolant.
4. Check fuel system for leaks as described in service operation 3.2 'Leak Testing' Section 6C, 'Fuel Injection', in this Supplement.
5. Start engine, check and adjust ignition timing, and for full throttle opening, check for air leaks.
6. Check for oil and coolant leaks.

3. TORQUE WRENCH SPECIFICATIONS

	Nm
Engine Speed Sensor to Cylinder Block Bolt	30 – 40
Cylinder Head to Cylinder Block	54 (first torque) 102 (final torque)
Rocker Arm Pivot to Cylinder Head	30 – 38
Rocker Cover to Cylinder Head	3 – 6
Fuel Return Line Mounting Bolts	8 – 10
Fuel Return Line to Pressure Regulator Nut	25 – 30
Air Flow Duct Mounting Bolt	8 – 11
Air Flow Duct Mounting Bracket to Cylinder Head Bolt	20 – 27
Air Conditioning Compressor Mounting Bolts	20 – 27
Compressor Bracket Bolts	40 – 54
Alternator Mounting Nut	20 – 25
Alternator Adjusting Bolt	12 – 16
Power Steering Pump Mounting & Adjusting Bolts	40 – 51
Cooling Fan Retaining Bolts	27 – 36
Engine Mounting Nuts	34 – 46
Rear Transmission Mounting Bolts	34 – 46
Rear Crossmember Mounting Bolts	40 – 50
Exhaust Clamp Nuts	24 – 32

SECTION 6B

ENGINE COOLING

INDEX

Ref.	Subject	Page	Ref.	Subject	Page
1.	GENERAL DESCRIPTION	6B-1	2.1	RADIATOR OVERFLOW/WINDSHIELD WASHER BOTTLE	6B-1
2.	SERVICE OPERATIONS	6B-1		Remove	6B-1
				Reinstall	6B-1
			2.2	COOLING SYSTEM - FLUSH SYSTEM	6B-2

1. GENERAL DESCRIPTION

The cooling system employed on VK Series models is carried over from VH, with only a few minor changes.

The radiator overflow/windscreen washer bottle has been redesigned and repositioned (Fig. 6B-1).

All VK 3.3 litre engines have the thermostat housing, fan pulleys and fan belt from the L6 2.8 litre VH engine.

2. SERVICE OPERATIONS

Service operations are as described in the VB and VH Series Service Manuals, except where noted in this Section.

2.1 RADIATOR OVERFLOW/WINDSHIELD WASHER BOTTLE

REMOVE

1. Remove radiator overflow cap from bottle.
2. Disconnect windshield washer hose and electrical connector from washer pump.
3. Remove two mounting screws (Fig. 6B-1) and lift bottle assembly out from its position.

REINSTALL

1. Installation is reversal of removal.
2. Fill the radiator overflow bottle up to the required level, as indicated by the mark on the outside of the bottle.
3. Fill up windshield washer bottle and test washer operation.

6B-2 ENGINE COOLING

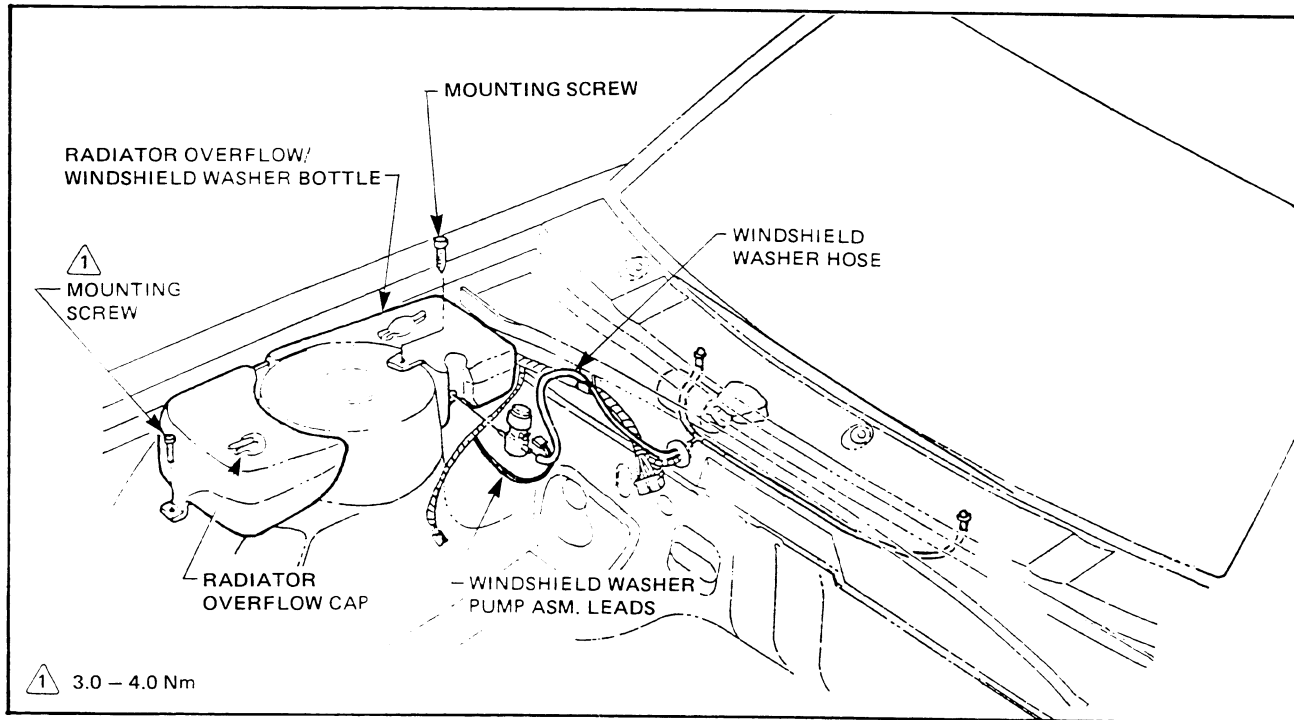

Figure 6B-1

2.2 COOLING SYSTEM - FLUSH SYSTEM

1. Place drain tray under vehicle.
2. Remove top radiator hose from thermostat housing.
3. Remove thermostat housing and thermostat.
4. Place water hose into the top radiator hose, turn on water pressure, and flush until water coming from cylinder head is clear.
5. Flush heater core by removing top heater hose from thermostat housing and flush until clear.
6. Flush radiator by removing bottom radiator hose from water pump and flush until clear.
7. Remove overflow bottle, as per service operation 2.1, and flush.
8. With the system flushed clean, replace thermostat housing gasket and refit all cooling system components. Mix a coolant concentration of approximately 21 mls of corrosion inhibitor, GMH Specification HN1109, with every litre of clean water. Add to the cooling system and check for leaks.

SECTION 6C

ENGINE FUEL

CONTENTS OF THIS SECTION

Subject	Page
ELECTRONIC FUEL INJECTION.....	6C-1
CARBURETTOR (3.3 EST).....	6C-67
5.0 LITRE ENGINE FUEL SYSTEM	6C-87

ELECTRONIC FUEL INJECTION

INDEX

Ref.	Subject	Page	Ref.	Subject	Page
1.	GENERAL DESCRIPTION.....	6C-2	3.11	INLET MANIFOLD	6C-35
1.1	MAIN COMPONENT SYSTEMS	6C-2		Remove.....	6C-35
	Air Flow System.....	6C-2		Reinstall	6C-37
	Fuel System.....	6C-3	3.12	AUXILIARY AIR VALVE	6C-37
	Electrical System	6C-5		Remove.....	6C-37
1.2	FUNCTION OF MAIN COMPONENT			Reinstall	6C-37
	SYSTEMS	6C-8		Test	6C-37
	Air Flow System.....	6C-8	3.13	FUEL PUMP.....	6C-38
	Fuel System.....	6C-8		Remove.....	6C-38
	Electrical System	6C-8		Reinstall	6C-38
2.	PRINCIPLES OF OPERATION	6C-12		Testing	6C-38
2.1	FUEL INJECTION TIMING	6C-12	3.14	FUEL DAMPER - REAR	6C-40
2.2	FUEL INJECTION QUANTITY	6C-12		Remove.....	6C-40
2.3	ENRICHMENTS	6C-12		Reinstall	6C-40
	Enrichment Sensors	6C-12	3.15	FUEL FILTER	6C-40
	Acceleration Enrichment	6C-12		Remove.....	6C-40
	Full Throttle (High Load)			Reinstall	6C-40
	Enrichment.....	6C-14	3.16	FUEL DAMPER - FRONT	6C-40
2.4	FUEL SHUT OFF - COASTING	6C-14		Remove.....	6C-40
2.5	VOLTAGE CORRECTION FUNCTION	6C-14		Reinstall	6C-40
2.6	COMPONENT OPERATION	6C-14	3.17	FUEL RAIL	6C-41
	Air Flow system	6C-14		Remove.....	6C-41
	Fuel System.....	6C-17		Reinstall	6C-42
	Electrical System	6C-20	3.18	INJECTORS	6C-42
3.	SERVICE OPERATIONS	6C-24	3.19	PRESSURE REGULATOR.....	6C-42
3.1	SERVICE NOTES	6C-24		Remove.....	6C-42
3.2	FUEL SYSTEM	6C-24		Reinstall	6C-42
	Leak Testing	6C-24	3.20	CONTROL UNIT	6C-42
	Depressurizing	6C-24		Remove.....	6C-42
	Fuel Hoses and Clamps	6C-25		Reinstall	6C-43
3.3	THROTTLE CABLE ADJUSTMENT.....	6C-26	3.21	THROTTLE POSITION SWITCH	6C-43
3.4	CRUISE CONTROL POWER UNIT CABLE			Remove.....	6C-43
	ADJUSTMENT	6C-26		Reinstall	6C-43
3.5	ADJUSTING IDLE SPEED AND MIXTURE			Adjustment.....	6C-43
	Idle Speed Adjustment.....	6C-27	3.22	COOLANT TEMPERATURE SENSOR	6C-44
	Idle Mixture Adjustment.....	6C-27		Replace.....	6C-44
3.6	AIR CLEANER ELEMENT.....	6C-28		On Engine Test.....	6C-44
	Replacement	6C-28		Off Engine Test	6C-45
3.7	AIR CLEANER HOUSING	6C-29	3.23	CONTROL RELAY	6C-46
	Remove.....	6C-29		Remove.....	6C-46
	Reinstall	6C-30		Reinstall	6C-46
3.8	AIR FLOW METER.....	6C-30	4.	DIAGNOSIS	6C-47
	Remove.....	6C-30	4.1	CIRCUIT TESTING PROCEDURE	6C-47
	Reinstall	6C-31		Electronic Fuel Injection	
	Test	6C-32		Test Equipment	6C-47
3.9	AIR FLOW DUCT	6C-32	4.2	TROUBLE DIAGNOSIS	6C-61
	Remove.....	6C-32	5.	SPECIFICATIONS	6C-64
	Reinstall	6C-33	6.	TORQUE WRENCH SPECIFICATIONS.....	6C-65
3.10	THROTTLE BODY	6C-33	7.	SPECIAL TOOLS	6C-66
	Remove.....	6C-33			
	Reinstall	6C-34			

6C-2 ENGINE FUEL

1. GENERAL DESCRIPTION

The Electronic Fuel Injection (EFI) used on VK series vehicles is the Bosch LE-2 Jetronic system.

The LE-2 Jetronic is an electronically controlled fuel injection system which injects fuel at regular intervals into the inlet ports adjacent to the inlet valves. It provides a method of more precisely metering fuel to satisfy the various engine operating conditions.

In a carburettor type fuel system, the intake manifold design must strike a medium between low and high speed requirements for air flow. At idle, air flow is very low and in order to keep the fuel mixed with air, it is necessary to have small passages to keep up the air

velocity. When power is required, it is desirable to have as large a manifold passage as possible.

To supply both these requirements the manifold must be a compromise which results in passages of such a size which limits both low and high speed performance.

With EFI systems, the elimination of the carburettor enables the induction passages to be designed to optimize air flow and an increased engine performance can be expected with the resultant improvement in volumetric efficiency. Air is induced into the engine through the inlet manifold, and fuel is injected under pressure into the inlet valve port.

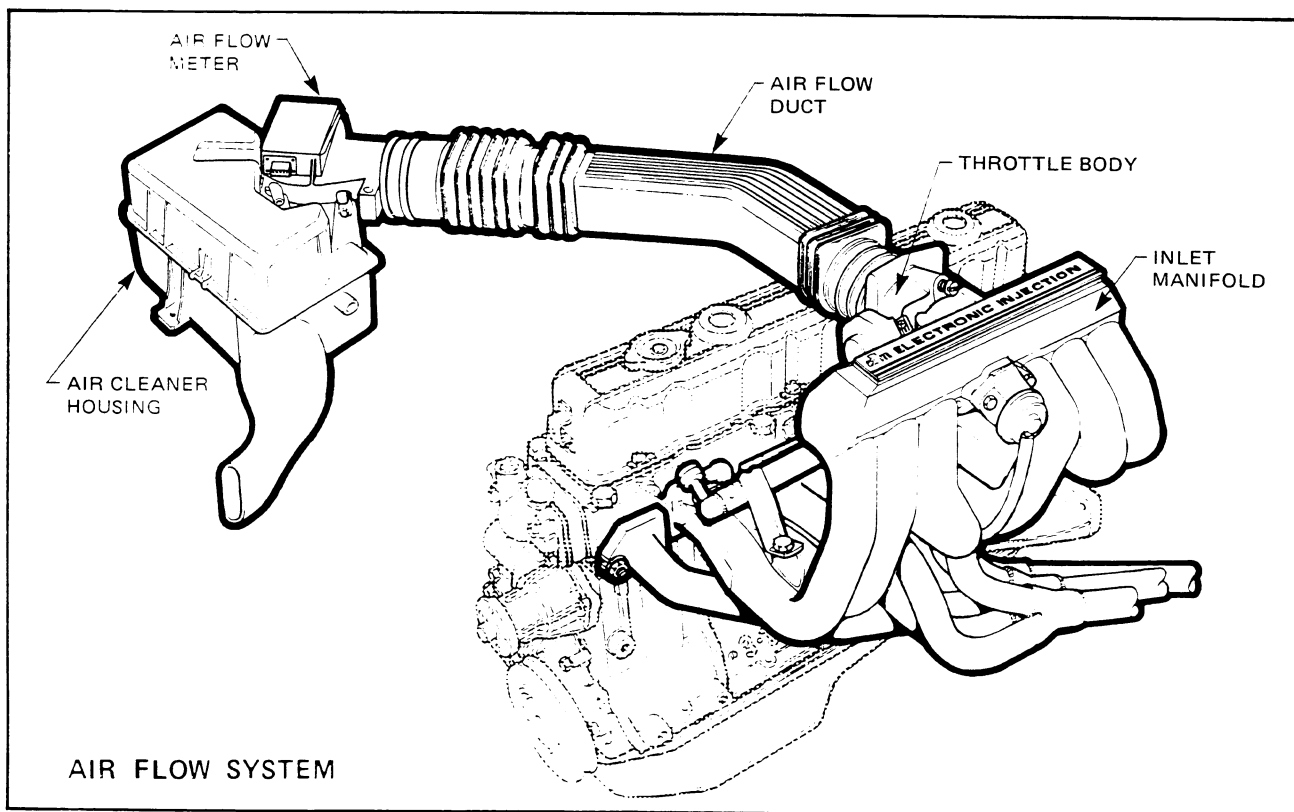

Figure 6C-1

1.1 MAIN COMPONENT SYSTEMS

The Bosch LE-2 Jetronic Fuel Injection system can be divided into three main component systems, they are:

AIR FLOW SYSTEM

COMPRISING:

Air Cleaner - Filters incoming air flow for the engine. Refer Fig. 6C-1.

Air Flow Meter - Measures the air inlet flow and sends an electrical signal to the control unit where the required air/fuel ratio is computed. Refer Fig. 6C-1.

Air Flow Duct - Transfers air flow from air cleaner to throttle body. Refer Fig. 6C-1.

Throttle Body - Located between the air flow duct and the inlet manifold, the throttle body incorporates the throttle valve with provision for Exhaust Gas Recirculation, spark advance, canister purge signals and Positive Crankcase Ventilation connection. The throttle valve is connected to the accelerator linkage and controls the flow of air into the inlet manifold. Refer Fig. 6C-1.

Inlet Manifold - Distributes air to the inlet ports of the cylinder head. Refer Fig. 6C-1.

Auxiliary Air Valve - Allows an additional amount of air to bypass the throttle valve, to maintain idle stability with a cold engine. Refer Fig. 6C-2.

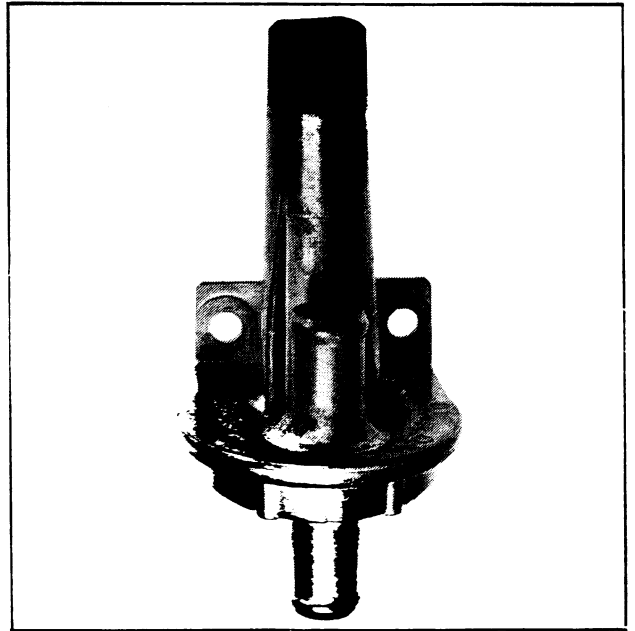

Figure 6C-2

FUEL SYSTEM

COMPRISING:

Fuel Tank - Contains a very fine strainer attached to the fuel pick up on the fuel gauge sender unit. Also included in the fuel tank, is a fuel swirl pot, to minimise aeration at fuel pick up point. Refer Section 8A of this Supplement for further details.

Fuel Pump - An electric, rotary roller pump. Refer Fig. 6C-3.

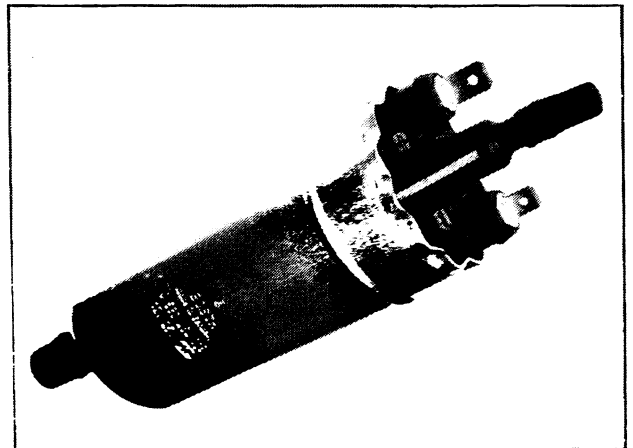

Figure 6C-3

Fuel Damper - Designed to remove fuel pulsations from the fuel system. Two dampers are fitted in the fuel system. Refer Fig. 6C-4.

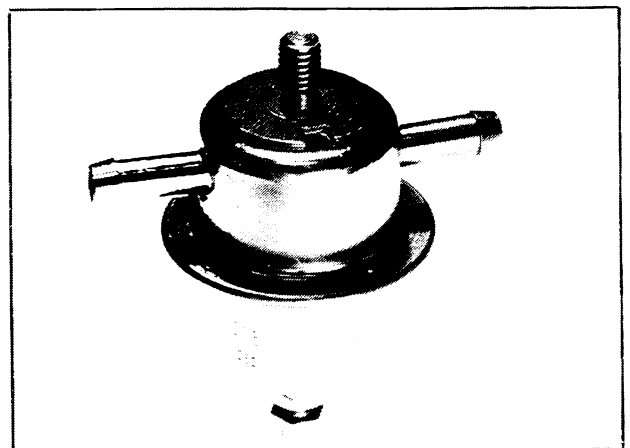

Figure 6C-4

6C-4 ENGINE FUEL

Fuel Filter - The filter contains a fine paper element. Refer Fig. 6C-5.

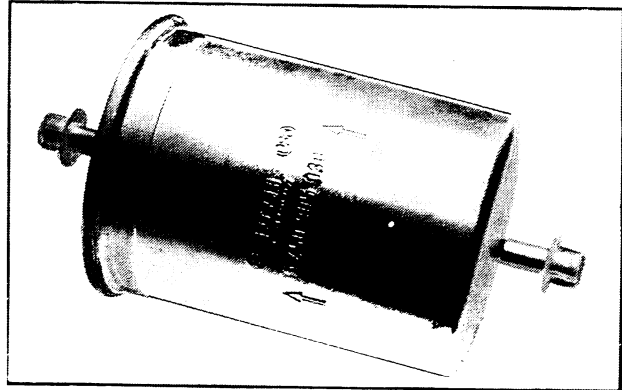

Figure 6C-5

Fuel Rail - Distributes pressurized fuel to the injectors. Refer Fig. 6C-6. It incorporates a schrader valve (with a special fuel resistant valve core) for bleeding down fuel pressure and carrying out diagnostic procedures.

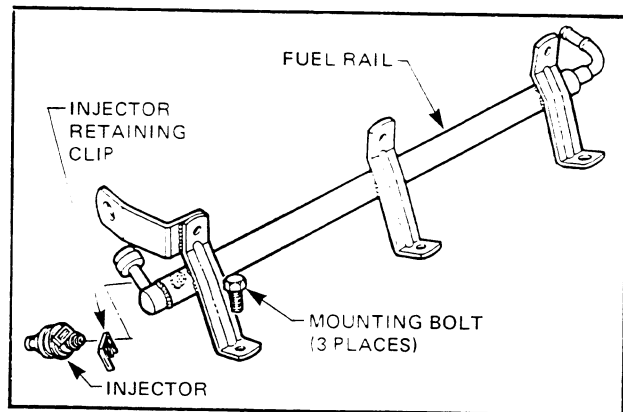

Figure 6C-6

Injectors - Electrically controlled from the control unit. The amount of fuel sprayed into the inlet ports is controlled by the length of time the control unit signals the injectors to remain open. Refer Fig. 6C-7.

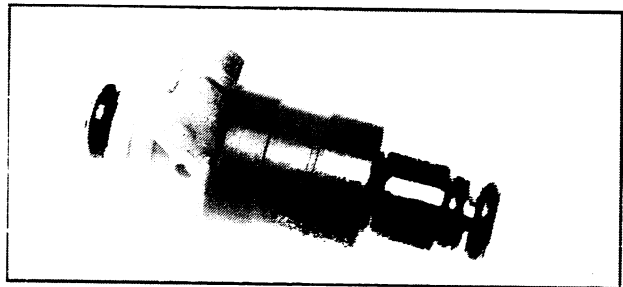

Figure 6C-7

Pressure Regulator - Maintains the required fuel pressure under all load conditions. Refer Fig. 6C-8.

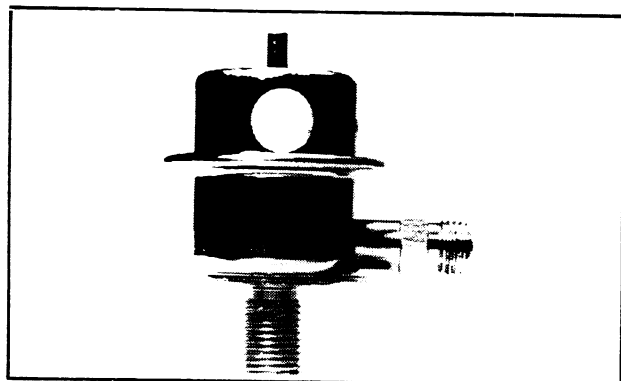

Figure 6C-8

ELECTRICAL SYSTEM

COMPRISING:

Control Unit - Processes signals from the engine sensors to calculate the amount of time the injectors remain open. Refer Fig. 6C-9.

Control Unit Inputs - Include: ignition coil, air flow meter, throttle position switch, engine coolant temperature sensor, inlet air temperature sensor and ignition switch position.

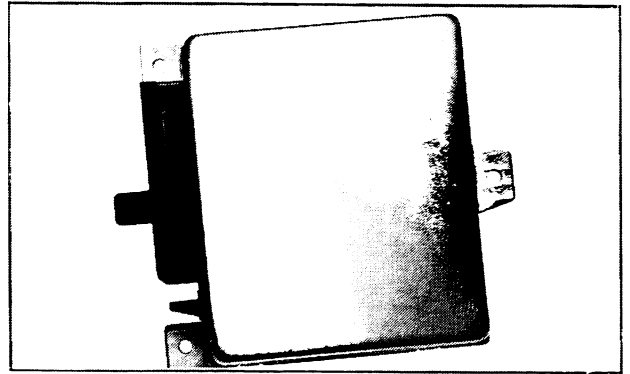

Figure 6C-9

Ignition Coil - The control unit receives ignition pulses from the ignition coil. From this information the control unit calculates engine speed. Refer Fig. 6C-10.

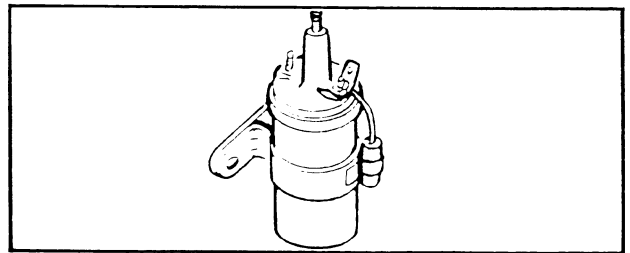
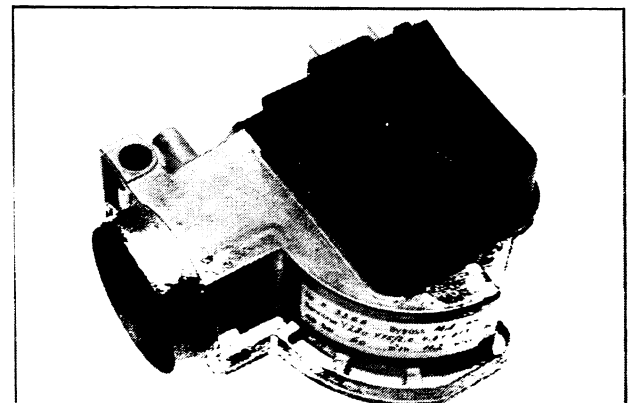

Figure 6C-10

Air Flow Meter - The control unit receives information about the engine's load condition from the air flow signal sent from the air flow meter. Refer Fig. 6C-11.



Throttle Position Switch - The control unit receives information from the throttle position switch when the engine is idling or under high load. Refer Fig. 6C-12.

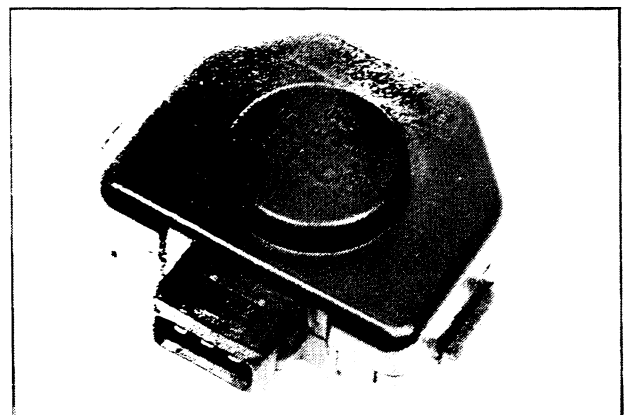

Figure 6C-12

6C-6 ENGINE FUEL

Coolant Temperature Sensor - The control unit receives information about the engine coolant temperature from this sensor. The sensor is of a Negative Temperature Coefficient design. The resistance of the sensor decreases as the engine temperature increases, thereby allowing the control unit to shorten the injection pulse width signal. Refer Fig. 6C-13.

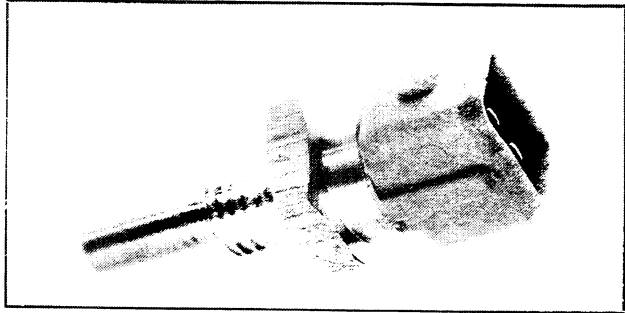

Figure 6C-13

Air Temperature Sensor - The air temperature sensor is located in the inlet passage of the air flow meter housing. It is also of the Negative Temperature Coefficient design, and it applies a correction factor to the air flow meter output signal to compensate for changes in inlet air temperature. Refer Fig. 6C-14.

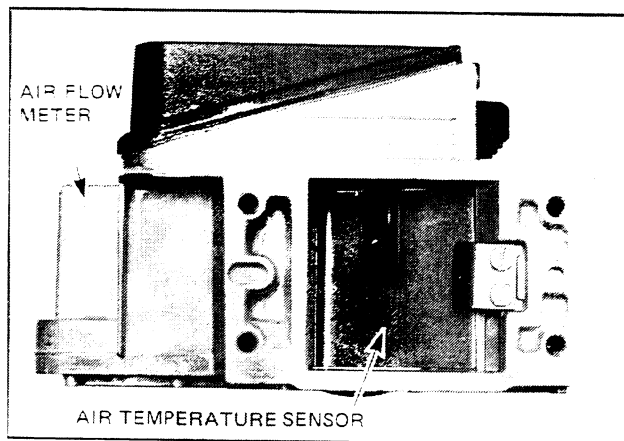

Figure 6C-14

Ignition Switch - The control unit receives a signal from the ignition switch when the vehicle is starting, and this allows a richer mixture for starting. Refer Fig. 6C-15.

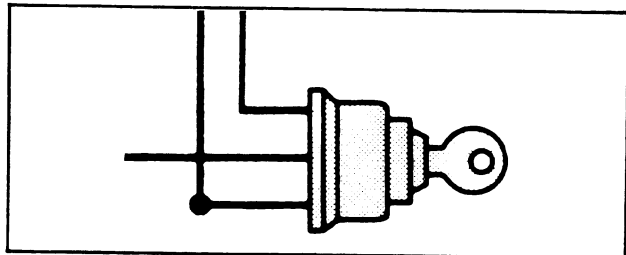

Figure 6C-15

The location of the various components are shown in Figs. 6C-16, 6C-17.

ENGINE FUEL 6C-7

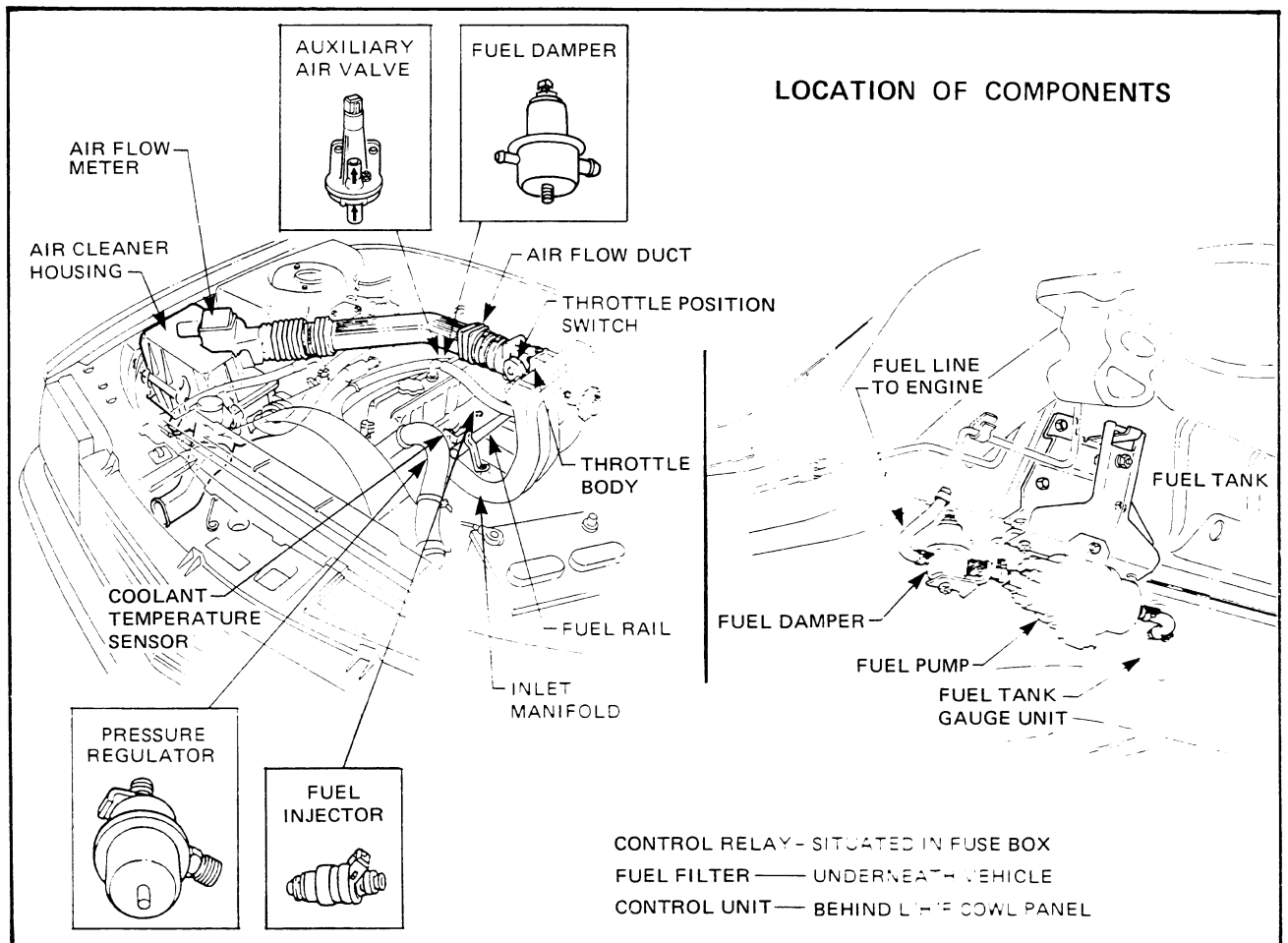

Figure 6C-16

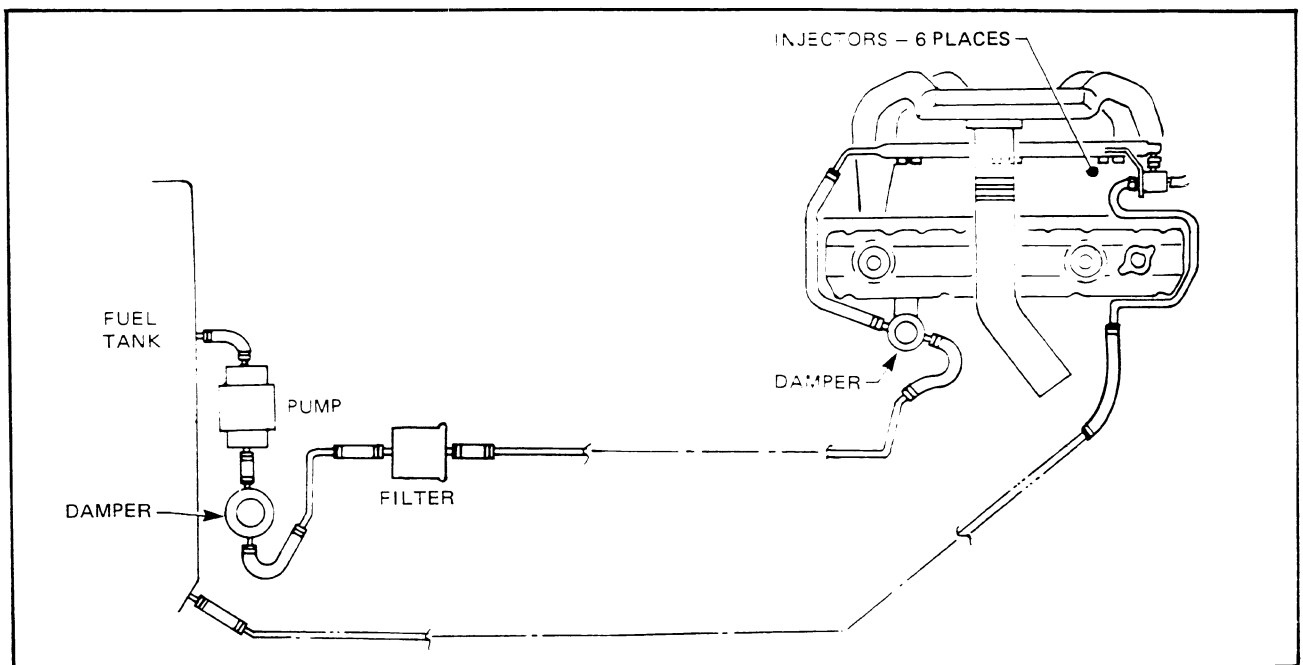

Figure 6C-17

6C-8 ENGINE FUEL

1.2 FUNCTION OF MAIN COMPONENT SYSTEMS

AIR FLOW SYSTEM

Inlet air flows through the air cleaner housing and is measured by the air flow meter. Air continues along the air flow duct into the throttle body. Air flow to the engine is controlled by the throttle butterfly opening inside the throttle body.

During engine warm up, additional air flow is bypassed behind the throttle butterfly to increase engine speed, by the action of the auxiliary air valve. Refer Fig. 6C-18.

FUEL SYSTEM

Fuel is drawn from the fuel tank by the electric fuel pump and it is fed under pressure through the fuel damper. Pulsations caused by the fuel pump are deadened by the fuel damper. From the damper the fuel flows through a fuel filter, and through a second fuel damper to reduce the fuel pulsations generated by the opening and closing of the injectors. The fuel continues on into the fuel rail and then is injected into the inlet ports through the injectors.

Fuel pressure in the system is governed by the pressure regulator, in such a manner that the pressure difference between fuel pressure and inlet manifold vacuum is maintained at 303 kPa (3 bar). Excess fuel is returned to the fuel tank by the pressure regulator via the fuel return line. Refer Fig. 6C-19.

ELECTRICAL SYSTEM

The control unit receives information from the various sensors and, based on this information, it sends out an electrical pulse to the injectors, the duration of which controls the amount of time the injector nozzle remains open.

Information gathered includes, inlet air flow from the air flow meter, engine coolant and inlet air temperatures from their respective sensors and engine speed from the ignition coil pulses. Refer Fig. 6C-20.

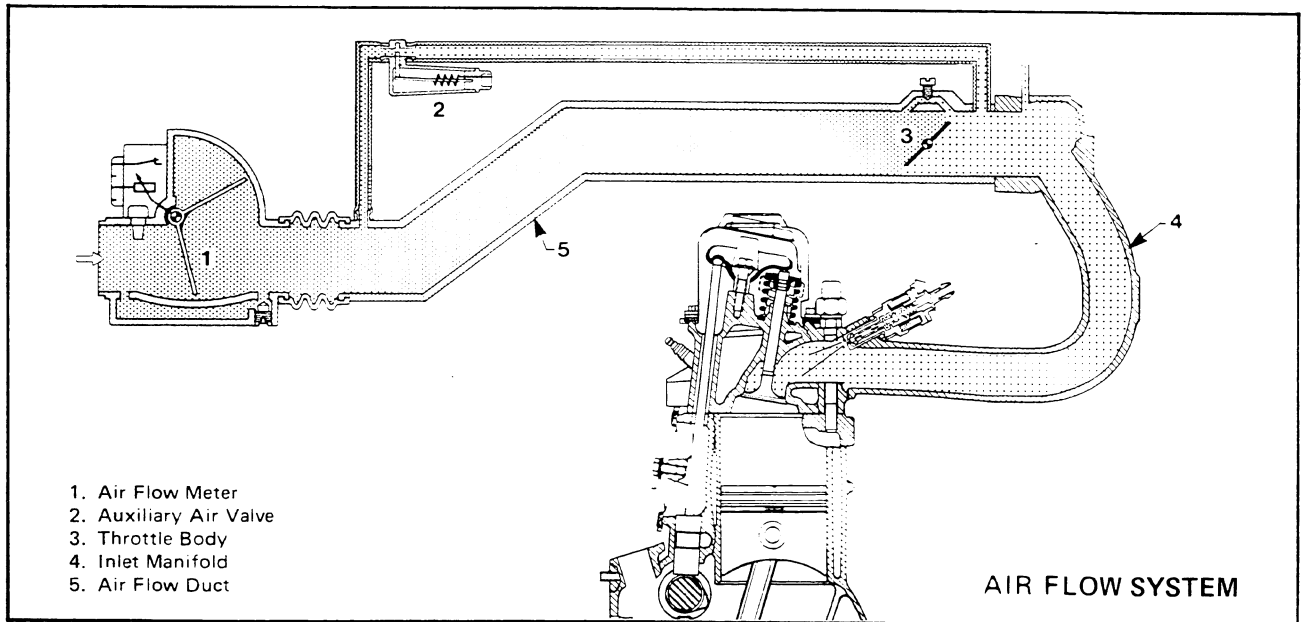

Figure 6C-18

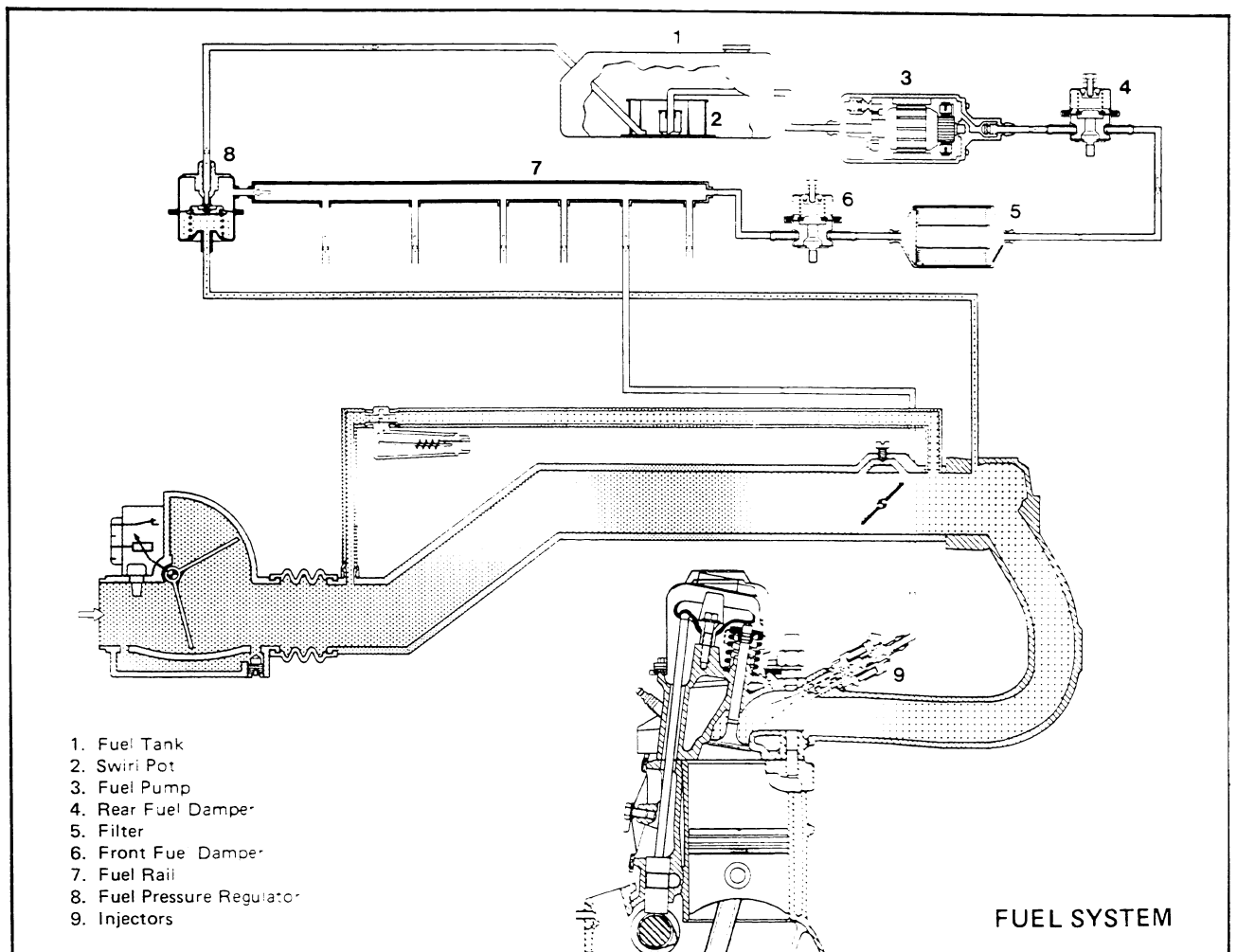

Figure 6C-19

6C-10 ENGINE FUEL

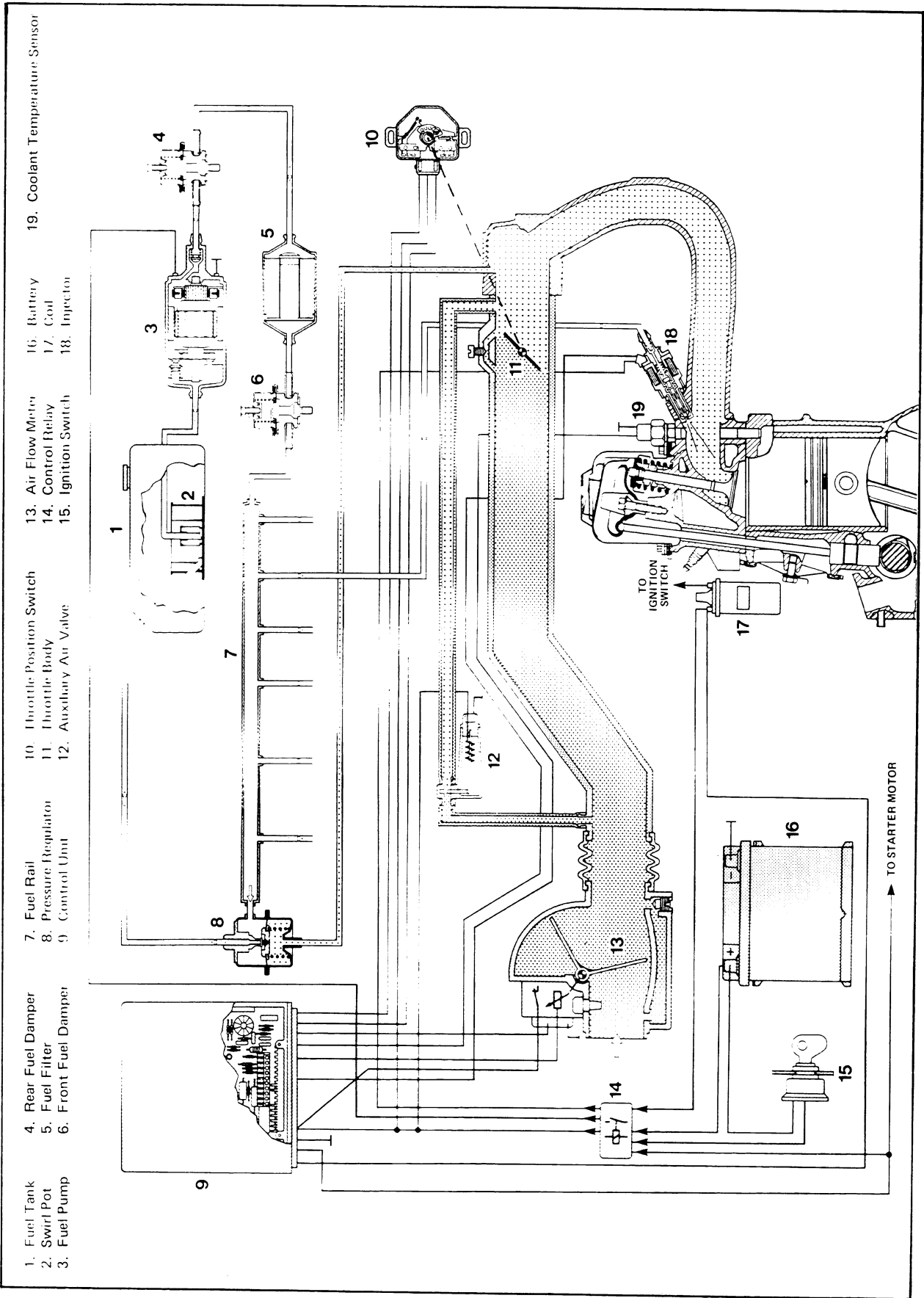

Figure 6C-20

Control Unit Signals

The main function of the control unit is to generate injection pulses. Upon receiving electrical signals from the engine sensors, the control unit generates a pulse whose duration (injector opening time) is controlled to provide an optimum quantity of fuel according to the engine requirements. Because the opening and closing reaction time of the injectors is dependant on battery voltage, the control unit also varies the injection pulse width to compensate for fluctuations in the system voltage.

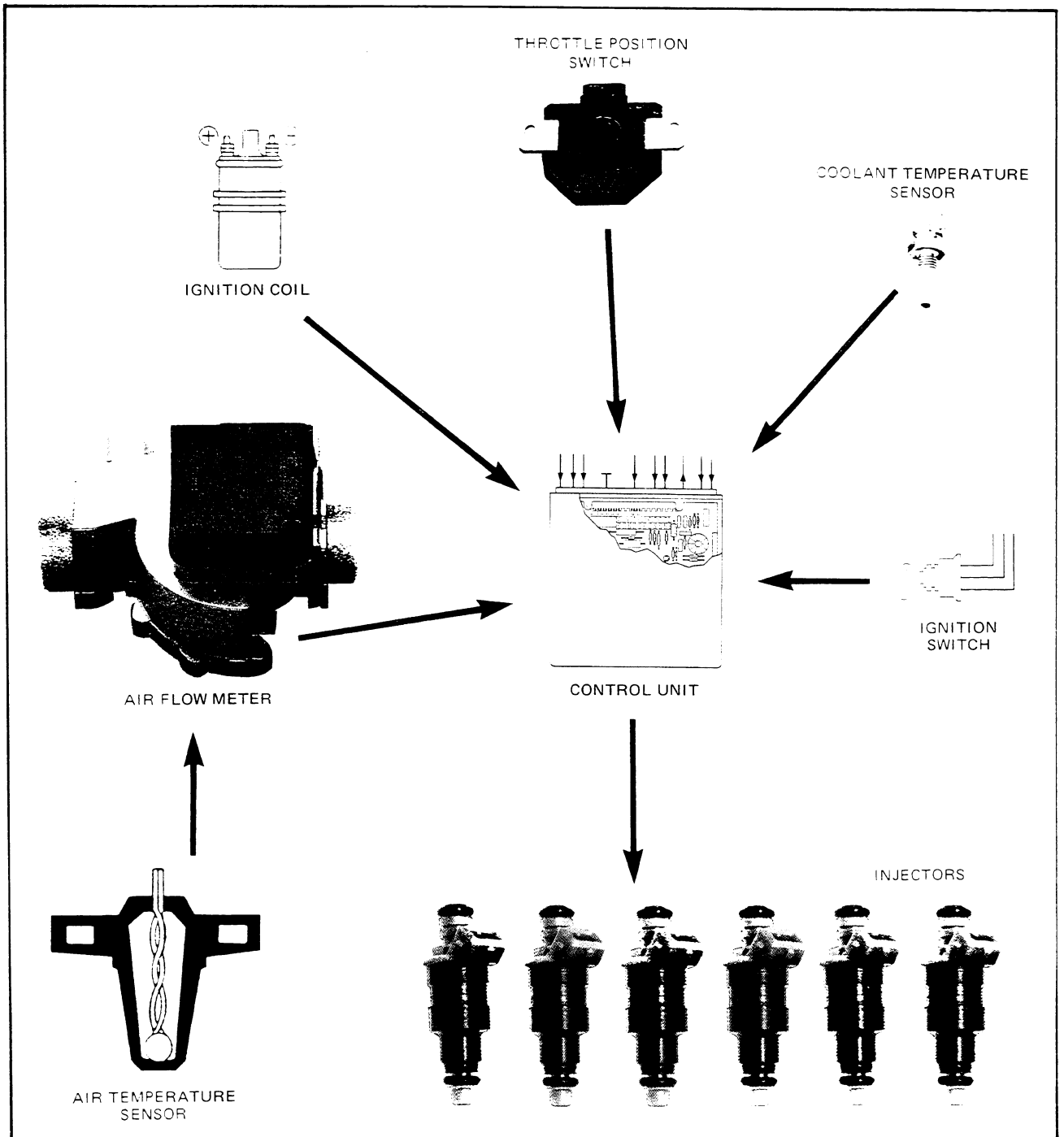

Figure 6C-21

6C-12 ENGINE FUEL

2. PRINCIPLES OF OPERATION

2.1 FUEL INJECTION TIMING

With many early fuel injection systems, fuel was injected into the inlet port just prior to the beginning of the intake stroke.

This is not the case with the LE-2 Fuel Injection System. The signal for injection begins with the control unit receiving ignition pulse signals from the ignition coil.

With a six cylinder engine, there are six ignition pulses for every two engine revolutions (three pulses every revolution). Upon receiving the third ignition pulse from the coil, the control unit sends the signal for injection to commence. All the fuel injectors are electrically connected in parallel to the control unit so they all inject simultaneously.

One injection of fuel provides only half the required quantity necessary for the operation of the 4-stroke cycle of the engine, therefore injection is made twice during one 4-stroke cycle, i.e. once every engine revolution. Refer Fig. 6C-22.

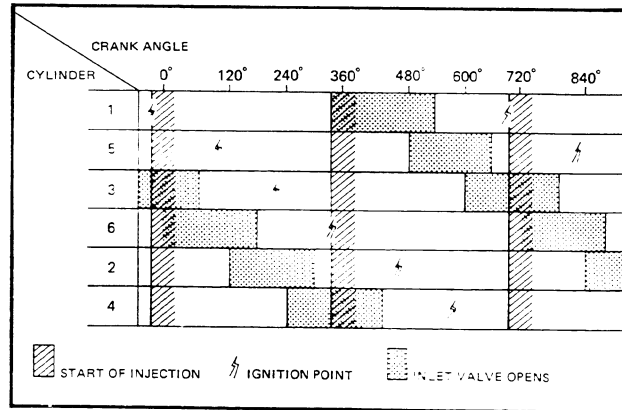

Figure 6C-22

2.2 FUEL INJECTION QUANTITY

Vehicle engine speed and load are the two requirements needed to calculate the basic fuel requirements for any engine operating condition.

With LE-2, the speed of the engine is signalled from the ignition coil and engine load is monitored by the air flow meter. The signals from these two sensors provide the control unit with data to select the basic fuel injection quantity.

2.3 ENRICHMENTS

The basic fuel injection quantity is not enough for all engine operating conditions. Extra fuel quantity is required for cold starting, engine warm up and acceleration. Refer Fig. 6C-23.

Various sensors produce electrical signals which are directed to the control unit so as to provide the extra fuel quantity.

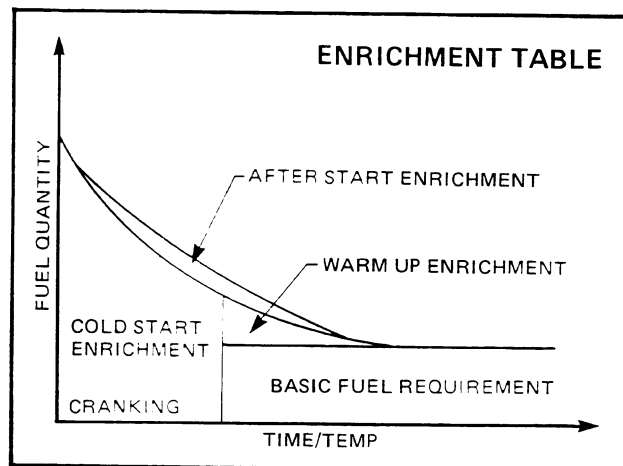

Figure 6C-23

ENRICHMENT SENSORS

Air and Coolant Temperature Sensors

Enrichment signals are generated from both sensors. The lower the air or coolant temperature, the longer the injection signal, the longer the injectors remain open and the larger the quantity of fuel injected, until the engine reaches operating temperature when enrichment compensation is no longer required.

Throttle Position Switch

The switch contains two contact point sets, one monitoring the closed throttle position and the other for high load.

An enrichment signal is sent to the control unit when either of the contact point sets are closed. At closed throttle, the idle contacts are closed and high load points are open. At part throttle, both contact point sets are open. At high load, the closed throttle contacts are open and high load contacts closed.

Ignition Switch

The start enrichment signal is generated in the 'START' position of the ignition switch.

Various fuel enrichment corrections are computed as a result of these signals in order to provide optimum fuel injection under all engine operating conditions.

Cold Start

When the ignition switch is turned to the 'START' position and the engine is in the 'cranking' mode, the control unit delivers 3 injection pulses per rev and extra fuel is injected into the inlet ports.

Cold start enrichment can last for a period up to 10 seconds depending on the temperature of the engine. Refer Fig. 6C-24.

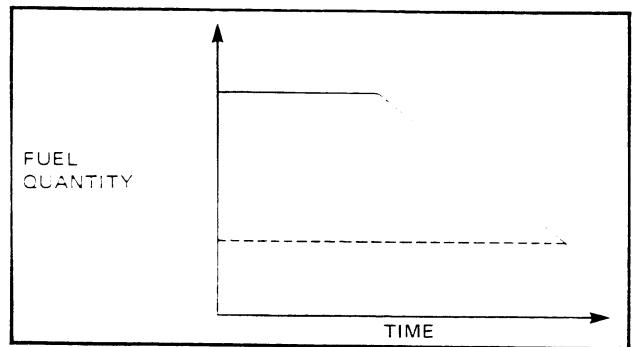

Figure 6C-24

After Start

When the ignition switch is released to the 'ON' position from 'START', the cold start enrichment drops off. The 'after start' enrichment is provided to compensate for the sudden decrease in fuel quantity from 'START' to 'ON'. The control unit multiplies the basic fuel injection quantity pulse by a factor of 1.7 at 0°C, this factor decreases until the engine speed becomes greater than 600 rpm. Refer Fig. 6C-25.

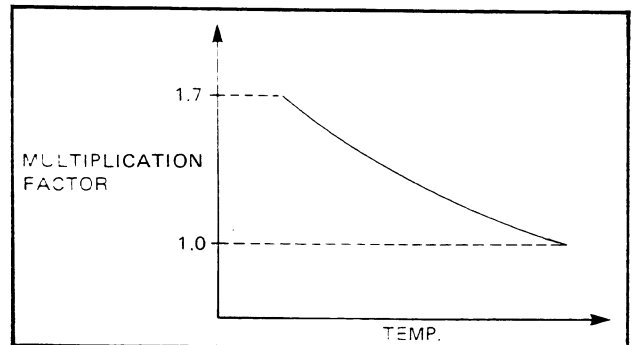

Figure 6C-25

Warm Up

The warm up enrichment provides smooth engine operation once the engine is started. The control unit again multiplies the basic fuel injection quantity by a factor which is controlled by the engine's coolant temperature. Refer Fig. 6C-26.

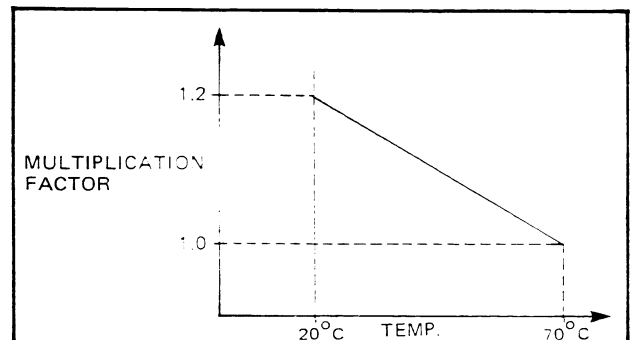

Figure 6C-26

6C-14 ENGINE FUEL

ACCELERATION ENRICHMENT

The control unit receives a signal from the air flow meter about an increase in airflow and if the coolant temperature is less than 70°C, acceleration enrichment takes place. The control unit multiplies the basic fuel injection quantity by a factor to increase the fuel quantity delivered. The enrichment signal lasts approximately 2 seconds. Refer Fig. 6C-27.

FULL THROTTLE (HIGH LOAD) ENRICHMENT

The high load contacts within the throttle position switch close when the throttle is opened greater than 40°. With closed contacts, the control unit receives an electrical signal and the basic fuel injection quantity is increased by 8 percent to give the air fuel ratio required for maximum power.

2.4 FUEL SHUT OFF - COASTING

When the accelerator pedal is lifted so the vehicle is coasting, the closed throttle contact points within the throttle position switch close. With the points closed, the control unit receives an electrical signal and fuel injection is stopped until the engine speed drops to approximately 1800 rpm. With engine speed below 1800 rpm, fuel injection commences again to prevent the engine from cutting out. Refer Fig. 6C-28.

2.5 VOLTAGE CORRECTION FUNCTION

Under conditions of low system voltage, such as would occur with a battery in a low state of charge, the injectors are slightly slower to open. Under these conditions, the pulse width is automatically extended to ensure the full quantity of fuel is injected.

2.6 COMPONENT OPERATION

AIR FLOW SYSTEM

Air Flow meter

The function of the air flow meter is to generate an electrical signal to the control unit proportional to the amount of air flow into the engine. This signal is the base engine load signal to determine the correct amount of fuel to be injected.

In the inlet passage of the air flow meter there is a moveable flap and as the air flows through the passage it exerts a force on this flap. Depending on the air flow and the opposing force of the flap return spring, the flap is held open in a certain angular position which is converted to an electrical signal by a potentiometer (variable resistor).

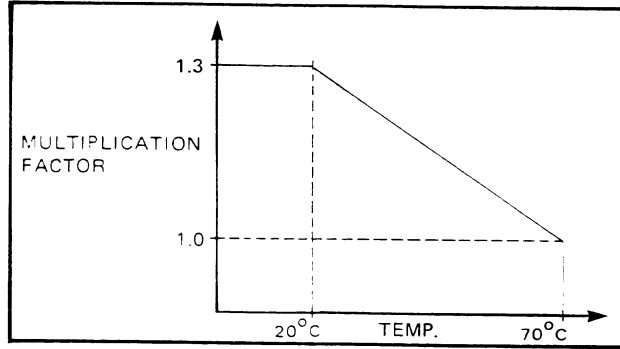

Figure 6C-27

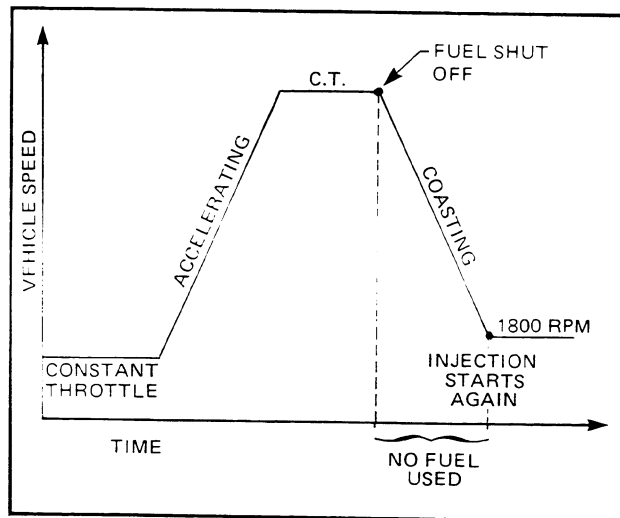

Figure 6C-28

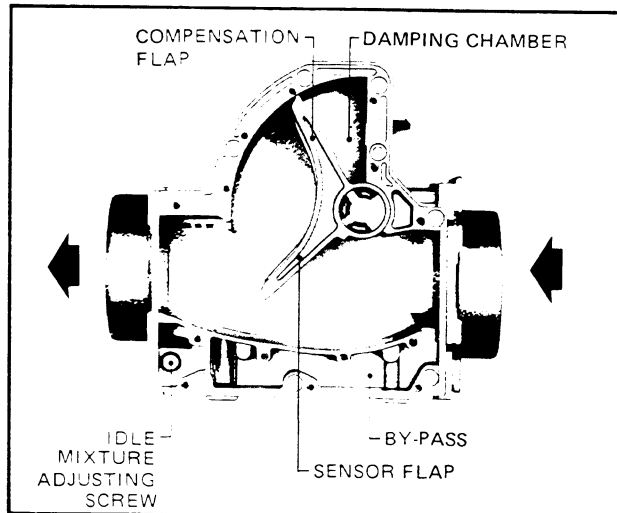

Figure 6C-29

When the air flow flap is moved with a change in air flow, a terminal connected to the air flow flap shaft slides on the variable resistor, causing the output voltage to the control unit to change.

Connected to the air flow flap is a compensation flap working in a damping chamber. The need for the extra flap and chamber is to provide the air flow flap with a damper so that it cannot be disturbed by pulsations from inlet manifold vacuum during engine operation.

In order to set the air fuel ratio at idle, an adjustable air bypass passage is provided. By varying the quantity of air which is allowed to bypass the flap, the air flow meter signal can be changed sufficiently to alter the air fuel ratio at idle.

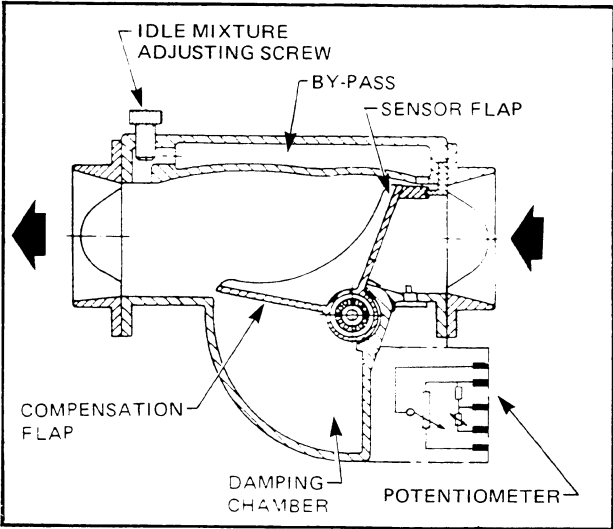

Figure 6C-30

Throttle Body

The throttle body is located on the inlet manifold and it contains a throttle butterfly valve. This valve controls the inlet air flow corresponding to movement from the accelerator pedal. The butterfly valve shaft is connected to the throttle position switch.

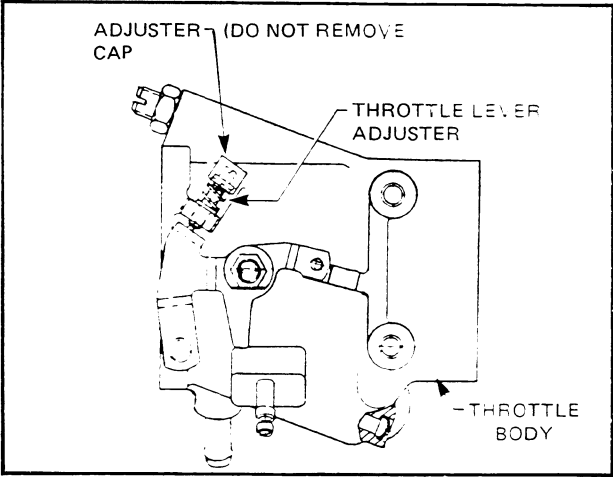

Figure 6C-31

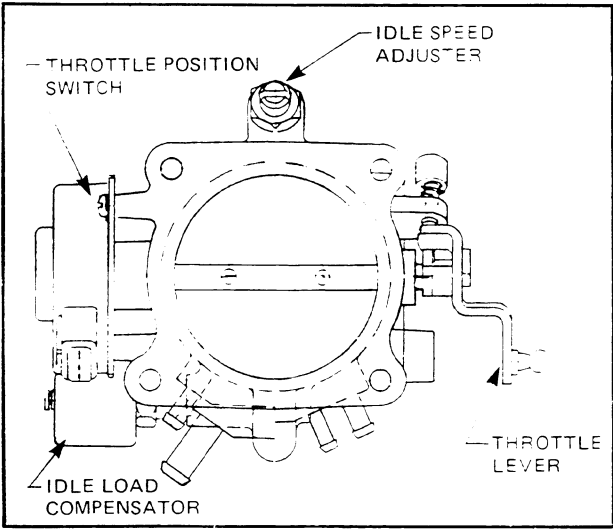

Figure 6C-32

6C-16 ENGINE FUEL

Idle speed adjustment is carried out by loosening off the idle speed adjuster lock nut and screwing the adjuster in or out to set the desired idle speed. This allows a variance in the amount of air to bypass the throttle butterfly valve. This variance in air flow is measured by the air flow meter, and so the control unit changes the injector pulse width accordingly. Refer Fig. 6C-33.

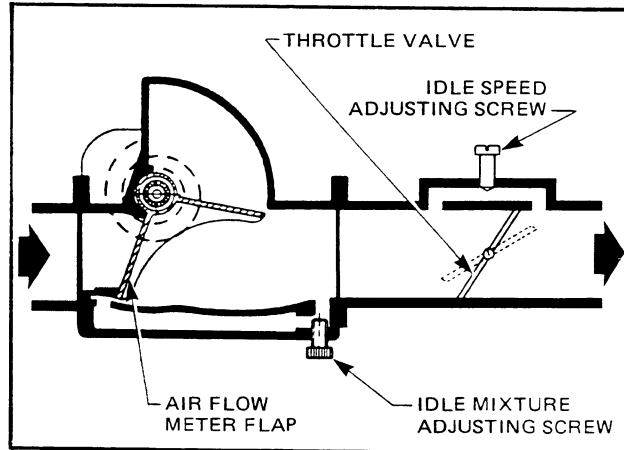

Figure 6C-33

When the vehicle is fitted with air conditioning, an idle load compensator solenoid is installed in the throttle body. When the air conditioning compressor is operating, the solenoid is energized. This allows an extra quantity of air to bypass the throttle butterfly valve. The control unit increases the pulse width signal to the injectors because of the greater air flow past the air flow meter and the engine idle speed is increased. Refer Fig. 6C-34.

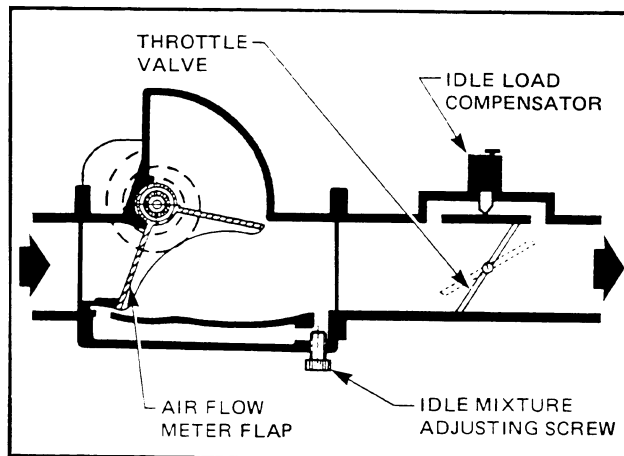

Figure 6C-34

Auxiliary Air Valve

When the engine is cold, it must produce higher torque during idle to overcome increased frictional resistances. Therefore, in addition to a richer air/fuel ratio during cold starting and warm up period, additional mixture is required to increase the engine's idle speed. The additional mixture is obtained by the action of the auxiliary air valve. The auxiliary air valve operation is controlled by an electric heater coil which, when the engine is cold, permits air to bypass the throttle valve and enter the inlet manifold. The additional air entering the induction system causes the flap within the air flow meter to deflect and the potentiometer signals the control unit that more fuel is required thereby maintaining the air fuel ratio constant. Refer Fig. 6C-35.

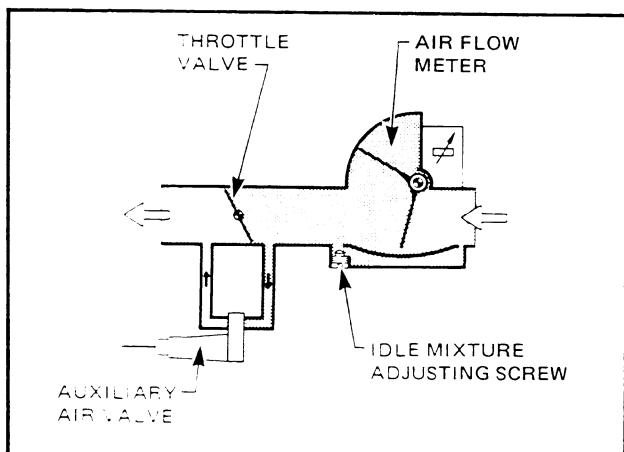

Figure 6C-35

The auxiliary air valve contains a slotted disc that rotates to open, close or partially close an air passage in the valve. Current flows through the heater coil which controls the operation of a bimetal spring which rotates the slotted disc.

The current flow to the valve begins when the ignition is switched to 'START' and continues whenever the engine is running.

With a cold engine, the bimetal strip keeps the disc positioned to open the air passage, permitting air from the air flow duct to enter the throttle body, bypassing the throttle valve. As the heater coil warms up, the bimetal strip deflects, gradually closing the air passage in the valve until at a predetermined temperature, the disc has completely closed the passage and idle compensation via the auxiliary air valve ceases. Refer Fig. 6C-36.

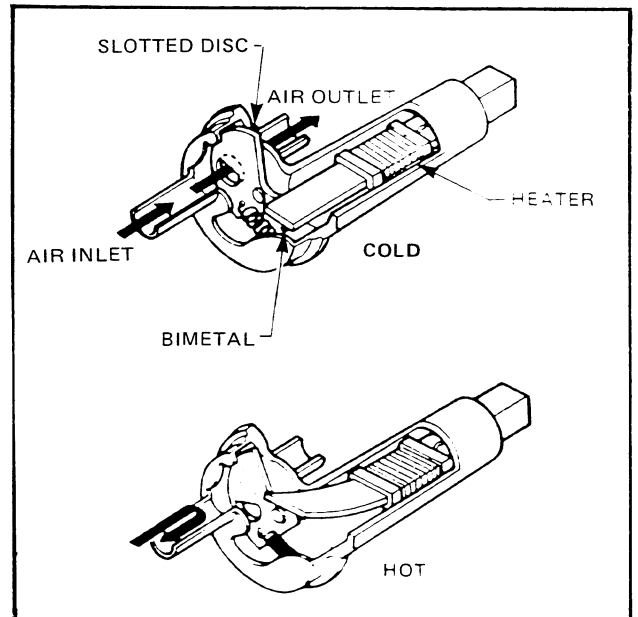

Figure 6C-36

FUEL SYSTEM

Fuel Pump

The electric fuel pump is a roller-cell type. Current to operate the fuel pump is fed through a control relay, located in the fuse box. Refer Fig. 6C-37.

The pump is driven by a permanent magnet electric motor which is permanently immersed in fuel.

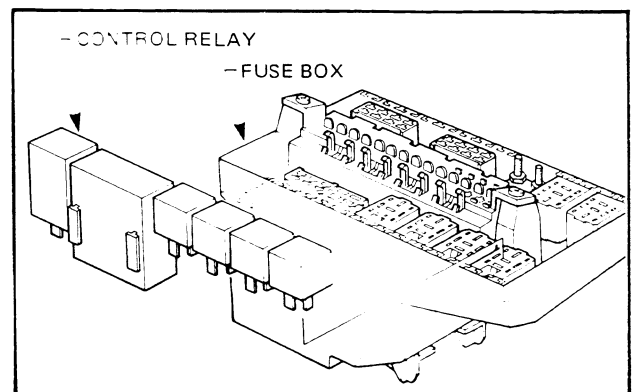

Figure 6C-37

The rotor disc, which is eccentrically mounted in the pump housing, is fitted with metal rollers in notches around its circumference which are pressed against the thrust ring of the pump housing by centrifugal force and act as seals. The fuel is carried in the cavities which form between the rollers. The fuel flows directly around the electric motor. There is no danger of explosion, however, because there is never an ignitable mixture in the pump housing. The pump delivers more fuel than the maximum requirement of the engine so that the pressure in the fuel system can be maintained under all operating conditions.

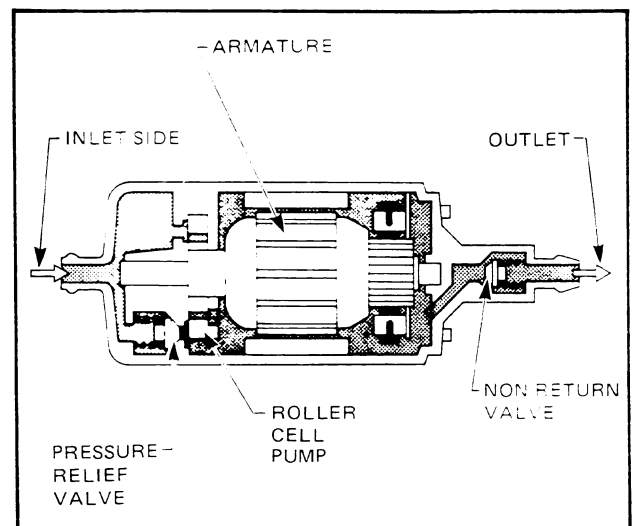

Figure 6C-38

6C-18 ENGINE FUEL

The pump incorporates a check valve to maintain system pressure after the pump is shut off. Also incorporated, is an internal relief valve which provides protection from excessive pressure.

The fuel pump capacity is 130 l/hr.

NOTE: This type of pump can be noisy when pumping aerated fuel, as can occur with a low fuel level in the tank under very hot conditions. It is not harmful to the pump.

The fuel pump is a sealed unit and is not repairable.

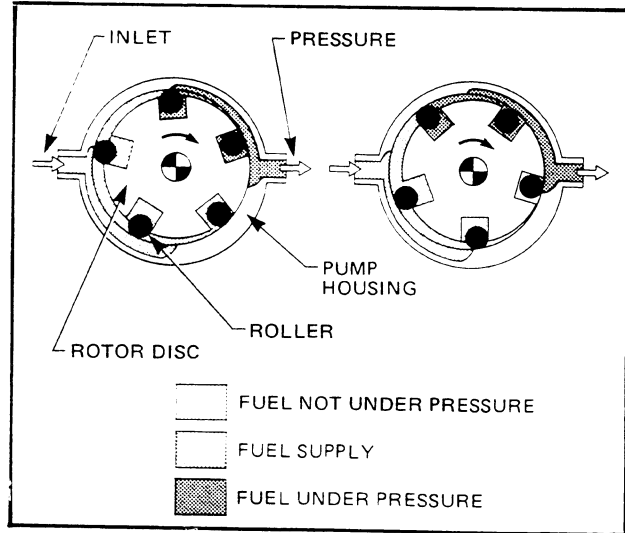

Figure 6C-39

Fuel Damper

The purpose of the fuel damper is to suppress the fuel flow pulsations from the fuel pump and the injectors. Two dampers are used in the system. The first is situated at the pressure outlet of the fuel pump and the other is placed prior to the fuel entry into the fuel rail.

Changes in the fuel pressure discharged from the fuel pump and the opening and closing of the injectors, are monitored by the diaphragm and spring, which varies the volume of the fuel chamber thereby suppressing fuel pressure pulsations. Refer Fig. 6C-40.

The fuel dampers are sealed units and are non adjustable in service and are not repairable.

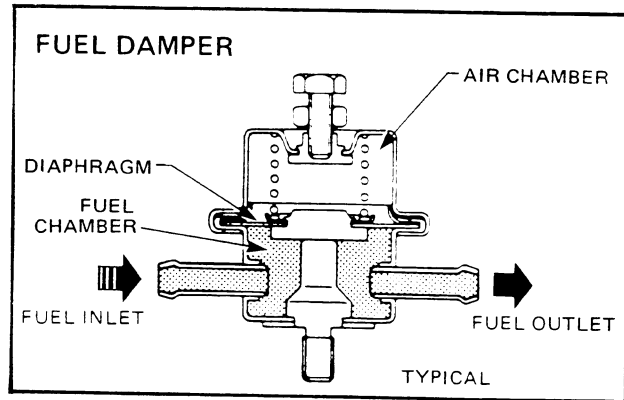

Figure 6C-40

Fuel Injectors

Each fuel injector incorporates a solenoid, controlled by electric pulses from the control unit together with an armature attached to a pintle valve which, when activated, opens inwardly. A spring holds the pintle valve closed as long as the solenoid is not activated. When the solenoid is energized, the pintle valve opens and the fuel is metered and atomised as it enters the inlet port. Since the fuel pressure drop across the injector is always constant, the amount of fuel delivered is directly proportional to the pulse width and therefore, the time the injector is open.

Typical injection time for most engine operating conditions range from 2.5 to 10 milliseconds. Refer Fig. 6C-41 for internal view of a typical injector.

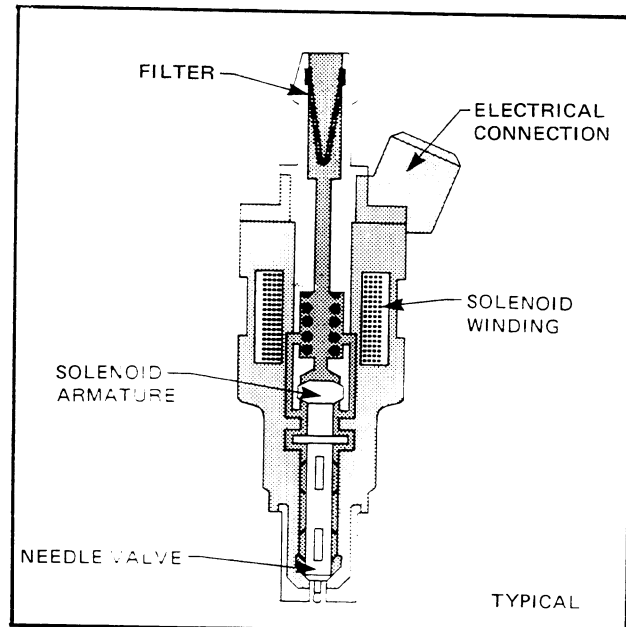

Figure 6C-41

The injector has around each end, a sealing 'O' ring, which should be replaced every time the injector is removed. Refer Fig. 6C-42.

The cap on the injector tip is to protect the injector pintel from damage during handling and fitting and also, to provide heat insulation to prevent vapour formation. It SHOULD NOT BE REMOVED. Refer Fig. 6C-42.

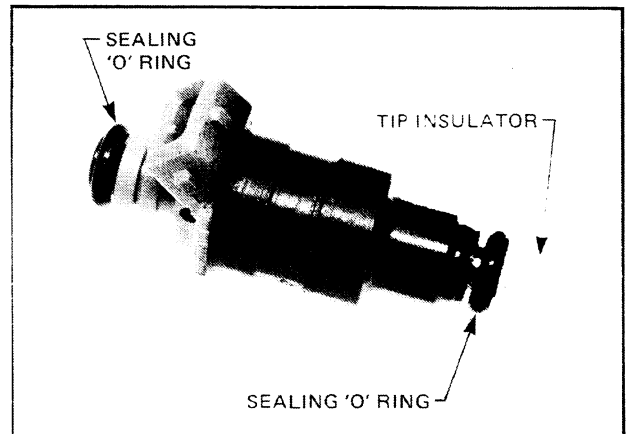

Figure 6C-42

Fuel Pressure Regulator

The fuel pressure regulator (Fig. 6C-43) is a diaphragm operated relief valve used to maintain fuel system pressure to 303 kPa above the inlet manifold depression. The diaphragm senses fuel pressure on one side while the other side is exposed to inlet manifold vacuum. A spring, mounted in the engine vacuum side of the diaphragm, establishes a nominal pre-load of pressure. With the fuel pump constantly supplying fuel to the regulator, a situation of too much fuel at the regulator is created. When pressure greater than 303 kPa above the inlet manifold depression is sensed, the diaphragm moves to allow excess fuel to be routed back to the fuel tank.

The continuous flow of excess fuel to the petrol tank helps ensure that the injected fuel is cool and vapour free. The regulator is a sealed unit and cannot be repaired.

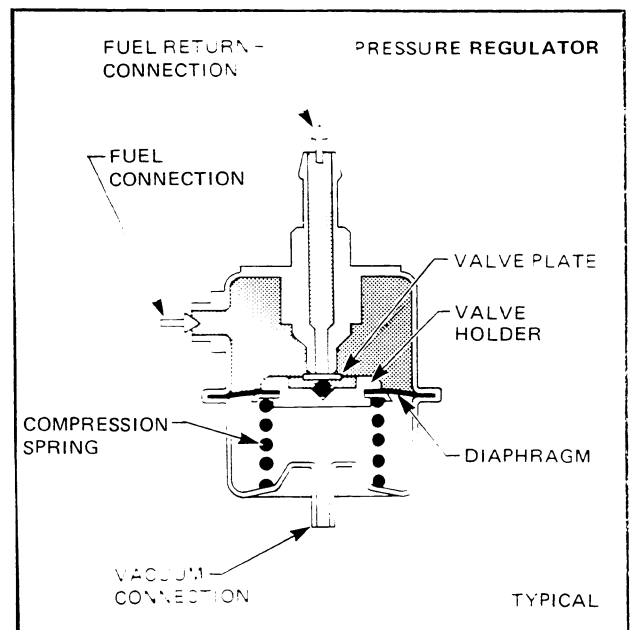

Figure 6C-43

Fuel Filter

Due to the extremely close tolerances of various components in the fuel system, it is necessary to fit a special, fine filter for the fuel. The filter retains impurities which maybe present in the fuel and which could affect the function of the fuel injection system.

The fuel filter contains a paper element. Refer Fig. 6C-44.

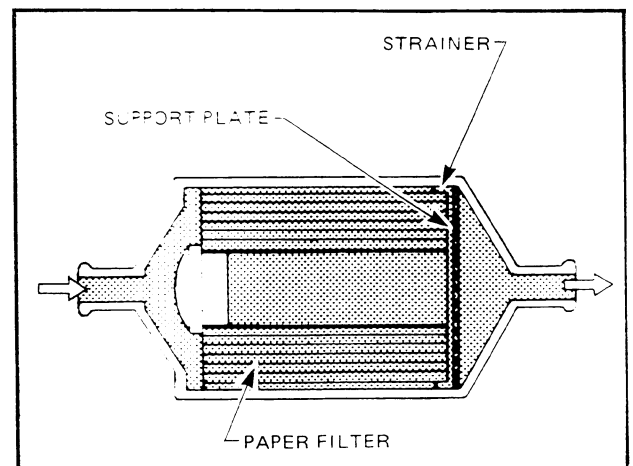

Figure 6C-44

6C-20 ENGINE FUEL

When replacing the filter it is of the **utmost importance** that the **arrow on the housing indicating the flow is complied with**. Refer Fig. 6C-45.

The filter must be replaced every 40,000 kms or 2 years, whichever comes first.

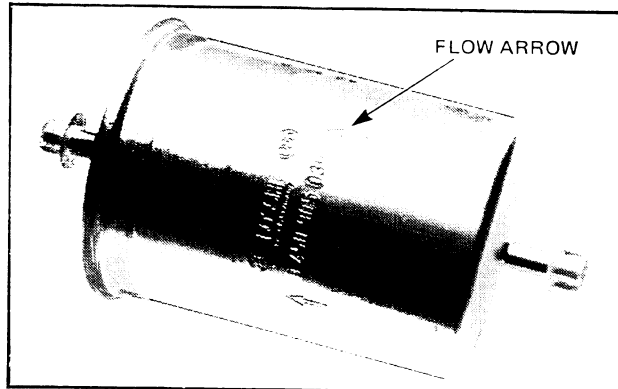

Figure 6C-45

Fuel Rail

The fuel rail guarantees the same fuel pressure at each injector.

The fuel rail has a storage function. Its volume compared with the amount of fuel injected during each working cycle of the engine is large enough to prevent variations in pressure. The injectors, connected to the fuel rail, are therefore subjected to the same fuel pressure. The fuel rail also facilitates fitting of the injectors, and also incorporates a schader valve for bleeding down fuel pressure and carrying out diagnostic procedures. Refer Fig. 6C-46.

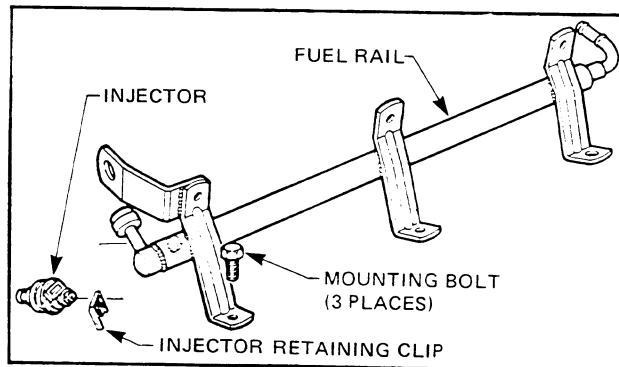

Figure 6C-46

ELECTRICAL SYSTEM

Control Unit

The electronic control unit is a pre-programmed analog computer consisting of custom electronic circuits housed in a metal case. The control unit is mounted behind the passenger side front cowl panel trim. Refer Fig. 6C-47.

The control unit receives information on the quantity of air drawn into the engine, coolant temperature, position of the throttle valve, the starting process, as well as engine speed. It processes this information and transmits electric pulses to the injectors. It is connected with the electrical components in the system by means of a multiple pin plug and wiring harness.

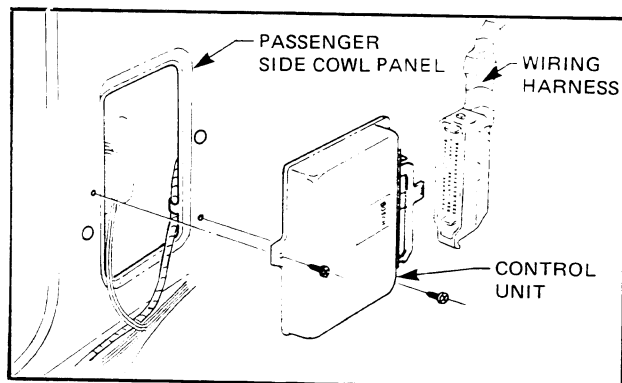

Figure 6C-47

Coolant Temperature Sensor

The coolant temperature sensor is located towards the front of the cylinder head, on the manifold side. Refer Fig. 6C-48.

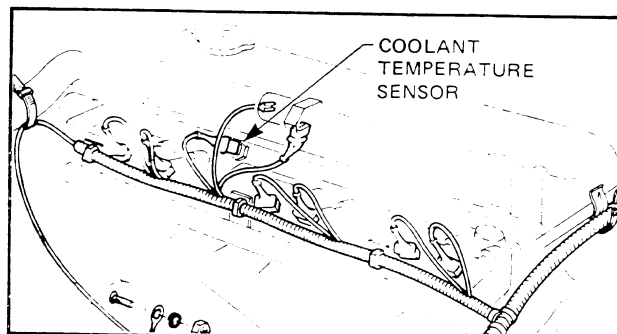

Figure 6C-48

The control unit receives a signal from the coolant temperature sensor and uses it as one of the factors in determining the amount of fuel enrichment required. As coolant temperature rises, the output of the temperature sensor is changed. With this change, the control unit varies the amount of fuel enrichment by changing the duration of the fuel injector opening. Refer Fig. 6C-49. If the sensor is diagnosed as defective, it must be replaced.

NOTE: The coolant temperature sensor for EFI is common with the sensor used for Electronic Spark Timing.

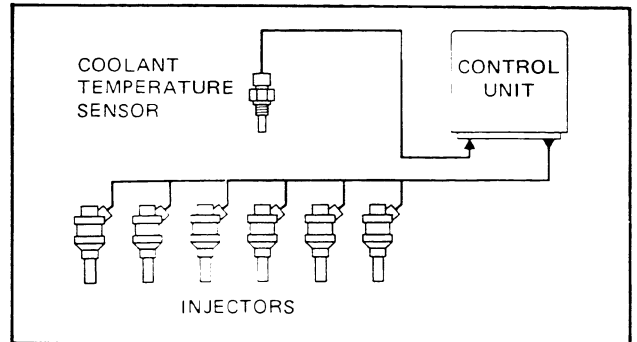

Figure 6C-49

Inlet Air Temperature Sensor

The inlet air temperature sensor is built into the air flow meter housing. Refer Fig. 6C-50. The function of this sensor is to compensate for changes in inlet air temperature by applying a correction to the air flow meter output voltage.

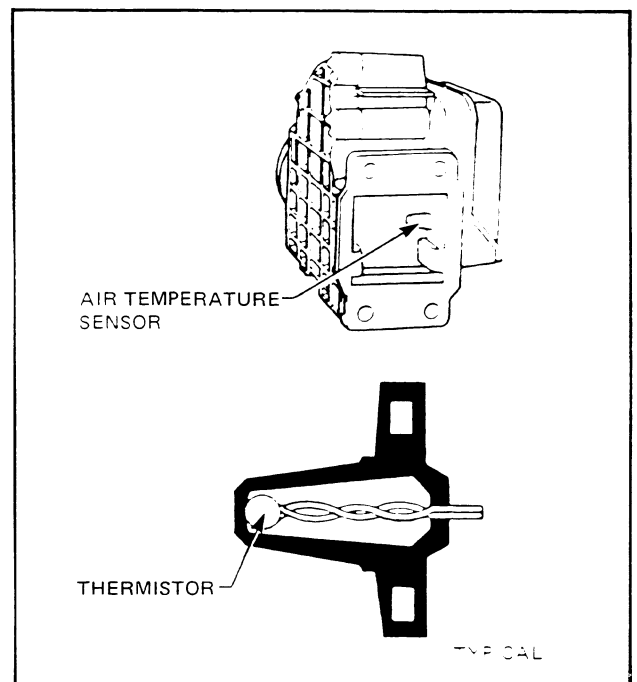

Figure 6C-50

Throttle Position Switch

The throttle position switch is attached to the throttle body and is operated by the movement of the throttle butterfly valve shaft. The switch contains two sets of points, one set monitors closed throttle position and the other set monitors high load position. Refer Fig. 6C-51.

The closed throttle contacts are closed when the throttle butterfly valve is positioned at idle, and are open at any other throttle position.

The closed throttle contacts when closed, provide the control unit with an electrical signal for the deceleration fuel shut off function.

Deceleration condition is detected from the closed throttle contacts and engine rpm above 1800. Under these conditions, which occur while descending hills or slowing down from highway speeds, injection is stopped to save fuel. As the engine slows to 1800 rpm the fuel is reintroduced in preparation for idle.

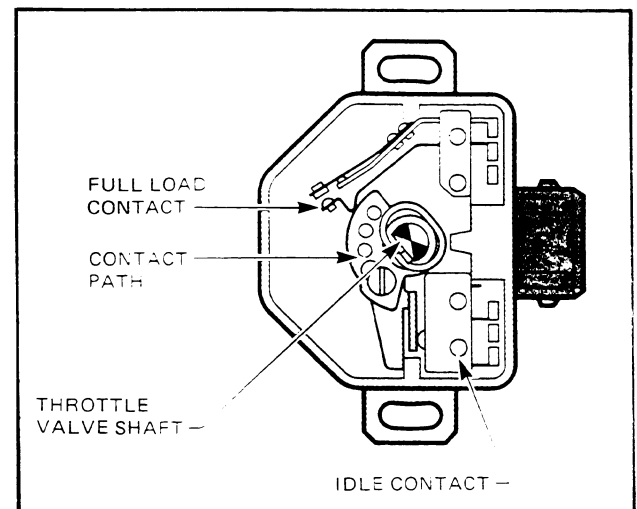

Figure 6C-51

6C-22 ENGINE FUEL

Enrichment is also provided at high load as signalled by the closing contacts in the throttle position switch, when the throttle blade angle exceeds 40° . An electrical signal from the throttle position switch is sent to the control unit to increase the injector pulse width. Refer Fig. 6C-52.

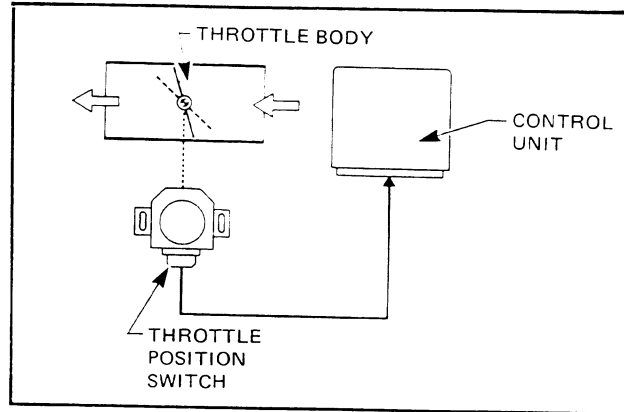

Figure 6C-52

Control Relay

The electrical supply to the fuel pump, control unit, injectors, auxiliary air valve, throttle position switch and air flow meter is controlled by the control relay. The control relay itself is actuated by the ignition switch and also with either:

- The engine cranking.
- The ignition coil pulses being over the equivalent of 150 engine rpm.

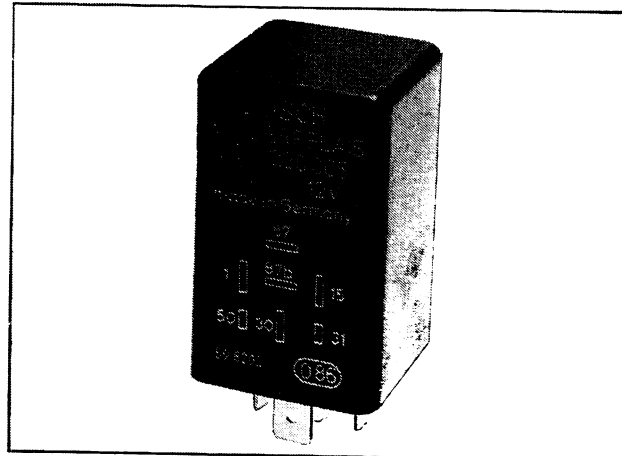

Figure 6C-53

During engine cranking, voltage from the ignition switch and from the starter motor solenoid closes the control relay points. This allows current to flow from the battery, supplying power to the components mentioned above. Refer Fig. 6C-54.

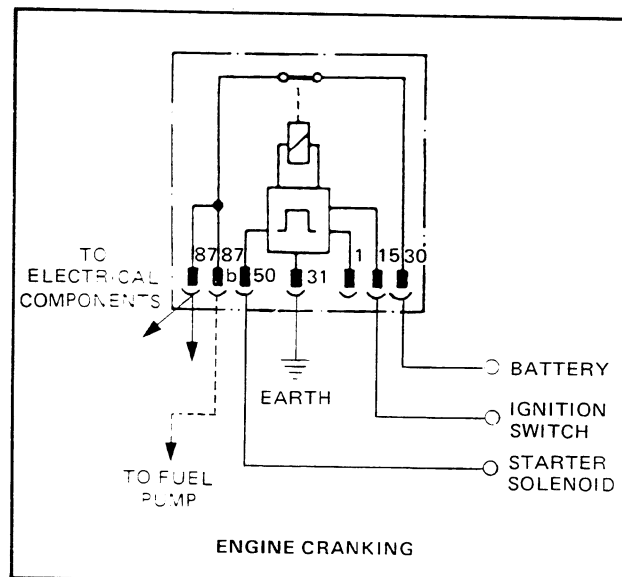

Figure 6C-54

ENGINE FUEL 6C-23

Voltage from the ignition switch is still present at the control relay after the vehicle has started. The rotational speed reached as the engine starts, is high enough to generate the engine running signal, which is taken from the ignition coil pulses being above 150 engine rpm. Refer Fig. 6C-55.

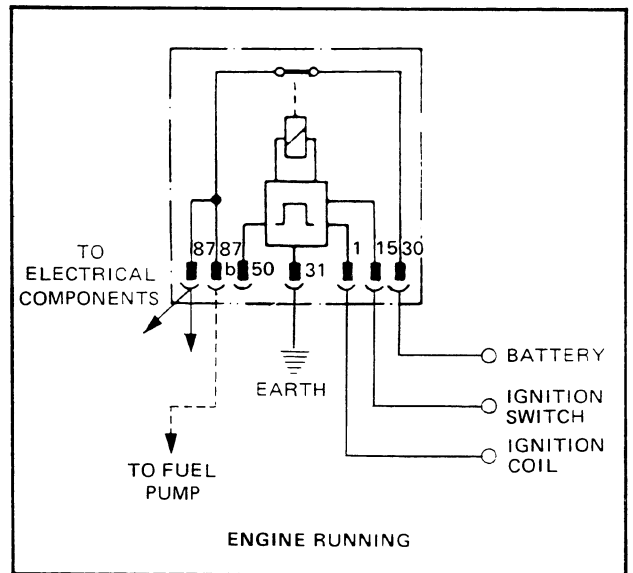

Figure 6C-55

The control relay remains switched on as long as the ignition is switched on and the engine is running.

If the ignition coil pulses stop because the engine has stopped, for instance in the case of an accident, the control relay switches off.

This safety circuit prevents the fuel pump from pumping fuel when the ignition is switched 'ON' but the engine is not running. Refer Fig. 6C-56.

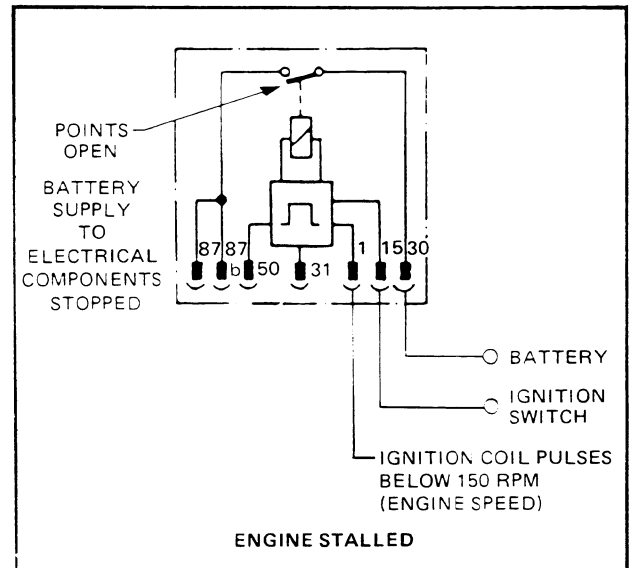

Figure 6C-56

6C-24 ENGINE FUEL

3. SERVICE OPERATIONS

3.1 SERVICE NOTES

IMPORTANT: The following must be observed when working on vehicles with the electronic fuel injection system.

1. Never start the engine without the battery being solidly connected.
2. Do not use a quick charge unit to start the engine.
3. Never separate the battery from the 'on board' electrical system while the engine is running.
4. When charging the battery, disconnect it from the vehicle's electrical system.
5. Before making any test on the fuel injection system, ensure that the ignition coil and distributor are in order, as the control unit operation is triggered from the ignition coil. Checks should also be made of ignition timing and spark plug condition.
6. Never subject the control unit to temperatures above 80°C (176°F) i.e. paint oven, always remove control unit first if this temperature is to be exceeded.
7. Ensure that all cable harness plugs are connected solidly and that battery terminals are thoroughly clean.
8. Never connect or disconnect cable harness plug at control unit when the ignition is switched on.
9. When making a compression test, remove control relay from the fusebox to deactivate the fuel pump and prevent fuel being injected during engine cranking.
10. Depressurize fuel system as per service operation 3.2 in this Section before disconnecting any high pressure fuel line, to reduce the residual pressure in the fuel lines.

NOTE: With very hot engine up to a litre of fuel may be expelled under high pressure.

11. Before attempting any electric welding on the vehicle, disconnect the battery leads and the control unit connector.
12. When steam cleaning engines, do not direct the steam cleaning nozzle at any EFI components. If this happens, corrosion of the terminals can take place.
13. Never attempt to bench test the fuel pump as it is designed to run with the internals immersed in fuel. Running on a bench without any fuel can cause the pump to explode.
14. The throttle body must be removed every 40,000 kms or 2 years whichever occurs first, and Exhaust Gas Recirculation deposits cleaned from the throttle blade and throttle bore. Reset idle speed after reinstallation. Failure to observe this requirement will result in the engine idle speed decreasing and stalling.
15. Disconnect the battery before working on either the fuel or electrical systems of the EFI.
16. Handle all EFI components carefully to avoid damage, particularly the air flow meter.

3.2 FUEL SYSTEM

LEAK TESTING

Prior to starting the engine, following the installation of a fuel system component, check the fuel system for leaks.

1. Check to ensure that there is a sufficient level of fuel in the fuel tank.
2. Activate fuel pump to pressurise system by:
 - a. Disconnect purple lead from starter motor solenoid.
 - b. Hold ignition switch in 'crank' position to run fuel pump.
3. Return ignition to 'off' position.
4. Check fuel system for leaks particularly at points marked ● in Fig. 6C-57.
5. Rectify any fuel leaks.
6. Reconnect lead to starter motor solenoid.

DEPRESSURIZING

The fuel lines of the EFI system retain a residual pressure, even when the engine is switched 'OFF'.

For reasons of safety, it is necessary to depressurize the fuel system before any section on the pressure side of the fuel pump is disconnected.

The system is depressurized, using the hose from fuel pressure gauge part no. SD28018 on the schrader valve fitting at the front of the fuel rail. The end connector of the hose has a built in valve core depressor.

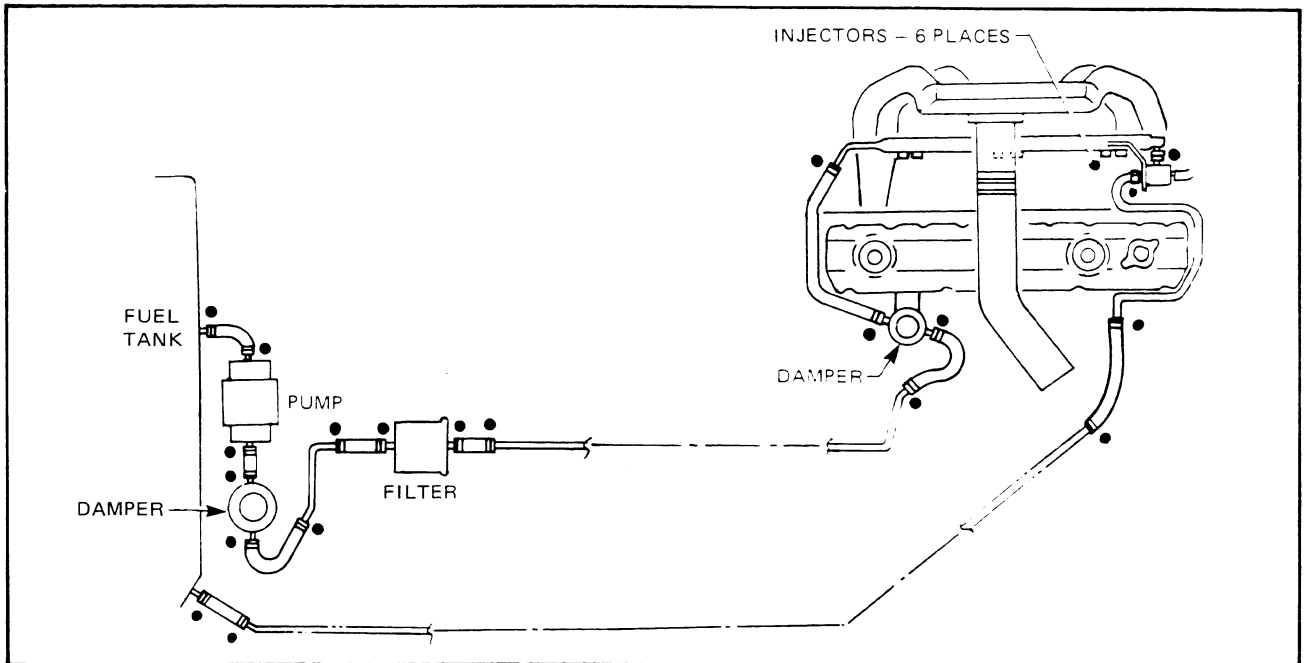

Figure 6C-57

The following procedure should be used when depressurizing the system:-

1. Detach hose from fuel pressure gauge, SD28018.
2. Remove cap from schrader valve fitting in fuel rail.
3. Insert 'Gauge' end of hose into a container with a capacity of at least one litre.
4. **Slowly** install the other end of the hose to the schrader valve fitting and allow fuel to escape into the container (Fig. 6C-57A).
5. When fuel flow ceases, remove hose from fitting and reinstall cap. Reinstall hose to gauge.

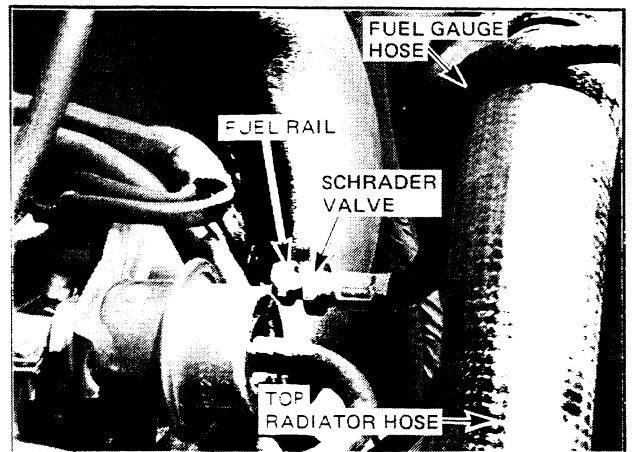

Figure 6C-57A

FUEL HOSES AND CLAMPS

Periodically inspect all fuel hoses for cracks and swelling, replace any hose that shows signs of deterioration.

NOTE: The EFI system uses a special grade of fuel hose that is necessary to withstand the high fuel pressures and temperatures of the system. The diameter of the hose is also matched to the fuel pipes and clamps to ensure positive retention. Use only the correct, genuine EFI system fuel hose. Carburettor fuel hose, emission hose or non genuine hose, even though it may have a high pressure rating, is not suitable.

Hose clamps on the EFI system are specially designed to exert an even clamping force around the circumference of the hose and have rounded edges to avoid cutting into the fuel hose.

Tighten to the correct torque (refer Torque Wrench Specifications) and never use non genuine substitute hose clamps.

6C-26 ENGINE FUEL

3.3 THROTTLE CABLE ADJUSTMENT

1. Depress accelerator pedal to floor.
2. Adjust throttle cable outer lock nuts so that the throttle valve is fully open. Tighten lock nuts to 3.0 to 4.0 Nm (Fig. 6C-58).
3. Allow accelerator pedal to assume free position.
4. Adjust screw on pedal lever so that the pedal has no free play, but the cable is taut and idling speed is not affected. (Fig. 6C-58).

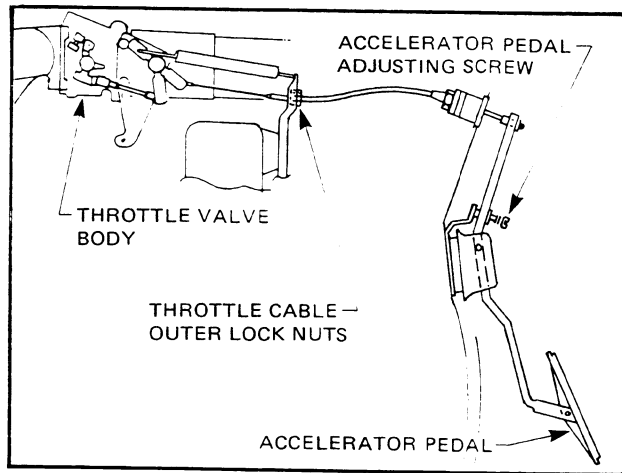

Figure 6C-58

3.4 CRUISE CONTROL POWER UNIT CABLE ADJUSTMENT

1. Ensure ignition is switched 'off' and the throttle butterfly valve is completely closed.
2. Check slack in cable. Refer Fig. 6C-60.
3. To adjust the cable to obtain the correct amount of slack, loosen off lock nut. Refer Fig. 6C-59. Turn the adjusting link to get the desired slack of 5.0 to 10.0 mm as shown in Fig. 6C-60.

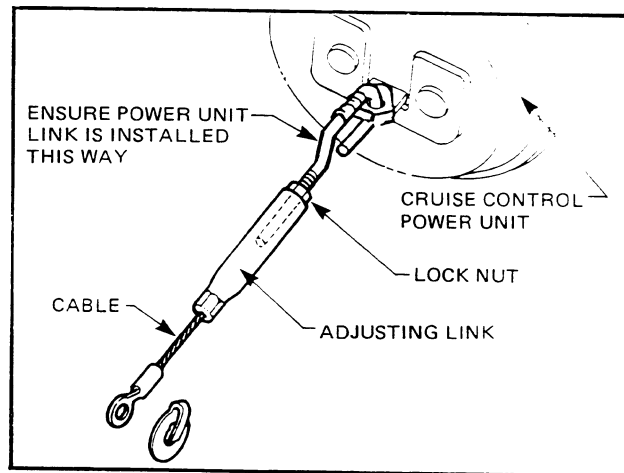

Figure 6C-59

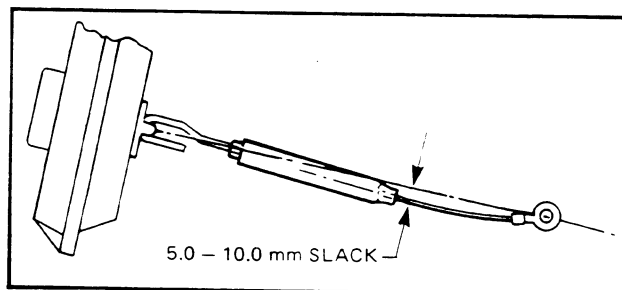

Figure 6C-60

3.5 ADJUSTING IDLE SPEED AND MIXTURE

Before making any adjustments to the idle settings, ensure that:-

1. The engine oil and water are at normal operating temperatures, preferably achieved by driving.
2. Transmission in Park or Neutral.
3. Air conditioning (if fitted) turned off.
4. Disconnect canister purge hose but do not plug (refit after test).

5. Connect an ACCURATE CO-meter and tachometer.
6. Record values and compare to those specified on the Vehicle Emission Control Information Label in the engine compartment and listed in Specifications in this Section.

NOTE: Nominal values are for 'run in' engines. New engines should not be readjusted unless outside the range of 700 to 900 rpm during the first 1500 kms.

The following checks must be performed and any defects corrected before any idle adjustments are made to the EFI system.

1. Ignition timing.
2. Manifold vacuum is present at fuel pressure regulator. (Disconnect vacuum hose at regulator and install vacuum gauge to hose.)
3. Throttle lever closing on to stop - if not check
 - a. Throttle position switch adjustment.
 - b. Throttle linkage and springs.
4. No leaks at hoses and duct between air flow meter and manifold.
5. Running on all cylinders - if not check for
 - a. Defective spark plugs and leads.
 - b. Open circuit to injector.
6. Auxiliary air valve fully shut - check by pinching off air hose and observing engine speed - if speed drops, check for
 - a. Engine not sufficiently warmed up.
 - b. Open circuit in electrical supply to auxiliary air valve.
 - c. Auxiliary air valve installed upside down.

IDLE SPEED ADJUSTMENT

In the case of deviation from specifications, adjust the idle speed as follows:

1. Loosen off lock nut (Fig. 6C-61).
2. Install an accurate tachometer. Turn the idle speed adjusting screw to achieve the correct idle speed Fig. 6C-61.

Screwing the adjuster out, increases the idle speed, screwing in, decreases the idle speed. The specification for a 'run in' engine is:- 850 ± 50 rpm.

DO NOT UNDER ANY CIRCUMSTANCES ADJUST THE THROTTLE LEVER STOP. (Refer Fig. 6C-61).

3. Check CO-reading after speed adjustment. The specification for a 'run in' engine is .5 to 1.5%CO.

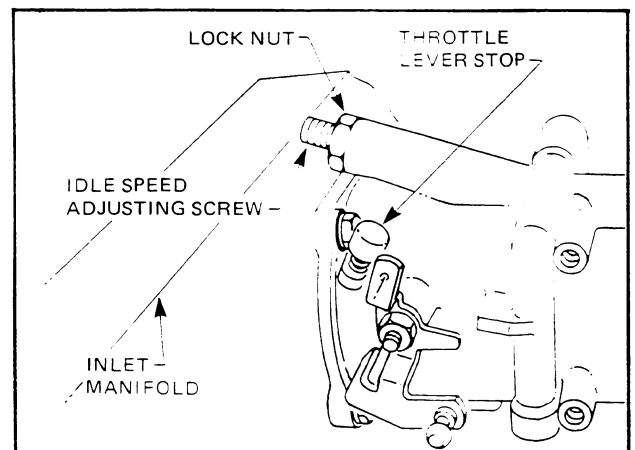

Figure 6C-61

IDLE MIXTURE ADJUSTMENT

This is preset and should not normally be adjusted.

In the case of deviation from specification and all previous checks have been carried out and abnormalities corrected, adjust the idle mixture as follows:-

1. Use only an ACCURATE CO-meter.

6C-28 ENGINE FUEL

2. Pierce and remove the plastic cap on the air flow meter to expose the mixture adjusting screw. Refer Fig. 6C-62.
3. Turning the screw in, richens the mixture, screwing it out leans the mixture. Idle CO-specification is .5 to 1.5%.
4. Recheck idle speed after mixture adjustment.
5. Reseal mixture adjusting screw with a new service, plastic cap.

The service cap is coloured red, and is available from GM P & A, Part Number VS16400.

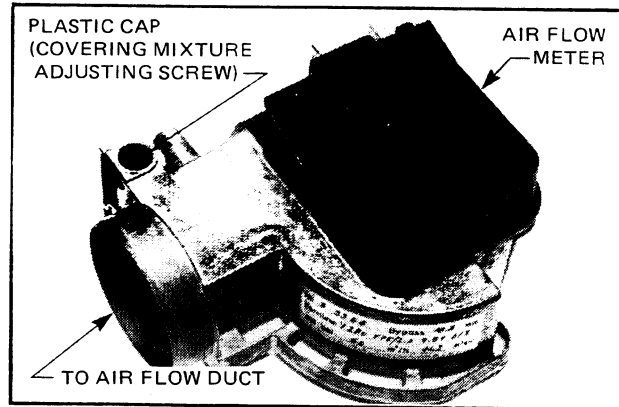

Figure 6C-62

3.6 AIR CLEANER ELEMENT

REPLACEMENT

1. Disconnect battery earth lead.
2. Loosen hose clamp around air flow duct at air flow meter. Refer Fig. 6C-63.
3. Disconnect wiring harness connector at the air flow meter, remove harness from retainer. Refer Fig. 6C-63.

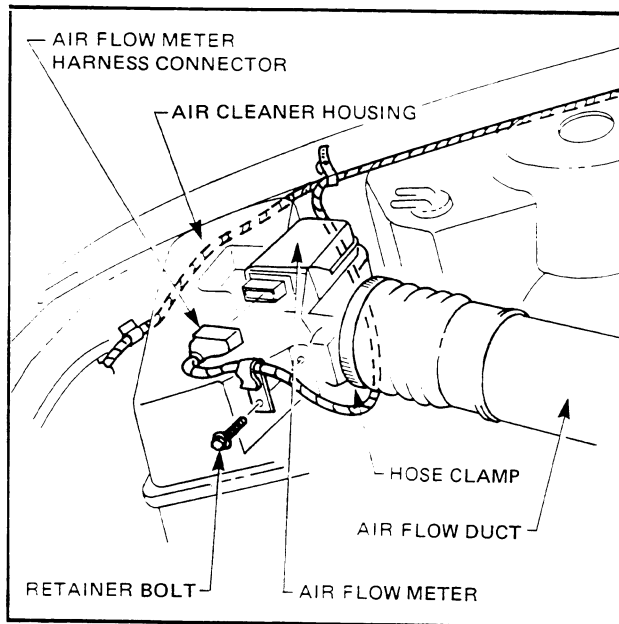

Figure 6C-63

4. Remove air flow duct mounting bolt. Refer Fig. 6C-63A.

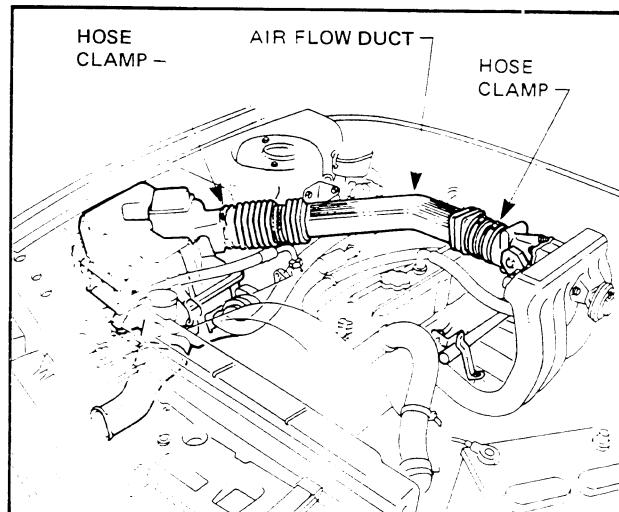

Figure 6C-63A

5. Unclip snap locks around upper air cleaner housing. Refer Fig. 6C-64.
6. Lift upper air cleaner housing from its position and remove from air flow duct.

NOTE: When removing the upper air cleaner housing, be particularly careful not to damage or knock the air flow meter.

7. Remove air cleaner element from upper housing.

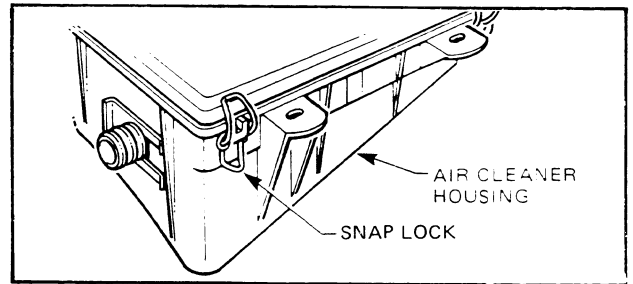

Figure 6C-64

8. Fit new air cleaner element into upper housing and check that it is seated correctly. Refer Fig. 6C-65. Refit upper housing, wiring connector battery lead and air flow duct hose clamp.

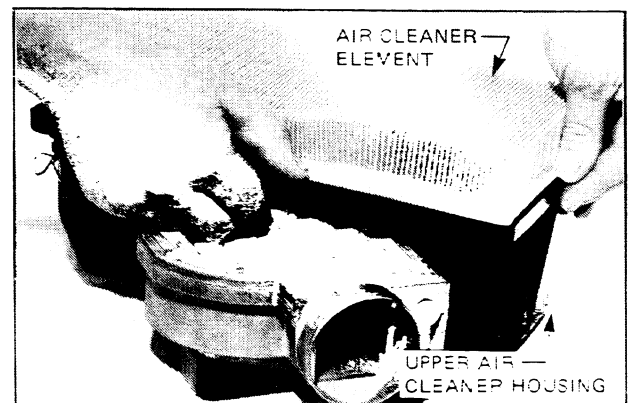

Figure 6C-65

3.7 AIR CLEANER HOUSING

REMOVE

1. Disconnect battery earth lead.
2. Disconnect wiring harness connector at the air flow meter, remove harness from retainer. Refer Fig. 6C-66.
3. Loosen the hose clamp around air flow duct at air flow meter. Refer Fig. 6C-66.

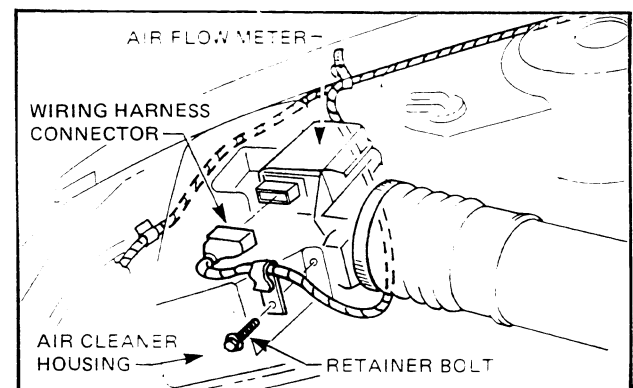

Figure 6C-66

4. Remove engine ventilation hose from the lower inner panel of the air cleaner housing. Refer Fig. 6C-67.

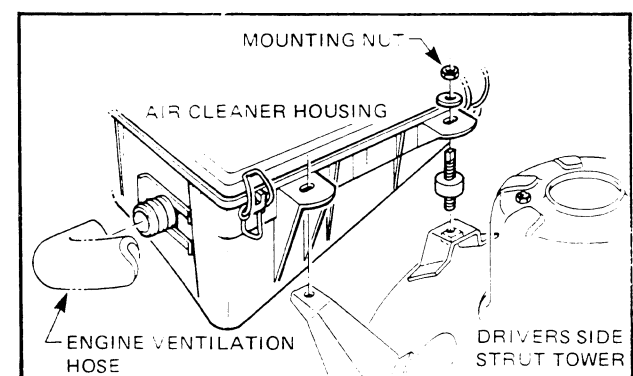

Figure 6C-67

6C-30 ENGINE FUEL

5. Remove air flow duct mounting bolt. Refer Fig. 6C-67A.
6. Remove the three air cleaner housing mounting nuts (refer Fig. 6C-66) and withdraw air cleaner housing by first sliding the air flow meter from the air flow duct and then removing the housing assembly.

REINSTALL

1. Installation is reversal of removal.
2. Check for air leaks.

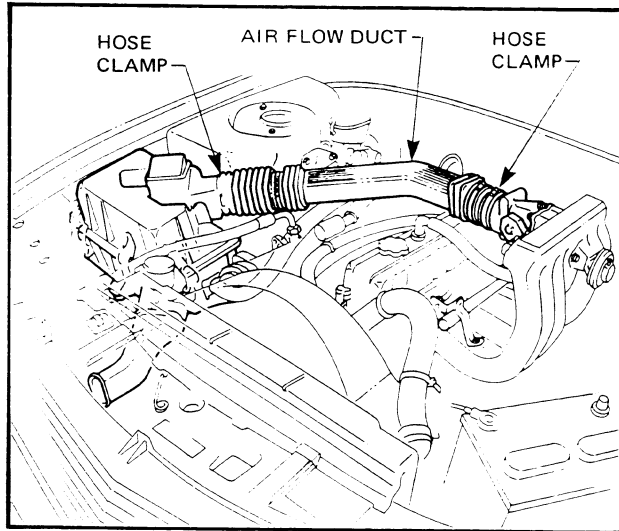

Figure 6C-67A

3.8 AIR FLOW METER

REMOVE

1. Disconnect battery earth lead.
2. Loosen hose clamp around air flow duct at air flow meter. Refer Fig. 6C-68.
3. Disconnect wiring harness connector at the air flow meter, remove harness from retainer. Refer Fig. 6C-68.

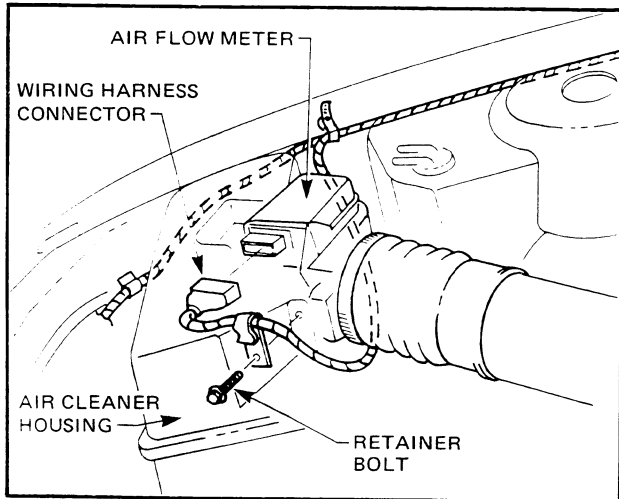

Figure 6C-68

4. Remove air flow duct mounting bolt. Refer Fig. 6C-68A.

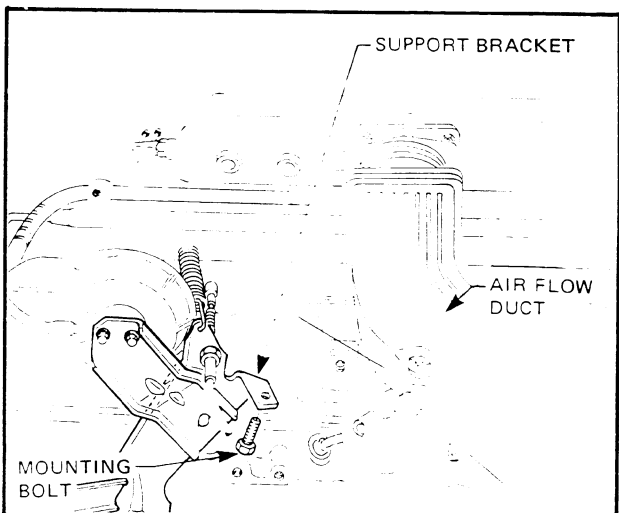

Figure 6C-68A

5. Open snap locks and remove air flow meter with upper section of air cleaner housing. Refer Fig. 6C-69.
6. Remove air flow meter harness retainer bolt. Refer Fig. 6C-68.
7. Remove air cleaner element from upper housing.

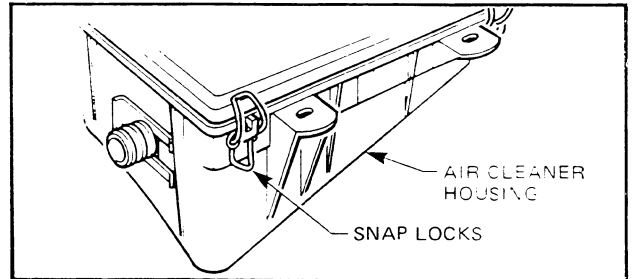

Figure 6C-69

8. Remove air flow meter mounting bolts from upper inner air cleaner housing. Refer Fig. 6C-70.

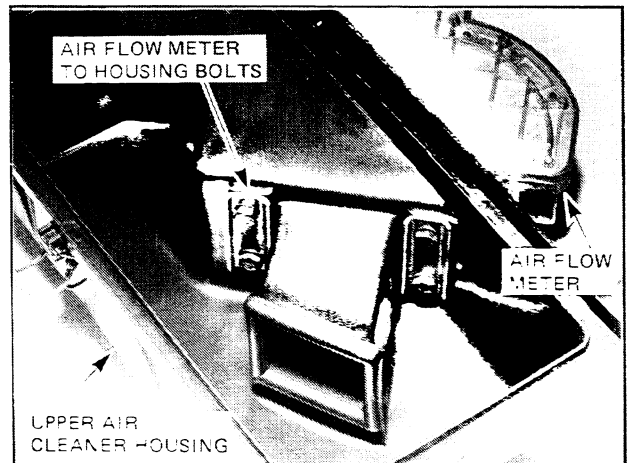

Figure 6C-70

NOTE: A square 'O' ring is used to seal between the air flow meter and air cleaner housing. Refer Fig. 6C-71.

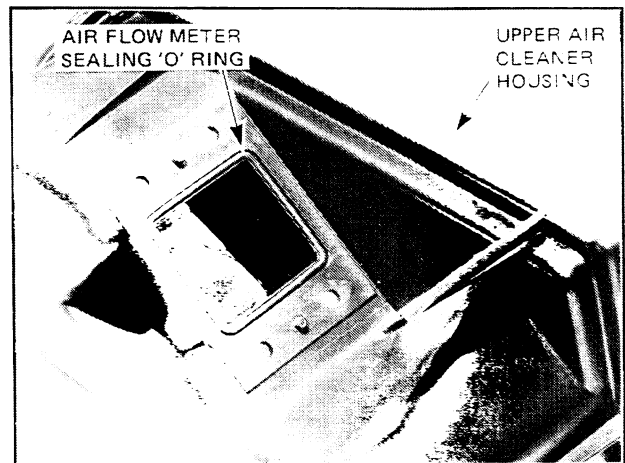

Figure 6C-71

REINSTALL

1. Installation is reversal of removal.
2. Ensure 'O' ring is in place.
3. Check air flow meter flap for correct functioning by moving it all the way to the stop. The movement must not be jerky.
4. Use a clean lint free cloth to remove any dirt in the area of the flap.

DO NOT use any solvent or compressed air to clean the passage of the air flow meter.

5. Tighten air flow meter mounting bolts, and the wiring harness retainer bolt.
6. Refit air cleaner element to upper housing.
7. Check for air leaks.

6C-32 ENGINE FUEL

TEST

If the following test is to be conducted on the vehicle, disconnect the battery earth lead and the wiring harness connector at the air flow meter.

1. Measure the resistance between terminals 7 and 5 while sliding the air flow flap. If the resistance is at any value other than 0 and infinity, air flow meter is normal. Refer Fig. 6C-72.

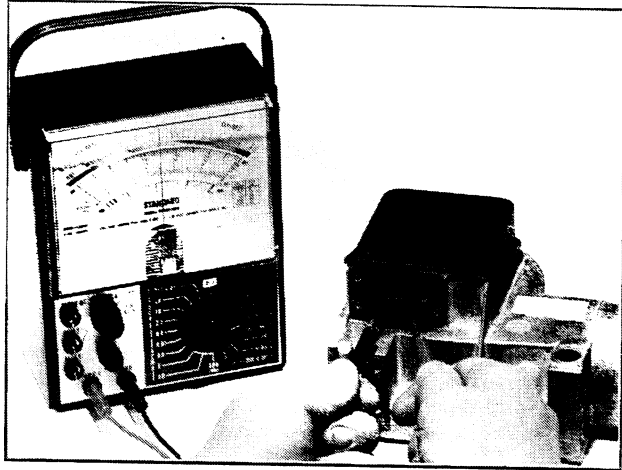

Figure 6C-72

2. Check insulation resistance between the air flow meter body and any of the terminals. If continuity exists, the air flow meter is defective and must be replaced. Refer Fig. 6C-73.

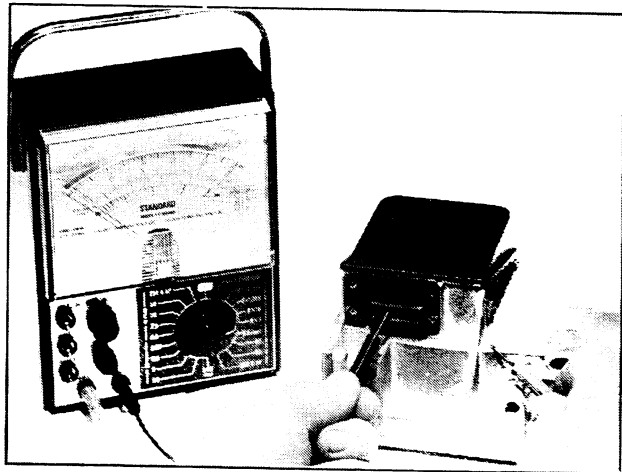

Figure 6C-73

3.9 AIR FLOW DUCT

REMOVE

1. Disconnect battery earth lead.
2. Loosen hose clamp and remove hose to the auxiliary air valve from the air flow duct. Refer Fig. 6C-74.

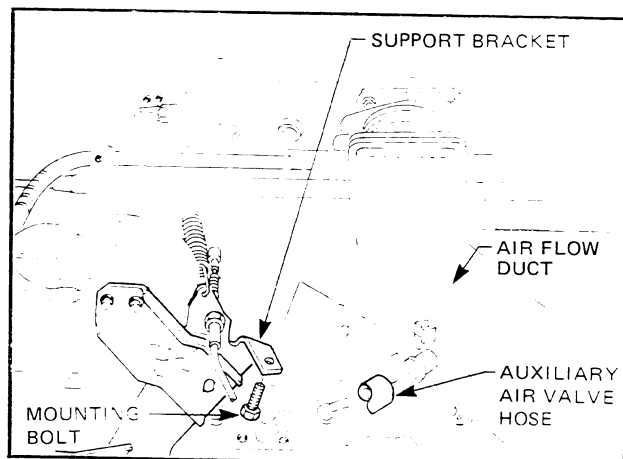

Figure 6C-74

3. Remove the engine ventilation hose bracket bolt from underneath air flow duct. Refer Fig. 6C-74A.
4. Remove the air flow duct mounting bolt from support bracket. Refer Fig. 6C-74.

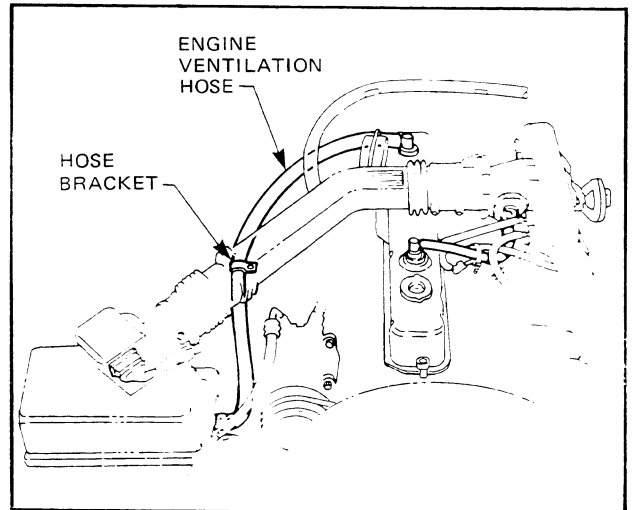

Figure 6C-74A

5. Loosen the hose clamps around each end of the air flow duct (refer Fig. 6C-75) and withdraw duct from its position.

REINSTALL

1. Installation is reversal of removal.
2. Check for air leaks at all connections to air flow duct (this will effect the air fuel ratio).

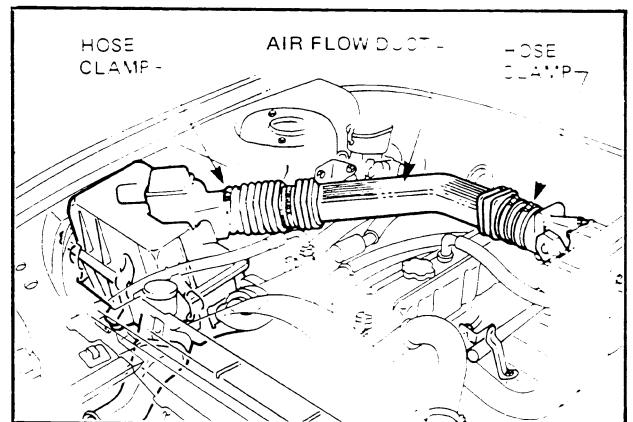

Figure 6C-75

3.10 THROTTLE BODY

REMOVE

1. Disconnect battery earth lead.
2. Remove air flow duct as per 3.9.
3. Disconnect throttle cable from throttle body linkage and air flow duct mounting bracket. Remove the upper accelerator return spring. Refer Fig. 6C-76.

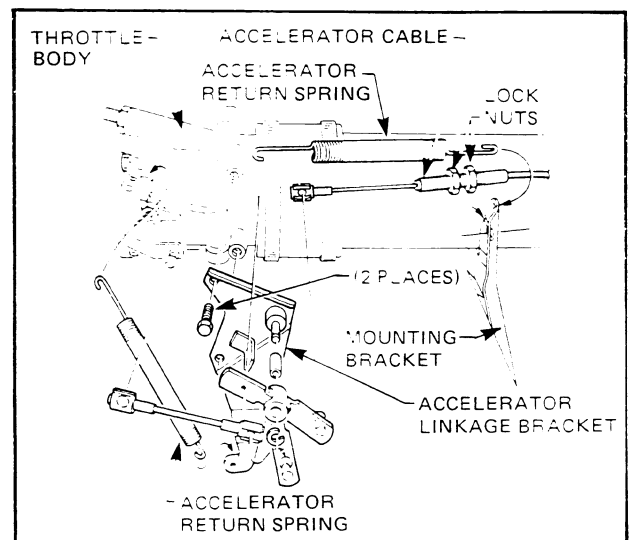

Figure 6C-76

6C-34 ENGINE FUEL

4. If fitted, remove cruise control power unit cable retainer from throttle linkage. Refer Fig. 6C-77.

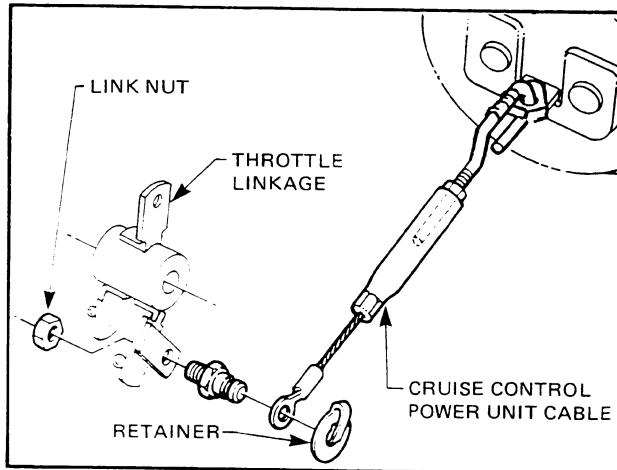

Figure 6C-77

5. Disconnect vacuum hoses to throttle body, noting positions for correct reinstallation. Refer Fig. 6C-78.

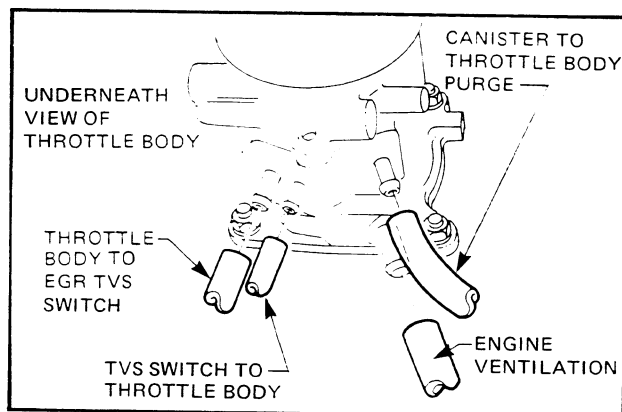

Figure 6C-78

6. Disconnect throttle position switch wiring harness connector and, if fitted, idle load compensator power feed wire. Refer Fig. 6C-79.
7. Remove the 4 mounting nuts securing throttle body to the inlet manifold and remove throttle body and gasket. Refer Fig. 6C-79.
8. Remove the two bolts securing the throttle linkage bracket to the throttle body and disconnect the throttle rod from the throttle lever ball. Refer Fig. 6C-76.

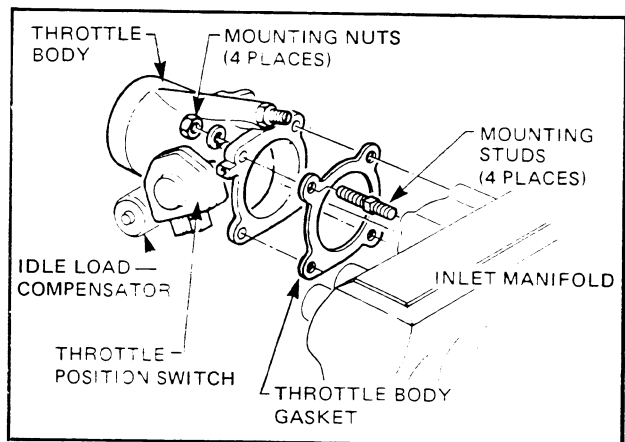

Figure 6C-79

REINSTALL

Installation is reversal of removal noting the following:

Use a new throttle body to inlet manifold gasket.

Before fitting the throttle body wipe Exhaust Gas Recirculation deposit from the throttle blade and bore. Blow out the small drillings for the spark, EGR and canister signals with compressed air.

NOTE: Reset the idle speed on reinstallation after cleaning, refer 3.5.

Check for full throttle and adjust throttle cable as required, refer 3.3.

If fitted with cruise control, check cruise control power unit cable adjustment, refer 3.4.

Start engine and check for air leaks.

3.11 INLET MANIFOLD

REMOVE

1. Disconnect battery earth lead.
2. Remove air flow duct as per 3.9.
3. Disconnect all vacuum hoses from inlet manifold and throttle body and remove inlet manifold vacuum adaptor from rear of manifold.

NOTE: Observe hose positions for correct reinstallation refer Figs. 6C-80, 6C-81.

HOSE NOS.

- | | |
|----|---|
| 1 | To speed sensor transducer. |
| 15 | To 104°C thermostat housing TVS. |
| 2 | To brake booster. |
| 4 | To auxiliary air valve. |
| 5 | To automatic transmission vacuum modulator valve. |
| 3 | To fuel pressure regulator valve. |
| 55 | EGR valve to cylinder head EGR TVS switch. |

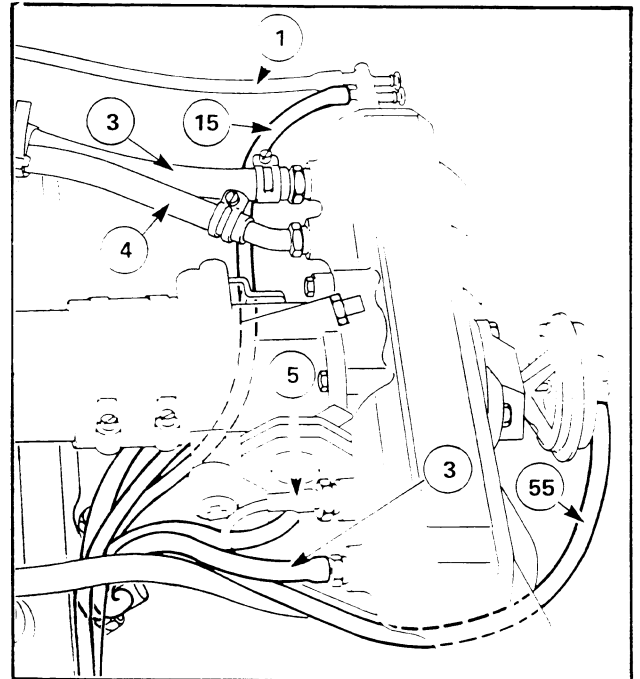

Figure 6C-80

HOSE NOS.

- | | |
|----|--|
| 61 | Throttle body to cylinder head EGR TVS switch. |
| 38 | Throttle body to thermostat housing TVS. |
| 60 | Canister to throttle body purge. |
| 6 | Engine ventilation hose. |

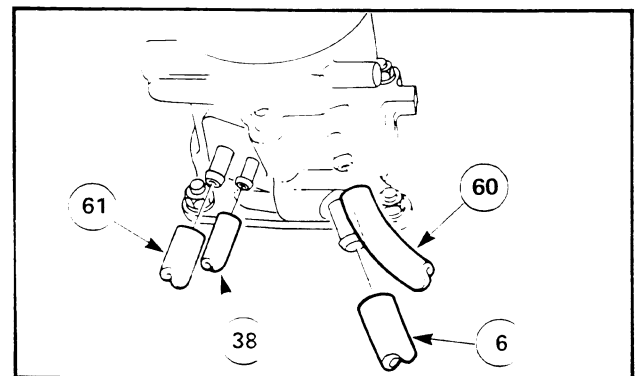

Figure 6C-81

4. Disconnect throttle cable from throttle body linkage and air flow duct mounting bracket. Remove the upper accelerator return spring. Refer Fig. 6C-82.

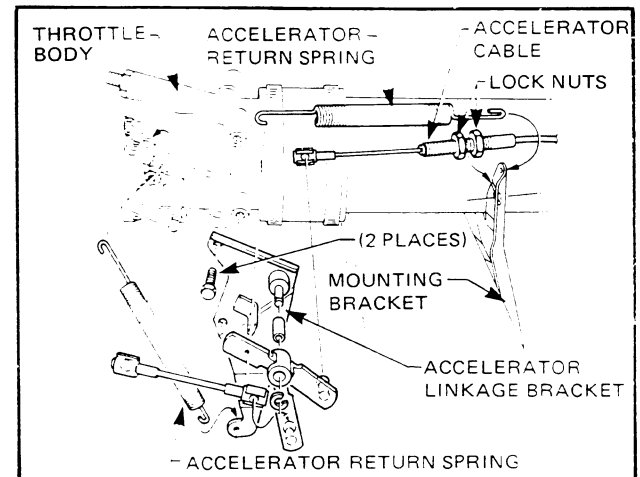

Figure 6C-82

6C-36 ENGINE FUEL

5. If fitted, remove cruise control power unit cable retainer from throttle linkage. Refer Fig. 6C-83.

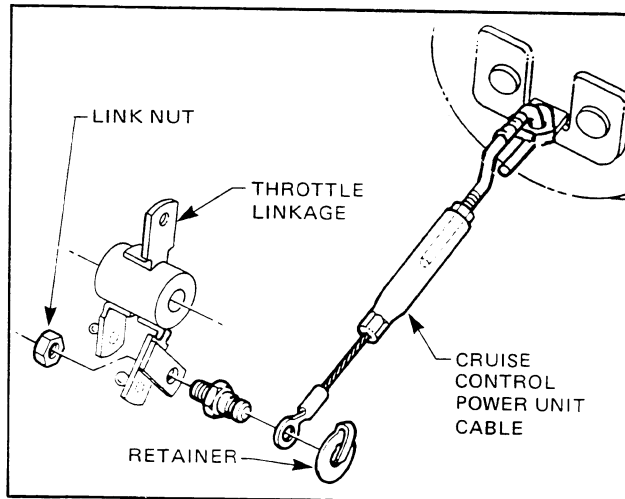

Figure 6C-83

6. Disconnect wiring harness connectors from the throttle position switch, idle load compensator if fitted, coolant temperature sensor, injectors and generator. Refer Fig. 6C-84.

Unclip wiring harness clips around fuel rail and top radiator hose and withdraw wiring harness towards the rear of the engine.

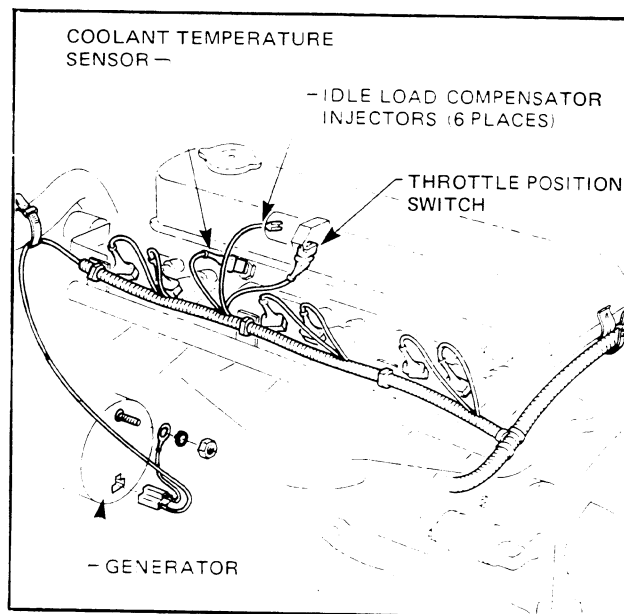

Figure 6C-84

7. Disconnect E.G.R. pipe from inlet and extractor manifolds. Refer Fig. 6C-85.
8. Depressurize fuel system as per 3.2.
9. Disconnect fuel rail hose and fuel return hose from fuel regulator.

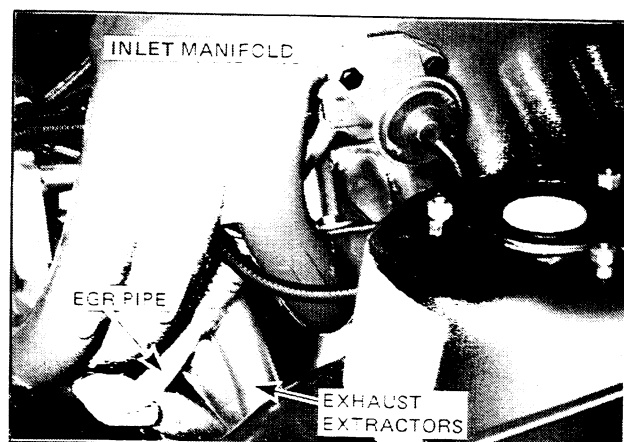

Figure 6C-85

10. Remove inlet manifold brace bar. Refer Fig. 6C-86.
11. Remove manifold to cylinder head attaching nuts and bolts.
12. Release inlet manifold from cylinder head. Once clear of manifold mounting studs, remove manifold and feed the automatic transmission modulator pipe from the manifold.

REINSTALL

Clean inlet manifold and cylinder head mating faces and E.G.R. exhaust gas pipe and manifold surfaces. Install new gaskets.

Installation is reverse of removal operations. Tighten manifold bolts, working from the centre outwards. Refer Torque Wrench Specification for details.

Install inlet manifold brace after torquing up the manifold to head nuts and bolts. Tighten the top end of the brace first to ensure the slotted end is correctly positioned on the extended head bolt.

Test fuel system for leaks as per instruction 3.2 and check full throttle and adjust throttle cable as required, refer 3.3.

If fitted with cruise control, check cruise control power unit cable adjustment, refer 3.4.

Start engine and check for air leaks.

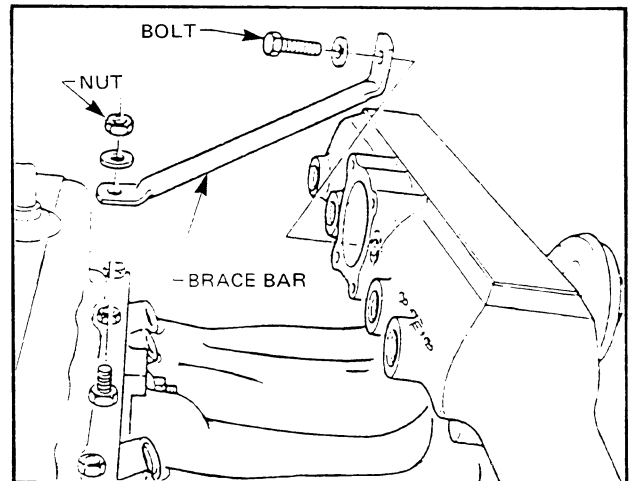

Figure 6C-86

3.12 AUXILIARY AIR VALVE

REMOVE

1. Disconnect battery earth lead.
2. Disconnect harness plug at top of valve. Refer Fig. 6C-87.
3. Loosen hose clamps at each end of the valve and disconnect hoses. Refer Fig. 6C-87.
4. Unscrew both mounting screws and remove auxiliary air valve. Refer Fig. 6C-87.

REINSTALL

1. Installation is reversal of removal. Valve is to be installed with the wiring plug connection upwards. Ensure that the cylinder head and auxiliary air valve mating surfaces are clean to provide the required heat transfer.
2. Check for air leaks.

TEST

This test must be performed with a cold engine.

Start engine and pinch the rubber hose between the throttle body and the air valve.

When the air valve is cold, the engine speed should decrease as the hose is pinched.

With the air valve hot, the engine speed remains unchanged as the hose is pinched.

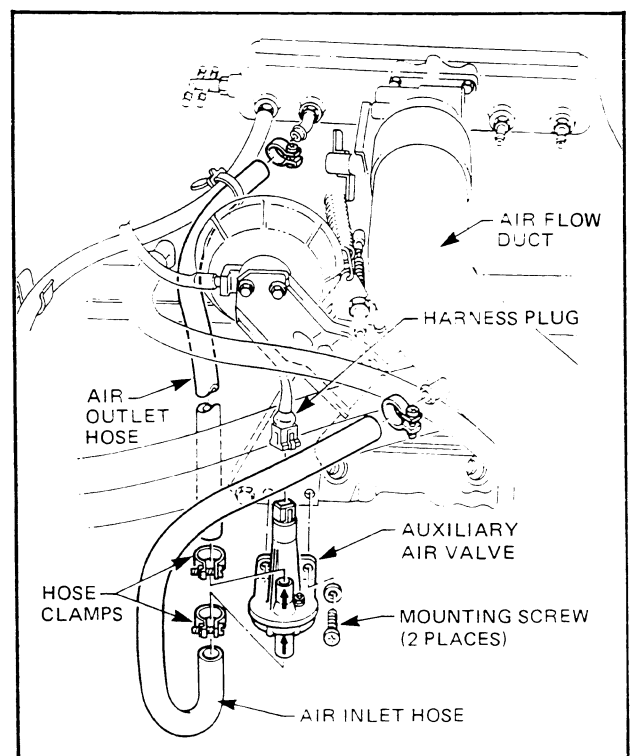

Figure 6C-87

6C-38 ENGINE FUEL

3.13 FUEL PUMP

REMOVE

1. Disconnect battery earth lead.
2. Drain tank to below level of fuel outlet.
3. Disconnect wiring harness connections on the pump. Note which way the wiring connectors are fitted to the pump. Refer Fig. 6C-88.
4. Place a drain tray underneath pump.
5. Depressurize fuel system as per 3.2.
6. Remove fuel pump clamp bolt and clamp. Refer Fig. 6C-88.
7. Loosen hose clamps at either end of the fuel pump and slide hoses off, withdraw fuel pump. Fig. 6C-88.

REINSTALL

Installation is reversal of removal. When installing the fuel pump ensure that the fuel line hose clamps are properly seated and check for fuel leaks as per 3.2.

TESTING

Volume Test

1. Depressurize fuel system as per 3.2.
2. Remove gauge hose from fuel rail, and using a schrader valve remover, remove valve core. Refit gauge hose to schrader valve fitting.
3. Place free end of gauge hose in a container with a volume measurement scale.

NOTE: Ensure the container has a volume greater than 1 litre and that fuel tank has a sufficient level of fuel.

4. Remove purple lead from starter motor solenoid.
5. Activate fuel pump by switching ignition to the 'START' position.
6. The volume pumped should be at least one litre in 30 seconds. If the volume pumped is not sufficient:
 - a. Jack up rear of vehicle and place on safety stands.
 - b. Disconnect fuel hose between fuel pump and fuel filter at the fuel pump end. Install one end of a suitable length of fuel hose to the fuel pump outlet pipe and insert the end in a container with a volume measurement scale of at least 1 litre capacity.
7. Retest as per steps 5 and 6.
If volume pumped is sufficient, fuel filter is blocked.
8. If volume pumped is not sufficient:
 - a. Remove fuel pump inlet pipe, install a test hose to the fuel pump inlet. Immerse hose in a container having more than a litre of **clean** fuel.
 - b. Place the fuel pump outlet test hose in the empty test container.
9. Retest as per steps 5 and 6.
If volume pumped is sufficient, the fuel tank sender unit stainer is blocked. Remove tank unit as per instruction 2.6 in Section 8A of this Supplement.
If volume pumped is not sufficient, replace fuel pump.

Pressure Test

1. Install fuel pressure gauge and hose (Part no. SD28018) to schrader valve fitting at front of fuel rail (Fig. 6C-89). Hose has built in valve core depressor.

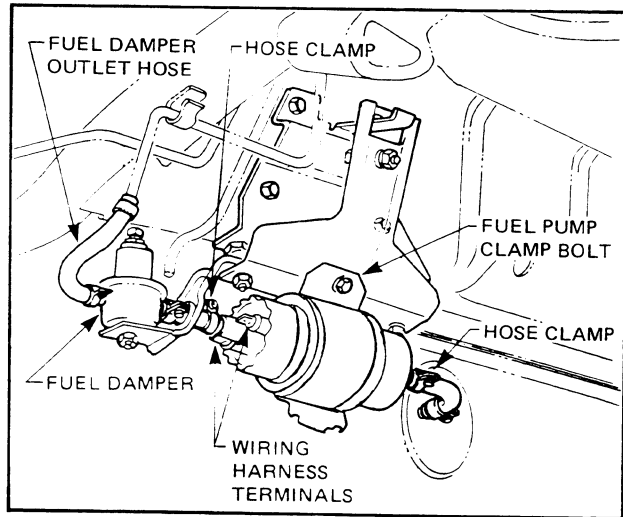

Figure 6C-88

2. Start engine and read fuel pressure gauge.
Pressure should be approximately 250 ± 20 kPa at idle.
The moment the accelerator pedal is moved pressure should increase to approximately 300 kPa (accelerator must be opened rapidly to give '0' manifold vacuum).
3. If fuel pressure is not as specified, check for clogged or deformed fuel lines, blocked fuel filter or pick up strainer.
4. If above the specified value, check condition and connection of vacuum hose to pressure regulator, if hose is satisfactory, replace regulator and retest. If the pressure is still not achieved, replace fuel pump.

Fuel Pressure Test - For Internal Leakage

1. Install fuel pressure gauge part no. SD28018 as per previous test.
2. Start engine and allow to idle, note fuel pressure gauge reading.
3. Switch engine 'off' and observe pressure gauge reading. If the reading drops, it is an indication of an internal fuel leakage.
4. Under the vehicle, clamp the fuel pump outlet hose. Observe the fuel pressure gauge reading. If the reading stops dropping, the fuel pump has an internal fuel leakage and must be replaced.
5. If the reading continues to drop, while the hose is clamped, remove the purple lead from the starter motor solenoid. Turn the ignition to the 'START' position and allow the fuel pump to run. Once the fuel pressure reading has reached the same as recorded in step 2, switch 'off' ignition.
6. Clamp the fuel return line from the pressure regulator and observe the pressure gauge reading. If the reading stops dropping, the pressure regulator is faulty and must be replaced.
7. If the reading continues to drop, remove the fuel rail mounting bolts from inlet manifold.
8. Carefully remove fuel rail and injectors from the inlet manifold and rest the fuel rail on the manifold.
9. Carry out step 5.
10. Observe which injector/s is leaking.
11. Replace injector/s which are faulty. Replace the sealing 'O' rings on all other injectors, and lubricate using petroleum jelly.
12. Refit fuel rail assembly.
13. Refit starter motor solenoid wire. Start engine and check fuel pressure gauge reading. Switch 'off' engine and check for pressure drop.
14. Remove pressure gauge and install scrapper valve cap.

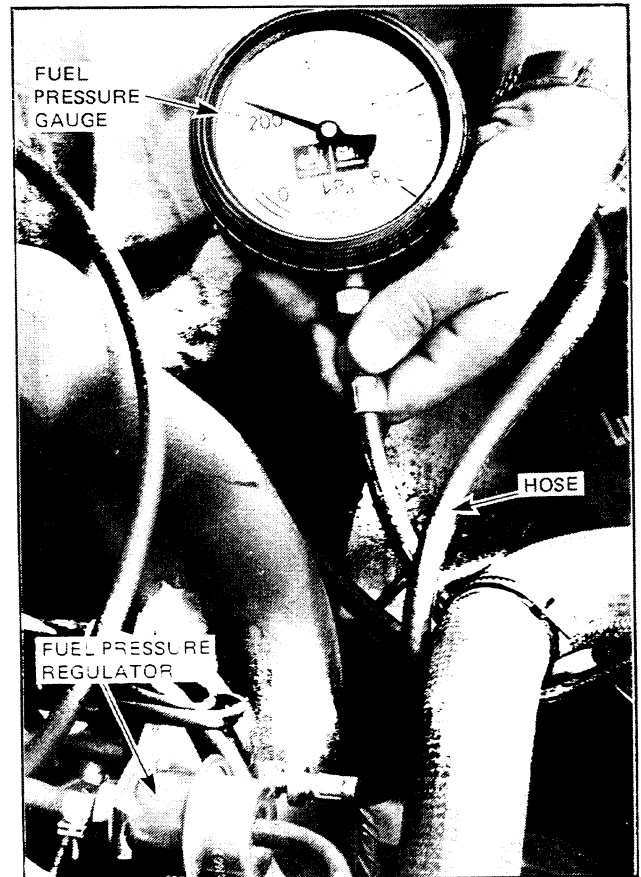

Figure 6C-89

6C-40 ENGINE FUEL

3.14 FUEL DAMPER - REAR

REMOVE

1. Disconnect battery earth lead.
2. Depressurize fuel system as per 3.2.
3. Raise rear of vehicle and support on jack stands.
4. Loosen hose clamp on fuel outlet hose from damper, remove hose. Refer Fig. 6C-90.
5. Remove fuel damper mounting nut from bracket, loosen hose clamp between damper and fuel pump. Refer Fig. 6C-90.
6. Lift damper from mounting bracket and withdraw from fuel pump hose.

REINSTALL

1. Installation is reversal of removal.
2. Check for fuel leaks as per 3.2.

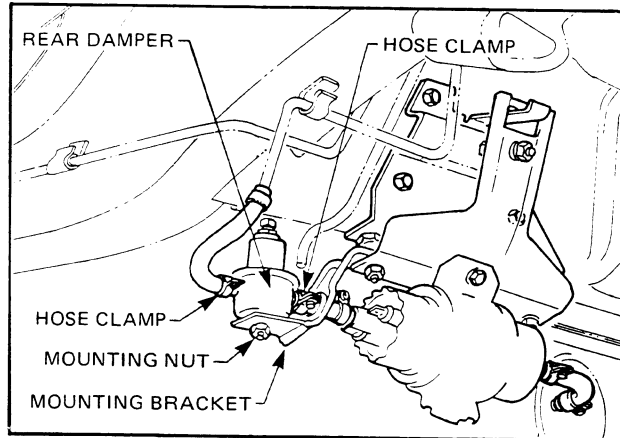

Figure 6C-90

3.15 FUEL FILTER

REMOVE

1. Disconnect battery earth lead.
2. Depressurize fuel system as per 3.2.
3. Raise rear of vehicle and support on jack stands.
4. Place a drain tray underneath filter.
5. Loosen hose clamps and disengage fuel hoses from filter. Refer Fig. 6C-91.
6. Loosen filter mounting clamp bolt and remove filter. Refer Fig. 6C-91.

REINSTALL

1. Replacing filter is reversal of removal.

NOTE: Direction of fuel flow arrow on filter body must be complied with (arrow to point to front of vehicle).

2. Make sure the fuel line hose clamps are properly seated and check for fuel leaks. refer instruction 3.2.

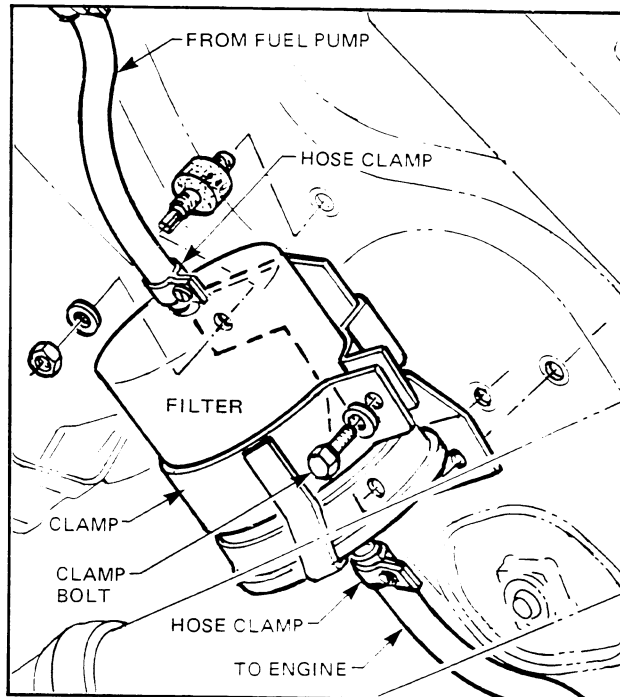

Figure 6C-91

3.16 FUEL DAMPER - FRONT

REMOVE

1. Disconnect battery earth lead.
2. Depressurize fuel system as per 3.2.
3. Loosen fuel line hose clamps at each side of damper, disconnect fuel hoses. Refer Fig. 6C-92.
4. Remove mounting nut. Refer Fig. 6C-92 and withdraw damper.

REINSTALL

1. Installation is reversal of removal.
2. Check for fuel leaks as per 3.2.

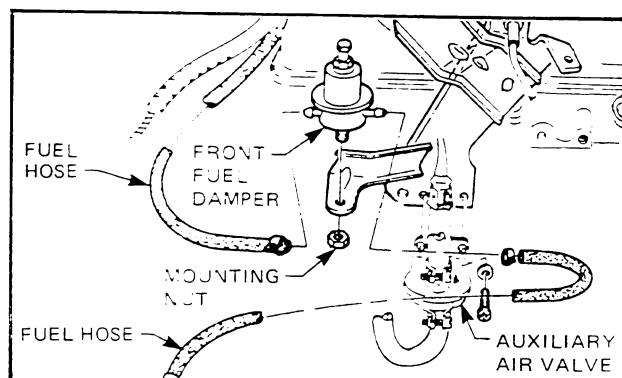

Figure 6C-92

3.17 FUEL RAIL

REMOVE

1. Disconnect battery earth lead.
2. Depressurize fuel system as per 3.2.
3. Disconnect the fuel return line from the fuel pressure regulator, disconnect vacuum hose to the regulator.
4. Disconnect wiring harness connectors at the throttle position switch, idle load compensator if fitted, coolant temperature sensor, injectors and generator wiring. Refer Fig. 6C-93. Unclip wiring harness retaining clips around fuel rail and top radiator hose, and withdraw wiring harness to the rear of the inlet manifold.
5. Remove the bolt securing the inlet manifold brace bar at the manifold and the nut on top of the cylinder head stud. Remove brace bar. Refer Fig. 6C-94.
6. Remove the injector retaining clips. Refer Fig. 6C-95.

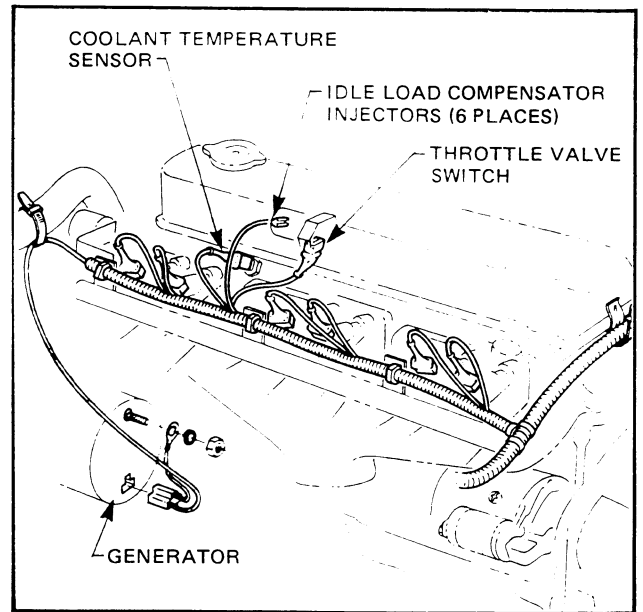

Figure 6C-93

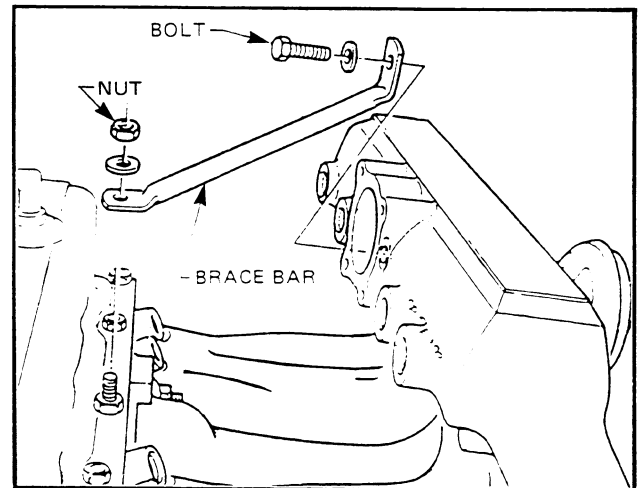

Figure 6C-94

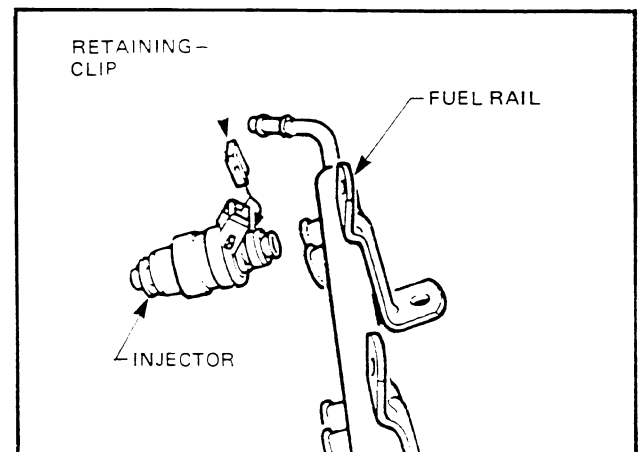

Figure 6C-95

6C-42 ENGINE FUEL

7. Remove the 3 fuel rail mounting bolts. Refer Fig. 6C-95. Using compressed air, blow off dirt around the injectors.
8. Pull fuel rail towards the inlet manifold and CAREFULLY loosen injectors from the inlet manifold or fuel rail.
9. Remove all injectors and place in a clean location.
10. Withdraw fuel rail toward front of engine, pushing down slightly on top radiator hose.

REINSTALL

Before reinstalling any injector, replace both sealing 'O' rings. It will be necessary to cut the old 'O' rings from the injectors. Take care not to damage the tip insulator. Smear the sealing 'O' rings with petroleum jelly. Insert each injector into the fuel rail, then install retaining clips. With all injectors in fuel rail, carefully position numbers 5 and 6 cylinder injectors into the manifold ports. Next, position the centre two injectors, then the remaining two injectors.

With all injectors correctly positioned in the manifold, push fuel rail squarely in to fully engage injectors.

Installation is reversal of removal. Check for fuel leaks as per 3.2.

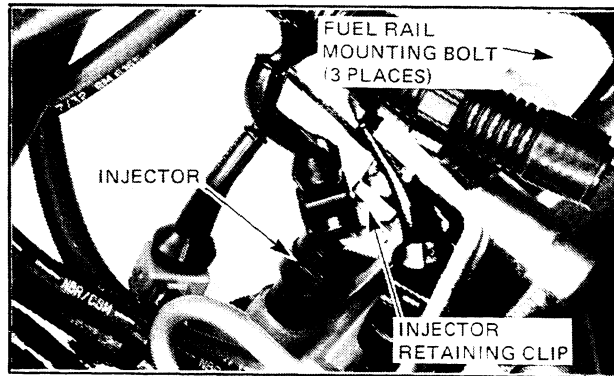

Figure 6C-96

3.18 INJECTORS

For removal and reinstalling instructions, refer to Fuel Rail Remove and Reinstall, 3.17.

3.19 PRESSURE REGULATOR

REMOVE

1. Disconnect battery earth lead.
2. Disconnect vacuum hose at the pressure regulator. Refer Fig. 6C-97.
3. Depressurize fuel system as per 3.2.
4. Disconnect the fuel connections to and from the pressure regulator. Refer Fig. 6C-97.
5. Remove regulator mounting nut on fuel rail bracket and remove regulator. Refer Fig. 6C-97.

REINSTALL

1. Installation is reversal of removal.
2. Check for fuel leaks as per instruction 3.2.

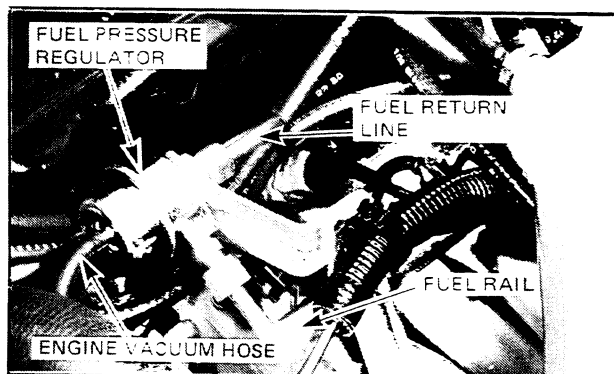

Figure 6C-97

3.20 CONTROL UNIT

REMOVE

1. Make sure ignition is switched 'OFF' and disconnect battery earth lead.
2. Remove the left hand cowl panel trim from the front passenger compartment, as described in Section 1A of this Supplement.

3. Remove the two control unit mounting screws. Refer Fig. 6C-98.

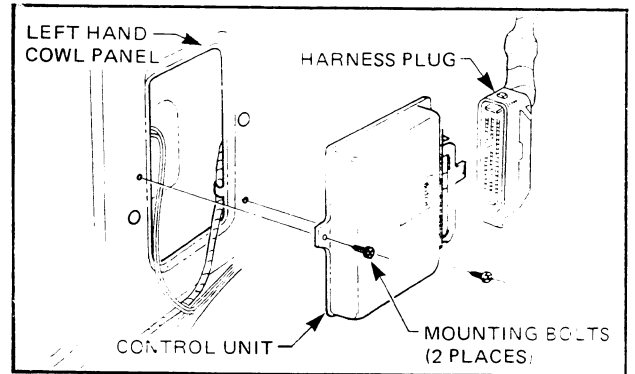

Figure 6C-98

4. Disconnect the wiring harness plug from the control unit by pulling up tang and swing harness out from control unit. Refer Fig. 6C-98A.

REINSTALL

Installation is reversal of removal.

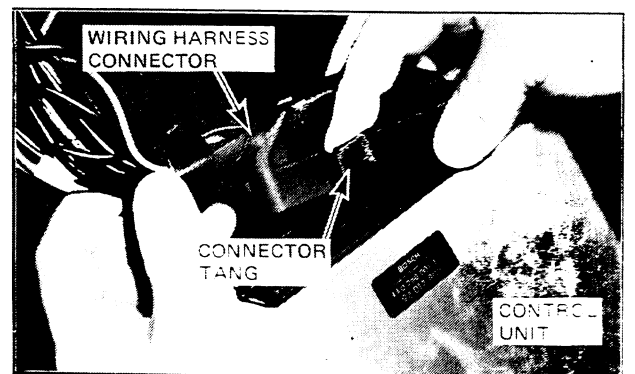

Figure 6C-98A

3.21 THROTTLE POSITION SWITCH

REMOVE

1. Disconnect battery earth lead.
2. Disconnect wiring harness plug from throttle position switch.
3. Remove vacuum fitting from manifold next to throttle position switch.
4. Remove 2 mounting screws and withdraw switch from throttle shaft. Refer Fig. 6C-99.

REINSTALL

Installation is reverse of removal, however the following should be noted.

Ensure that the flat section of throttle shaft slides into the correct position inside the throttle switch. Refit vacuum fitting into manifold and check that the automatic transmission modulator pipe is fitted securely into the vacuum fitting.

Do not tighten mounting screws as switch must be adjusted.

ADJUSTMENT

1. The throttle position switch is to be positioned so that the closed throttle contacts open with the slightest throttle opening. If the position of the switch is correct, a 'click' from within the switch is heard on opening the throttle.

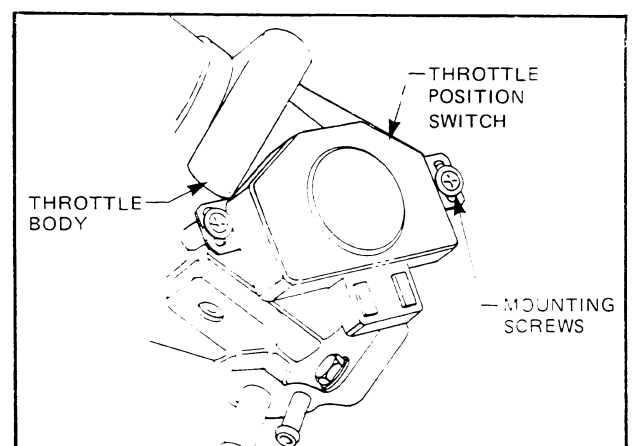

Figure 6C-99

6C-44 ENGINE FUEL

2. If there is no 'click', rotate the switch slightly and then operate the throttle, continue adjusting the switch until the correct position is found. Refer Fig. 6C-99A.
3. Check that the switch is not preventing the throttle butterfly from returning to its stop and tighten mounting screws.

NOTE: The high load switching contacts are non adjustable and are automatically set when the closed throttle adjustment is made.

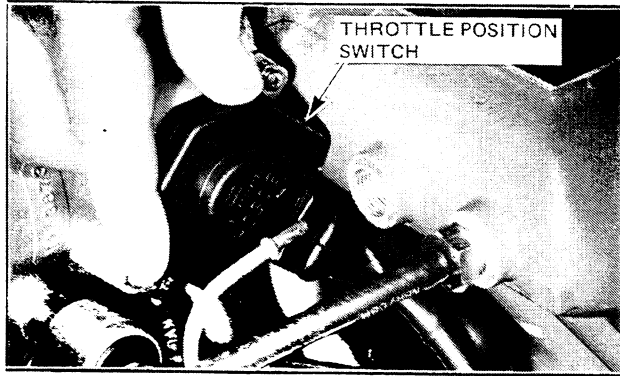

Figure 6C-99A

3.22 COOLANT TEMPERATURE SENSOR REPLACE

1. Disconnect battery earth lead.
2. Remove wiring harness connector from coolant temperature sensor. Refer Fig. 6C-100.
3. Drain coolant from engine to below sensor level.
4. Remove sensor from cylinder head.
5. Apply GMH sealant P/N 3835214, to sensor threads, refit into cylinder head.
6. Refit harness connector.
7. Add coolant to radiator and check for leaks.

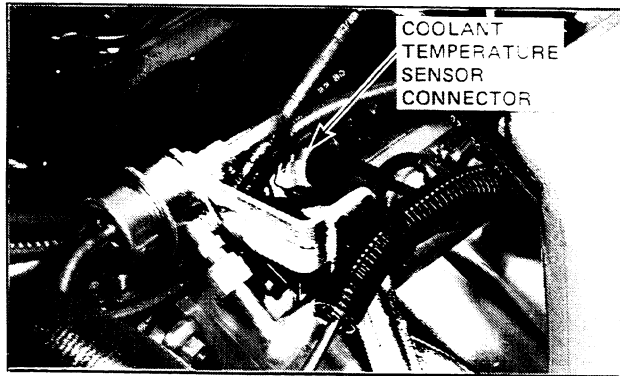

Figure 6C-100

ON ENGINE TEST

The temperature and resistance reading should be made before and after engine warm up.

Engine Cold

1. Disconnect battery earth lead.
2. Disconnect wiring harness connector from temperature sensor.
3. Remove radiator cap, place a thermometer in the radiator coolant and read coolant temperature.

4. Using an ohmmeter, measure the resistance across the terminals of the temperature sensor. Refer Fig. 6C-101.
5. Connect wiring harness connector and battery earth lead.
6. Warm up engine sufficiently and then follow steps 1 thru 4. Check results with the following chart. If results indicate suspect temperature sensor, perform the more accurate test below.

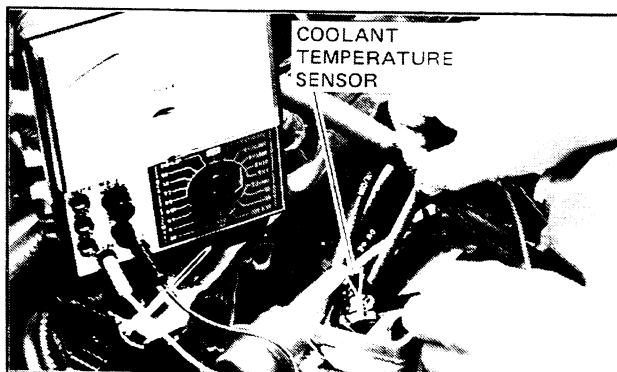

Figure 6C-101

OFF ENGINE TEST

Remove sensor as per steps 1 thru 4 for replacement. With the temperature sensor suspended in a beaker of 50/50 glycol/water, record resistance across the terminals at various temperatures. Refer Fig. 6C-102. Check the results with the following chart.

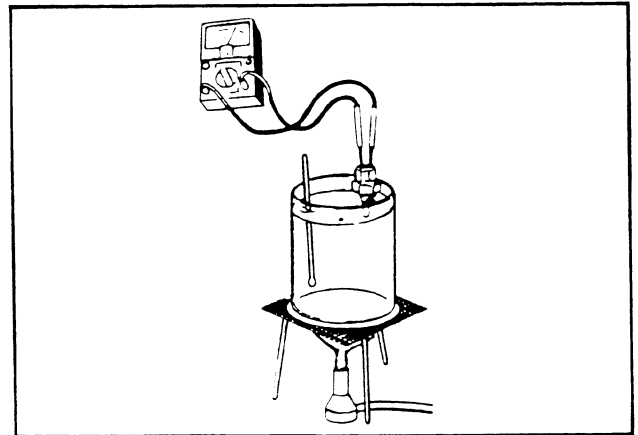

Figure 6C-102

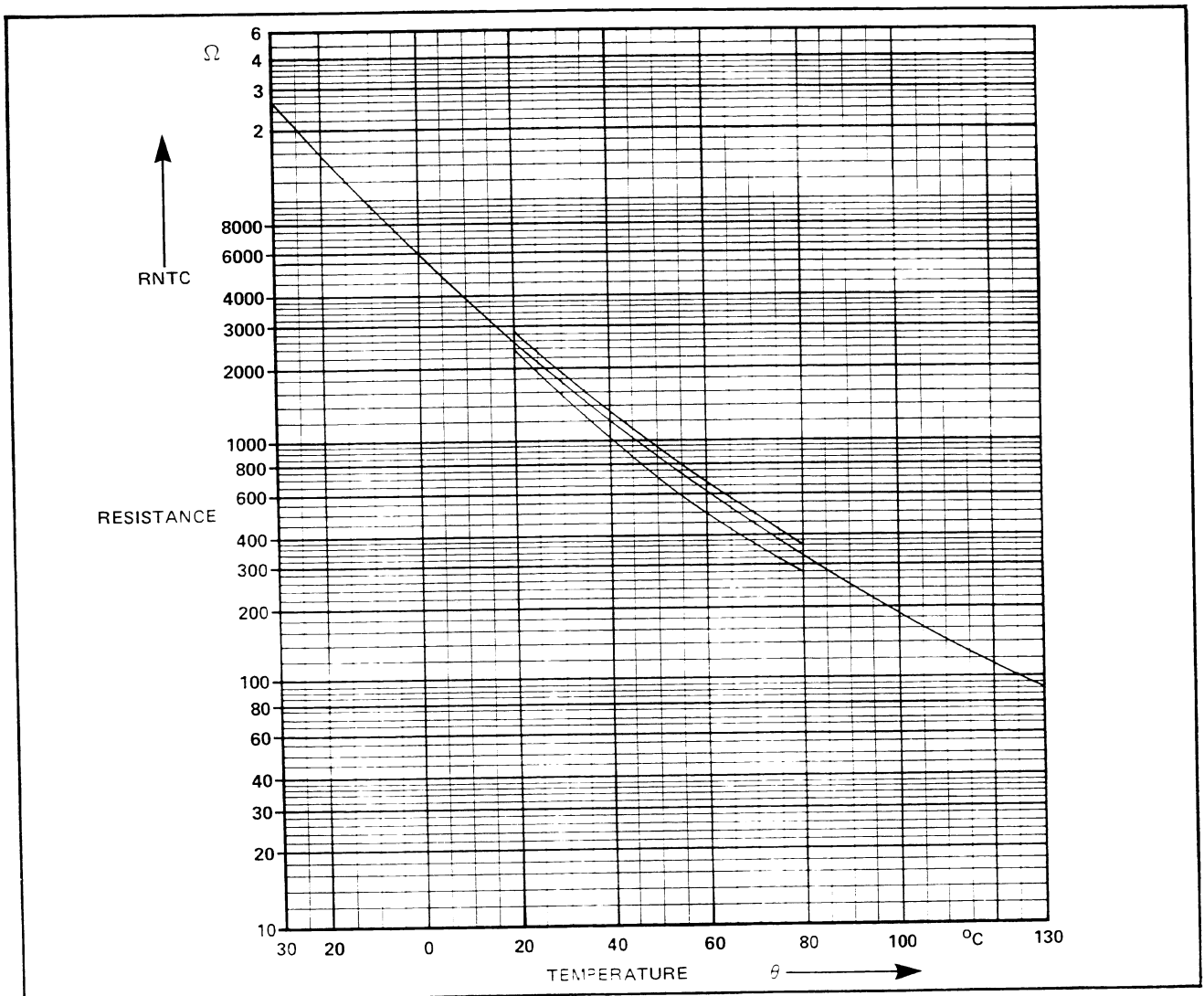

Figure 6C-103

If, in either test, the resistance of the sensor with respect to coolant temperature is not as specified in the above graph the sensor is faulty.

6C-46 ENGINE FUEL

3.23 CONTROL RELAY

REMOVE

1. Remove fuse box cover. Fig. 6C-104.

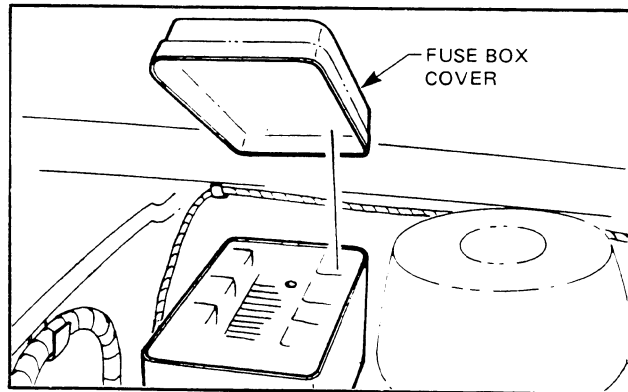

Figure 6C-104

2. Pull out relay from its position. Refer Fig. 6C-105.

REINSTALL

Installation is reversal of removal.

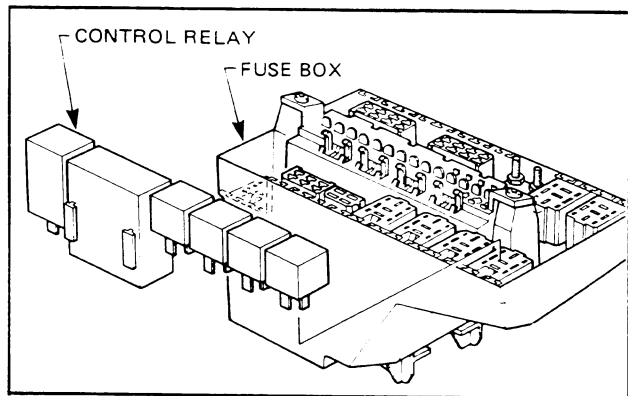

Figure 6C-105

4. DIAGNOSIS

4.1 CIRCUIT TESTING PROCEDURE

ELECTRONIC FUEL INJECTION TEST EQUIPMENT

A set of special equipment has been developed for diagnosing and testing the EFI system of VK Series vehicles.

The set consists of an ignition diagnostic system (part no. SD28013) and a companion electronic fuel injection accessory kit (part no. SD28014). Part Nos. SD28013 and SD28014 are marketed only as a set and are not available separately. The EFI accessory kit includes a fuel pressure gauge.

The ignition diagnostic system on its own, serves as an effective ignition tester. The ignition diagnostic system and the EFI accessory kit must be used together when testing the EFI system.

Operating instructions for the ignition system tests and the EFI system tests are included as part of the test equipment package.

Details on availability of the test equipment are obtainable from:

General Motors- Holden's Sales Pty. Ltd.
Service Division,
Box 548D, GPO,
Melbourne 3001.
Australia.

Should the recommended EFI test equipment not be available, the following material may be used for checking the Fuel Injection System.

1. 12-volt, **2 watt** test lamp with standard test probes.
2. Ohmmeter, measurement range 0 to 5000 ohms.
3. Tachometer.

The cable harness plug must be separated from the control unit in order to test the cable harness and the engine sensors.

Since the contact terminals on the plug strip are not marked, the contacts must be counted for the various tests.

Terminals 1 through 13 are located on the long terminal strip; terminal 1 is next to the cable entrance. Refer Fig. 6C-105A.

Terminals 14 through 25 are on the shorter terminal strip. Refer Fig. 6C-105A.

Terminal 14 is next to the cable entrance.

Some tests involve cranking the engine, therefore appropriate safety precautions must be observed.

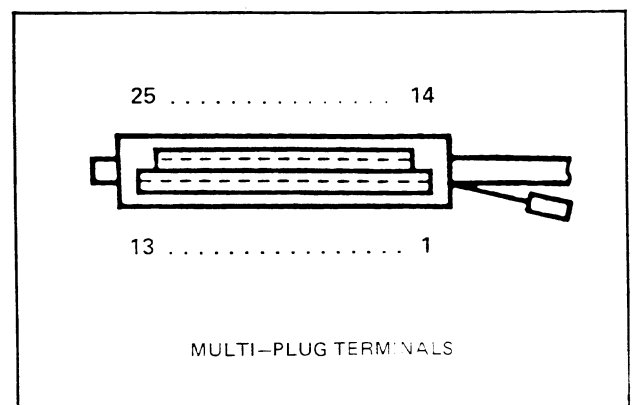
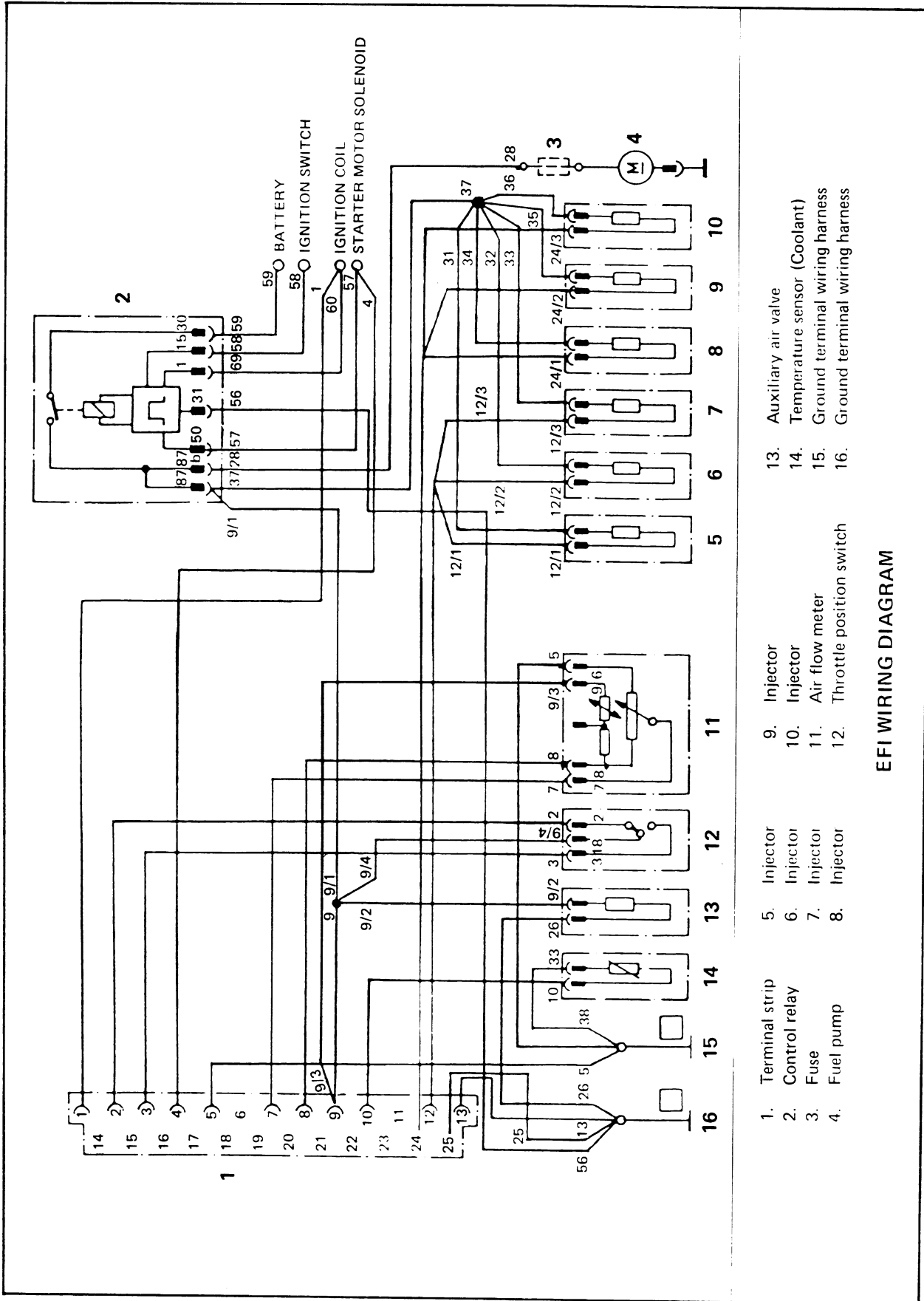

Figure 6C-105A

6C-48 ENGINE FUEL



EFI WIRING DIAGRAM

Figure 6C-106

ENGINE FUEL 6C-49

Function or Component to be Tested	Test With	Measure Between Terminals	Test Status	Indication (correct)	If Defective	Notes
Fuel pump operating	Test lamp	+ and - on fuel pump	Ignition in crank position	Test lamp lights. If pump runs, it can be heard.	Look for break in cable harness or blown fuse or faulty relay.	If pump runs but engine will not run check fuel pressure and volume pumped as per service operation 3.13.
Relay closing	Can be heard or test lamp	Listen to relay. 87 and earth	Ignition in crank position	Relay clicks when activated. Lamp lights	Check current supply wires to relay.	Refer Fig. 6C-107
Battery supply to relay	Test lamp	30 and 31	Relay removed	Lamp lights	Break in supply or earth leads to relay.	Check fusible link.
Ignition switch signal	Test lamp	15 & earth	Ignition on	Lamp lights	Break in ignition switch wiring.	
Crank signal	Test lamp	50 & earth	Ignition in crank position	Lamp lights	Break in current supply in starter solenoid circuit.	
Ignition pulse signal	Test lamp	1 & earth	Engine cranking	Lamp flickers as engine turns	Break in lead from - coil terminal or faulty ignition system	Refer Fig. 6C-108
Injector valves and wiring	Ohmmeter	Cyl.1 thru 3 Term.12 & 9 Cyl.4 thru 6 Term.24 & 9	Ignition off Disconnect wiring harness plugs at air flow meter & aux. air valve & throttle position switch.	Approximately 3 to 4 ohms	Check for break in cable harness. Check injectors individually with ohmmeter. value 16 ohms.	Refer Fig. 6C-109 Refer Fig. 6C-110
	Test lamp (2 watts)	Cyl.1 thru 3 Term.12 & 13 Cyl.4 thru 6 Term.24 & 25	Ignition on & in crank position	Lamp lights	Check for break in cable harness. Injector valve defective. Short to earth in wires 12 and 13.	
Injection pulse signal from control unit	Test lamp (2 watts)	Remove plug from injector and measure across terms. on plug	Ignition in crank position	Lamp flickers brightly initially and dims within 10 seconds	Check wiring for supply signals at control unit connector. If control unit is considered faulty test its operation on another vehicle.	Never allow terminals on injector leads to short.
Supply voltage to control unit	Test lamp	9 & earth	Ignition on and in crank position	Lamp lights	Relay defective. Check for break in wiring from No.9 terminal. Check for break in wiring from battery supply, fusible link blown.	

6C-50 ENGINE FUEL

Function or Component to be Tested	Test With	Measure Between Terminals	Test Status	Indication (correct)	If Defective	Notes
Control unit and system earth	Test lamp	9 and 5 9 and 13 9 and 25	Ignition on and in crank position	Lamp lights	Check for break in leads 5, 13 & 25.	
Initiation of injection impulse	Test lamp	9 and 1	Operate starter briefly	Lamp flickers	Check for break in wiring – ignition coil terminal to No. 1 connector term. Faulty injection system.	Refer Fig. 6C-111
Start signal from starter for control unit	Test lamp	4 and 5	Operate starter briefly	Lamp lights	Check for break in wiring between starter & terminal 50 on relay. Break in wire from connector term. 4 to starter.	Test lamp will light only in crank mode. If lamp lights with ignition on, check why term. 50 has power. Refer Fig.6C-112
Operation of idle contacts in throttle valve switch	Ohmmeter	2 and 9	Ignition off Accelerator pedal in idle position Accelerator pedal slightly depressed	0 ohms approx. ∞ ohms	Check for break in cable harness or replace throttle position switch.	Refer Fig.6C-113
Operation of full load contacts in throttle valve body	Ohmmeter	3 and 9	Ignition off Accelerator pedal in idle position Accelerator pedal fully depressed	∞ ohms 0 ohms approx.	Check for break in cable harness, or replace throttle position switch.	Refer Fig. 6C-114
Coolant temperature sensor	Ohmmeter	10 and 5	Ignition off	Temperature dependent 0°C– 5500 ohms 20°C– 2450 ohms 80°C– 320 ohms 97°C– 200 ohms	Break in cable harness or replace temperature sensor	Refer Fig. 6C-115
Air flow meter	Ohmmeter	7 and 5	Ignition off Push air flow meter flap slowly open	If the resistance is at any value other than 0 or infinity the air flow meter is OK.	Break and or short circuit in cable harness. Air flow meter sensor defective.	Refer Fig. 6C-116
Auxiliary air valve circuit	Test lamp	Remove plug from aux. air valve measure across plug terminals	Ignition on in crank position	Lamp lights	Check for breaks in auxiliary air valve earth and voltage supply wiring.	
Auxiliary air valve	Ohmmeter	Remove plug from aux. air valve measure across terms. of valve	Ignition off	35 – 40	Replace.	

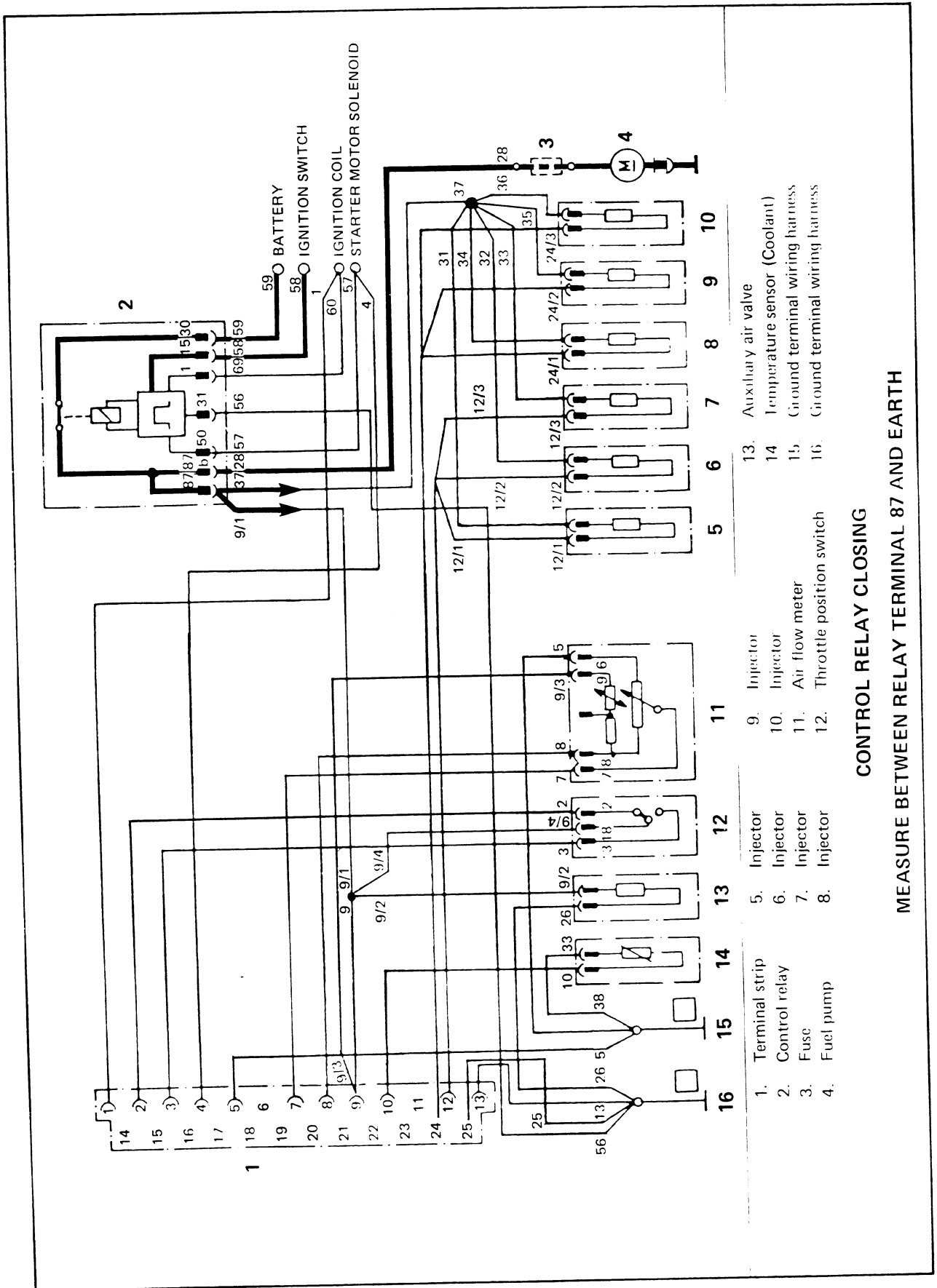

**CONTROL RELAY CLOSING
MEASURE BETWEEN RELAY TERMINAL 87 AND EARTH**

- | | | | |
|-------------------|-------------|------------------------------|------------------------------------|
| 1. Terminal strip | 5. Injector | 9. Injector | 13. Auxiliary air valve |
| 2. Control relay | 6. Injector | 10. Injector | 14. Temperature sensor (Coolant) |
| 3. Fuse | 7. Injector | 11. Air flow meter | 15. Ground terminal wiring harness |
| 4. Fuel pump | 8. Injector | 12. Throttle position switch | 16. Ground terminal wiring harness |

Figure 6C-107

6C-52 ENGINE FUEL

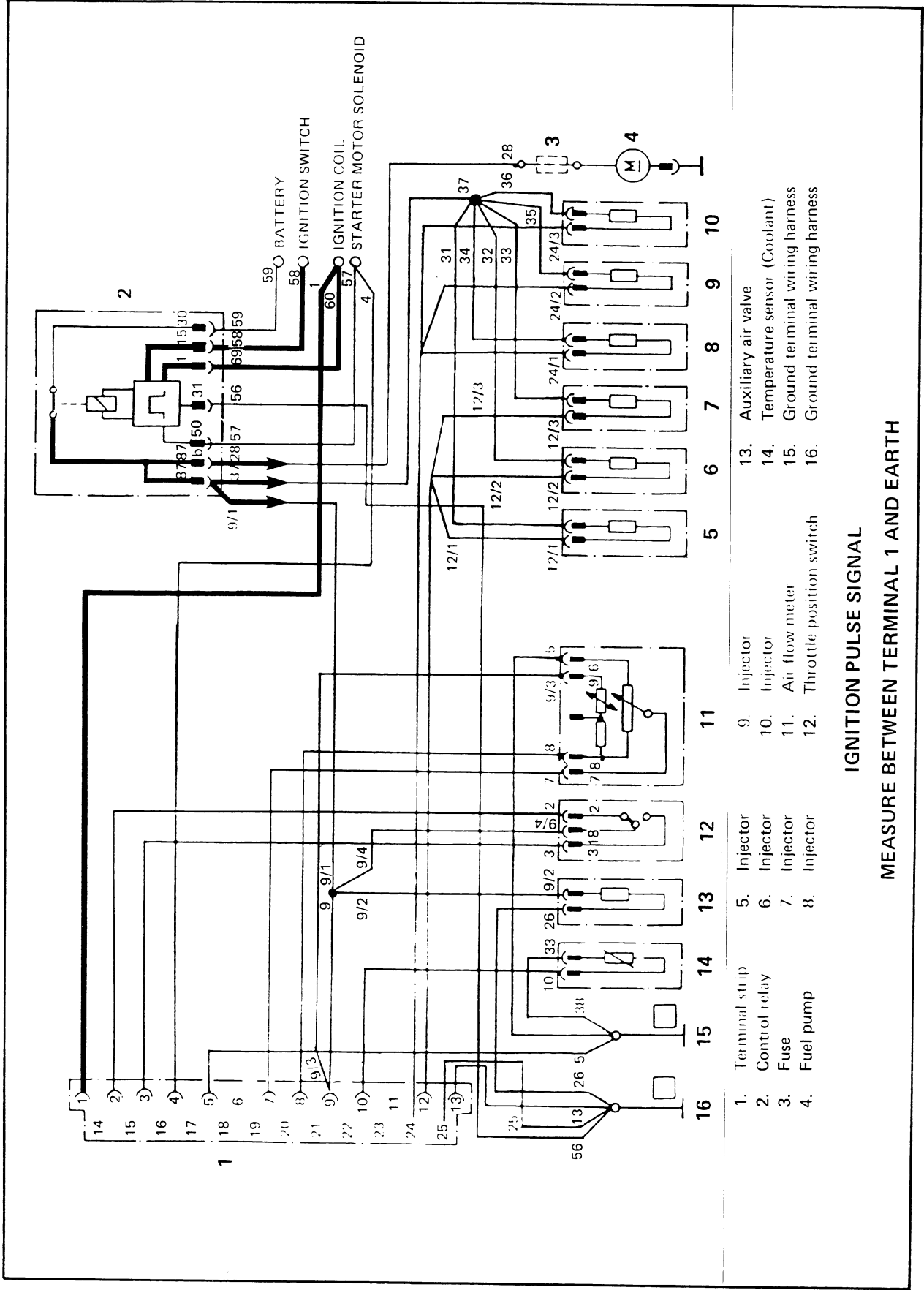
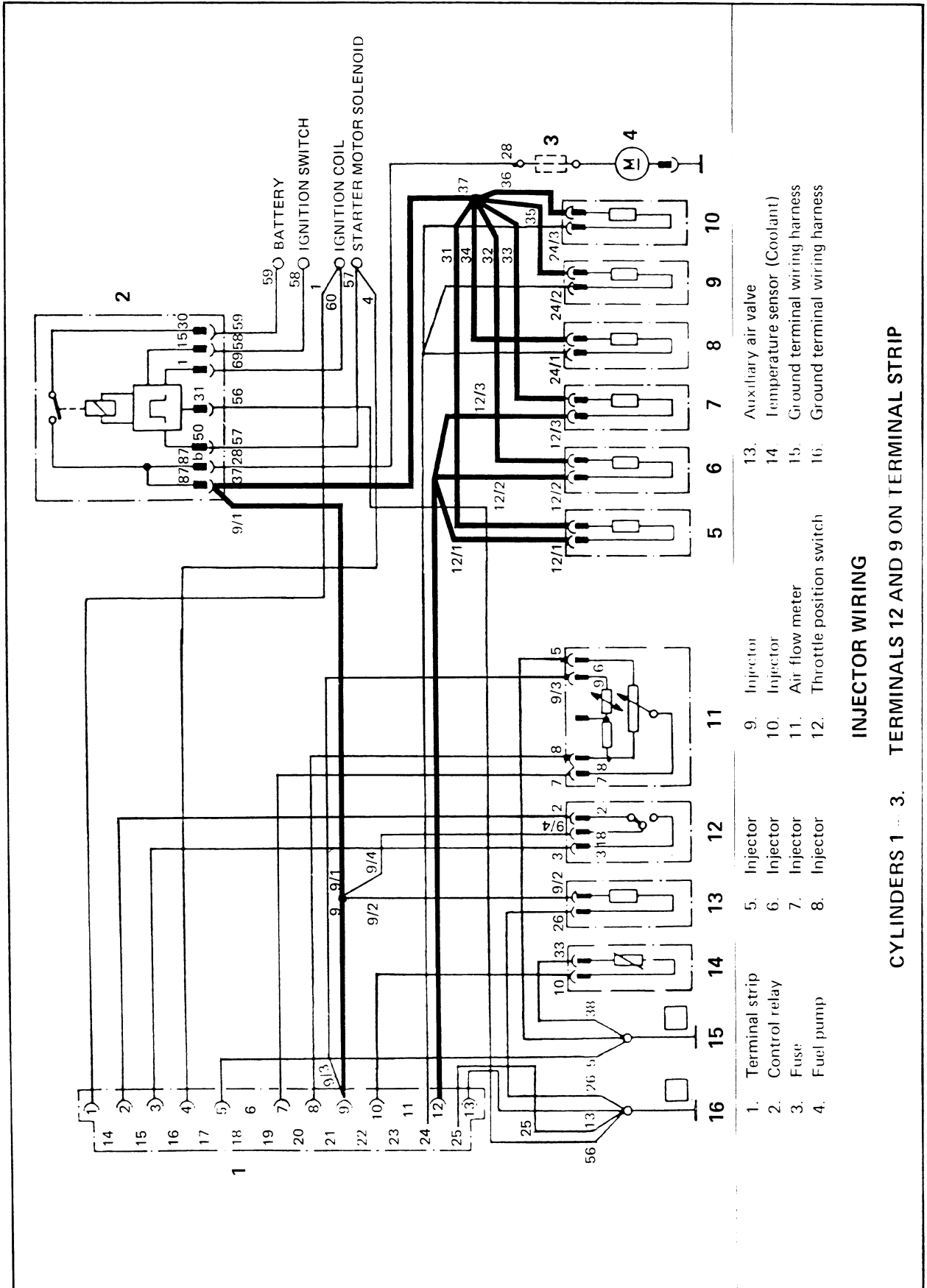

Figure 6C-108



INJECTOR WIRING

CYLINDERS 1 - 3. TERMINALS 12 AND 9 ON TERMINAL STRIP

- 1. Terminal strip
- 2. Control relay
- 3. Fuse
- 4. Fuel pump
- 5. Injector
- 6. Injector
- 7. Injector
- 8. Injector
- 9. Injector
- 10. Injector
- 11. Air flow meter
- 12. Throttle position switch
- 13. Auxiliary air valve
- 14. Temperature sensor (Coolant)
- 15. Ground terminal wiring harness
- 16. Ground terminal wiring harness

Figure 6C-109

6C-54 ENGINE FUEL

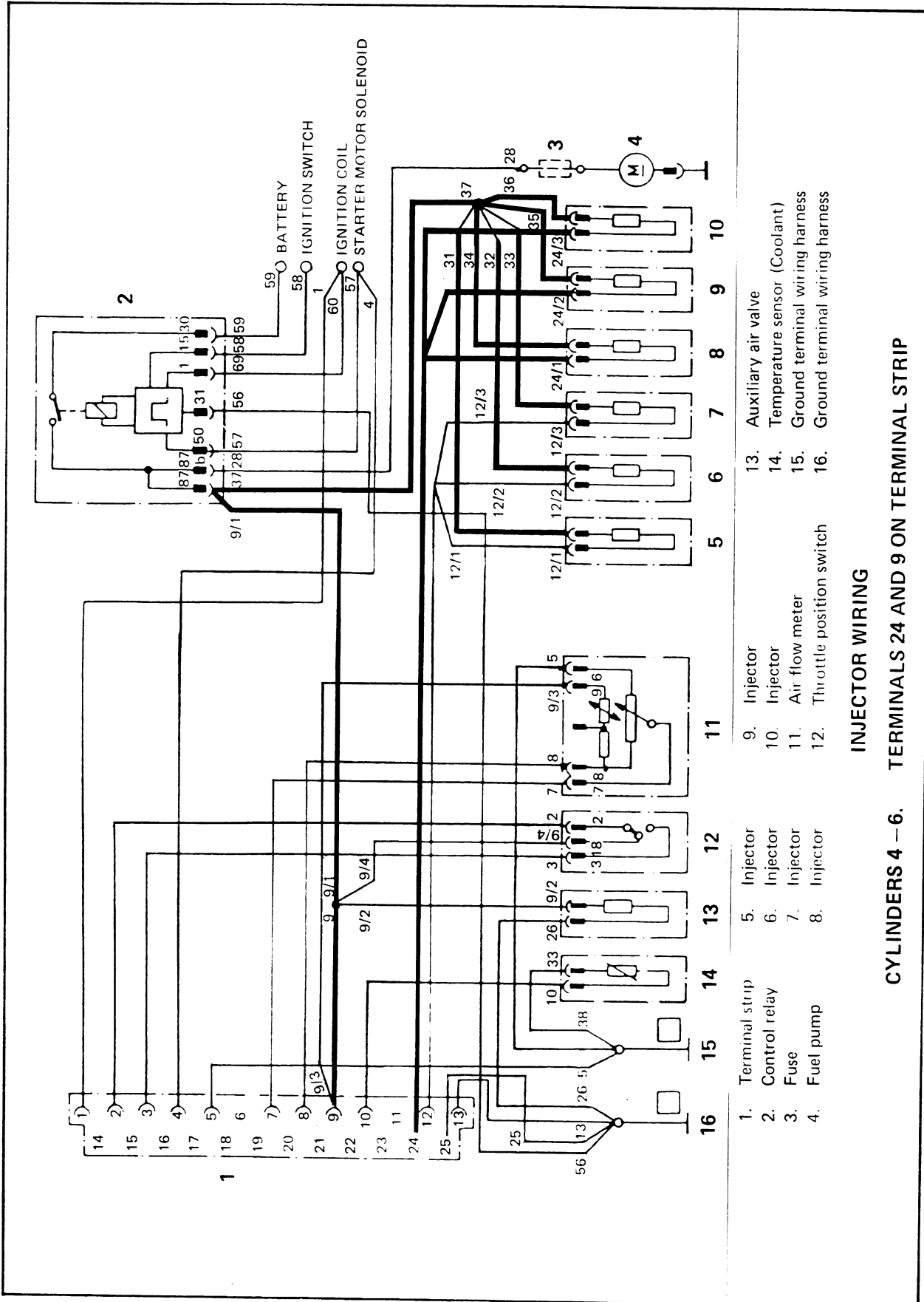

- | | | | |
|-------------------|-------------|------------------------------|------------------------------------|
| 1. Terminal strip | 5. Injector | 9. Injector | 13. Auxiliary air valve |
| 2. Control relay | 6. Injector | 10. Injector | 14. Temperature sensor (Coolant) |
| 3. Fuse | 7. Injector | 11. Air flow meter | 15. Ground terminal wiring harness |
| 4. Fuel pump | 8. Injector | 12. Throttle position switch | 16. Ground terminal wiring harness |

INJECTOR WIRING

CYLINDERS 4 - 6. TERMINALS 24 AND 9 ON TERMINAL STRIP

Figure 6C-110

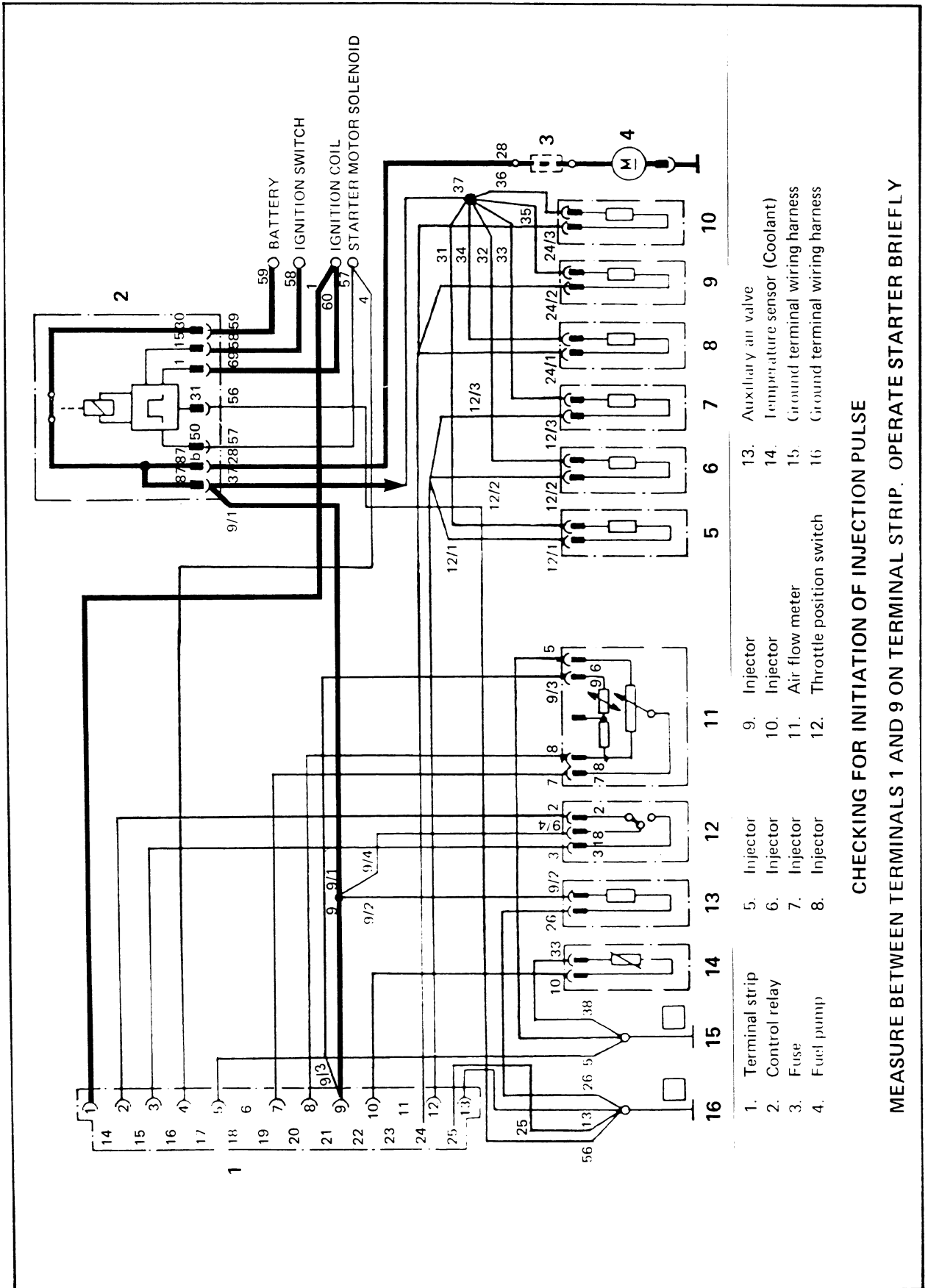

CHECKING FOR INITIATION OF INJECTION PULSE

MEASURE BETWEEN TERMINALS 1 AND 9 ON TERMINAL STRIP. OPERATE STARTER BRIEFLY

Figure 6C-111

6C-56 ENGINE FUEL

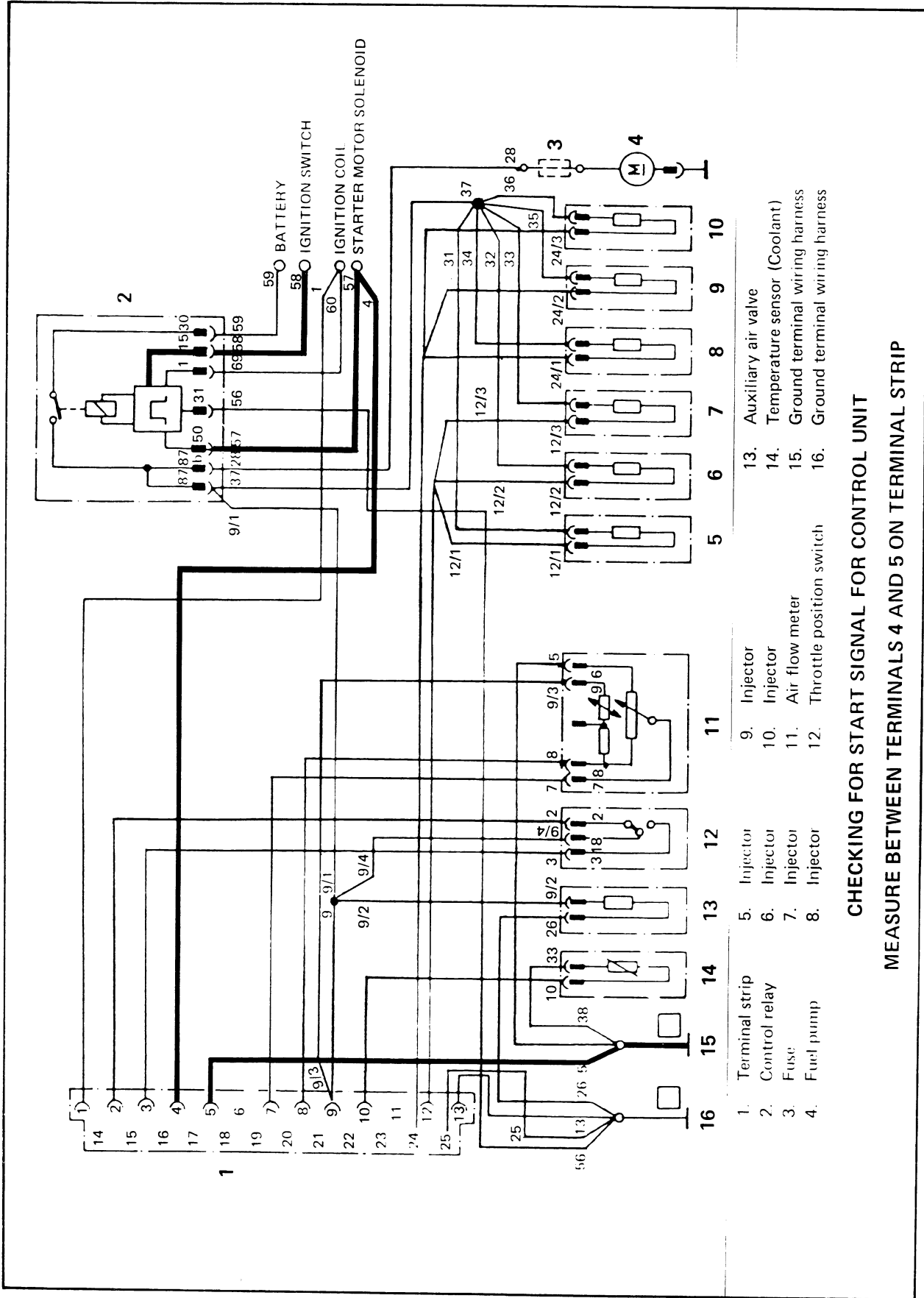

CHECKING FOR START SIGNAL FOR CONTROL UNIT

MEASURE BETWEEN TERMINALS 4 AND 5 ON TERMINAL STRIP

Figure 6C-112

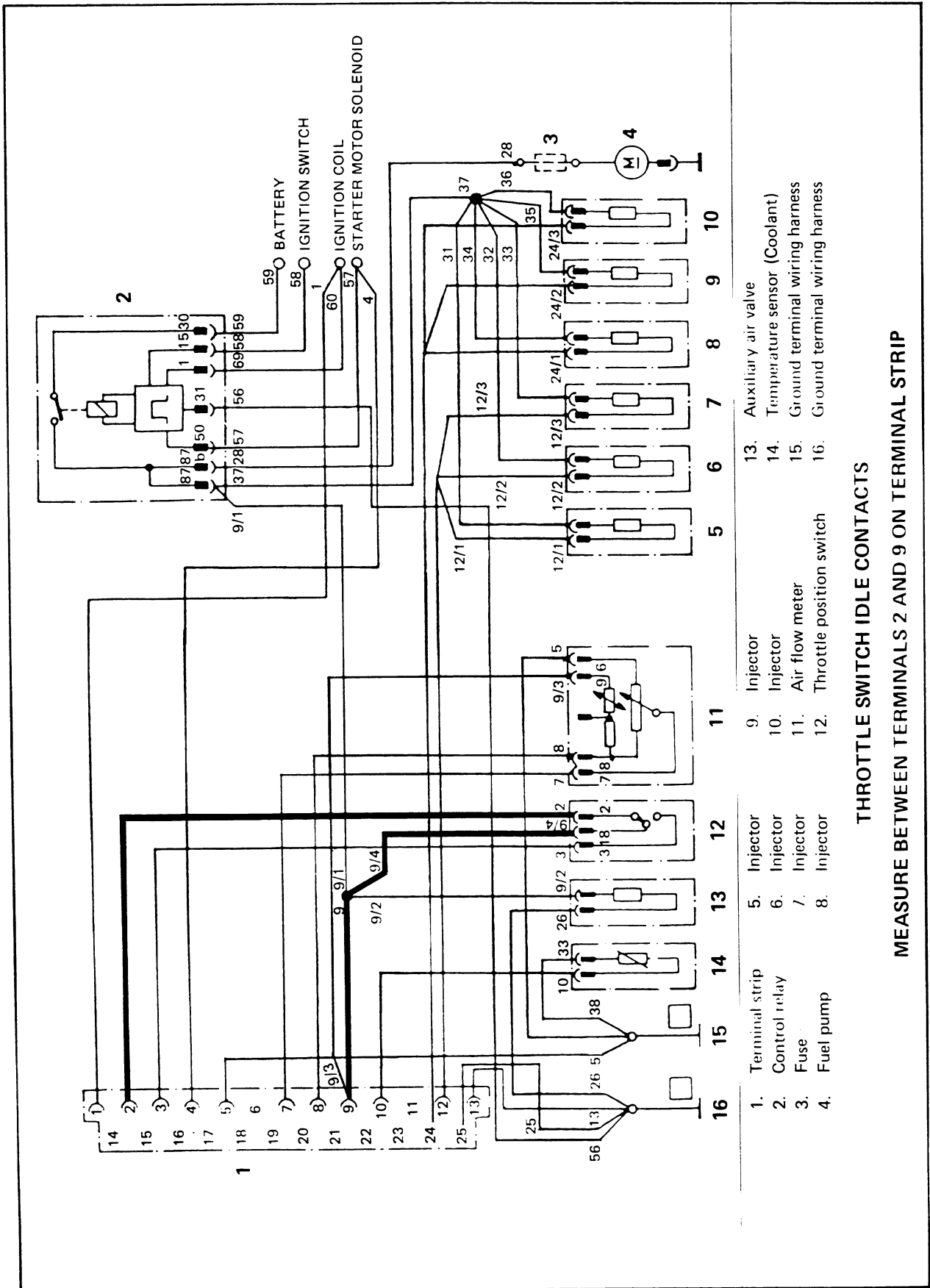

THROTTLE SWITCH IDLE CONTACTS
MEASURE BETWEEN TERMINALS 2 AND 9 ON TERMINAL STRIP

Figure 6C-113

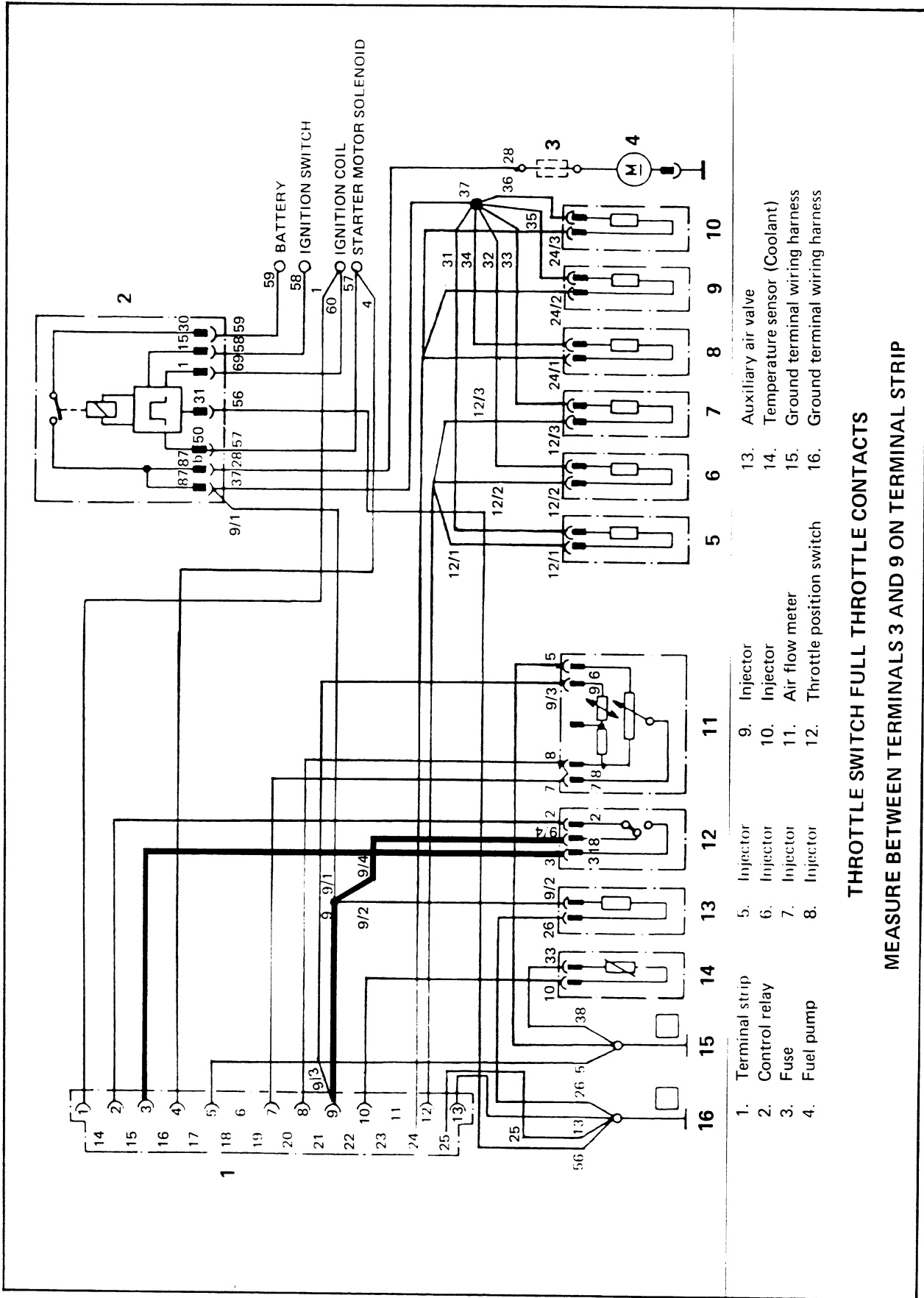

THROTTLE SWITCH FULL THROTTLE CONTACTS
MEASURE BETWEEN TERMINALS 3 AND 9 ON TERMINAL STRIP

Figure 6C-114

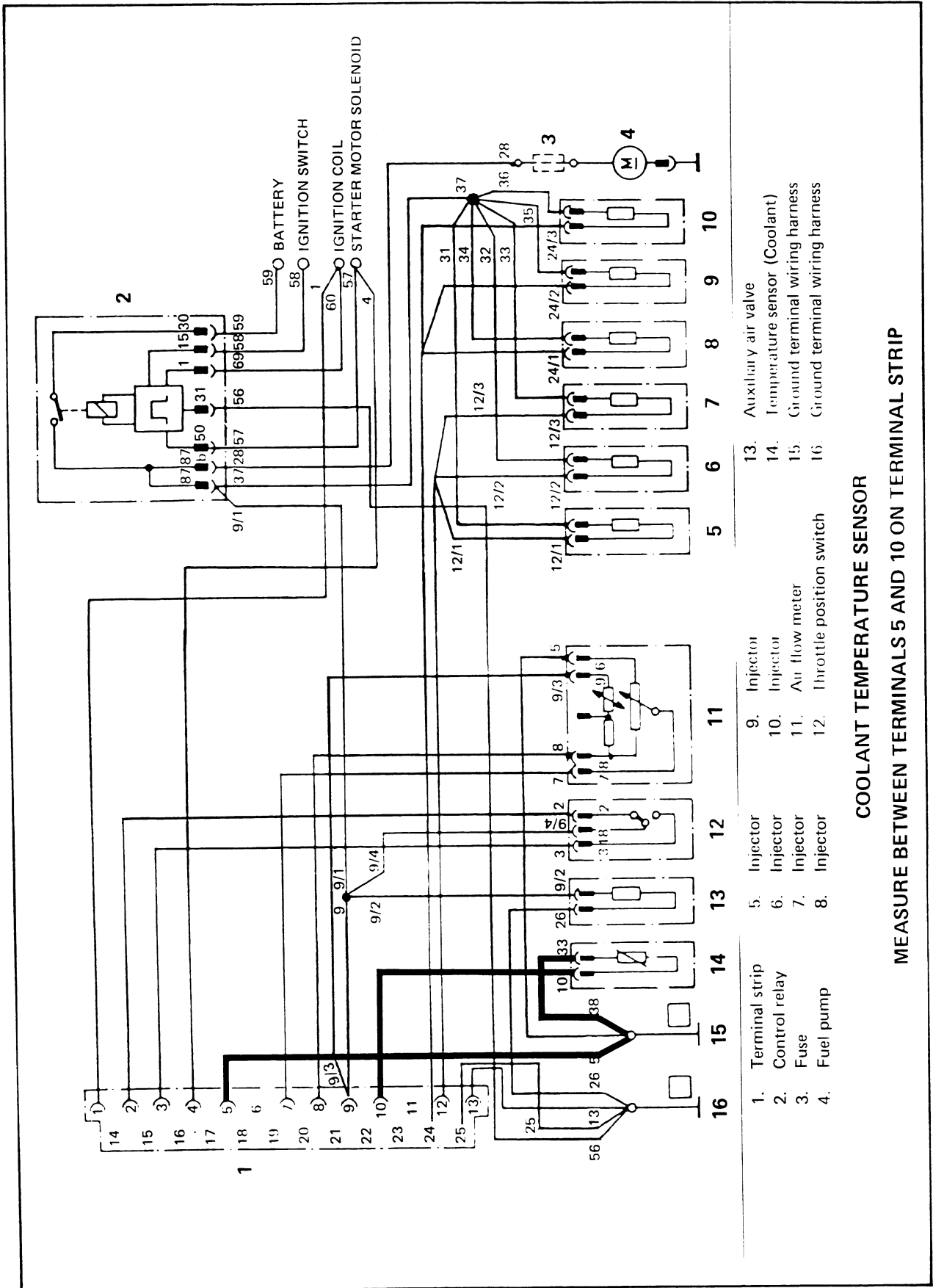

- | | | | | | | | |
|----|----------------|----|----------|-----|--------------------------|-----|--------------------------------|
| 1. | Terminal strip | 5. | Injector | 9. | Injector | 13. | Auxiliary air valve |
| 2. | Control relay | 6. | Injector | 10. | Injector | 14. | Temperature sensor (Coolant) |
| 3. | Fuse | 7. | Injector | 11. | Air flow meter | 15. | Ground terminal wiring harness |
| 4. | Fuel pump | 8. | Injector | 12. | Throttle position switch | 16. | Ground terminal wiring harness |

COOLANT TEMPERATURE SENSOR

MEASURE BETWEEN TERMINALS 5 AND 10 ON TERMINAL STRIP

Figure 6C-115

6C-60 ENGINE FUEL

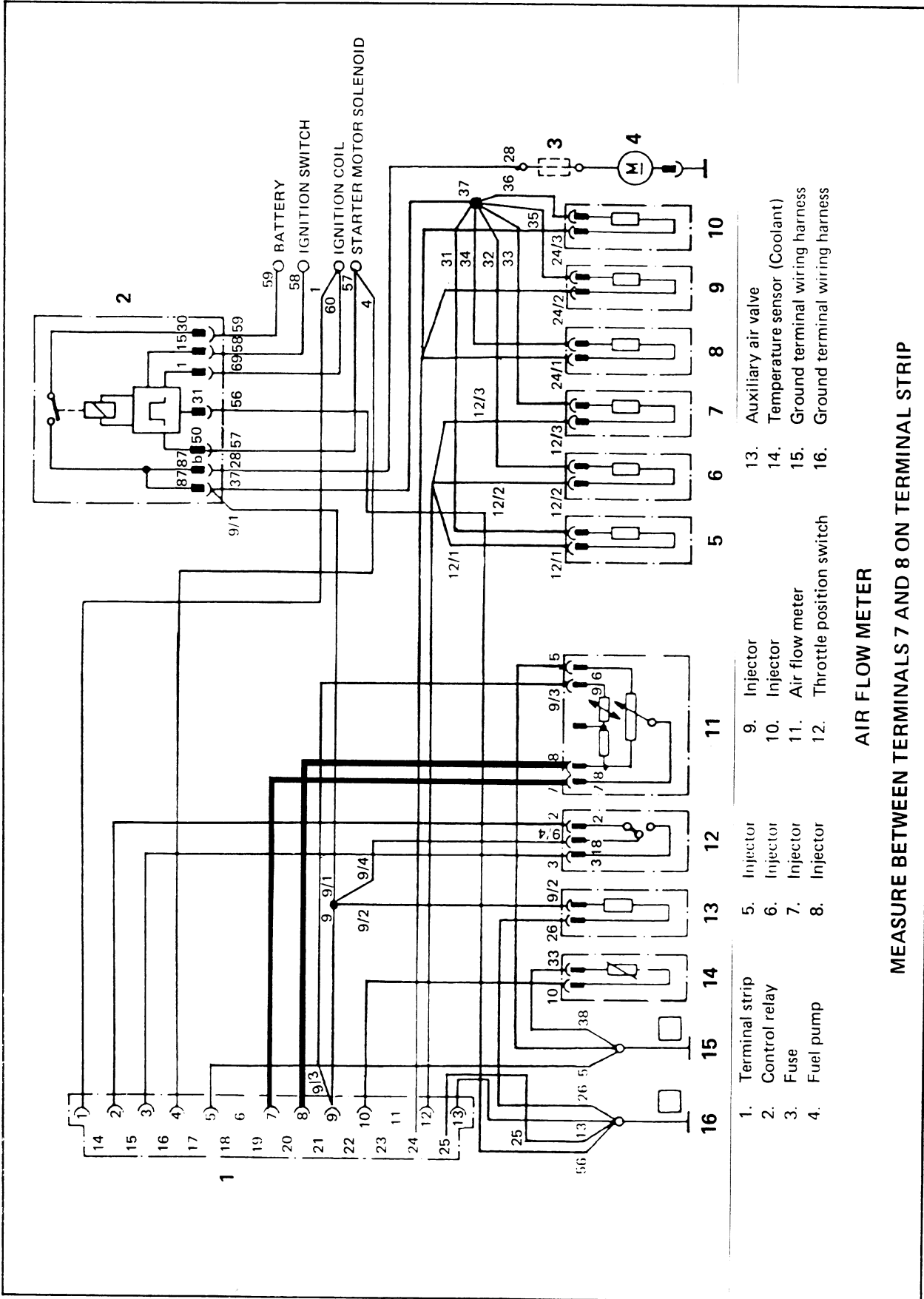

AIR FLOW METER

MEASURE BETWEEN TERMINALS 7 AND 8 ON TERMINAL STRIP

- | | | | |
|-------------------|-------------|------------------------------|------------------------------------|
| 1. Terminal strip | 5. Injector | 9. Injector | 13. Auxiliary air valve |
| 2. Control relay | 6. Injector | 10. Injector | 14. Temperature sensor (Coolant) |
| 3. Fuse | 7. Injector | 11. Air flow meter | 15. Ground terminal wiring harness |
| 4. Fuel pump | 8. Injector | 12. Throttle position switch | 16. Ground terminal wiring harness |

Figure 6C-116

4.2 TROUBLE DIAGNOSIS

The LE-2 Fuel Injection System can be checked with the following. If any abnormality is found in any component, refer to the testing procedures in the 'Circuit Testing Procedure' or 'Service Operations' in this Supplement.

Before attempting any test, check the following items.

1. Check all wiring harness connections to all components, particularly the 25 pin connector on the control unit, the air flow meter connector and coolant temperature sensor connector.

2. Make sure the ignition and starting systems are in good order.
3. The LE-2 system accurately meters the inlet air flow so any air leak can cause an improper air-fuel ratio, resulting in faulty engine operation.

NOTE: When connecting or disconnecting harness connections, ensure that the ignition switch is 'OFF' and the negative battery terminal is disconnected. Failure to do so will damage the control unit.

Engine Condition	Possible Cause	Checks
Engine will not start	Faulty ignition system. Faulty fuel pump operation. Improper ignition signal input. Problem in the following circuits: — Coolant temperature sensor. — Air flow sensor. — Fuel injectors. — Control unit. No fuel — tank empty.	Disconnect high tension lead from one spark plug and check for spark. Check electrical connections. Remove starter motor solenoid wire and turn ignition to "START," pump action should be heard. Check fuel pressure and volume pumped. Check ignition signal input. Check the operation of relay. Check each circuit.
Engine flooded, spark plugs wet.	Open coolant temperature sensor circuit EFI system. Goes fully rich.	Check circuit and connections. Replace faulty sensor if proved defective.
Engine starts, then stalls	Faulty ignition signal input. Fuel pump not functioning correctly. Faulty coolant temperature or air flow sensor circuits. Malfunctioning auxiliary air valve.	Check ignition signal input. Check electrical connections at fuel pump. Check operation of control relay. Check fuel pump pressure and volume pumped. Check circuits and component operation. Start engine (cold), pinch the hose which leads from the air valve to behind the throttle body. Results: <ol style="list-style-type: none"> a. If idle speed drops, perform circuit test. b. If idle speed remains high or unstable, perform the following checks: Check for manifold vacuum leaks, if no problem is found, perform the following circuit tests: <ul style="list-style-type: none"> — Throttle position switch (idle contact and full load contact). — Control unit ground circuit. — Air flow meter potentiometer. — Air regulator and fuel pump circuit. — Air regulator circuit. — Control unit power input circuit. — Injector circuit.

6C-62 ENGINE FUEL

Engine Condition	Possible Cause	Checks
Engine Misfires	<p>Faulty ignition system. Fuel blockage.</p> <p>Water in fuel. Low fuel pressure. Loose Harness connectors.</p> <p>Improper control relay operation. Faulty EFI circuit. Defective injector valves. Malfunctioning control unit.</p>	<p>Check ignition system.</p> <p>Check fuel line for blockages in: Tank filter Fuel filter Fuel pipes Fuel injectors</p> <p>Drain tank and lines.</p> <p>Perform fuel pressure test.</p> <p>Check all connectors for looseness or corrosion, including earth circuits.</p> <p>Check control relay operation.</p> <p>Perform circuit test.</p> <p>Check injectors operation.</p> <p>Try another control unit.</p>
Engine lacks power	<p>Faulty ignition system. Malfunctioning in throttle valve body.</p> <p>Malfunction in air flow meter.</p> <p>Fuel blockage.</p> <p>Blocked air filter. Poor engine condition. Check circuits in throttle position switch. Low fuel pressure. Problem in the following circuits: <ul style="list-style-type: none"> – Air and coolant temperature sensors. – Fuel pump. – Air flow meter. – Throttle position switch contacts. – Ignition coil to control relay. – Control unit power input circuit. – Injector circuit. </p>	<p>Check ignition system.</p> <p>Make sure throttle butterfly is opening fully and not jamming.</p> <p>Check air flow flap movement. Check that it opens smoothly and fully.</p> <p>Check fuel line for blockages in: Tank filter Fuel filter Fuel pipes Fuel injectors</p> <p>Check element condition.</p> <p>Check engine compressions.</p> <p>Check switch operation and wiring.</p> <p>Perform fuel pressure test.</p> <p>Check each circuit. Perform component checks where necessary.</p>
Engine surge	<p>Malfunctioning air flow meter. Intake air leakage at the following points: <ul style="list-style-type: none"> – Manifold gaskets. – Air flow meter hoses. <p>Improper fuel pressure. No vacuum advance.</p> <p>Faulty EGR system.</p> <p>Problem in the following circuits: <ul style="list-style-type: none"> – Throttle position switch, idle contact and full load contact. – Air flow meter. – Control unit circuit. – Air temperature sensor. – Coolant temperature sensor. – Auxiliary air valve circuit. – Ignition coil to control relay. – Control unit power input circuit. – Injector circuit. </p> </p>	<p>Check air flow meter mechanical movement.</p> <p>Using a finger, check flap movement for smooth operation. Check for intake air leaks.</p> <p>Perform fuel pressure test.</p> <p>Check for correct vacuum hose connections ignition distributor operation.</p> <p>Check EGR operation.</p> <p>Check each circuit. Then proceed to component checks.</p>

ENGINE FUEL 6C-63

Engine Condition	Possible Cause	Checks
Flat spot on acceleration	<p>Improper ignition system.</p> <p>Malfunctioning air flow meter.</p> <p>Intake air leakage at following points:</p> <ul style="list-style-type: none"> – Manifold gaskets. – Air flow meter hoses. <p>Improper fuel pressure.</p> <p>Improper EFI circuit.</p> <p>EGR system.</p>	<p>Check ignition system and vacuum advance signal.</p> <p>Check air flow meter mechanical movement. Using a finger, check for smooth flap movement.</p> <p>Check for intake air leaks.</p> <p>Perform fuel pressure test.</p> <p>Perform complete circuit test, then perform components check.</p> <p>Incorrect vacuum hose connections. Check EGR operation.</p>
Excessive petrol consumption CO reading high	<p>Improper ignition timing or ignition system.</p> <p>Improper air cleaner filter.</p> <p>Improper fuel pressure.</p> <p>Problem in the following circuits:</p> <ul style="list-style-type: none"> – Coolant temperature sensor. – Air temperature sensor. – Throttle position switch, idle contact and full load contact. – Air flow meter. – Auxiliary air valve. – Fuel pump circuit. – Injector circuits. <p>Control unit defective.</p>	<p>Check ignition timing and vacuum advance signal.</p> <p>Check ignition system for hot spark.</p> <p>Check air cleaner filter and replace if necessary.</p> <p>Perform fuel pressure test.</p> <p>Check each circuit, then proceed to component check.</p> <p>Check operation of control unit, with a known good unit.</p>
Difficult to start after standing hot	<p>Fuel system not holding pressure allowing fuel to boil in injectors when engine stopped.</p>	<p>Fuel pressure stays at 250 ± 20 kPa for 1 hour after engine stopped. Leaking valves in pressure regulator or fuel pump. Loose fuel pipe connections.</p>
Engine stalls when returning to idle from small throttle opening	<p>Idle speed too Low.</p>	<p>Reset idle speed.</p>
<p>Fuel pump noisy</p> <p>1. Under very hot conditions</p> <p>2. Under normal conditions</p>	<p>Aerated fuel due to low fuel level in tank combined with very hot fuel.</p> <p>Filter on fuel pickup in tank restricted.</p> <p>Rear fuel damper inoperative.</p> <p>Rubber mounting cushions on fuel pump bracket defective.</p> <p>Pump worn out.</p>	<p>No action required if quiet under normal conditions. Will not damage pump.</p> <p>Remove sender unit from tank and clean filter.</p> <p>Replace damper.</p> <p>Repair pump mounting system.</p> <p>Replace fuel pump.</p>

6C-64 ENGINE FUEL

5. SPECIFICATIONS

Air Flow System Components:

Air Flow Meter:

Nominal air flow 500 m³/hr

Auxiliary Air Valve:

Air flow 17 ± 2 m³/hr

Average time to shut at

+20°C and 14 volts 4 minutes

Nominal resistance 30 – 40 ohms

Leakage 1.0 m³/hr (maximum with slotted disc closed)

Fuel Section:

Fuel Pump:

Flow capacity minimum 130 l/hr at 12 volts and 303 kPa pressure

Fuel Pressure:

At idle 250 kPa

The moment the accelerator pedal

is depressed (zero engine vacuum) 300 kPa

Fuel Filter:

Flow rate 1.5 l/hr

Pressure drop 10 kPa maximum at 120 l/hr

Filter area 3000 cm²

Average pore size 8 – 10 micro metre

Injector:

Static flow 185 cm³/min ± 3% at 303 kPa

Dynamic flow 4.38 cm³/1000 strokes ± 3% at above atmospheric pressure

Permissible leakage 0.015 cm³/min at 303 kPa above atmospheric pressure
(1 drop/min)

Pressure Regulator:

Fuel pressure 303 kPa ± 6 kPa at 40 l/hr with regulator vacuum
connection open to atmosphere.

Electrical Section:

Control Unit Calibration Summary:

Base calibration 3.4 milliseconds

Warm-up enrichment factor 1.2 at 20°C

After start enrichment factor 1.7 at 0°C

Cold start injection pulse 16 milliseconds at 0°C

Accelerator enrichment factor 1.3 below 50°C

Full load enrichment factor 8% increase

Fuel cut off on deceleration Until 1800 rpm

Coolant Temperature Sensor:

Temperature °C -10 ± 1 -20 ± 1 -80 ± 1

Resistance k ohms 8.26 – 10.56 2.28 – 2.72 0.290 – 0.364

Fuel Pump Control Relay:

Hold in voltage at terminal No.15 5.5 volts minimum

Hold in ignition pulses at terminal No.1 150 rpm minimum

Throttle Position Switch:

Idle contact opening angle 1.0° from idle end position

Idle contact closing angle 0.2° from idle end position

Full load contact closing angle 40° ± 2 from idle end position

Idle speed at normal operating temperature –

run-in engine 850 ± 50 rpm

Idle mixture at normal operating temperature –

run-in engine5 – 1.5% CO

6. TORQUE WRENCH SPECIFICATIONS

	Nm
Inlet Manifold Mounting Nuts	41 – 48
Exhaust Extractor Mounting Bolts and Nuts	41 – 48
EGR Mounting Bolts	20 – 25
EGR Feed Pipe to Inlet Manifold Bolts	20 – 25
EGR Feed Pipe to Manifold Nuts	27 – 36
Inlet Manifold Brace Bolt	20 – 25
Inlet Manifold Brace Nut to Cylinder Head Stud	20 – 25
Fuel Rail Mounting Bolts	20 – 27
Pressure Regulator Mounting Nut	25 – 30
Pressure Regulator Fuel Line Gland Nuts	25 – 30
Fuel Return Line Bracket to Rocker Cover Bolt	8 – 10.6
Fuel Return Line Bracket to Side Plate Bolt	4 – 10
Air Cleaner Housing Mounting Nuts	8 – 10.6
Air Duct to Support Bracket Bolt	20 – 27
Throttle Body Mounting Nuts	8 – 10.6
Throttle Cable Lock Nuts	2 – 4
Fuel Pump Support Bracket Nuts	15 – 25
Fuel Pump Insulators	15 – 25
Rear Fuel Clamper Mounting Nut	15 – 25
Mounting Plate for Support Bracket Bolts	15 – 25
Fuel Filter Support Bracket Nuts	3 – 4
Throttle Valve Switch Mounting Screws	1 – 1.5
Fuel Pipe Hose Clamps	1
Air Flow Meter Mounting Bolts	8 – 11
Air Flow Meter Harness Retainer Bolt	20 – 27

6C-66 ENGINE FUEL

7. SPECIAL TOOLS

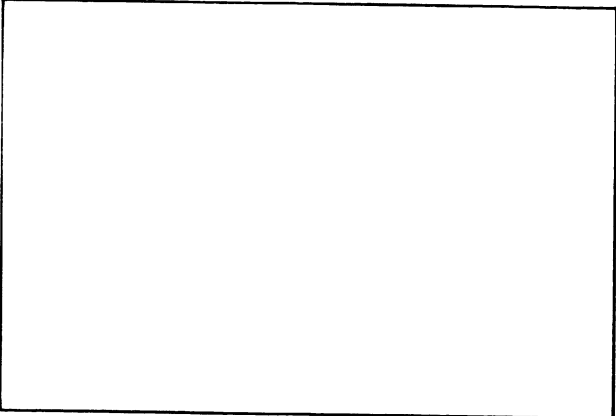
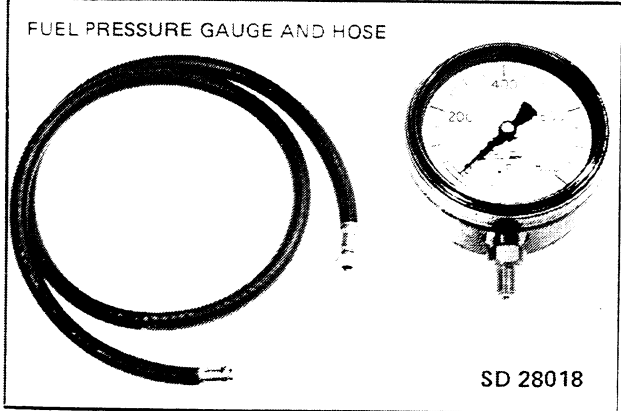

CARBURETTOR (3.3 EST)

INDEX

Ref.	Subject	Page	Ref.	Subject	Page
1.	GENERAL DESCRIPTION	6C-67	3.1	CARBURETTOR	6C-70
1.1	CARBURETTOR	6C-67		Remove.....	6C-70
2.	MINOR SERVICE OPERATIONS	6C-68		Disassembly.....	6C-70
2.1	CARBURETTOR ADJUSTMENTS 'ON			Checks	6C-72
	VEHICLE'	6C-68		Reassembly	6C-73
	Choke Operation	6C-68		Adjustment.....	6C-75
	Idle Speed Adjustment.....	6C-68		Reinstall	6C-79
	Fast Idle Adjustment.....	6C-68	4.	DIAGNOSIS	6C-80
2.2	THROTTLE POSITION SWITCH		5.	SPECIFICATIONS	6C-85
	ADJUSTMENT	6C-68	6.	TORQUE WRENCH SPECIFICATIONS.....	6C-86
3.	MAJOR SERVICE OPERATIONS.....	6C-70	7.	SPECIAL TOOLS	6C-86

1. GENERAL DESCRIPTION

The fuel system employed on carburettored 3.3 litre VK Series engines is similar to VH 3.3 litre models, except

for revisions to the Varajet II carburettor as noted in this Section.

1.1 CARBURETTOR

The carburettor used on VK is a Varajet II. Differences between VH and VK models include, new float bowl design, deletion of the spark advance signal port and a high mass choke coil which holds the choke valve open for longer periods after the vehicle is switched off. There is also the addition of a delay valve in the choke vacuum break hose, to aid in quicker starting and a revised secondary air valve restraint mechanism (Refer No. 60, Fig. 6C-121). A throttle position switch has been added to the carburettor and is mounted on the air horn, refer Fig. 6C-117. The accelerator pump lever has incorporated a lever which actuates the throttle position switch. For throttle position switch operation refer to Section 6D, Ignition System, of this Supplement.

The internal calibration has been changed to suit the characteristics of the 3.3 litre EST engine. Calibration details are listed in the Specifications at the end of this Section.

WARNING: TO AVOID THE POSSIBILITY OF ALTERING THE CERTIFIED EMISSION CONTROL SETTING OF THE CARBURETTOR, NO MAJOR SERVICE OPERATIONS MAY BE CARRIED OUT ON IT DURING THE EARLY LIFE OF THE VEHICLE EXCEPT FOR REMOVAL AND INSTALLATION.

THE EXTENT OF THE WORK WHICH MAY BE CARRIED OUT ON VEHICLES WHICH HAVE COVERED LESS THAN 80,000 km IS SET OUT IN THE 'MINOR SERVICE OPERATIONS.' IF THIS IS INSUFFICIENT, THE CARBURETTOR MUST BE REPLACED.

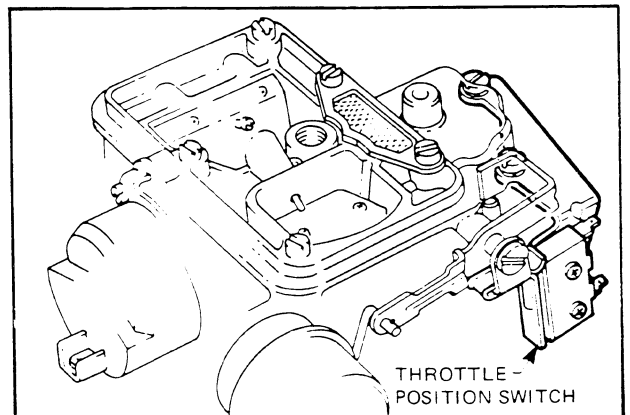

Figure 6C-117

6C-68 ENGINE FUEL

2. MINOR SERVICE OPERATIONS

2.1 CARBURETTOR ADJUSTMENTS 'ON VEHICLE'

CHOKE OPERATION

NOTE:

- a. Ensure cover index is set to specification, refer Fig. 6C-118 and specifications at the end of this Section.
 - b. Engine temperature must be within 5°C of ambient temperature.
1. Remove air cleaner and open and close throttle to set choke.
 2. Switch ignition on. Do not start engine.
 3. Depress and release the choke butterfly to enable the position of the control spring to be determined. The choke should be fully open within two to five minutes.

If the choke does not perform to specification, check for binding or stuck choke valve or linkage. If necessary, replace choke cover and bi-metallic coil assembly.

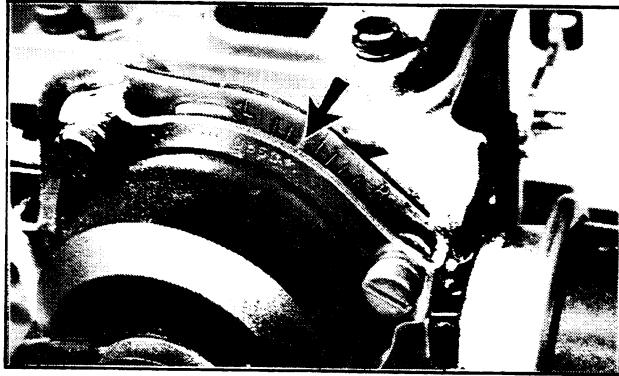

Figure 6C-118

IDLE SPEED ADJUSTMENT

1. Ensure spark plugs are correctly gapped.
2. Ensure engine is at normal operating temperature. (Drive 10 kms or idle engine for 15 minutes or more.)
3. Ensure choke is fully open.

NOTE: The throttle position switch must be closed.

4. Ensure throttle cable is adjusted correctly.
5. Ensure transmission is in Neutral or Park.
6. Ensure air conditioning is OFF.
7. Adjust mixture by-pass adjusting screw (shown in Fig. 6C-119) to set idle to specification.

WARNING: TO MAINTAIN DESIGNED EMISSION LEVELS, DO NOT ADJUST IDLE STOP SCREW OR IDLE MIXTURE SCREW.

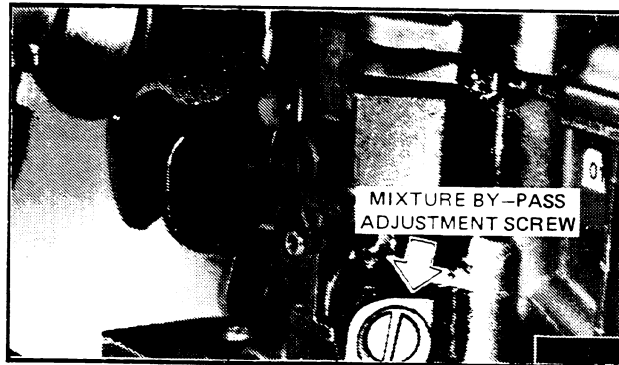

Figure 6C-119

FAST IDLE ADJUSTMENT

1. Engine at operating temperature.
2. Remove air cleaner. Plug vacuum hose to air preheat sensor.
3. Start engine.
4. Throttle position switch must be closed.

NOTE: The throttle position switch may be simulated in the closed position by removing both electrical connectors from the switch and connecting them together with a bridge wire.

5. With fast idle screw on lowest step of fast idle cam as shown in Fig. 6C-120, engine speed should be to specification. Adjust fast idle screw if necessary.

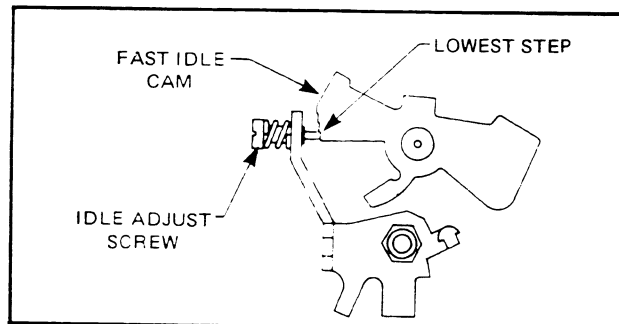
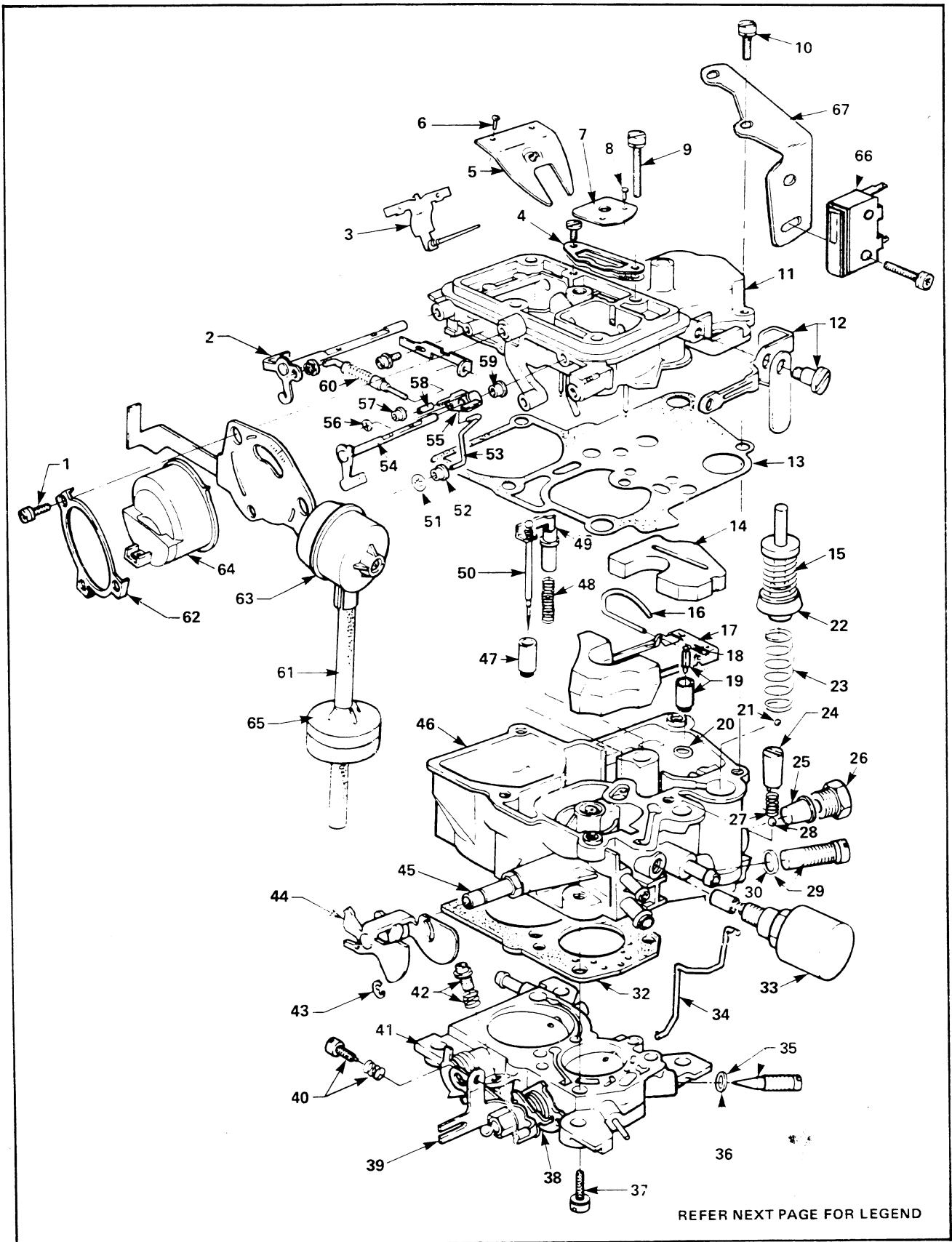

Figure 6C-120

2.2 THROTTLE POSITION SWITCH ADJUSTMENT

For adjustment instructions, refer to service operation 2.7 in Section 6D, Ignition System of this Supplement.

ENGINE FUEL 6C-69



REFER NEXT PAGE FOR LEGEND

Figure 6C-121

6C-70 ENGINE FUEL

LEGEND FOR FIGURE 6C-121

- | | | |
|--|--|--|
| 1. Retainer to vacuum brake screw | 24. Discharge pump retainer | 46. Float bowl |
| 2. Baffle flap shaft | 25. Carburettor fuel inlet filter | 47. Metering primary jet |
| 3. Needle retainer 2nd stage | 26. Carburettor fuel filter flare nut | 48. Power piston spring |
| 4. Air horn vent screen and retainer | 27. Discharge pump spring | 49. Power piston assembly |
| 5. Baffle flap | 28. Discharge pump ball | 50. Metering primary rod and spring asm. |
| 6. Baffle flap screw | 29. Mixture by-pass screw and seal asm. | 51. Choke link cam end clip |
| 7. Choke valve | 30. Mixture by-pass seal | 52. Choke link cam end bush |
| 8. Choke valve screw | | 53. Fast idle cam to choke link |
| 9. Air horn to float bowl screw | 32. Float bowl to throttle body gasket | 54. Choke shaft |
| 10. Air horn to float bowl screw | 33. Anti-dieseling solenoid | 55. Choke lever |
| 11. Air horn assembly | 34. Pump link | 56. Choke link clip |
| 12. Pump lever and screw assembly | 35. Idle needle screw and seal assembly | 57. Choke link bush |
| 13. Air horn to float bowl gasket | 36. Idle needle seal | 58. Coil contact sleeve |
| 14. Float pivot insert | 37. Throttle body to float bowl screw | 59. Choke lever bush |
| 15. Pump piston assembly | 38. Secondary drive spring | 60. Secondary shaft spring |
| 16. Float retainer pin | 39. Primary throttle lever | 61. Vacuum break hose |
| 17. Float and lever assembly | 40. Fast idle screw and spring assembly | 62. Choke cover and thermostat retainer |
| 18. Float lever to needle clip | 41. Throttle body | 63. Vacuum break housing and stem asm. |
| 19. Float needle valve and seat assembly | 42. Basic idle screw and spring assembly | 64. Cover and thermostat assembly |
| 20. Float needle valve seat seal | 43. Fast idle cam retainer | 65. Vacuum break delay valve |
| 21. Pump inlet ball | 44. Fast idle cam assembly | 66. Throttle position switch |
| 22. Piston cup | 45. Fast idle cam pivot | 67. Bracket |

3. MAJOR SERVICE OPERATIONS

3.1 CARBURETTOR

REMOVE

1. Disconnect battery earth cable.
2. Remove wing nut holding air cleaner and remove air cleaner.
3. Disconnect electrical leads, fuel line and vacuum hoses from carburettor.
4. Remove throttle linkage and cable assembly from bracket.
5. Remove carburettor to mount nuts and remove carburettor.

DISASSEMBLY

1. Remove fuel line flare nut and filter. Remove anti-dieseling solenoid.
2. Remove vacuum hose from throttle body and remove the three screws from choke retaining ring. Remove choke cover and vacuum break assembly (Fig. 6C-122).

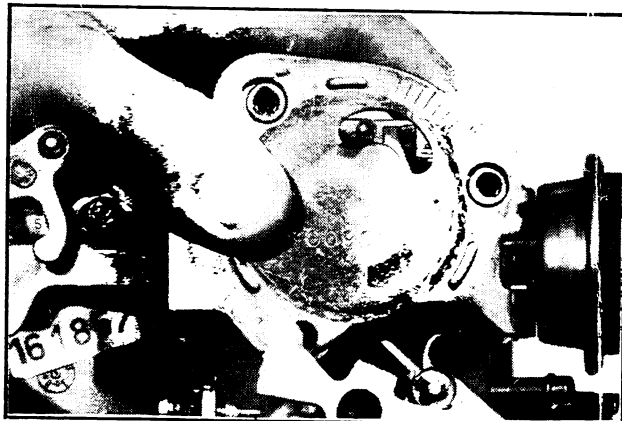

Figure 6C-122

3. Press off securing clip and withdraw choke valve link from fast idle cam slot (Fig. 6C-123).
4. Remove pivot screw from accelerator pump actuating lever.
5. Unscrew two short and four long retaining screws and remove air horn and throttle position switch assembly. Gasket remains on float bowl.

NOTE: The accelerator pump is spring loaded.

NOTE: Do not rest air horn on protruding tubes.

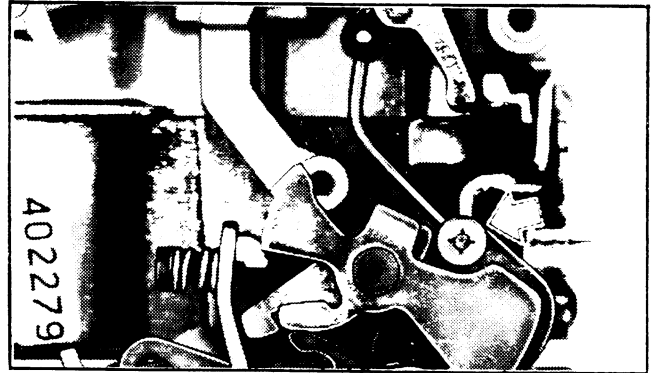

Figure 6C-123

6. Remove accelerator pump assembly (Fig. 6C-124).
7. Remove gasket.

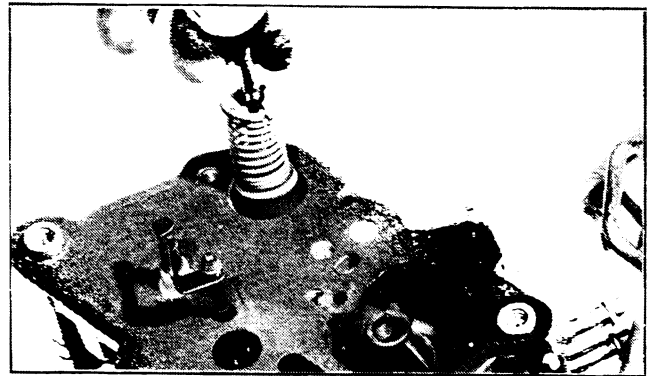

Figure 6C-124

8. Remove power piston assembly using a pair of side cutters and screwdriver as a fulcrum (Fig. 6C-125).

NOTE: Preferred method is to 'flick' the piston down and allow the spring to hammer against the plastic retaining sleeve. This is repeated until the assembly can be removed.

CAUTION: DO NOT LEVER UP ON HORIZONTAL TANG ABOVE POWER PISTON ASSEMBLY. GRIP POWER PISTON ACROSS INDENTATIONS IN BODY, ABOVE PLASTIC INSERT.

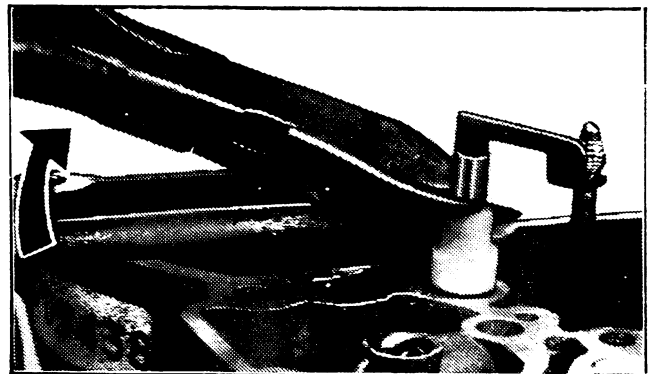

Figure 6C-125

9. Remove float pivot insert and float assembly (Fig. 6C-126).
10. Using a suitable screwdriver, remove seat and seal.

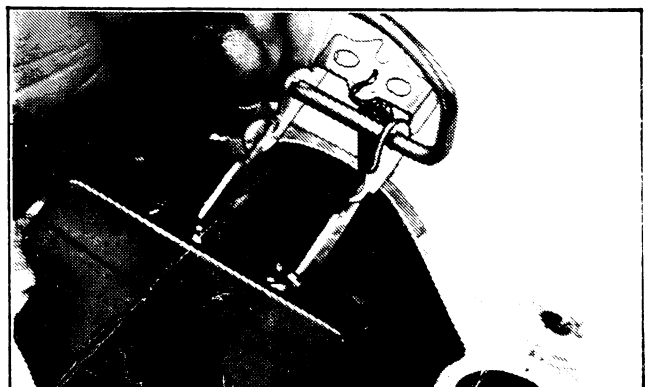

Figure 6C-126

6C-72 ENGINE FUEL

11. Using a suitable screwdriver, remove main jet (Fig. 6C-127).



Figure 6C-127

12. Remove four screws accessible from underside of carburettor and separate throttle body assembly from float bowl assembly (Fig. 6C-128).

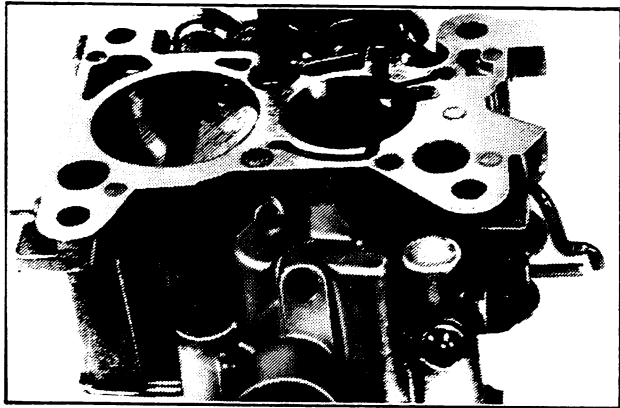

Figure 6C-128

CHECKS

Clean all parts in suitable cleaning fluid. Blow dry with compressed air. Jets and ports should be blown dry in normal direction of flow.

All mating surfaces should be cleaned and checked to ensure there are no imperfections.

With float bowl upright, fill pump area with fuel. Check that fuel level does not drop. If fuel is escaping, blow check ball passages out with compressed air.

Check main metering rod. Ensure rod is correct unit, see specifications. Replace if necessary.

Check throttle body linkage for freedom of movement. Ensure there is no binding of throttle valves (Fig. 6C-129).



Figure 6C-129

REASSEMBLY

1. Place gasket on inverted float bowl assembly. Ensure gasket is correctly located. Place throttle body assembly over gasket and retain with four screws. Re-check linkage operation (Fig. 6C-130).

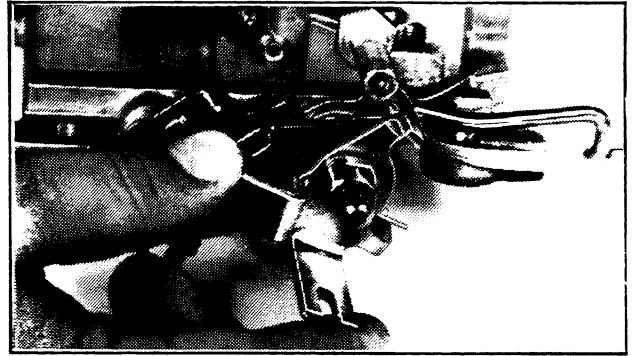

Figure 6C-130

2. Using a suitable screwdriver, reinstall needle valve seat and sealing ring.
3. Using suitable screwdriver, reinstall main jet (Fig. 6C-131).

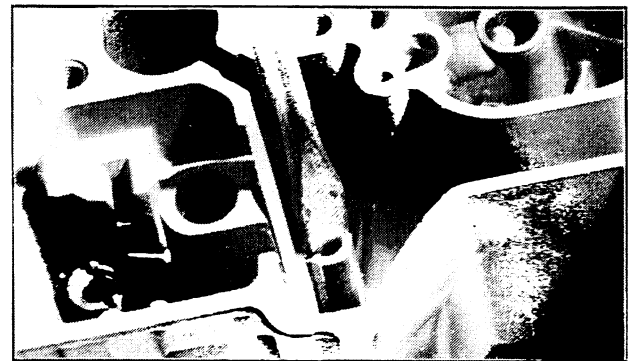

Figure 6C-131

4. Reinstall power piston and primary metering rod assembly. Remember spring under power piston (Fig. 6C-132).

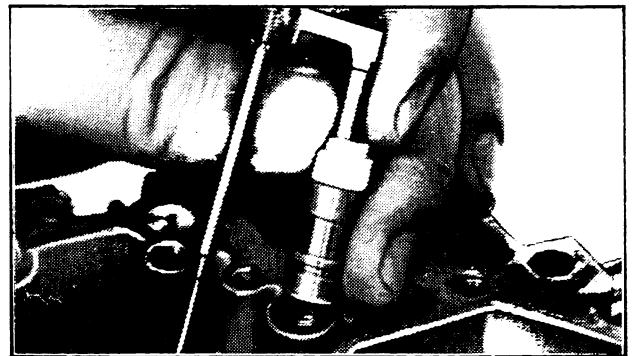

Figure 6C-132

5. Hook float needle valve on float arm. Reinstall float and needle valve assembly (Fig. 6C-133).

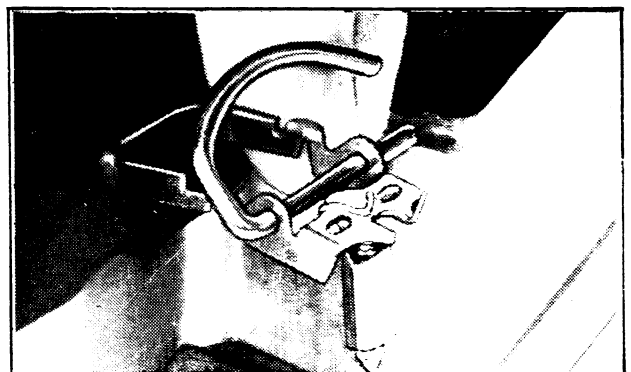

Figure 6C-133

6C-74 ENGINE FUEL

6. Hold needle valve actuating arm as shown and push down until valve rests on seat. Distance from top of float to top face of float bowl should be to specification (Fig. 6C-134).

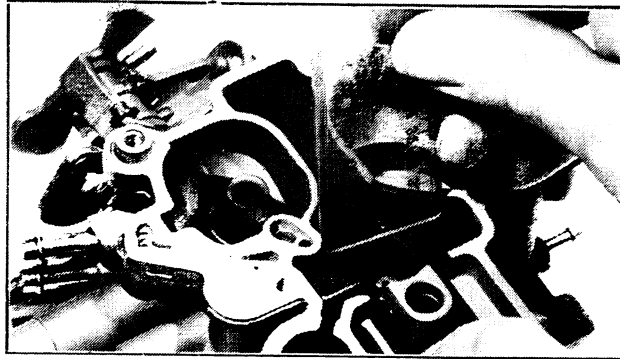

Figure 6C-134

Adjust if necessary by bending arm (Fig. 6C-135).

7. Reinstall float pivot insert. Reinstall gasket in correct orientation.

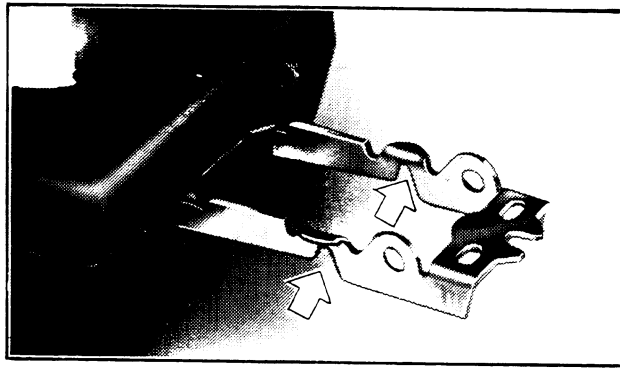

Figure 6C-135

8. Reinstall accelerator pump assembly (Fig. 6C-136).

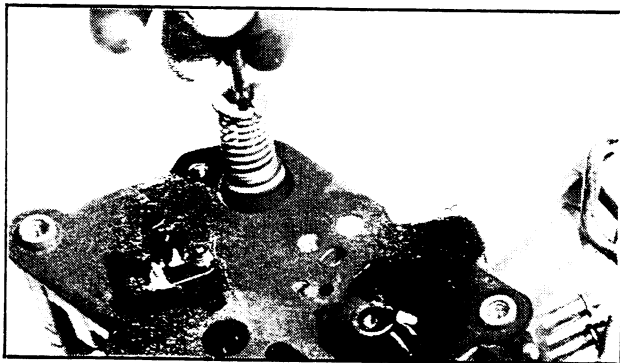

Figure 6C-136

9. Reinstall air horn assembly ensuring accelerator pump push rod passes through correct hole in air horn and gasket is correctly seated (Fig. 6C-137).
10. Reinstall accelerator pump actuating linkage on lever and reinstall pivot screw. Reinstall throttle position switch to air horn.

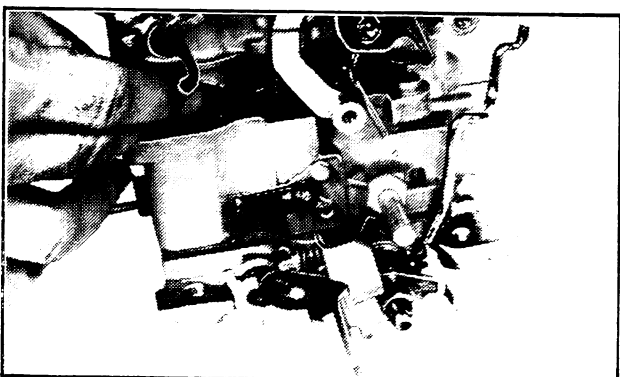

Figure 6C-137

11. Reinstall choke valve link into fast idle cam slot. Ensure plastic sleeve is in place. Replace securing clip (Fig. 6C-138).

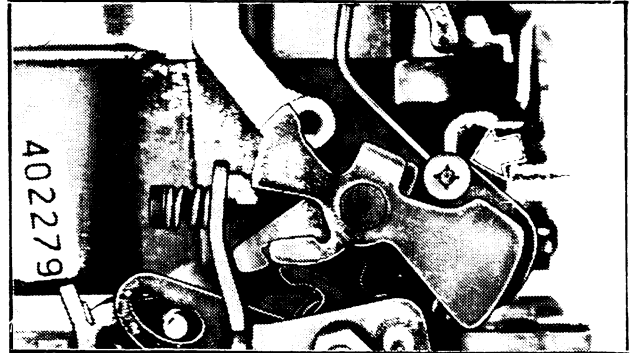

Figure 6C-138

12. Reinstall vacuum break assembly and choke cover. Ensure choke spring correctly engages choke actuating lever. Screw retaining ring in place, ensuring arrow on choke cover points to specified index mark (Fig. 6C-139).
Reinstall vacuum hose.
13. Reinstall filter, fuel inlet flare nut and anti-dieseling solenoid.

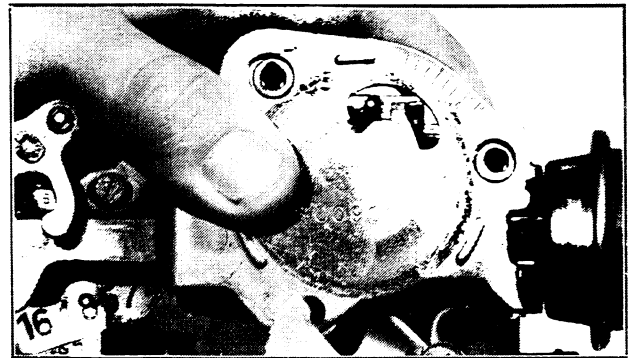

Figure 6C-139

ADJUSTMENT

Wide Open Throttle

1. Hold fast idle cam down and open throttle completely - ensure 2nd stage valve is open as well.
2. Measure clearance between tang on intermediate lever and spring end. Bend tang on intermediate lever to adjust (Fig. 6C-140). Check Specifications section for measurement.

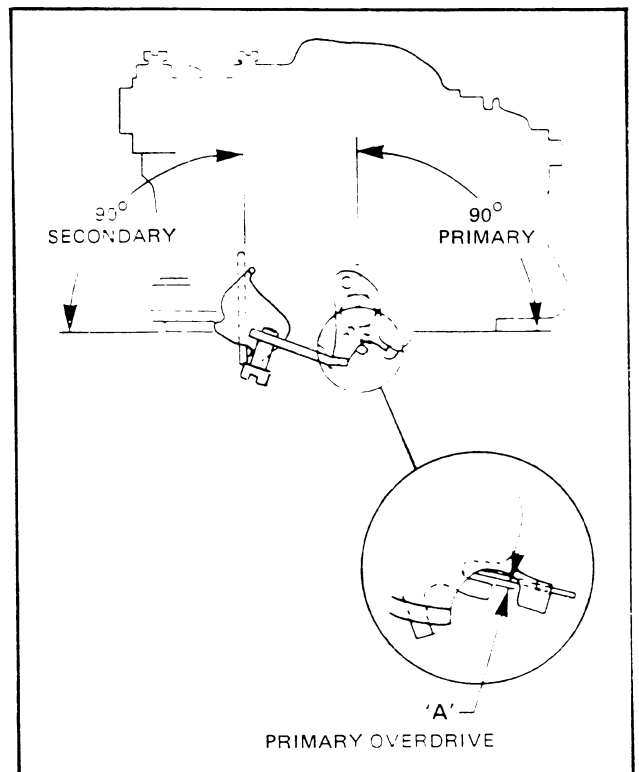

Figure 6C-140

6C-76 ENGINE FUEL

Secondary Throttle Opening

1. Open primary valve, ensuring secondary valve remains closed (lock engaged).
2. Measure clearance between tang on secondary throttle lever and intermediate lever. Bend tang on secondary throttle lever to adjust (Fig. 6C-141). See specifications for measurement.

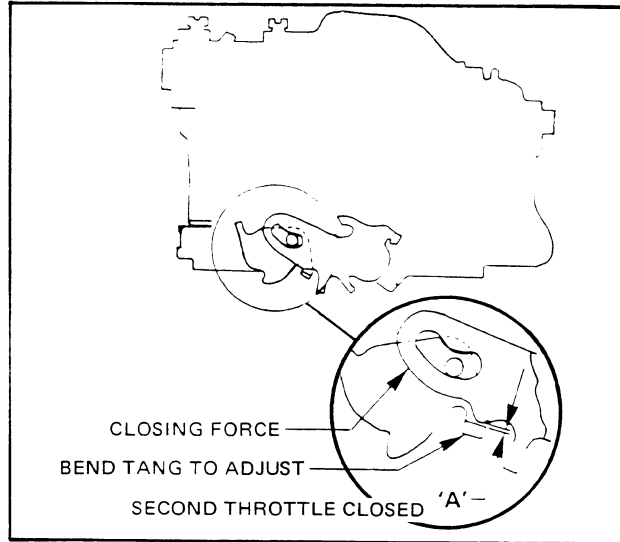

Figure 6C-141

Secondary Closing Setting

1. Idle stop lever against slow idle stop screw (Fig. 6C-142).
- Movement of secondary throttle valve should be to specification. Bend tang on intermediate lever to adjust.

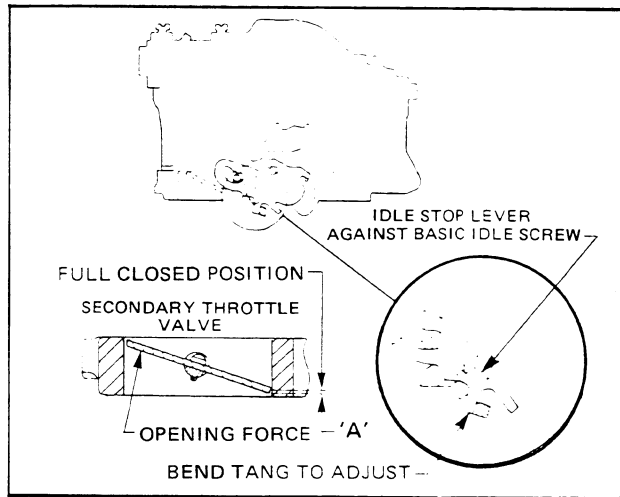

Figure 6C-142

Vacuum Break Settings

1. Choke Setting.
 - a. Set the automatic choke to closed.
 - b. Remove vacuum hose to vacuum break unit (Fig. 6C-143). Use hand vacuum pump J23937-01 or equivalent to apply vacuum to vacuum break unit to fully retract stem.

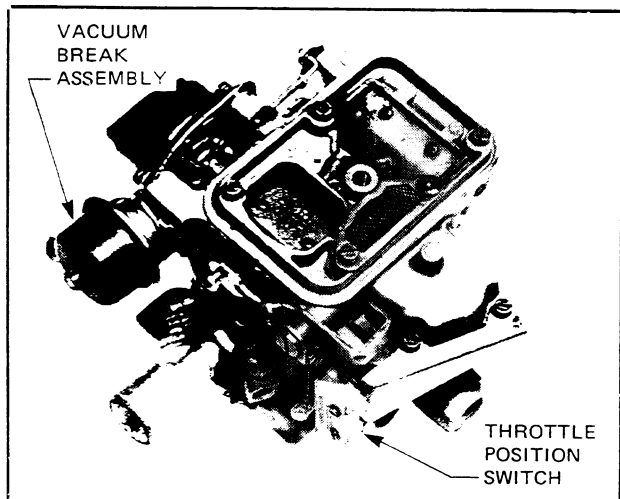

Figure 6C-143

Distance between choke valve and carburettor wall should be to specification (Fig. 6C-144).

Adjust by turning screw 'B' (Fig. 6C-144).

NOTE: This adjustment should be performed in conjunction with 'Air Valve Setting' below. (Remember that interference between air valve lever and vacuum break stem will affect travel of vacuum break stem.)

Lock stop screw with paint after adjustment.

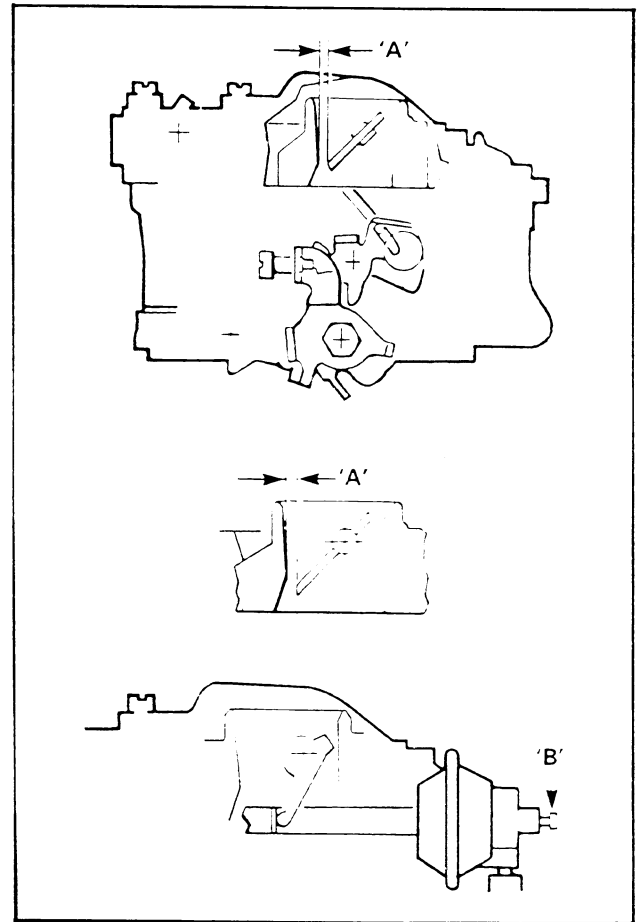

Figure 6C-144

2. Air Valve Setting

- a. Use J23987-01 or equivalent to apply vacuum to break unit.
- b. Clearance between air valve lever and vacuum break stem should be to specification (Fig. 6C-145).
- c. Bend tang to adjust.

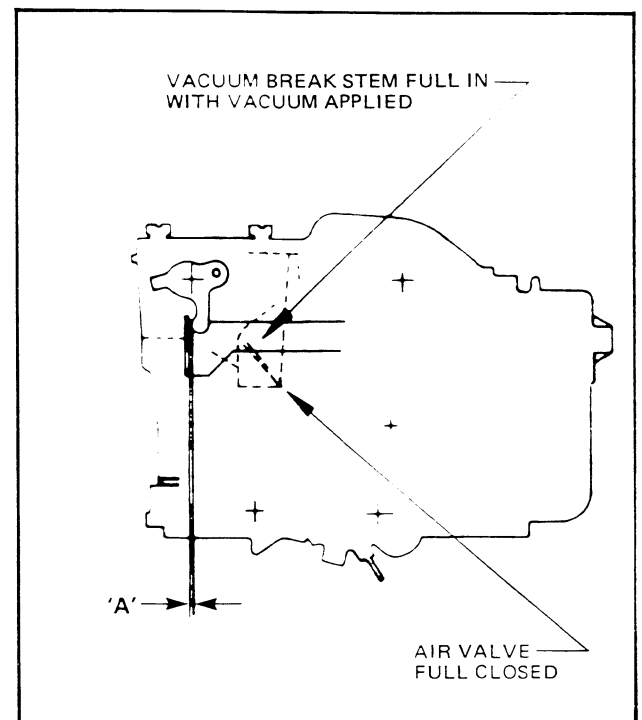

Figure 6C-145

6C-78 ENGINE FUEL

Second Step Setting

With choke coil cold (ambient temperature), ensure fast idle screw is seated on second highest or 2nd step of cam (Fig. 6C-146).

With light pressure applied on choke valve, clearance between valve and carburettor throat should be to specification.

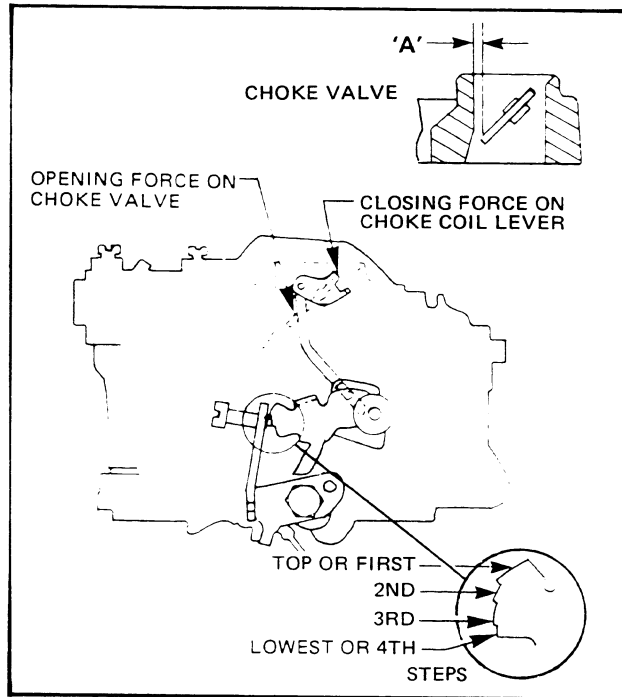

Figure 6C-146

Bend choke link to adjust (bending increases clearance, straightening reduces clearance). See Fig. 6C-147.

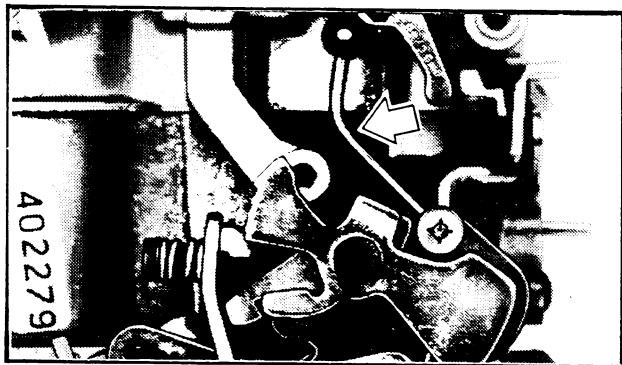

Figure 6C-147

Wide Open Kick Setting

1. Choke valve held closed.
2. Primary throttle lever held fully open.
3. Push choke valve against kick lever to remove backlash.

Dimension A, choke valve to carburettor throat clearance, should be to specification (Fig. 6C-148).

Bend lever on fast idle cam to adjust.

NOTE: Secondary throttle lockout lever must be fully engaged in tang on intermediate lever.

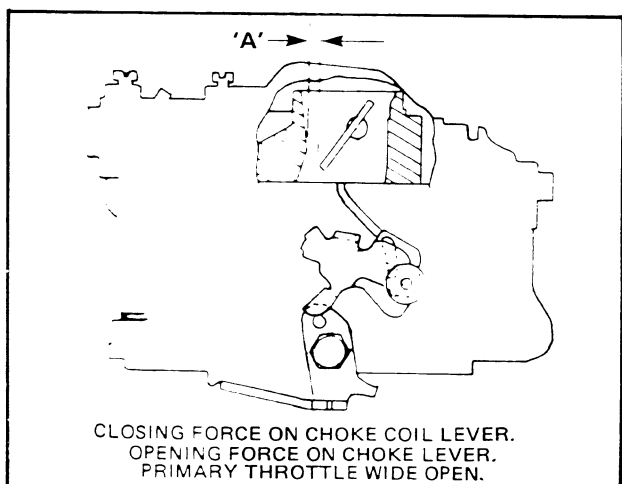

Figure 6C-148

Secondary Lockout Lever Rotation

1. Choke control lever held fully open (use elastic band to overcome automatic choke closing force.)

Clearance between secondary lockout lever and tang on intermediate lever should be to specification (Fig. 6C-149).

If dimension is incorrect, check 'Secondary Lockout Setting' below.

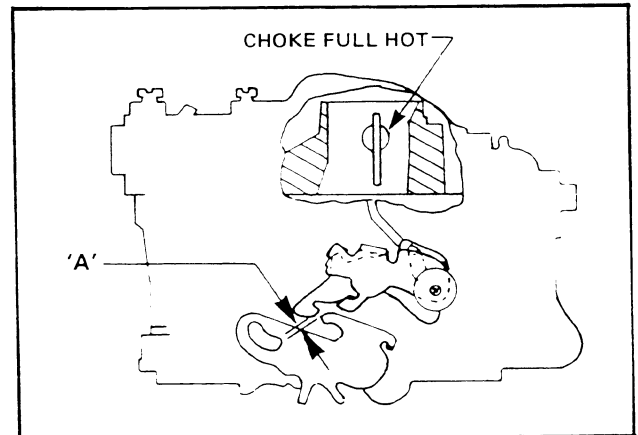

Figure 6C-149

Secondary Lockout Setting

1. Choke control lever closed.
2. Primary throttle lever wide open.
3. Secondary lockout lever fully engaged. Secondary throttle valve should have clearance as specified (Fig. 6C-150).

Bend tang on secondary valve lever to adjust.

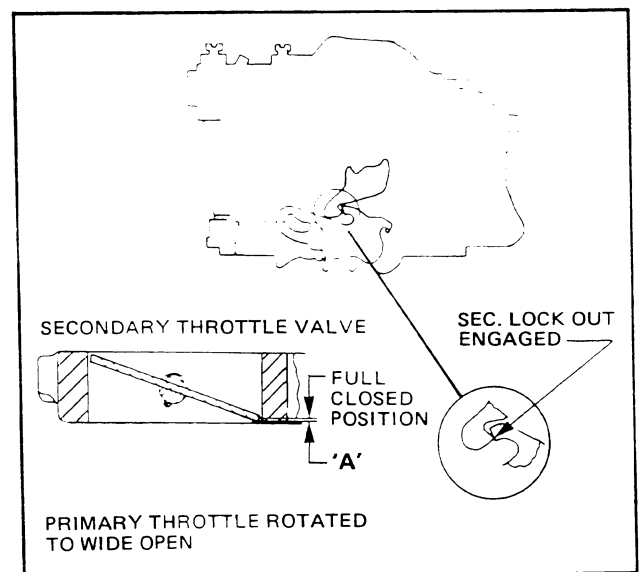

Figure 6C-150

Accelerator Pump

1. Throttle closed, carburettor set for idle, choke held off.
2. Slowly depress accelerator pump plunger until secondary spring resistance is felt. The distance travelled from rest position should be to specifications (Fig. 6C-151).
3. Bend pump arm to adjust (at B).
4. Readjust throttle position switch if pump arm is bent. Refer to Section 6D of this Supplement for details.

REINSTALL

1. Clean all mating surfaces. Take care that material does not fall into manifold.
2. Using new gasket, install carburettor. Torque nuts to specification.
3. Reinstall fuel line, electrical leads and vacuum hoses.
4. Reinstall air cleaner. Torque nut to specification.
5. Install air pre-heat, engine ventilation and vacuum hoses on air cleaner.

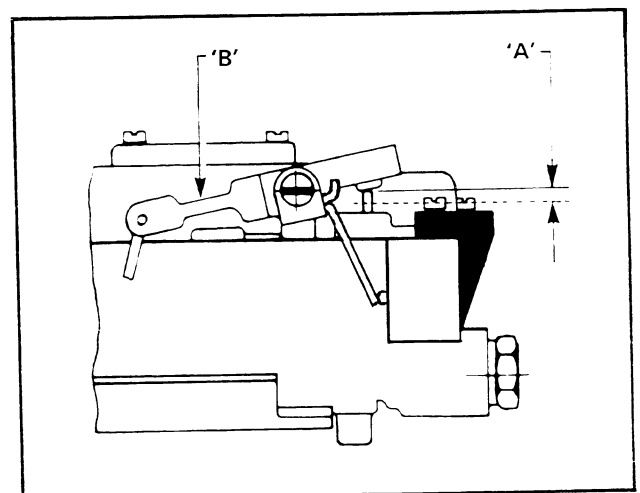
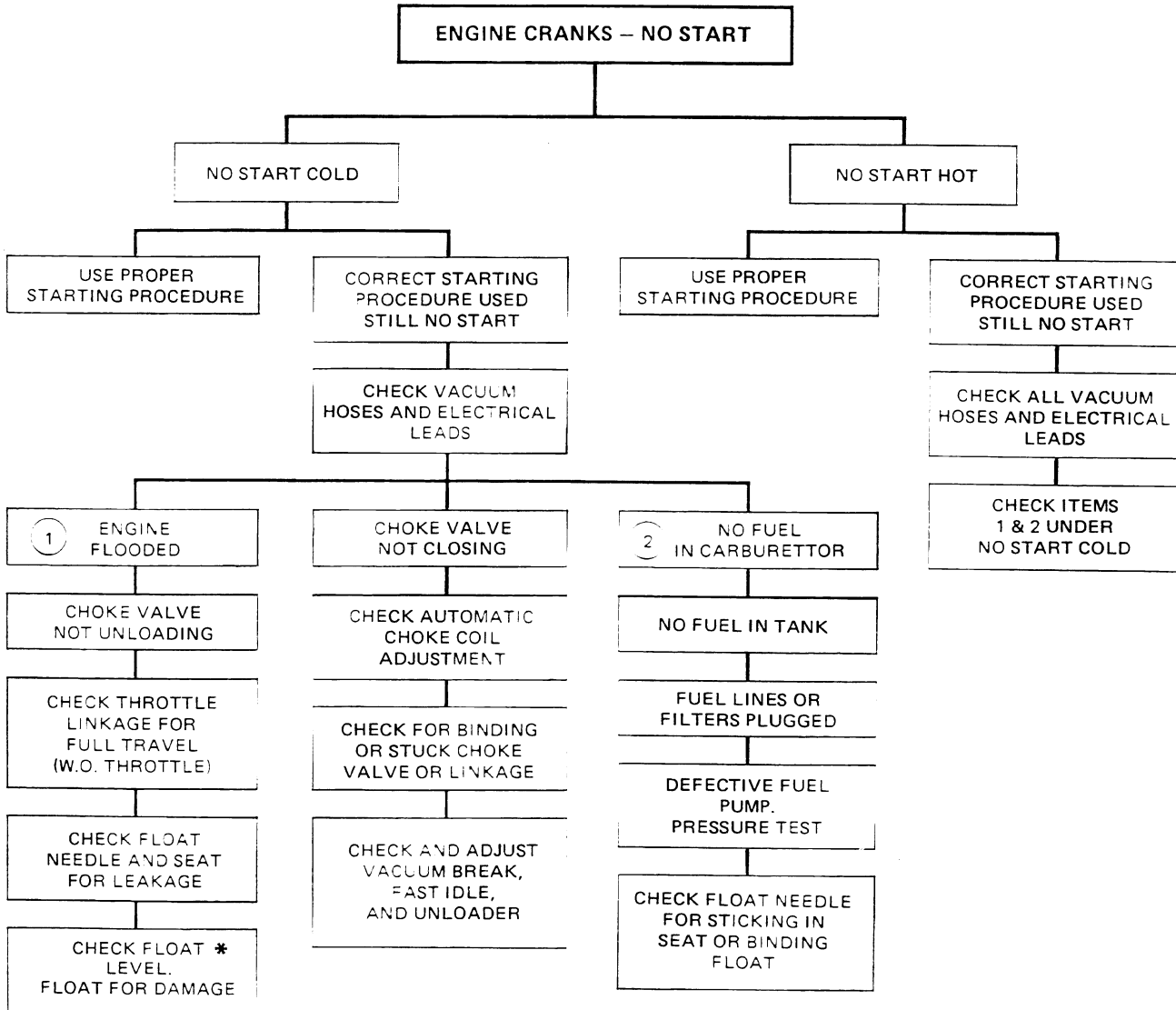

Figure 6C-151

6C-80 ENGINE FUEL

4. DIAGNOSIS

The following Diagnosis Charts must not be taken as approval to carry out major operations on vehicles with less than 80,000 kms.



* DO NOT ADJUST FLOAT LEVEL EXCEPT AFTER MAJOR OVERHAUL

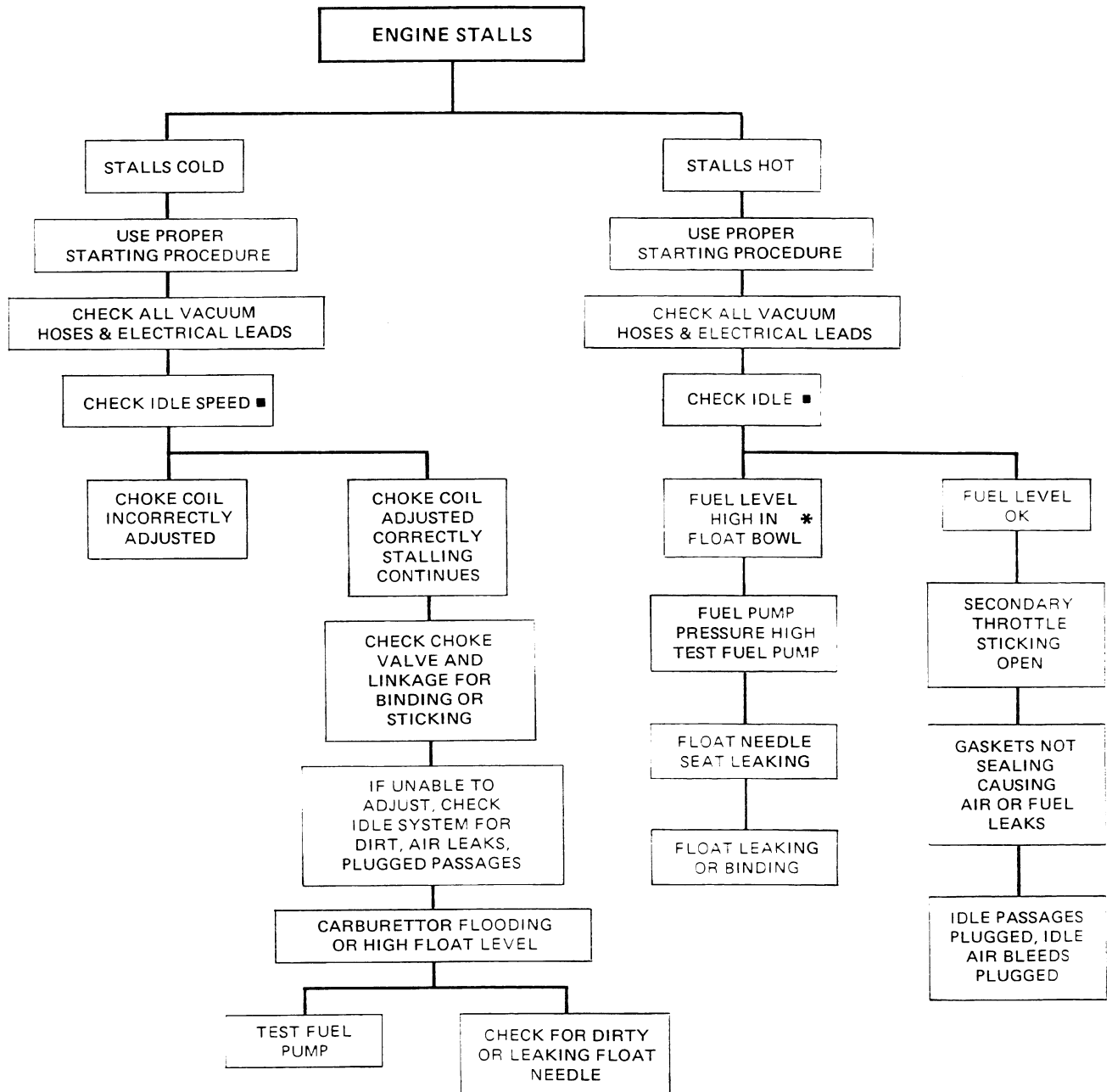

* DO NOT ADJUST FLOAT LEVEL EXCEPT AFTER MAJOR OVERHAUL

■ REFER SECTION 2 FOR CORRECT ADJUSTMENT PROCEDURE.

6C-82 ENGINE FUEL

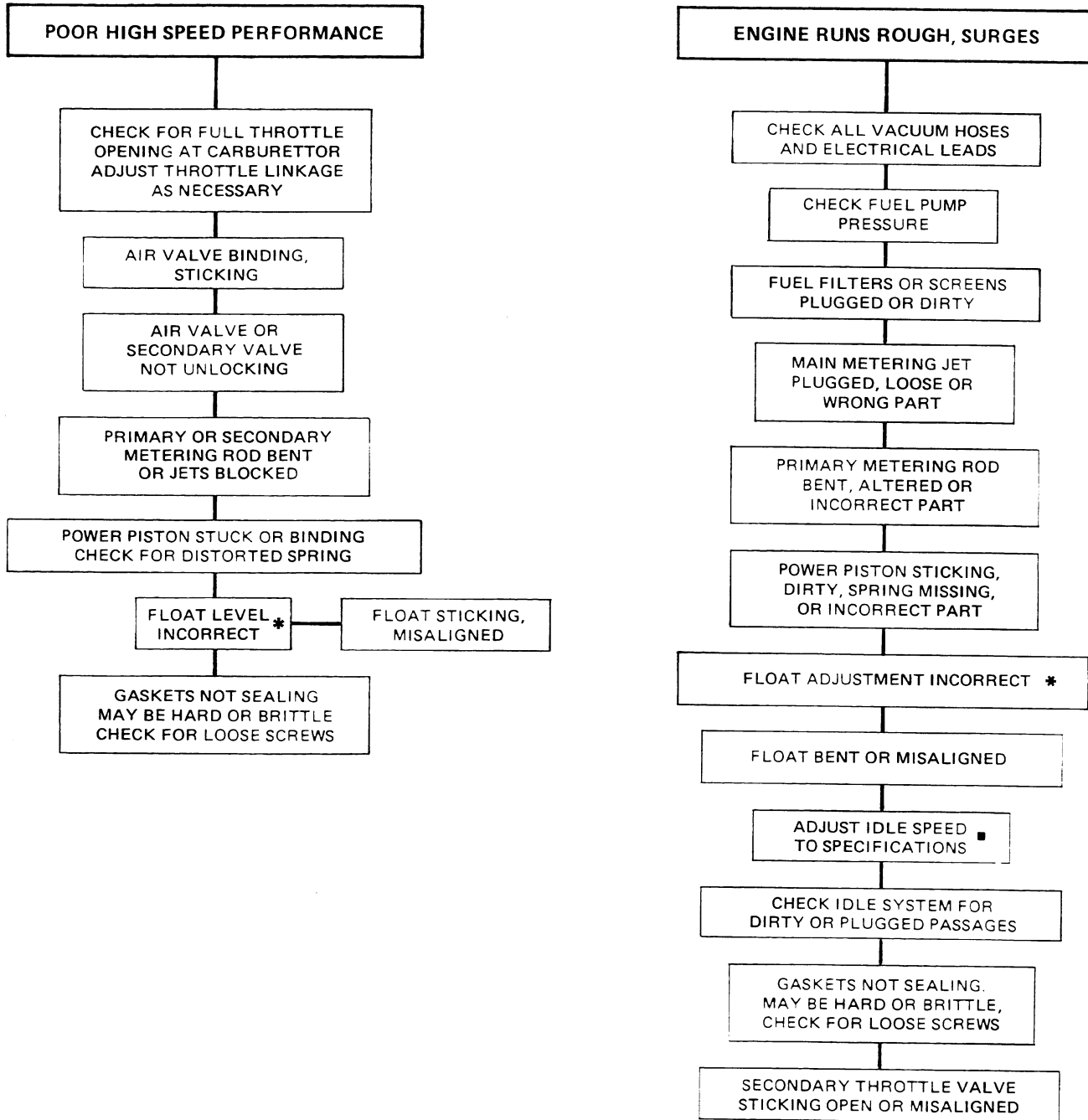

* DO NOT ADJUST FLOAT LEVEL EXCEPT
AFTER MAJOR OVERHAUL

■ REFER SECTION 2 FOR CORRECT
ADJUSTMENT PROCEDURE.

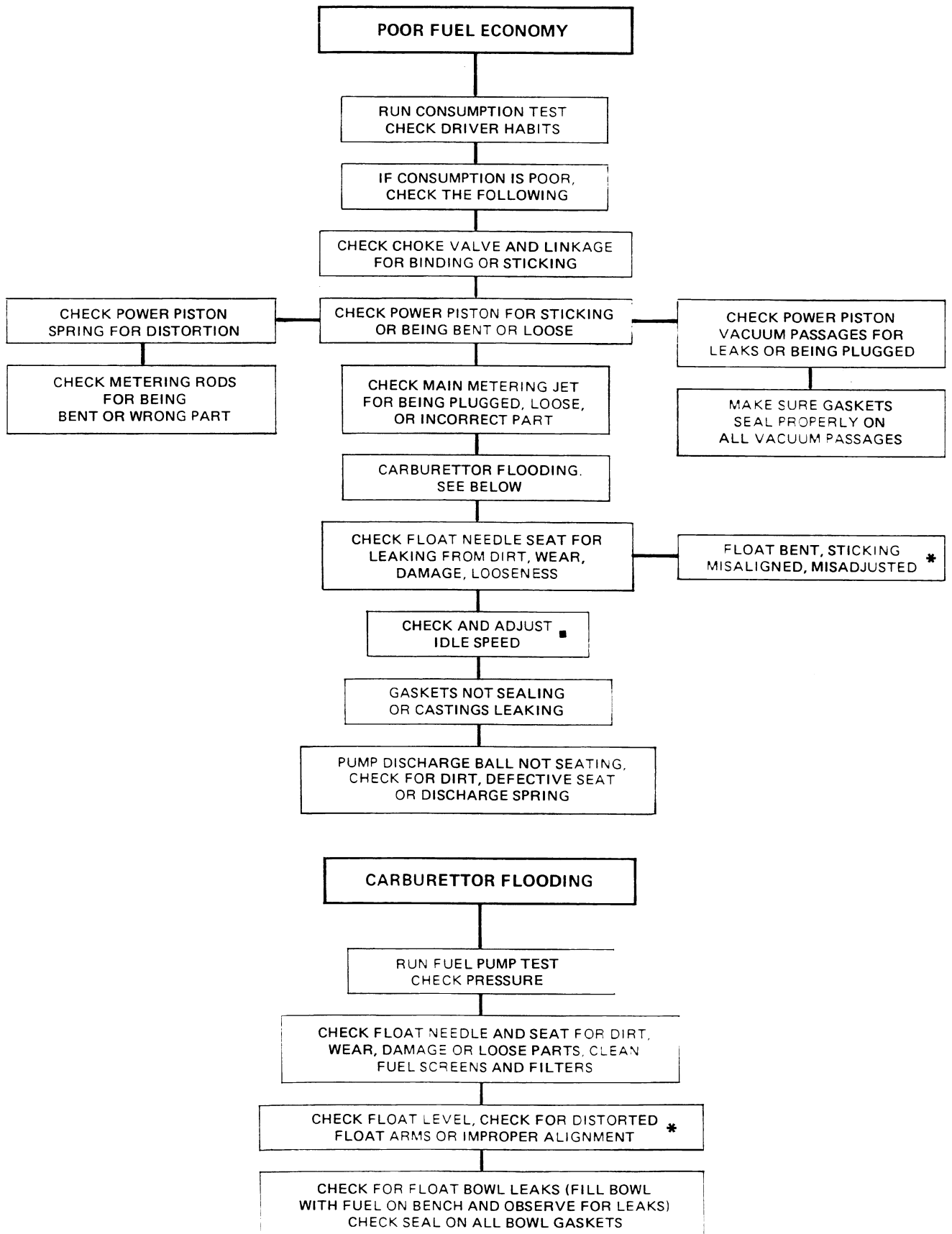

* DO NOT ADJUST FLOAT LEVEL EXCEPT AFTER MAJOR OVERHAUL

■ REFER SECTION 2 FOR CORRECT ADJUSTMENT PROCEDURE.

6C-84 ENGINE FUEL

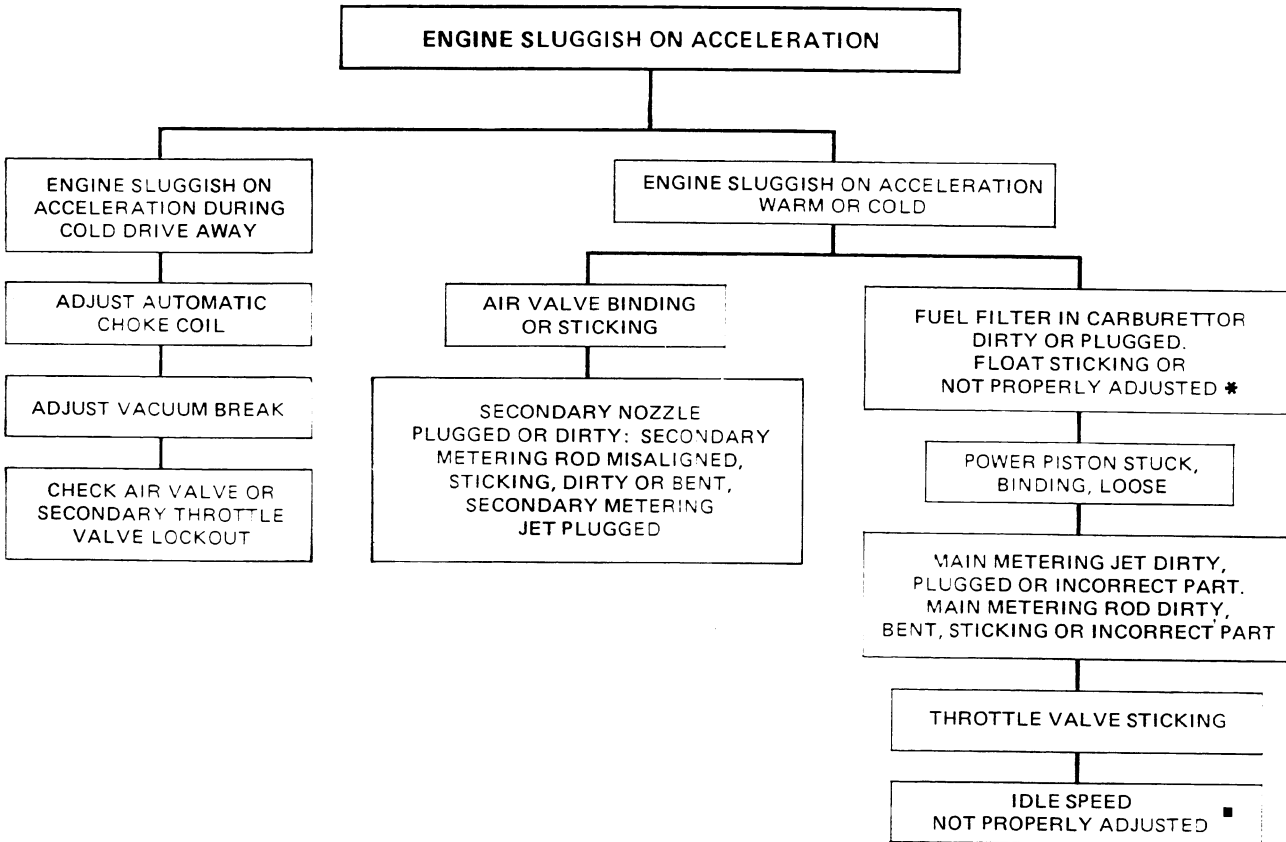
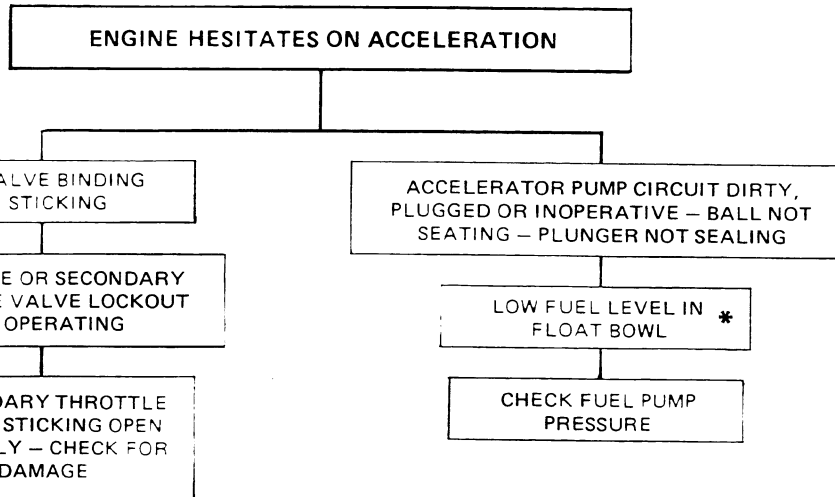

* DO NOT ADJUST FLOAT LEVEL EXCEPT AFTER MAJOR OVERHAUL.

■ REFER SECTION 2 FOR CORRECT ADJUSTMENT PROCEDURE.

5. SPECIFICATIONS

CARBURETTOR – 2 Barrel Varajet II

Calibration Item (Automatic and Manual Transmission)

P.O.E. Bleed	1.42 mm	Idle Tube	0.65 mm
P.O.E. Nozzle	1.85 mm	M.B.P. Restriction	1.60 mm
P.O.E. Tube	0.65 mm	Top M.B.P. Inlet	5.50 mm
Secondary Metering Jet	3.20 mm	M.B.P. Down Channel in Float Bowl	7.00 mm
Secondary Metering Rod Full dia.	2.975 mm	Primary Metering Rod	1.18 mm
Secondary Metering Rod Tip dia.	1.970 mm	Primary Metering Jet	1.83 mm
Secondary Air Bleed	1.00 mm	Idle Needle Orifice	2.20 mm
Primary Nozzle Relation	3.50 mm	Idle Port Width	0.70 mm
Main Well Boost Bleed	1.00 mm	Idle Port Length	3.00 mm
Auxiliary Well Bleed	1.00 mm		

NOTE: P.O.E. Pull Over Enrichment

M.B.P. Mixture By-Pass

FUEL PUMP:

Pressure Test 22 – 26 kPa @ 1000 rpm

ADJUSTMENT SPECIFICATIONS (AUTOMATIC & MANUAL TRANSMISSIONS)		
FIG. REF.	ITEM	SPEC.
N.A.	LIQUID FUEL LEVEL (Fuel level to float bowl top – no gasket)	17.0 mm
6C-134	DRY FLOAT LEVEL SETTING (Float top to fuel bowl top – no gasket)	8.0 mm
6C-140	WIDE OPEN THROTTLE – PRIMARY	90 Deg.
6C-140	WIDE OPEN THROTTLE – SECONDARY	90 Deg.
6C-140	WIDE OPEN THROTTLE – PRIMARY OVERDRIVE	"A" = 0.5 mm
6C-141	SECONDARY THROTTLE OPENING INITIAL	"A" = 0.45 mm
6C-142	SECONDARY CLOSING SETTING	"A" = 0.60 mm
6C-144	CHOKE SETTING	"A" = 4.2 mm
6C-145	AIR VALVE SETTING	"A" = 0.3 mm
6C-146	SECOND STEP SETTING	"A" = 3.70 mm
6C-148	WIDE OPEN KICK SETTING	"A" = 10.0 mm
6C-149	SECONDARY LOCKOUT LEVER ROTATION	"A" = 2.0 mm
6C-150	SECONDARY LOCKOUT SETTING	"A" = 0.4 mm
6C-151	ACCELERATOR PUMP SETTING	"A" = 8.0 mm
N.A.	PUMP CAPACITY FOR 10 SLOW STROKES	14.5 cc
N.A.	CHOKE COVER INDEXING	1 N.L.
N.A.	AIR VALVE OPENING	84 Deg.
N.A.	CHOKE OPENING TIME AT 22°C	2 – 3 mins

ENGINE IDLE SPEED

(In Neutral – Manual Transmission, Park – Auto Transmission

Air Conditioning "OFF", Engine Warm) 850 ± 25 rpm

ENGINE FAST IDLE SPEED

Lowest step of fast idle cam 1,150 ± 25 rpm

6C-86 ENGINE FUEL

6. TORQUE WRENCH SPECIFICATIONS

	Nm
Carburettor to Manifold Stud Nuts	14 – 16
* Air Cleaner Stud	10
Throttle Position Switch to Mounting Screws	0.5 – 0.7
Throttle Position Switch Mounting to Air Horn Screws	3.5 – 4.5
Throttle Linkage Bracket to Manifold Bolts	12 – 16
Accelerator Cable Lock Nuts	3 – 4

* Use thread locking sealant such as Loctite 675.

7. SPECIAL TOOLS

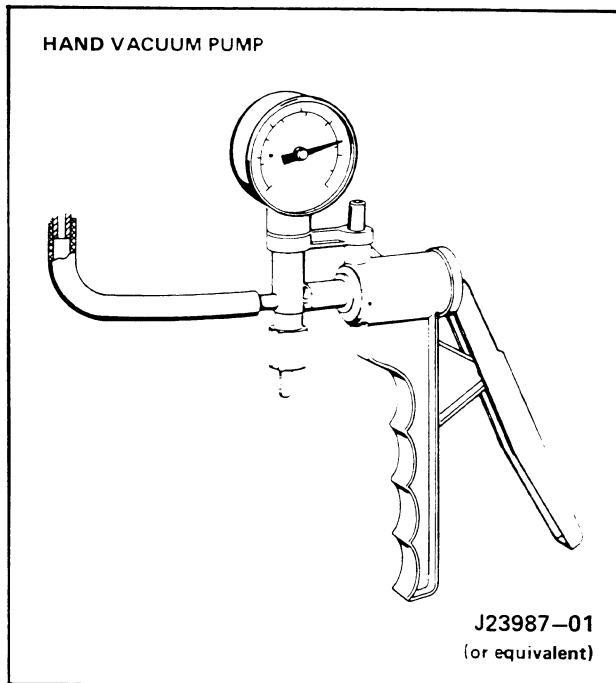

5.0 LITRE ENGINE FUEL SYSTEM

INDEX

Ref.	Subject	Page	Ref.	Subject	Page
1.	GENERAL DESCRIPTION	6C-87	2.3	FUEL FLOW TEST	6C-88
2.	SERVICE OPERATIONS	6C-88	2.4	PUMP PRESSURE TEST	6C-89
2.1	FUEL PUMP	6C-88	2.5	CONTROL RELAY OPERATION	6C-89
	Remove.....	6C-88		Battery Supply Voltage	6C-89
	Reinstall	6C-88		Ignition Supply Voltage	6C-89
2.2	CONTROL RELAY	6C-88		Control Relay Output	6C-89
	Remove.....	6C-88	3.	SPECIFICATIONS	6C-90
	Reinstall	6C-88			

1. GENERAL DESCRIPTION

All 5.0 litre VK Series models are equipped with a revised fuel pump system to improve driveability in high ambient temperature conditions.

The mechanical fuel pump has been deleted, a cover plate is added to the fuel pump access hole on the timing case cover. The inline plastic fuel filter has been deleted and replaced by a revised fuel vapour separator incorporating a gauze filter screen, refer Fig. 6C-152.

The revised fuel pump system includes, an electric fuel pump mounted on the fuel gauge tank unit, inside the fuel tank, refer Fig. 6C-153. The operation of the fuel pump is controlled by a control relay inside the fuse box. The principle of operation is the same as described for the EFI system control relay, refer to 'Electronic Fuel Injection' in Section 6C of this Supplement. The fuel lines have also been revised with the deletion of the mechanical fuel pump and inline filter.

The float level height has also been revised to 11.5 mm (.460 ins.). Refer to the Section 10 'Engine Tune Up' of the Improved Performance Engine Service Manual Part No. M38338, for adjustment procedures.

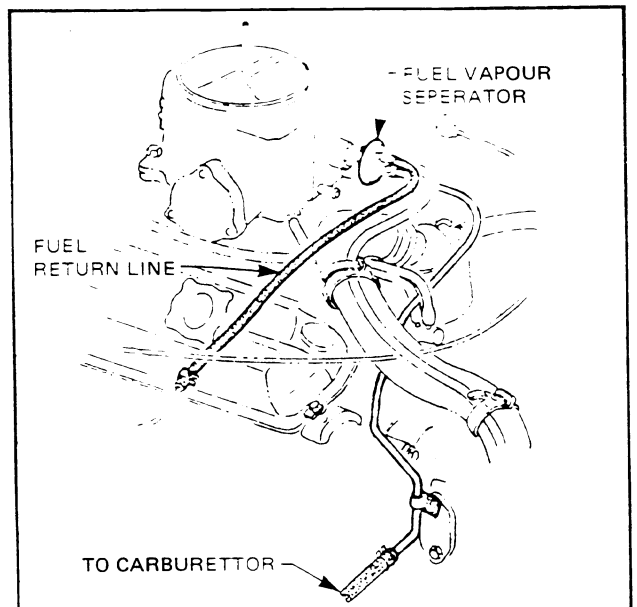

Figure 6C-152

6C-88 ENGINE FUEL

2. SERVICE OPERATIONS

2.1 FUEL PUMP

REMOVE

1. Remove fuel gauge tank unit, refer to service operation 2.6, Section 12C of this Supplement.
2. Disconnect wiring from tank unit to fuel pump.
3. Remove filter from pump. Slide upper rubber connector from fuel pump outlet, then remove pump by sliding out from lower bracket.

REINSTALL

Installation is reversal of removal procedure.

NOTE: The electric fuel pump is a sealed unit and non repairable.

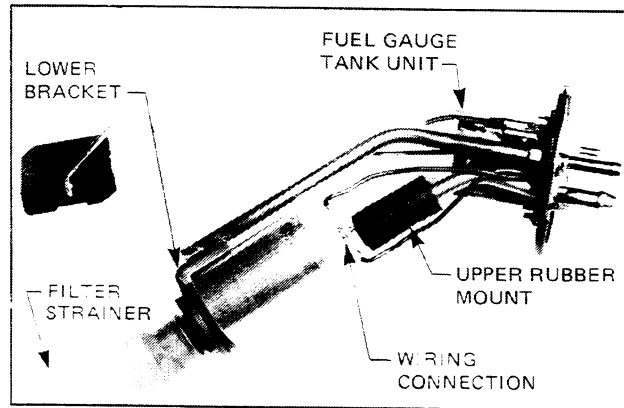

Figure 6C-153

2.2 CONTROL RELAY

REMOVE

1. Remove fuse box cover.
2. Pull out relay from its position in the fuse box, refer Fig. 6C-155.

REINSTALL

Installation is reversal of removal procedures.

If the engine fails to start and the normal diagnosis procedure indicates a fault in the fuel supply to the carburettor, check fuel pump pressure and fuel flow.

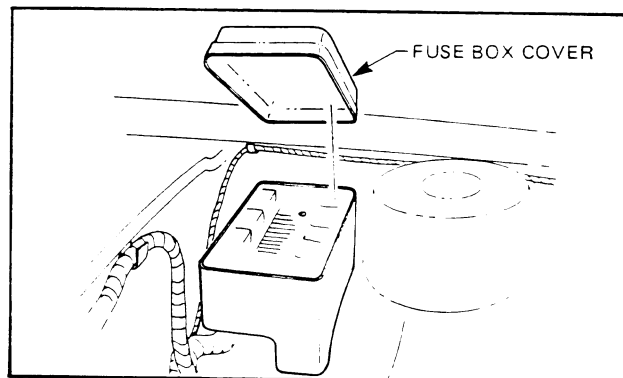

Figure 6C-154

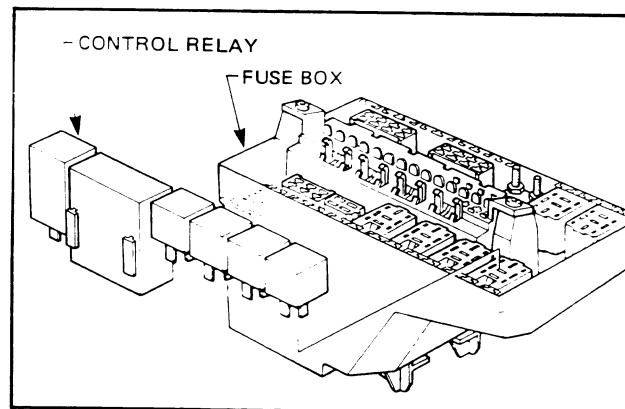

Figure 6C-155

2.3 FUEL FLOW TEST

1. Disconnect the carburettor fuel line at the carburettor - prior to the vapour separator.
2. Disconnect '+' wire at ignition coil terminal, place a suitable container at the end of the fuel line and crank the engine a few revolutions. If little or no fuel flows from the open end of the pipe, then the fuel pipe is blocked or fuel pump is inoperative.

2.4 PUMP PRESSURE TEST

If fuel flows in good volume from the pipe at the carburettor, fuel delivery pressure may then be checked. This test is necessary because a weak pump can still produce an adequate volume of fuel when it is not under pressure.

1. Install a suitable adaptor and tee fitting to the fuel line at the carburettor fuel inlet line. Fit a short rubber hose to the tee piece and attach the other end to a pressure gauge having a scale reading to at least 60 kPa.
2. Start the engine and run at idle, note reading on pressure gauge.
3. If the pump is operating correctly, the pressure should be approximately 30-40 kPa after 30 seconds of running.

2.5 CONTROL RELAY OPERATION

BATTERY SUPPLY VOLTAGE

1. Remove control relay as per 2.2.
2. Check for voltage supply to the terminal corresponding to terminal 30 of control relay and earth, refer Fig. 6C-156. If not, check for continuity of wiring to terminal. Refer to wiring diagrams in Section 12F of this Supplement. If O.K. proceed to next test.

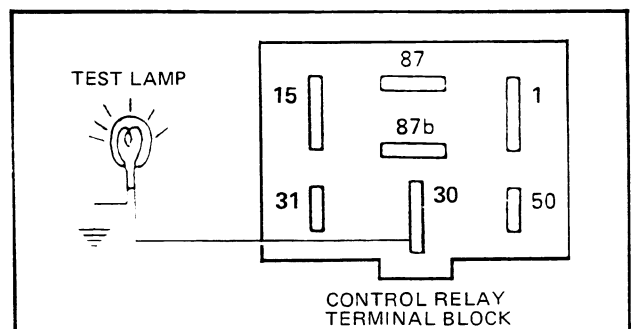

Figure 6C-156

IGNITION SUPPLY VOLTAGE

1. With control relay still removed and vehicle ignition switched 'ON', check for voltage supply to the terminal corresponding to terminal 15 of control relay and earth, refer Fig. 6C-157.
2. If not, check for continuity of wiring to terminal. Refer to wiring diagrams in Section 12F of this Supplement. If O.K. proceed to next test.

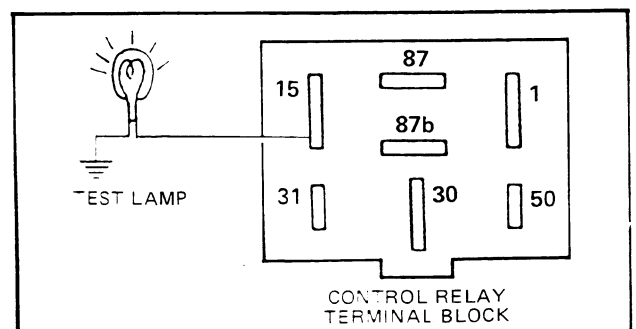

Figure 6C-157

CONTROL RELAY OUTPUT

1. Refit control relay to fuse box.
2. With the engine cranking, check for voltage supply at the fuel pump terminal on the fuel gauge tank unit. Refer Fig. 6C-158.
3. If no voltage reading, check for continuity of wiring from tank unit to the terminal in the fuse box corresponding to terminal 87b of the control relay. If the wiring is O.K. replace control relay and retest.
4. If the wiring and control relays are O.K., and the pump is still not operating, remove fuel gauge tank unit as per service operation 2.6 in Section 12C of this Supplement.
5. Check wiring from terminals on tank unit to fuel pump for continuity. If O.K. remove and replace fuel pump as per operation 2.1 and retest.

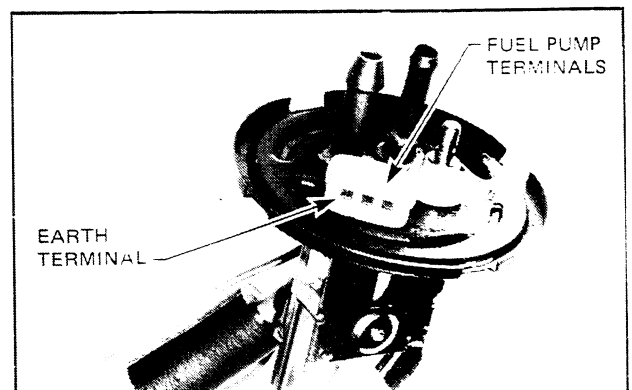

Figure 6C-158

SECTION 6D

ENGINE ELECTRICAL CONTENTS OF THIS SECTION

Subject	Page
CHARGING SYSTEM	6D-1
STARTING SYSTEM	6D-15
IGNITION SYSTEM.....	6D-17

CHARGING SYSTEM

INDEX

Ref.	Subject	Page	Ref.	Subject	Page
1.	GENERAL DESCRIPTION	6D-1		Disassembly.....	6D-6
2.	MINOR SERVICE OPERATIONS	6D-3		Cleaning and Inspection	6D-8
2.1	SAFETY PRECAUTIONS	6D-3		Testing Components.....	6D-8
2.2	MAINTENANCE AND ADJUSTMENTS	6D-3		Diode Assembly	6D-8
	Lubrication.....	6D-3		Stator	6D-8
	Testing the Generator Output and Voltage Regulator	6D-4		Insulation Test for the Stator ..	6D-9
	Testing Generator Output	6D-4		Brushes	6D-9
	Testing the Voltage Regulator Charging Circuit Voltage Drop Test	6D-5		Rotor	6D-9
3.	MAJOR SERVICE OPERATIONS.....	6D-5		Insulation Test for the Rotor Coil.....	6D-10
3.1	GENERATOR.....	6D-5	4.	Reassembly	6D-10
	Remove.....	6D-5	5.	FAULT DIAGNOSIS	6D-12
	Reinstall	6D-5	6.	SPECIFICATIONS	6D-13
				TORQUE WRENCH SPECIFICATIONS.....	6D-13

1. GENERAL DESCRIPTION

The Bosch 45 amp generator carries over from VH to VK Series for the base 3.3 litre Electronic Spark Timing models.

On models fitted with air conditioning or Electronic Fuel Injection, VK Series models have fitted a new Hitachi 60 amp generator.

On models with both air conditioning and Electronic Fuel Injection, a new Hitachi 70 amp generator is fitted.

Service procedures for the Bosch 45 amp generator are as published in Section 08 Generating Systems, Improved Performance L6 and V8 Engine Service Manual No. M38338.

The following Section covers the service procedures for both 60 amp and 70 amp Hitachi generators (Fig. 6D-1). Both models are similar in mechanical construction. Differences in the number of turns and the wire gauge on the respective rotor and stator windings result in the different electrical performance characteristics.

The stator comprises a three phase star connected output winding on a ring shaped lamination pack. The rotor is of 12 pole construction and carries a slip ring fed field winding. The rotor is supported by ball bearings in both drive and slip ring end brackets.

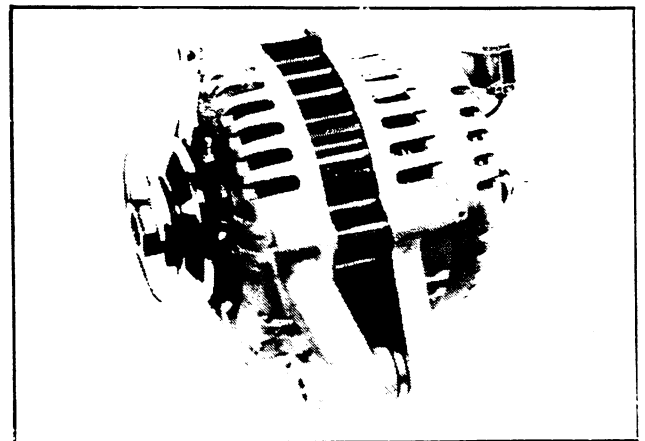

Figure 6D-1

6D-2 ENGINE ELECTRICAL

Rectification of the generator output is achieved by six silicon diodes contained within the slip ring end bracket and connected in a three phase bridge circuit between stator and output terminals. A second rectifier bridge is formed by using three auxiliary low current diodes used in conjunction with three main diodes. This supplies the current for the generator field coil via the brushes, slip rings and voltage regulator (refer Fig. 6D-2).

The generator output is controlled by an electronic voltage regulator unit mounted inside the slip ring end bracket. Design features of the voltage regulator include, temperature compensation, radio frequency interference suppression. The regulator requires no adjustment in service.

The generator has three external connections. The battery positive lead to the 'BAT' terminal, the 'L' terminal for the generator warning light and the 'S' terminal for sensing the output voltage.

The diode and stator windings are cooled by air flow through the generator, induced by two internally mounted ventilating fans, one on each end of the rotor.

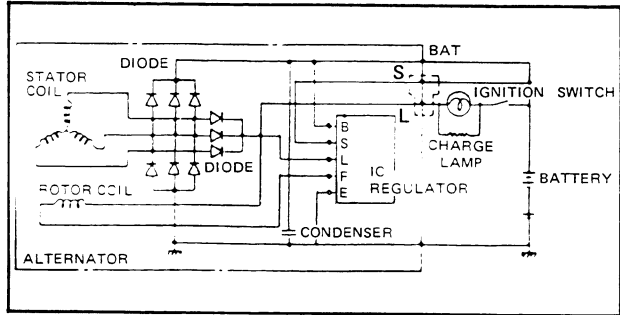

Figure 6D-2

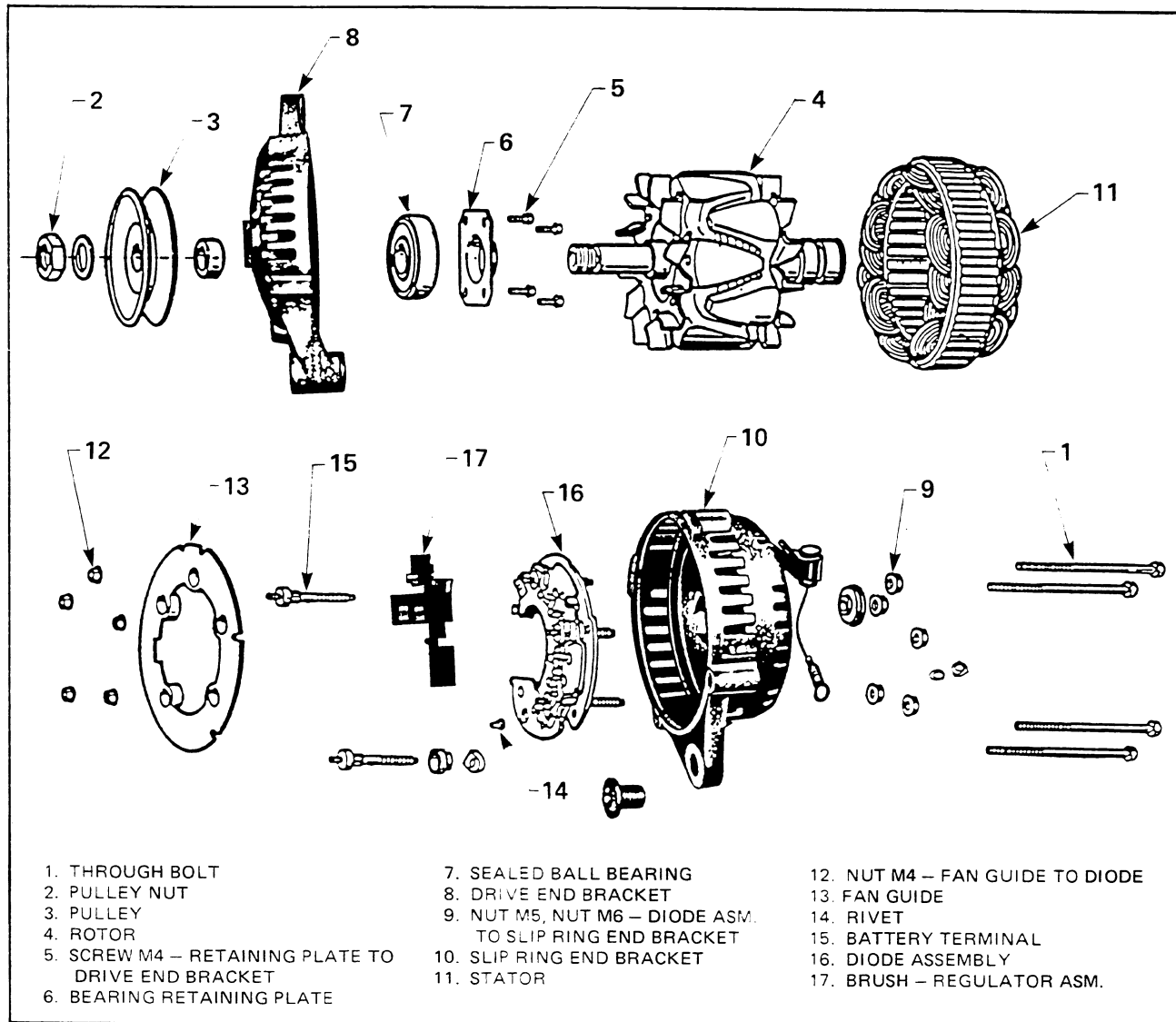

Figure 6D-3

2. MINOR SERVICE OPERATIONS

2.1 SAFETY PRECAUTIONS

Since the generator and voltage regulator are designed for use only on a negative earth system, the following precautions must be observed. Failure to observe these precautions will result in serious damage to the generator.

1. When installing a battery, first fit the positive (+) connector to the battery positive (+) terminal and fit the negative (-) connector to the negative (-) battery terminal.
2. When a slave battery is utilised for starting purposes, ensure the two batteries are connected in parallel, i.e. positive terminals together and negative terminals together.
3. When charging the battery, disconnect the battery negative (-) cable, thus isolating the generator from the battery and external charging equipment.
4. It is recommended that the generator not be operated on open circuit (this is without battery in circuit), and the battery not be disconnected while the generator is running.

If the battery is disconnected when the engine is running, do not operate above idle speed, and for only a limited period.

NOTE: This will enable exchange of batteries, if a slave battery has been used for starting, when jumper leads are not available.

5. The cable connecting the generator and battery is 'live' even when the engine is not running.
6. Do not attempt to polarise the generator.
7. Always ensure that the generator lamp glows when the ignition switch is turned to the 'ON' position.

NOTE: As this circuit is related to and assists in the excitation of the rotor field windings, do not proceed until any faults in the generator light circuit have been rectified. Refer to 4.0 Fault Diagnosis of this Section.

2.2 MAINTENANCE AND ADJUSTMENTS

At regular intervals, inspect the terminals of the generator for corrosion, loose connections and the wiring for frayed insulation. Check the mounting bolts for tightness, check the drive belt for alignment and wear and the drive pulley for damage. Check the drive belt for correct tension as outlined under heading 'Fan Belt Adjustment' in the 'Cooling System' Section 6 of the VH Series Service Manual Supplement No. M38731.

IMPORTANT: Because of the high inertia and speeds of the rotor used in generators, correct belt tensioning is critical.

LUBRICATION

The ball bearings in both end brackets are sealed, therefore cannot be lubricated.

If the bearings are removed during overhaul, it is recommended that they be replaced.

6D-4 ENGINE ELECTRICAL

TESTING THE GENERATOR OUTPUT AND VOLTAGE REGULATOR

Before testing the output, make certain that the generator circuit is thoroughly checked for loose or dirty connections and the fan belt is correctly tensioned. The generator must always be connected to the battery during testing otherwise damage to the diodes could result. The battery should be fully charged. The generator warning light, in addition to indicating that the generator is charging, also carries the current necessary for initial field excitation. The globe used should be 2.2 watt.

Testing Generator Output

1. Disconnect the battery negative terminal.
2. Remove the wire from the 'BAT' terminal on the generator.
3. Using an accurate ammeter having at least an 0-80 scale, connect the positive lead to the generator 'BAT' terminal and the other lead to the disconnected positive wire. Refer Fig. 6D-4.
4. Connect battery lead, fit a loading device across the battery terminals, i.e. an adjustable carbon pile. Refer Fig. 6D-4.

NOTE: Loading device must have a power consumption of 1000 watts minimum.

5. Connect the positive lead of a voltmeter to the 'BAT' terminal on the generator and the negative lead to a good ground on the generator body. Refer Fig. 6D-4.
6. Start the engine and increase the engine speed to approximately 2500 rpm.

Adjust the loading device to achieve a reading of 14 volts on the voltmeter.

The generator output should be over 55 amps for the LR160-706 generator and over 65 amps for the LR170-703 generator, as indicated on the ammeter.

CAUTION: On completion of the above check, release the adjustment of the loading device and reduce the engine speed.

NOTE: If the generator does not provide rated output, it should be disassembled and checked further as outlined in this Section.

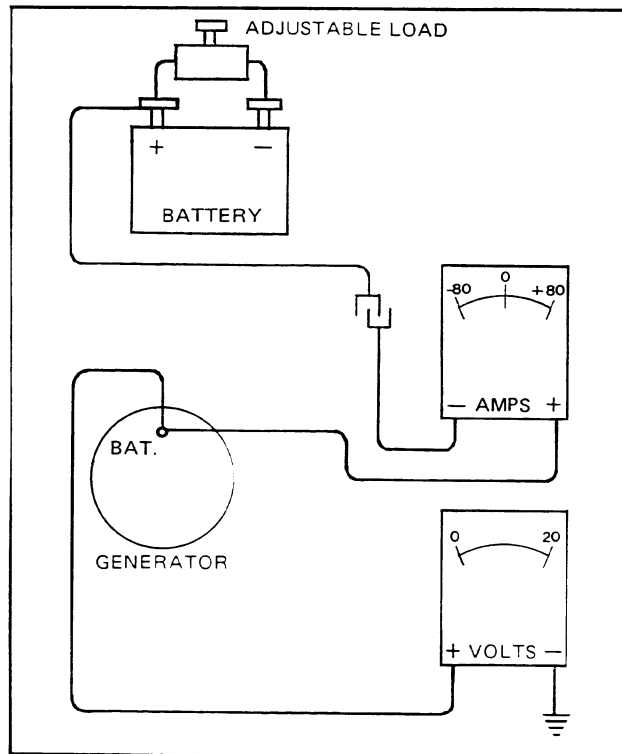

Figure 6D-4

Testing the Voltage Regulator

1. Connect the positive lead of a voltmeter to the positive terminal on the battery and the negative lead to the negative terminal.
2. Place a resistance or test lamp load across the battery and adjust to maintain a current flow of 11 amps or as an alternative, switch on the high beam headlights.

3. Run the engine at approximately 2500 rpm, maintain this engine speed for 15 seconds and check voltage reading. This should be 14.1-14.5 volts.

NOTE: The voltage regulator is a non-adjustable unit and if proved faulty must be replaced with a new unit.

Charging Circuit Voltage Drop Test

With the normal connections made at the generator, the charging circuit can be checked for voltage drop as follows:-

1. Connect a low range voltmeter between the generator positive terminal and the battery positive post.
2. Switch on the headlights, start the engine and increase engine speed to approximately 2500 rpm and note voltmeter reading.
3. Reduce engine speed and transfer the voltmeter connections negative to the generator body and positive to the battery negative post, increase engine speed to approximately 2500 rpm and again note voltmeter reading.
4. If the readings exceed 0.5 volt on the positive side and 0.25 volt on the negative side there is a high resistance in the charging circuit which must be traced and corrected.

3. MAJOR SERVICE OPERATIONS

3.1 GENERATOR

REMOVE

CAUTION: Disconnect the battery ground (negative) cable to prevent accidental short circuits.

1. Remove the wire from the generator output terminal.
2. Remove the connector from the warning light terminal on the generator.
3. Loosen the generator to support bracket bolt. Refer Fig. 6D-5.
4. Remove the generator brace bolt and detach the drive belt from pulley. Refer Fig. 6D-5.
5. Remove generator to support bracket bolt and remove generator from engine. Refer Fig. 6D-5.

REINSTALL

1. Position the generator on the mounting bracket and install the bolt and nut; do not fully tighten nut.
2. Install drive belt to generator drive pulley.
3. Install the generator to brace bolt and washers, finger tight; generator pulley should be aligned with crankshaft and water pump pulleys.
4. Adjust drive belt tension as outlined under the heading 'Drive Belt Adjustment' in the 'Cooling System' Section 6 of the VH Series Service Manual Supplement. Tighten the brace bolt to 20-25 Nm.
5. Tighten the generator to mounting bracket bolt and nut to a torque of 34-44 Nm.
6. Install the connector to the warning light (L) terminal.
7. Connect the red wire to output (BAT) terminal of the generator.
8. Reconnect the battery ground cable.

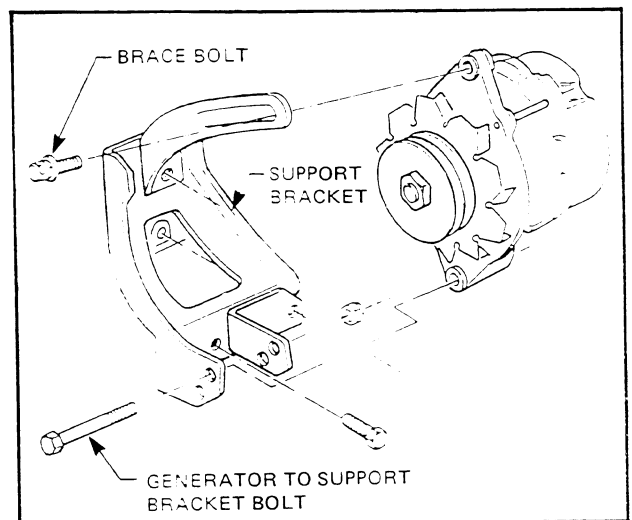

Figure 6D-5

6D-6 ENGINE ELECTRICAL

DISASSEMBLY

1. Mark the relative positions of the slip ring end bracket, stator and drive end bracket.
2. Remove the four through bolts. Refer Fig. 6D-6.
3. Separate and remove the stator and slip end bracket from the rotor and drive end bracket, by inserting two screwdrivers on opposite sides between the drive end bracket and stator core and prise apart.

CAUTION: Care should be exercised so as not to damage the stator coil with the screwdrivers.

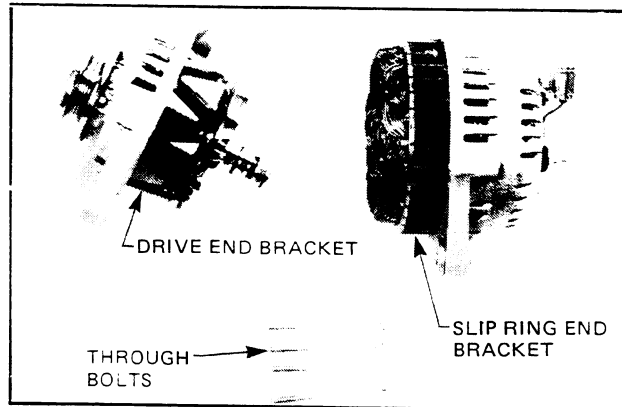

Figure 6D-6

4. Hold the rotor in a vice (using copper jaws) and remove pulley attaching nut with a 22 mm socket. Take care not to damage or bend the blades of the fan.
5. Remove pulley lock washer, pulley and distance collar. Withdraw the rotor from the drive end bracket.

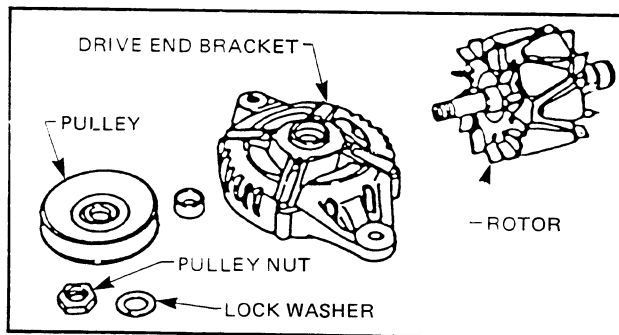

Figure 6D-7

6. Remove the four screws securing the front bearing retaining plate to drive end bracket, remove the retaining plate. Refer Fig. 6D-8.
7. Press the front bearing out from the drive end bracket. Discard bearing.

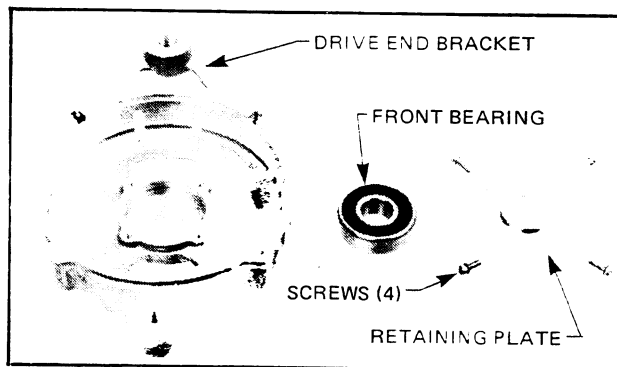

Figure 6D-8

8. Using a suitable puller, remove the slip ring end bracket bearing from the rotor shaft. Refer Fig. 6D-9.

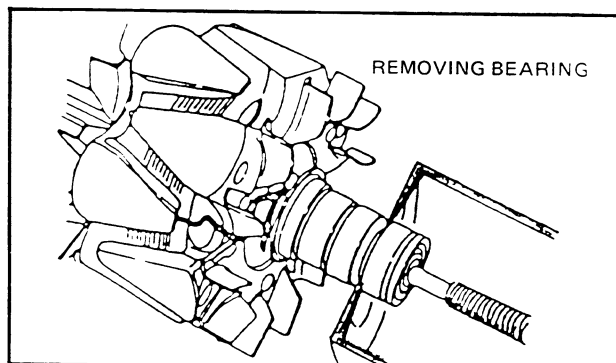

Figure 6D-9

ENGINE ELECTRICAL 6D-7

9. Remove the six slip ring end bracket fixing nuts and remove the slip ring end bracket from the stator and diode assembly. Refer Fig. 6D-10.

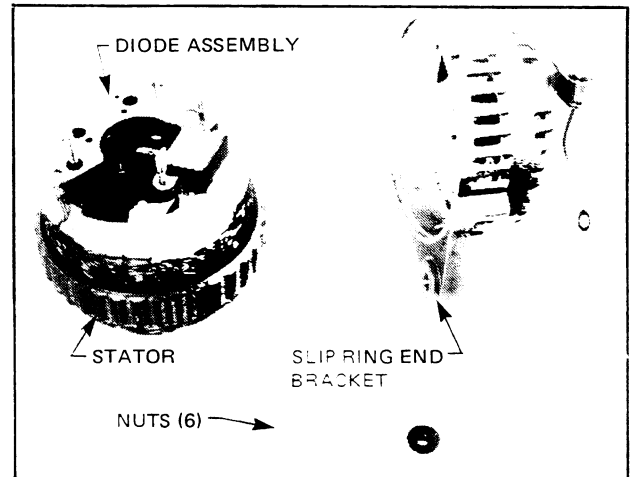

Figure 6D-10

10. Remove the stator coil by unsoldering the three stator winding connections from the diode assembly and separating the diode assembly from the stator winding end points. Refer Fig. 6D-11.

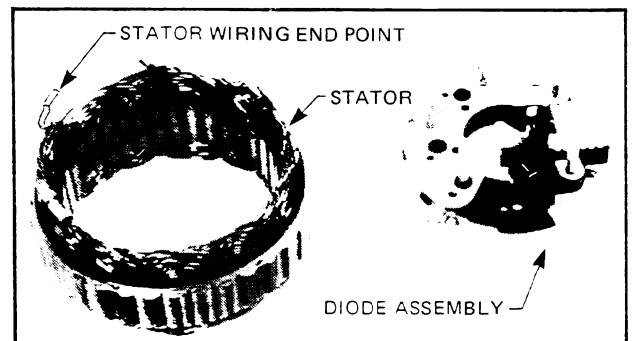

Figure 6D-11

11. Remove the five nuts holding the fan guide to the diode assembly. Refer Fig. 6D-12.

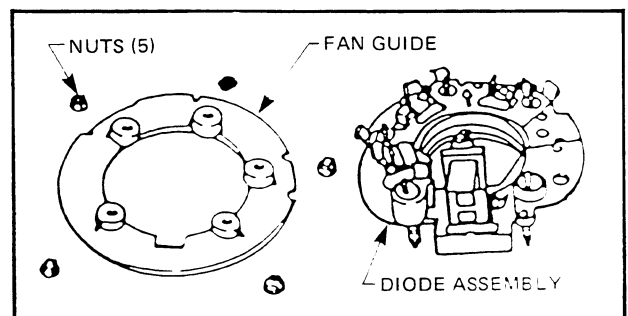

Figure 6D-12

12. To remove the brush and regulator assembly from the diode assembly, remove the rivet by filing away peened end. Once the rivet is removed, remove the battery terminal and the diode and brush regulator assemblies can be separated.

NOTE: Never remove the rivet except when replacing diodes or the brush assembly.

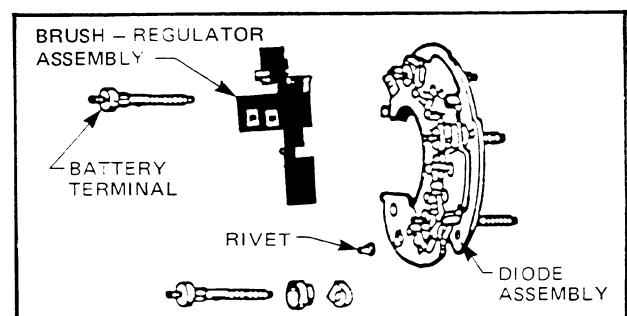

Figure 6D-13

6D-8 ENGINE ELECTRICAL

CLEANING AND INSPECTION

With generator completely dismantled, the components should be cleaned and inspected.

1. Wash all metal parts except stator and rotor assemblies in cleaning solvent.
2. Blow off any dust or foreign matter from the rotor and stator assemblies with compressed air.

CAUTION: On no account should the rotor or stator windings be cleaned in any degreasing compound, since this might damage the insulation to the extent that a short circuit or ground could subsequently develop.

3. Inspect the slip rings, clean off foreign matter with cleaning solvent.

TESTING COMPONENTS

Diode Assembly

Test of diode conductivity.

The current flows in one direction only in each diode. It should flow down from the positive side diode (at the top of the assembly) in the direction of the arrows refer Fig. 6D-14.

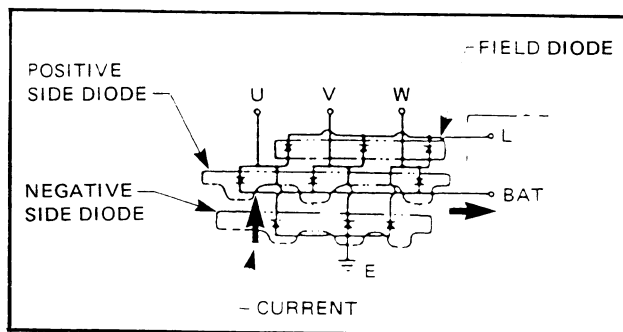

Figure 6D-14

Using a 1.5 watt test lamp and a 12 volt battery connect to each diode in turn to check conductivity refer Fig. 6D-15.

Connect one lead to the diode stem and the other lead to the diode base plate. Reverse the leads, the bulb should light in one direction only. Check all positive and negative diodes.

If any diode shows current flow in both direction or not at all, replace the diode assembly.

To test the field diodes, located on top of the assembly, place the test lamp and battery lead at end of the diode. Check that the bulb lights in one direction only. Check all three field diodes.

If any diode proves faulty, replace diode assembly.

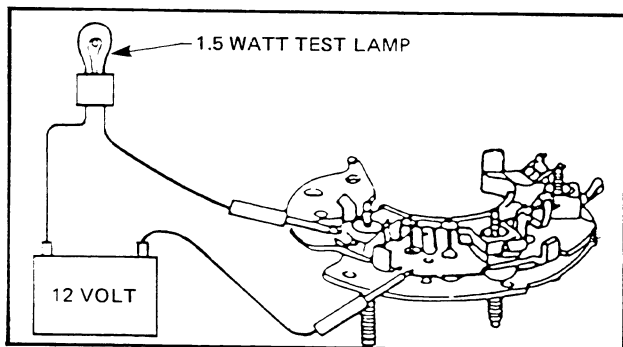

Figure 6D-15

Stator

Open circuit test for the stator windings.

The continuity of the stator windings has to be checked, by first connecting any two of the three stator leads in series with an ohm meter. Refer Fig. 6D-16.

Repeat the test by checking at the third lead.

If continuity is found in all windings the stator can be considered to be normal.

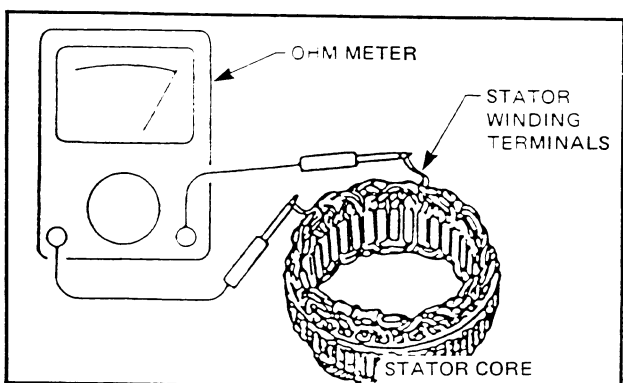

Figure 6D-16

Insulation Test for the Stator

Using an ohm meter, connect the test leads to the stator core and to one of the winding terminals. Refer Fig. 6D-17.

If continuity is found, the stator is considered faulty and must be replaced.

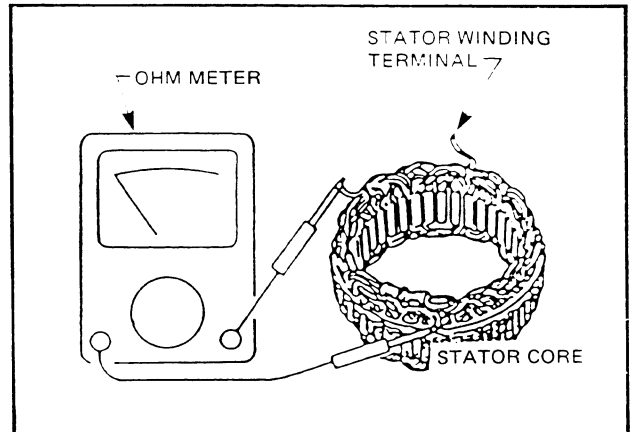

Figure 6D-17

Brushes

Measurement of brush length:

If the 'free-standing' brush length is found to be less than 2 mm from the brush holder, then replace the brush holder assembly.

This minimum acceptable length is marked on the brush with a shallow indentation. Refer Fig. 6D-18.

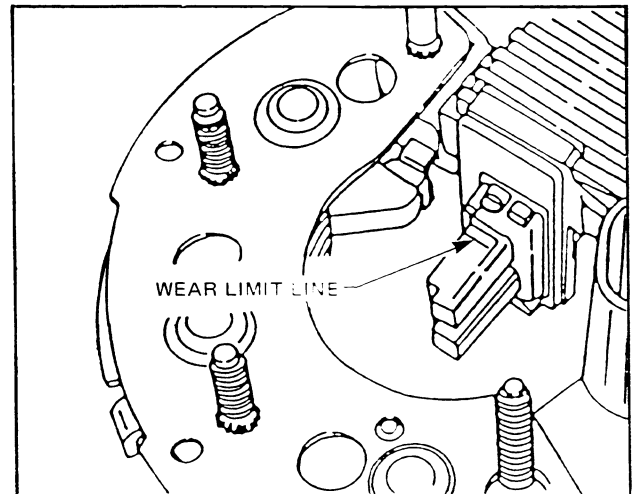

Figure 6D-18

Rotor

Open circuit test for rotor coil:

Using an ohm meter check for continuity between the slip rings. Refer Fig. 6D-19.

If continuity is found, the rotor coil can be considered to be normal.

On the contrary, if no continuity is found, the rotor coil is considered to be defective and should be replaced.

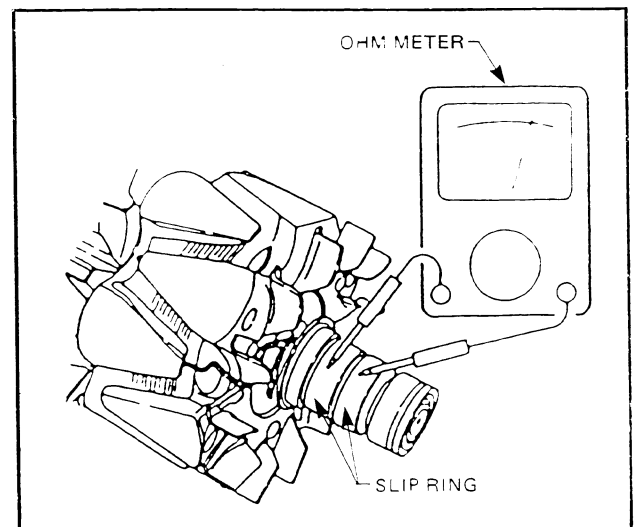

Figure 6D-19

6D-10 ENGINE ELECTRICAL

Insulation Test for the Rotor Coil

Using an ohmmeter, check the insulation between the two slip rings and the rotor core or shaft. Refer Fig. 6D-20.

If no continuity is found, the rotor coil can be considered to be normal.

If continuity is found, the rotor coil is considered to be shorted and it must be replaced.

The slip rings should be checked for wear or damage and polished with fine glass paper until smooth, or replaced if badly worn or damaged.

If necessary, the slip rings may be skimmed down on a lathe to a minimum diameter of 21.6 mm.

If the outside diameter of the slip rings is found to be less than 21.6 mm, the rotor must be replaced.

NOTE: No attempt should be made to straighten a bent rotor shaft.

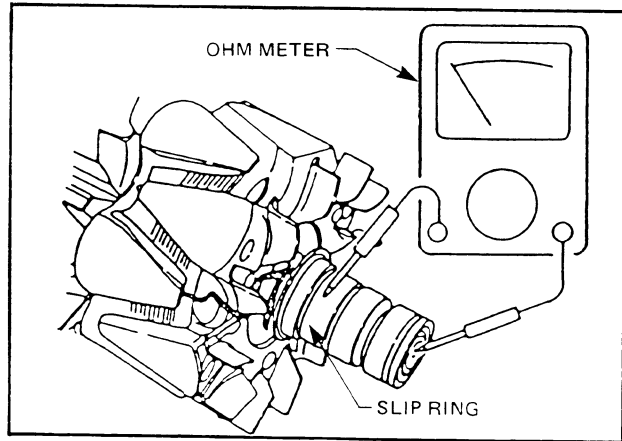

Figure 6D-20

REASSEMBLY

The reassembly of the generator is the reversal of the disassembly procedure, with consideration given to the following:

1. Tightening torques (refer Torque Wrench Specifications at the end of this Section).
2. Reassembly of the slip ring end bracket and the drive end bracket.
 - a. Holding the rotor, note the thin semi circular band located in the groove of the slip ring bearing outer circumference. Refer Fig. 6D-21.

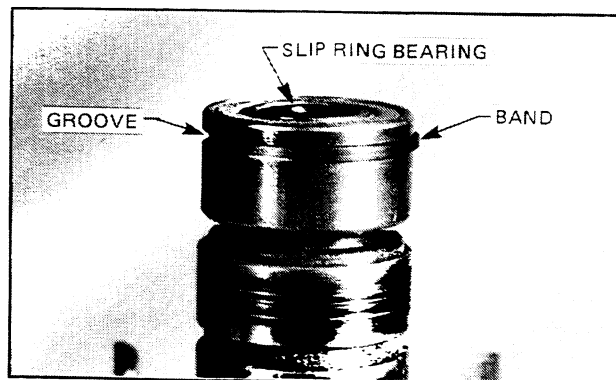

Figure 6D-21

- b. By pushing on the pinched portion of the band, rotate the band to a position of least exposure (the deepest section of the bearing groove). Refer Fig. 6D-22.



Figure 6D-22

3. Insert a pin into the small hole near the outside centre of the slip ring end bracket. Refer Fig. 6D-23.

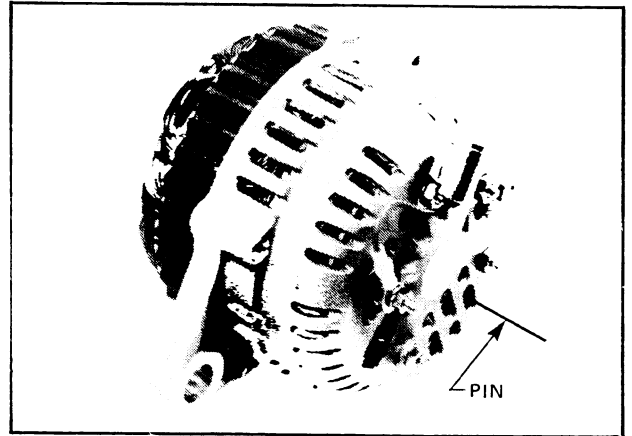

Figure 6D-23

- Use the pin to hold the brushes back into the brush holder. Refer Fig. 6D-24.
4. Assemble the generator by offering drive end bracket and rotor assembly to the stator and slip ring end bracket assembly, aligning the marks made during disassembly.
 5. Fit and tighten the four through bolts evenly to the torque specified at the end of this Section. Ensure the end brackets are sitting evenly on the stator. Use the lower mounting bolt, or an equal size rod through lower mounting holes in the drive end and slip ring end brackets, to ensure the holes are aligned.
 6. Slowly withdraw the pin used in step 3.

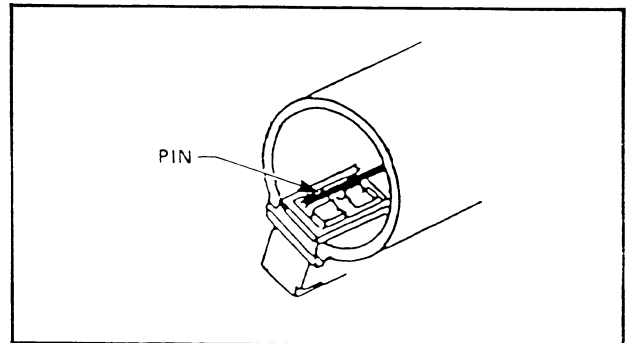

Figure 6D-24

6D-12 ENGINE ELECTRICAL

4. FAULT DIAGNOSIS

Before conducting any generator test, ensure that:

1. Battery is fully charged.
2. Generator drive belt is correctly tensioned. Refer Fig. 6D-25.
3. Generator mounting bolts and brackets are secure.
4. Check battery terminals and check for loose or corroded connections to generator.

TENSION			
NEW		USED	
lbs.	kg.	lbs.	kg.
90	41	55	25

Any belt that has been run for more than 10 minutes is to be considered used.

Figure 6D-25

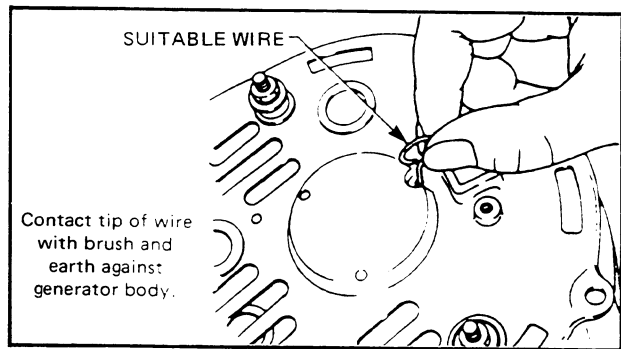
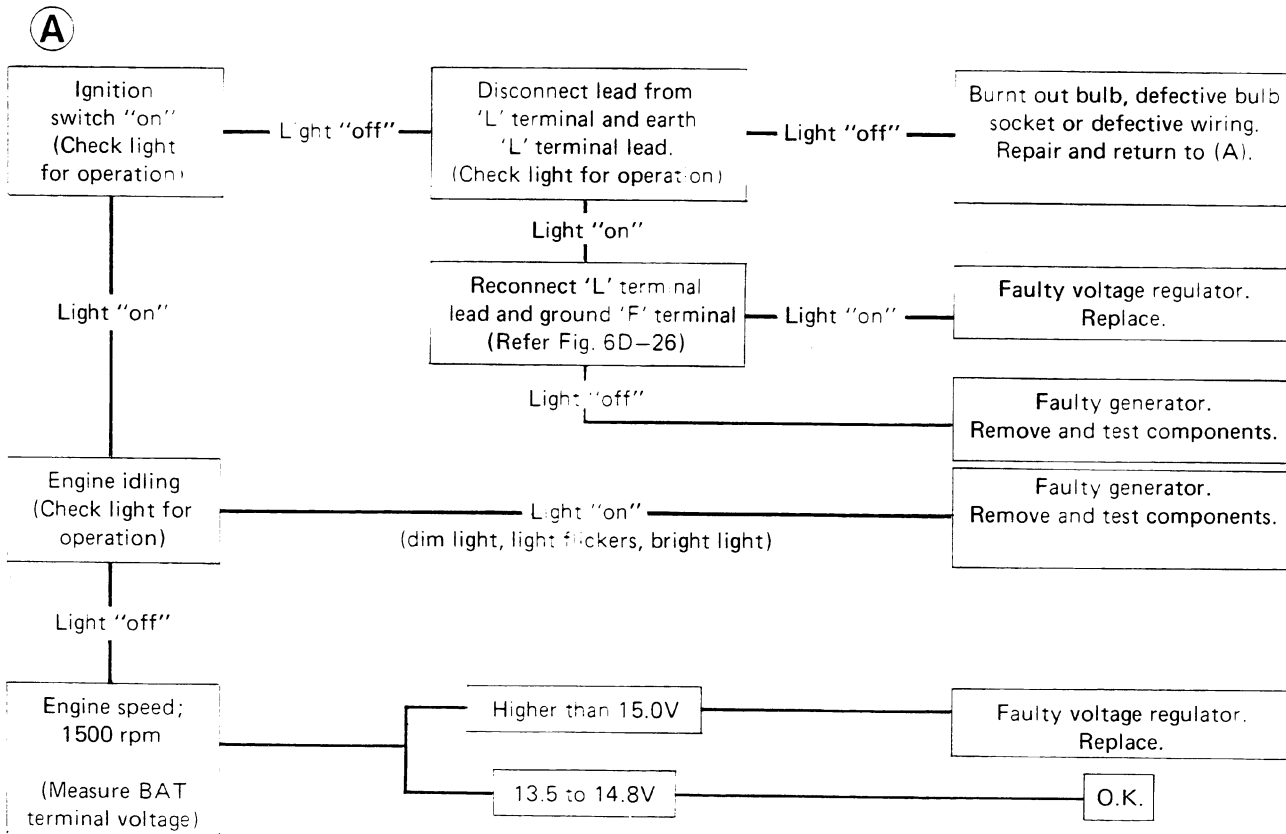

Figure 6D-26



- | | |
|---|---|
| <p>1. UNDERCHARGED BATTERY</p> <ul style="list-style-type: none"> a. Loose drive belt. b. Defective battery. c. Loose connection in charging circuit. d. Corroded connections in charging circuit. e. Defective wiring. f. Faulty generator. g. Faulty voltage regulator. <p>2. OVERCHARGED BATTERY</p> <ul style="list-style-type: none"> a. Shorted battery cell. b. Faulty voltage regulator. c. Short circuit in rotor winding. | <p>3. NOISY GENERATOR OPERATION</p> <ul style="list-style-type: none"> a. Normal magnetic hum. b. Badly discharged battery. c. Generator mounting brackets and/or bolts loose. d. Worn or frayed drive belt. e. Worn or damaged drive pulley. f. Worn bearings. g. Loose drive belt. h. Loose drive pulley attaching nut. i. Open or shorted main diodes. j. Open or shorted stator windings. |
|---|---|

5. SPECIFICATIONS

GENERATOR:

	LR160 – 706	LR170 – 703
Type	Negative	Negative
Earth Polarity	12 volts	12 volts
Nominal Voltage	60 amps	70 amps
Nominal Output at 6000 generator rpm	Approx 14.2 – 14.6 volts	Approx 14.2 – 14.6 volts
Regulated Output Voltage @ 20°C	3	3
Stator Phases	Star	Star
Stator Winding Connections	12	12
Number of Poles		

6. TORQUE WRENCH SPECIFICATIONS

	Nm
Through Bolts	3.14 – 3.92
Pulley Nut	39.20 – 58.80
Front Bearing Retaining Plate Screws	1.67 – 2.35
Fan Guide to Diode Assembly Nuts	1.67 – 2.35
Slip Ring End Bracket M6 Nuts	5.88 – 7.84
Slip Ring End Bracket M5 Nuts	3.14 – 3.92
Generator Brace Bolt	20.00 – 25.00
Generator to Bracket Bolt and Nut	34.00 – 44.00

STARTING SYSTEM

INDEX

Ref.	Subject	Page	Ref.	Subject	Page
1.	GENERAL DESCRIPTION	6D-15	2.1	STARTER MOTOR (EFI)	6D-15
2.	SERVICE OPERATIONS	6D-15		Remove	6D-15
				Reinstall	6D-15

1. GENERAL DESCRIPTION

The starter motors used on 3.3 litre and 5.0 litre VK Series models carry over from VH Series models, except

that the 3.3 litre starter motor now incorporates a plastic shifter fork (similar to JB Camira).

2. SERVICE OPERATIONS

The service operations for these starter motors are as described in the Improved Performance L6 and V8 Engine Service Manual, Part No. M38338, Section 07 Starter Motor Removal and Installation operations for 3.3

EST and 5.0 Litre engines, carryover from VH Series. However, revised procedures are required for 3.3 EFI engines.

2.1 STARTER MOTOR (EFI)

REMOVE

1. Disconnect battery earth lead.
2. Remove battery feed wire and starter motor solenoid wire from the terminals on the solenoid.
3. Remove top starter motor mounting bolt.
4. Loosen bottom starter motor mounting bolt. With left hand supporting the rear of the starter motor, remove the bottom mounting bolt with the right hand.
5. Remove the starter motor from its position and move it along between the exhaust extractors and the bottom of the passenger side suspension strut tower.
6. Pull the starter motor up out between Nos. 2 and 3 inlet manifold branches (refer Fig. 6D-27).

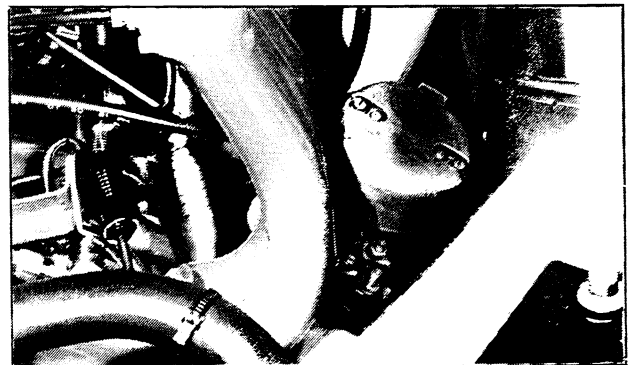

Figure 6D-27

REINSTALL

Installation is the reversal of removal procedures. Tighten starter motor mounting bolts to 20 - 28 Nm torque.

IGNITION SYSTEMS

INDEX

Ref.	Subject	Page	Ref.	Subject	Page
1.	GENERAL INFORMATION	6D-17	2.5	ELECTRONIC CONTROL MODULE	6D-27
1.1	ELECTRONIC SPARK TIMING	6D-18		Remove.....	6D-27
	General Description.....	6D-18		Reinstall	6D-27
1.2	SYSTEM LAYOUT	6D-18	2.6	COOLANT TEMPERATURE SENSOR	6D-28
1.3	ELECTRONIC SPARK TIMING SYSTEM			Remove.....	6D-28
	COMPONENTS	6D-19		Test	6D-28
	Control Module.....	6D-19		Reinstall	6D-28
	Engine Speed Sensor	6D-19	2.7	THROTTLE POSITION SWITCH	6D-28
	Manifold Vacuum Sensor.....	6D-20		Remove.....	6D-28
	Engine Coolant Temperature			Reinstall	6D-28
	Sensor.....	6D-20		Adjustment.....	6D-29
	Throttle Position Switch.....	6D-20	2.8	ENGINE SPEED SENSOR	6D-30
	Starter Motor.....	6D-20		Test	6D-30
	Air Conditioning Compressor			Remove.....	6D-30
	Clutch	6D-20		Reinstall	6D-30
	Ignition Coil	6D-21	3.	DIAGNOSIS	6D-31
1.4	MODES OF OPERATION	6D-21	3.1	DIAGNOSIS LIMP LAMP	6D-31
	Cranking	6D-21	3.2	DIAGNOSTIC ELECTRICAL	
	Idle	6D-21		CONNECTION FOR EST	6D-31
	Normal Mode.....	6D-22	3.3	DIAGNOSIS OF LIMP LAMP OPERATION	6D-32
	Overspeed Control	6D-23		Limp Home Mode.....	6D-32
	Decelerating	6D-23		Possible Temperature Sensor	
	Limp Home Mode.....	6D-23		Fault.....	6D-32
2.	SERVICE OPERATIONS	6D-24		Possible Vacuum Sensor or	
2.1	SERVICE NOTES	6D-24		Throttle Position Switch Fault (1)	6D-32
2.2	SETTING IGNITION TIMING	6D-24		Possible Vacuum Sensor or	
2.3	DISTRIBUTOR	6D-24		Throttle Position Switch Fault (2)	6D-33
	Remove.....	6D-24	3.4	WIRING HARNESS CHECKING	
	Reinstall	6D-25		PROCEDURE	6D-38
	Disassembly.....	6D-26	4.	SPECIFICATIONS	6D-40
	Reassembly	6D-26	5.	TORQUE WRENCH SPECIFICATIONS	6D-41
2.4	MANIFOLD VACUUM SENSOR	6D-26	6.	SPECIAL TOOLS	6D-41
	Remove.....	6D-26			
	Reinstall	6D-26			
	Testing	6D-27			

1. GENERAL INFORMATION

The ignition system employed on 3.3 litre Electronic Fuel Injected VK Series models is similar to the system used on 3.3 litre VH. Revisions have been made to the distributor advance mechanism and spark plugs have a revised heat range. Refer to Specifications at the end of this Section for details.

The ignition system for 5.0 litre VK Series models carries over from VH.

On SL and Berlina models with the base 3.3 litre engine, a Bosch Electronic Spark Timing system is used instead of the conventional ignition advance system.

6D-18 ENGINE ELECTRICAL

1.1 ELECTRONIC SPARK TIMING

GENERAL DESCRIPTION

The Electronic Spark Timing (EST) system replaces the timing function of the distributor (conventional vacuum and centrifugal advance mechanisms are not used).

The EST system accurately matches the ignition timing to the engine requirements at all speeds and loads.

The EST system processes the input from six sources. These are crankshaft position, coolant temperature, inlet manifold vacuum, throttle position, starter motor and, if fitted, air conditioning load is sensed from the cycling of the compressor clutch.

An electronic micro processor control module controls coil primary current and therefore the generation of the secondary voltage to fire the spark plugs.

Distributors used in the EST system are a simplified version of those used in past High Energy Ignition systems. Having no mechanical or vacuum advance mechanism, the EST distributor simply switches high tension voltage to the appropriate spark plug.

1.2 SYSTEM LAYOUT

Figure 6D-28 shows sensors used by the Control Module to monitor engine operation. The only output from the module, controls coil primary current.

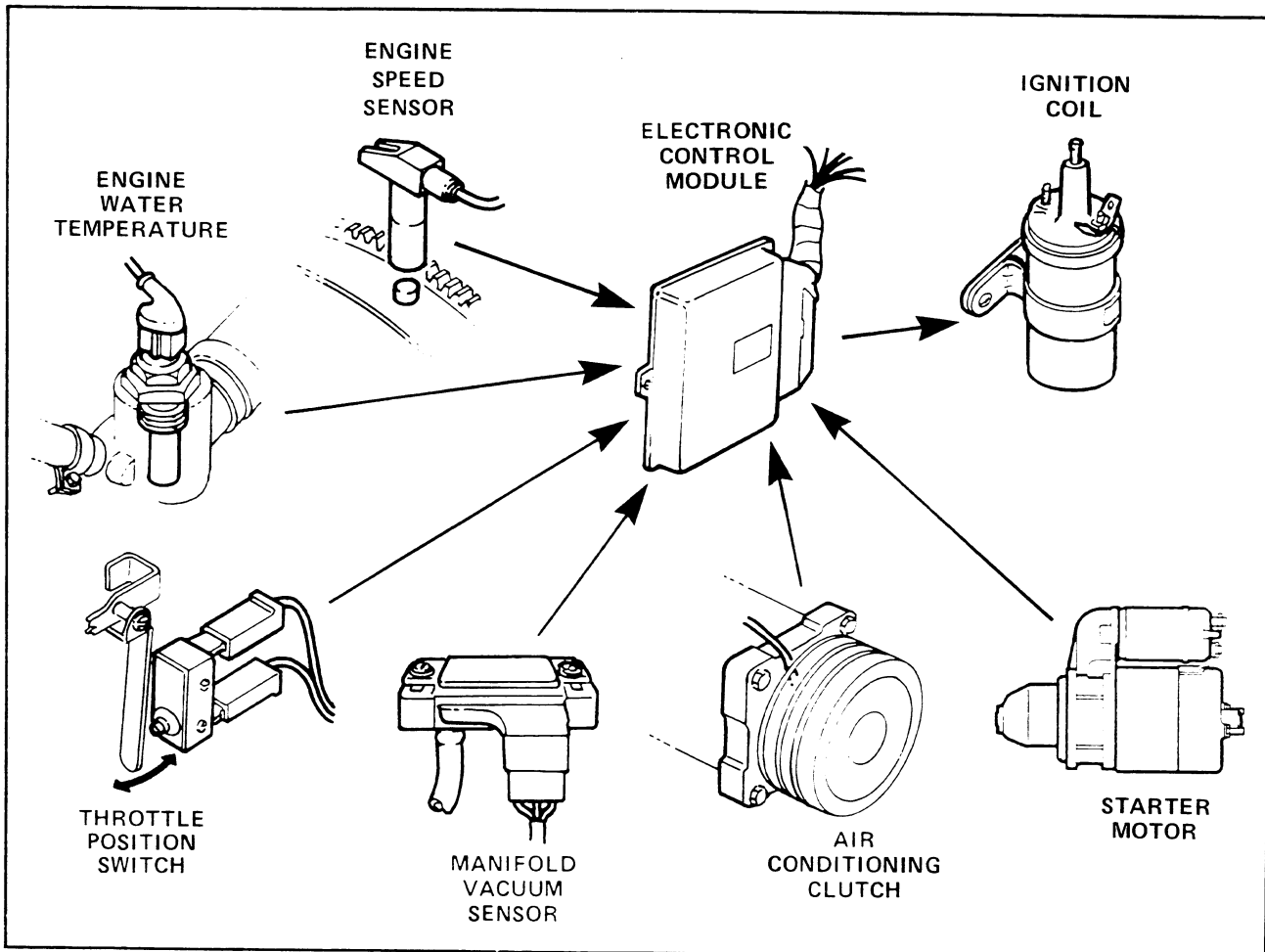

Figure 6D-28

1.3 ELECTRONIC SPARK TIMING SYSTEM COMPONENTS

CONTROL MODULE

The micro processor based control module is located behind the left hand side cowl panel trim. Refer Fig. 6D-29.

The control module performs the following functions:

1. A memory is used to store the micro processor programme and data tables for spark advance as a function of speed and load, temperature, throttle switch position and time after start.
2. The micro processor executes the programme contained in the memory.
3. The spark timing signals from the micro processor are converted into signals to control coil primary current.

For every combination of engine speed and engine load there is a unique spark advance value specified and stored in the control module.

The spark advance information is stored in a memory table. Each entry of this table may be specified independently of any other point.

The electronic control module memory contains two tables.

1. Optimum advance table - for highway use.
2. Modified advance table - for low emission requirements.

The memory tables are used by the micro processor for every ignition pulse calculation.

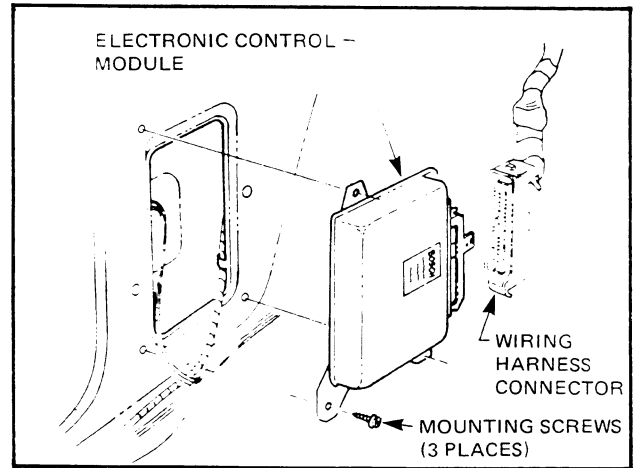

Figure 6D-29

ENGINE SPEED SENSOR

An electronic speed sensor, inductive magnetic pick up type, is mounted on the rear of the cylinder block. Refer Fig. 6D-30.

Three mild steel timing pins spaced 120° apart, are located around the circumference of the flywheel or torque converter assembly, and the pick-up of the speed sensor extends through a hole in the clutch or converter housing.

As each pin passes the sensor, a signal is generated which is sent to the control module. The pins pass the sensor at six degrees before top dead centre.

The time interval between any two pins passing the sensor pick-up, allows the control module to calculate engine speed.

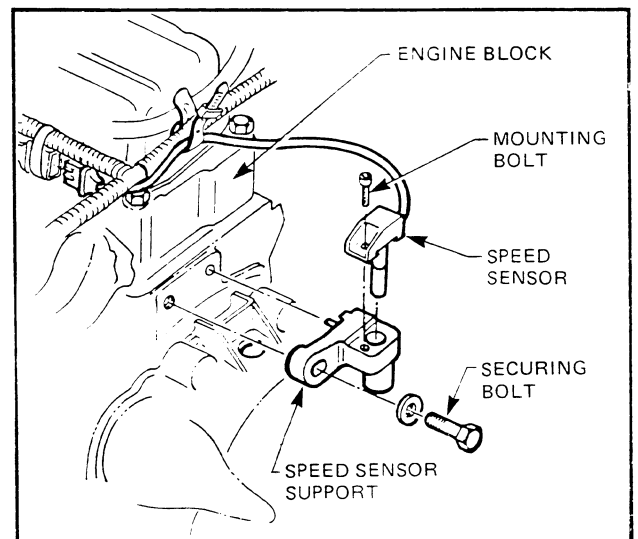

Figure 6D-30

6D-20 ENGINE ELECTRICAL

MANIFOLD VACUUM SENSOR

Mounted on the outside of the fuse box, the engine vacuum sensor relays information to the control module regarding the engine's load condition. Refer Fig. 6D-31.

The manifold vacuum sensor senses engine vacuum and from an input voltage of 5 volts from the control module, a variable output voltage is sent from the sensor to the control module to inform it of the engine's load conditions.

NOTE: Never apply battery voltage to the sensor terminals, as permanent damage can occur.

The sensor is non-repairable, if proved faulty, it must be replaced.

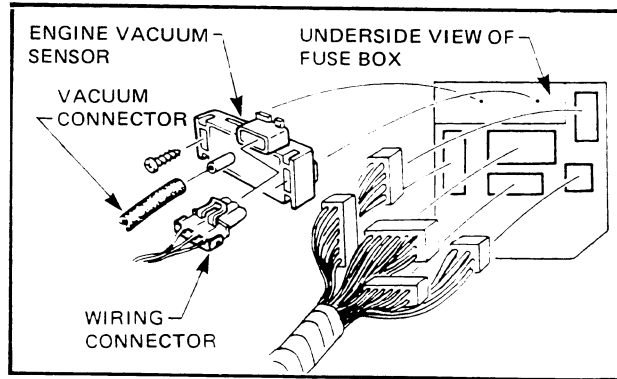

Figure 6D-31

ENGINE COOLANT TEMPERATURE SENSOR

The coolant temperature sensor is mounted on top of the engine thermostat housing. The coolant temperature sensor determines the use of the appropriate advance table during cold starts, normal operation and high temperature operation.

The temperature sensor (Fig. 6D-32) is of the negative temperature coefficient design (NTC). The resistance of the sensor decreases as the engine temperature increases, this causes a decrease in the signal voltage being fed into the control module.

NOTE: The coolant temperature sensor for EST is the same sensor as used for Electronic Fuel Injection.

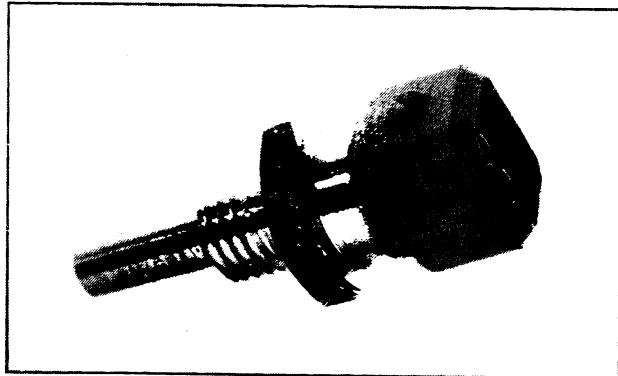

Figure 6D-32

THROTTLE POSITION SWITCH

The throttle position switch is mounted on the carburettor float bowl. Refer Fig. 6D-33. The function of the throttle position switch is to inform the electronic control module when the throttle is closed (idle position).

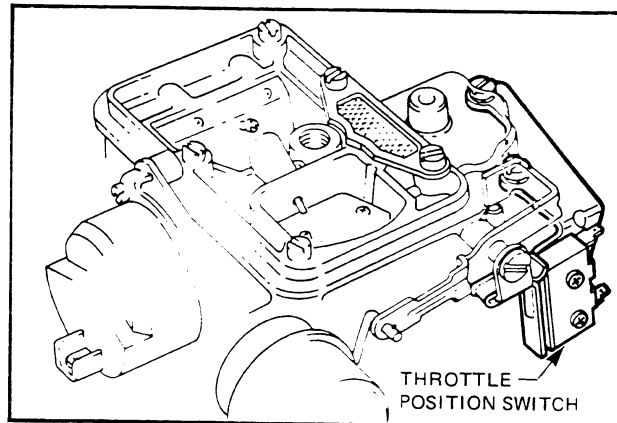

Figure 6D-33

STARTER MOTOR

A signal from the starter motor solenoid informs the electronic control module when the engine is being cranked.

AIR CONDITIONING COMPRESSOR CLUTCH

A signal from the compressor clutch, indicates to the electronic control module when the air conditioner compressor is operating. This results in an increased ignition advance at idle, thereby increasing the idle speed to prevent the engine from stalling or overheating.

IGNITION COIL

The ignition coil used with the EST system is the standard High Energy Ignition coil. Coil triggering is fully controlled from the electronic control module, including dwell time. The electronic control module takes into account battery voltage to adjust the dwell to compensate for the time required for the coil to reach full current level at various supply voltages.

1.4 MODES OF OPERATION

With the many varied conditions under which the engine is required to operate, the ignition system must cater for a number of different operational modes. In addition, compensation factors in ignition performance are required to allow for changes in engine temperature and load conditions, to ensure optimum engine performance with minimum emissions.

For convenience, engine operation can be considered to have six operation modes.

CRANKING

The timing pins situated around the flywheel or torque converter circumference are positioned at 6° BTDC. As the flywheel or torque converter assembly is rotated by the starter motor, the engine speed sensor signals the electronic control module to trigger the ignition coil and firing occurs at 6° BTDC. With a cranking speed less than 400 rpm, the timing will remain at 6° BTDC.

IDLE

With electronic spark timing, idle is defined as follows:

1. Engine speed between 400 and 900 rpm.
2. Throttle position switch closed.

There are a number of functions which operate at idle to maintain idle quality, compensate for loads and maintain idle speed and quality after a cold start.

Idle advance without compensation functions is six degrees BTDC. This is retarded from the optimum advance for emission control. Compensation functions operate to increase advance and maintain idle speed and quality.

Idle - Low Temperature Compensation

To maintain idle speed and quality after a cold start, spark advance is increased. The amount the advance is increased is a function of engine coolant temperature at 'Engine Start' and time since 'Engine Start'. This function is shown in Fig. 6D-34.

Fig. 6D-34 shows additional advance as a function of coolant temperature at 'Engine Start' and time since 'Engine Start'. If 'Engine Start' coolant temperature is A, then additional advance B is available for 12 minutes, provided engine is idling. If engine speed exceeds 900 rpm due to additional advance, advance slowly decreases to effectively govern engine to 900 rpm.

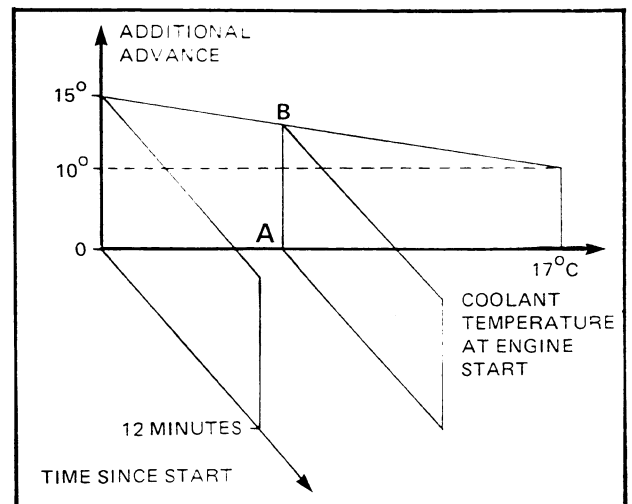

Figure 6D-34

6D-22 ENGINE ELECTRICAL

Idle - High Temperature Compensation

If the engine coolant temperature exceeds 95°C, while the engine is at idle, the spark advance is increased to improve idle quality and increase idle speed for improved cooling. See Fig. 6D-35.

If coolant temperature exceeds 95°C, spark advance is increased up to a maximum of 24° BTDC at 105°C. Idle advance will not exceed 24° BTDC under any circumstances.

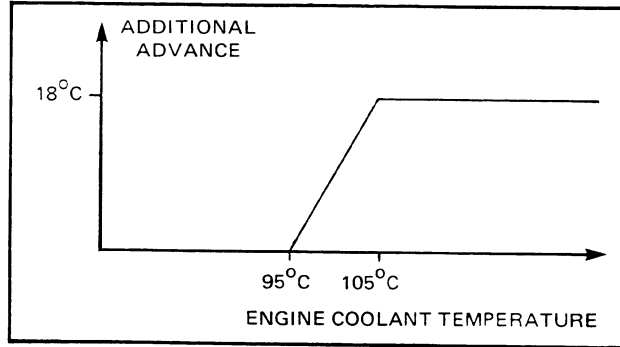

Figure 6D-35

Idle - Load Compensation

The ignition system has the capability to control idle speed to compensate for loads imposed by engine driven accessories.

Air Conditioning Clutch Load

When the engine is at idle and the air conditioning clutch is engaged, the advance is increased by 12° to maintain an idle speed of approximately 850 rpm.

Engine Load

If the engine slows due to high loads such as generator charging and power steering, advance is increased as shown in Fig. 6D-36.

As engine speed falls below speed A, advance increases to a maximum at speed B.

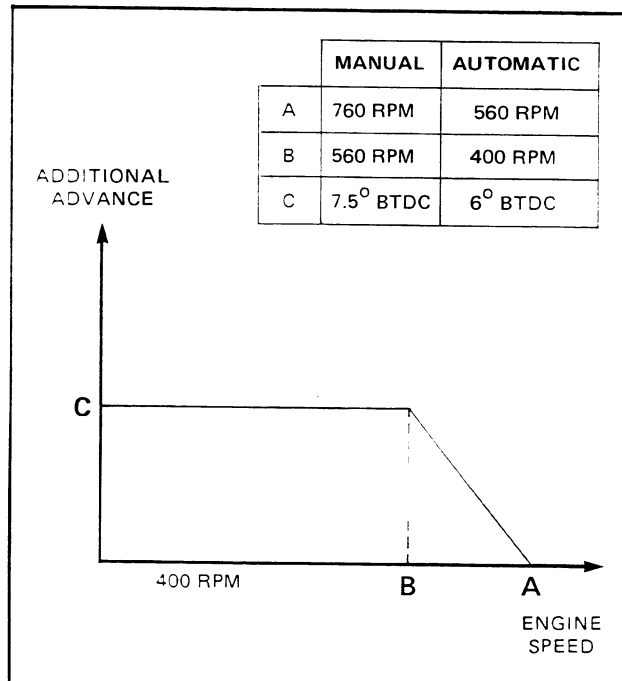

Figure 6D-36

NORMAL MODE

Under normal vehicle operations, the control module optimizes spark advance for improved fuel economy and driveability. The control module also takes into account the necessity for meeting legislated emission levels. Normal mode is defined as engine speed above 900 rpm and throttle position switch OPEN.

Normal Mode - Low Temperature Compensation

After a cold start, advance is increased during normal mode operation to improve cold driveability. The amount of advance selected is based on engine coolant temperature at 'Ignition ON', and is gradually reduced with elapsed time after 'Start'. Refer Fig. 6D-37.

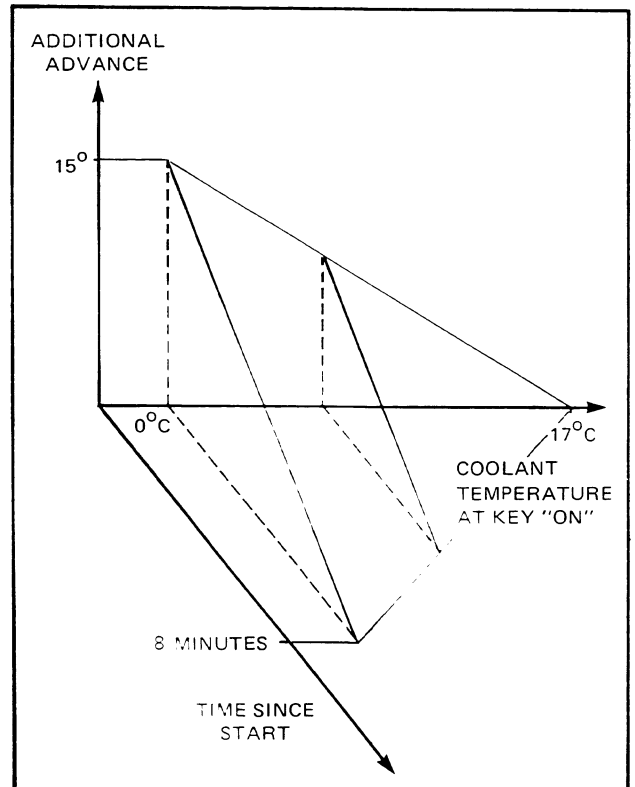

Figure 6D-37

OVERSPEED CONTROL

When the engine speed exceeds 5800 rpm the control module reduces the spark advance to 20° BTDC to avoid engine over speeding.

DECELERATING

When the throttle is released, the engine speed is greater than 900 rpm and the throttle position switch is closed, the operation is defined as decelerating mode.

The control module receives information that the vehicle is in the decelerating mode, and advance is selected by the control module to reduce emissions under decelerating conditions.

LIMP HOME MODE

During normal operation above 400 rpm, the micro processor in the control module calculates the required spark advance for each timing impulse. If the micro processor is unable to operate normally (due to mechanical damage for example) the system reverts to the Limp Home Mode. In this condition all firing impulses are at 6CBTDC. If the limp mode is initiated, the diagnostic lamp on the warning lamp panel (Fig. 6D-38) is lit continuously in the normal driving mode.

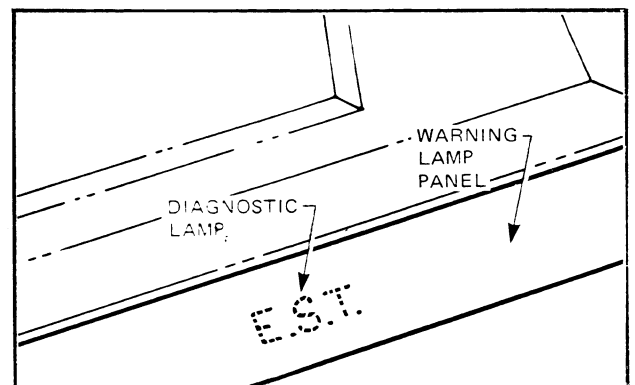

Figure 6D-38

6D-24 ENGINE ELECTRICAL

2. SERVICE OPERATIONS

2.1 SERVICE NOTES

The following requirements must be observed when working on vehicles with the Electronic Spark Timing (EST) system.

1. Before removing any EST system component, disconnect the battery earth lead. Failure to do so could result in the service operator receiving an electrical shock.
2. Never start the engine without the battery being solidly connected.
3. Do not use a quick charge unit to start the engine.
4. Never separate the battery from the on board electrical system while the engine is running.
5. When charging the battery, disconnect it from the vehicle's electrical system.
6. Never subject the Electronic Control Module to temperatures above 80°C (176°F) i.e. paint oven. Always remove control module first if this temperature is to be exceeded.
7. Ensure that all cable harness plugs are connected solidly and that battery terminals are thoroughly clean.
8. Never connect or disconnect cable harness plug at the control module when the ignition is switched on.
9. Before attempting any electric arc welding on the vehicle, disconnect the battery leads and the control module connector.
10. When steam cleaning engines, do not direct the steam cleaning nozzle at any EST component. If this happens, corrosion of the terminals can take place.
11. Do not rotate distributor from standard setting as crossfiring will occur.

2.2 SETTING IGNITION TIMING

Since the ignition timing in the EST system is electronically controlled, the distributor position has no effect on the engine ignition timing setting.

The only requirement for distributor setting is that the rotor button must be aligned with the appropriate segments in the distributor cap to fire the spark plugs.

To set distributor, loosen distributor clamp bolt and carry out steps 4 and 5, as described in 2.2 Distributor - Reinstall.

2.3 DISTRIBUTOR

REMOVE

1. Unfasten spring clips holding distributor cap and remove distributor cap.
2. Crank the engine until the distributor rotor is in position to fire No. 1 cylinder and the timing mark on the torsional damper is in alignment with the longest mark (TDC) on the front cover timing scale. Fig. 6D-39 shows the No. 1 firing position for EST engines with the mark on the rotor lined up with the notched mark in the distributor housing.

NOTE: The longest mark on the timing scale on the front cover is top dead centre number 1 cylinder.

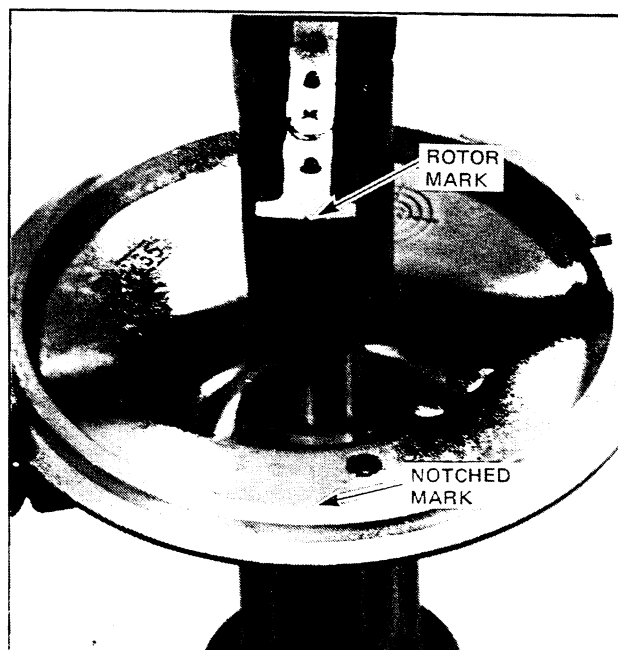

Figure 6D-39

3. Clean all foreign matter from around the distributor and clamp, then remove the distributor clamp bolt and clamp.
4. Withdraw the distributor from the engine.

REINSTALL

1. Align the centre line of the protruding gear retaining pin with the raised mark on the distributor body. Refer Fig. 6D-40.

The rotation of the distributor rotor during meshing of the distributor and camshaft gears will align the firing position for No. 1 spark plug. When a replacement pin is fitted, the pin does not protrude.

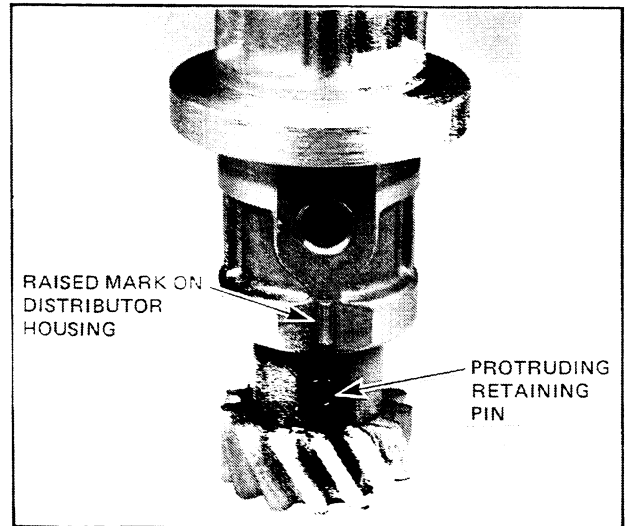

Figure 6D-40

2. Install the distributor into its position. Rotate the body so as the distributor cap clamps are at approximately 45° to the crankshaft centreline. Refer Fig. 6D-41.
3. Install distributor clamp and bolt, do not tighten bolt.

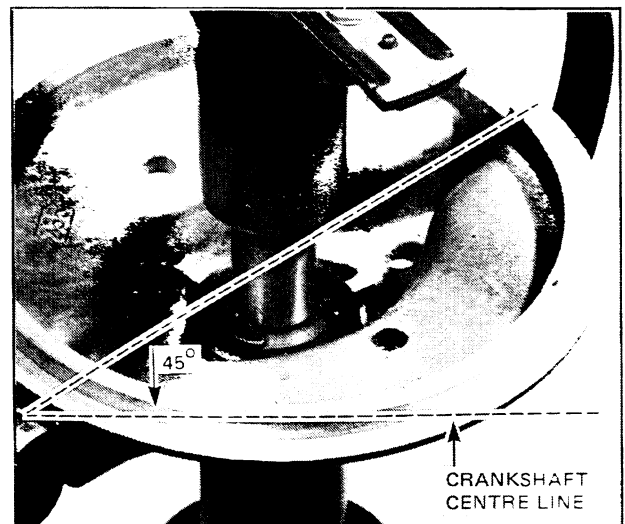

Figure 6D-41

4. Place a right angled set square across the top face of the distributor body. Align the centre mark on the rotor button and the No. 1 cylinder mark on the distributor body by rotating the body. Refer Fig. 6D-42.
5. Tighten distributor clamp bolt and install distributor cap.

If the engine is accidentally cranked after the distributor was removed, the following procedure can be used, for installing:

1. Remove No. 1 spark plug.
2. Place finger over No. 1 spark plug hole and crank engine slowly until compression is felt.
3. Align timing mark on torsional damper with the longest mark (TDC) on the front timing cover scale.
4. Install the distributor as previously outlined.

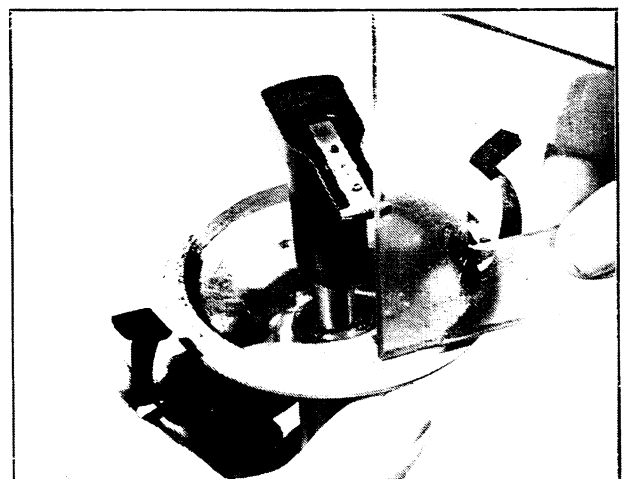

Figure 6D-42

6D-26 ENGINE ELECTRICAL

DISASSEMBLY

1. Remove distributor and rotor.
2. Remove circlip and upper distributor shaft thrust washers.
3. Press out the pin securing the drive gear and remove gear and thrust washers. Refer Fig. 6D-43.
4. Push shaft from housing by applying light force at the drive end.

REASSEMBLY

Reassembly is reverse of disassembly.

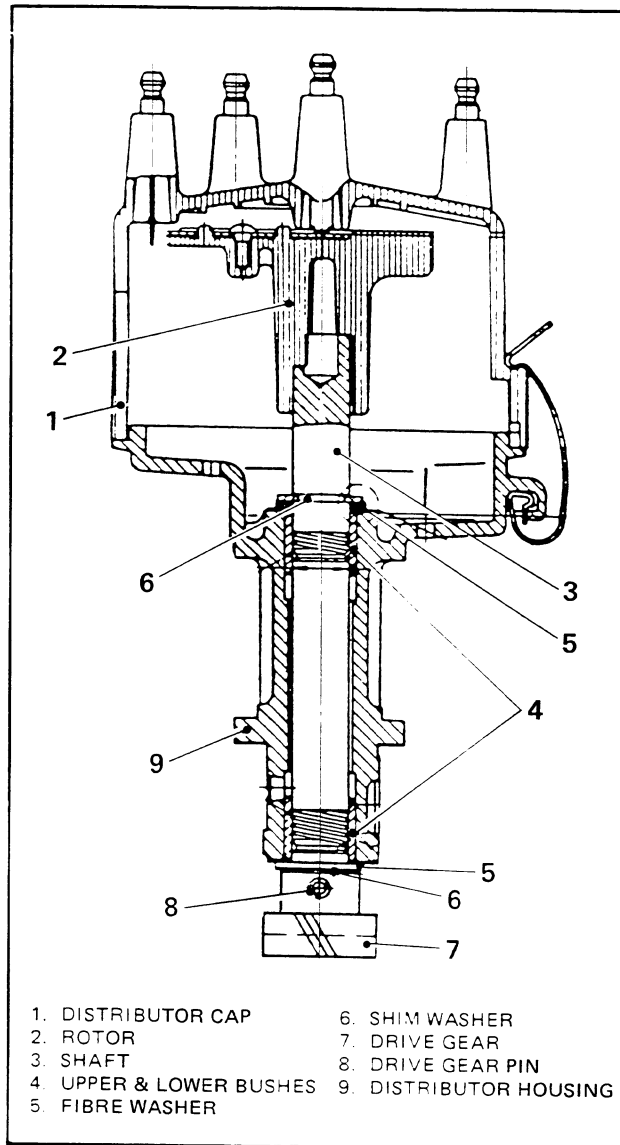

Figure 6D-43

2.4 MANIFOLD VACUUM SENSOR

REMOVE

1. Remove the two screws securing the sensor to the bottom of the fuse box. Refer Fig. 6D-44.
2. Disconnect wiring and vacuum connectors. Refer Fig. 6D-44.

REINSTALL

Installation is reversal of removal.

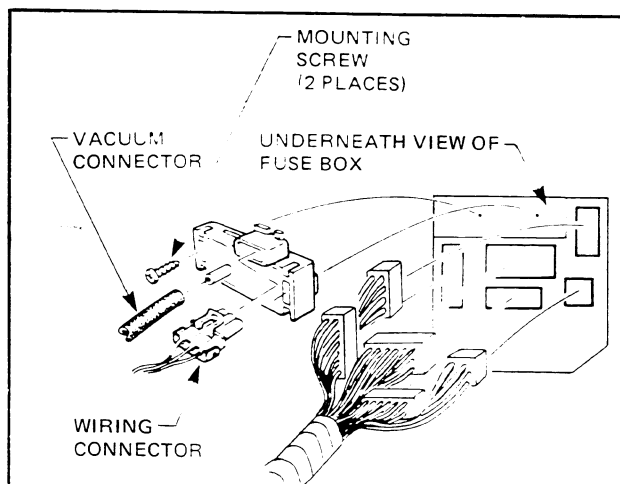

Figure 6D-44

TESTING

Testing the vacuum sensor can be done on the vehicle.

1. Disconnect sensor vacuum hose from inlet manifold adopter.
2. Use a hand vacuum pump, such as Tool No.J23987-01 or equivalent, insert end into open hose end. Refer Fig 6D-45.

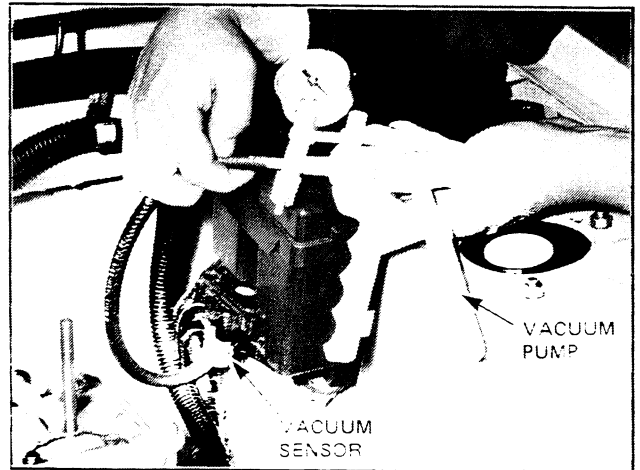

Figure 6D-45

3. Connect a voltmeter across the CB and CA terminals of the sensor. Refer Fig. 6D-46. Switch on ignition.
4. With a varying amount of vacuum, the output voltage varies according to the following table:

VACUUM APPLIED kPa	OUTPUT VOLTAGE
0	4.4 to 5.3
25	3.2 to 3.8
50	2.0 to 2.5
75	0.7 to 1.1

Any deviation in the output voltage figure with the nominated applied vacuum, indicates a faulty sensor, which must be replaced.

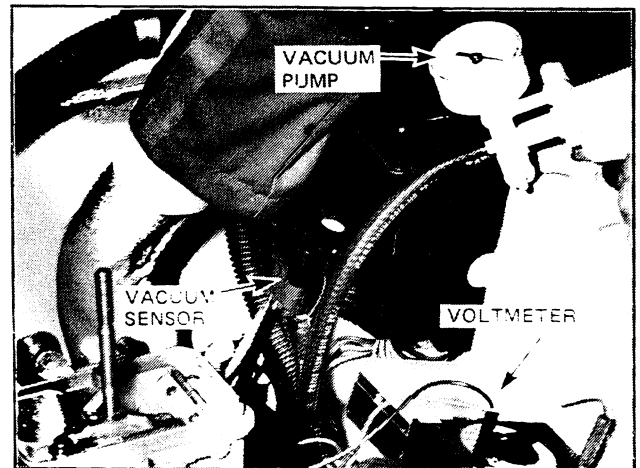

Figure 6D-46

2.5 ELECTRONIC CONTROL MODULE

REMOVE

1. Make sure ignition is switched 'off' and disconnect battery earth lead.
2. Remove the left hand cowl panel trim from the front passenger compartment.
3. Remove module mounting screws. Refer Fig. 6D-47.
4. Disconnect wiring harness and withdraw control module from its position. Refer Fig. 6D-47.

REINSTALL

Installation is the reverse of removal procedure.

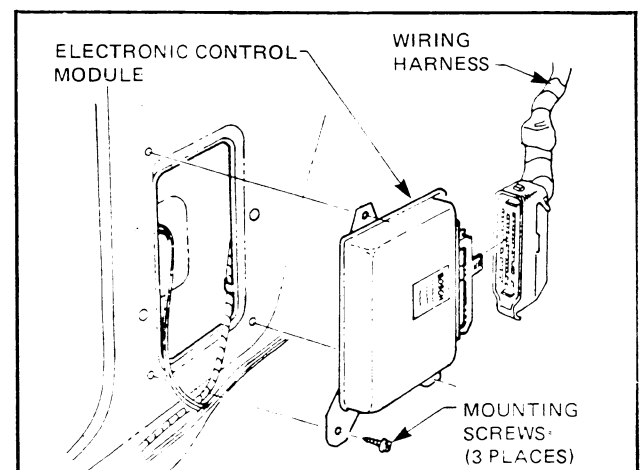

Figure 6D-47

6D-28 ENGINE ELECTRICAL

2.6 COOLANT TEMPERATURE SENSOR

REMOVE

1. Disconnect battery earth lead.
2. Disconnect wiring harness connector from temperature sensor. Fig. 6D-48.
3. Drain coolant from engine, below sensor level.
4. Remove sensor from thermostat housing.

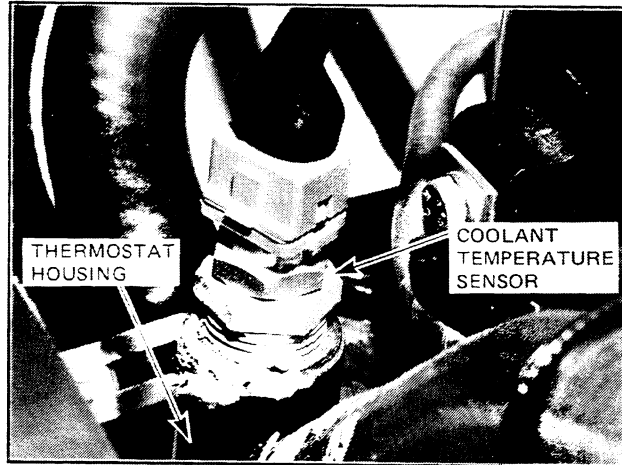

Figure 6D-48

TEST

1. Suspend sensor in a container of 50/50 glycol/water. Ensure that sensor does not touch the container.
2. Place thermometer, having a scale reading of at least 100°C, into container and heat.
3. Record resistance across sensor terminals at various temperatures. Refer Fig. 6D-49.

Check the results with the following chart.

TEMPERATURE °C	RESISTANCE ohms
0	5.4 to 6.3 k Ω
20	2.3 to 2.7 k Ω
80	300 to 350 Ω
100	170 to 210 Ω

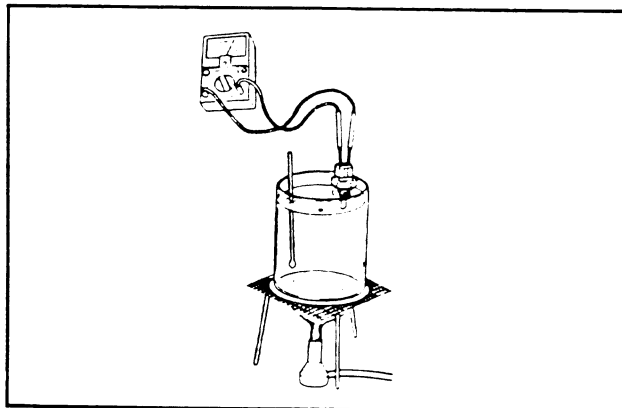

Figure 6D-49

Any deviation in the resistance values recorded at the nominated temperature readings indicates a faulty sensor which must be replaced.

REINSTALL

1. Apply GMH sealant P/N 3835214 to sensor threads, refit in thermostat housing and tighten.
2. Refit wiring harness connector.
3. Fill up radiator and check for coolant leaks.

2.7 THROTTLE POSITION SWITCH

REMOVE

1. Remove carburettor air cleaner.
2. Disconnect the two wiring connectors at switch.
3. Remove the 2 switch mounting screws, washers and mounting plate. Refer Fig. 6D-50.

REINSTALL

Installation is reverse of removal procedure. The switch must be readjusted after installation.

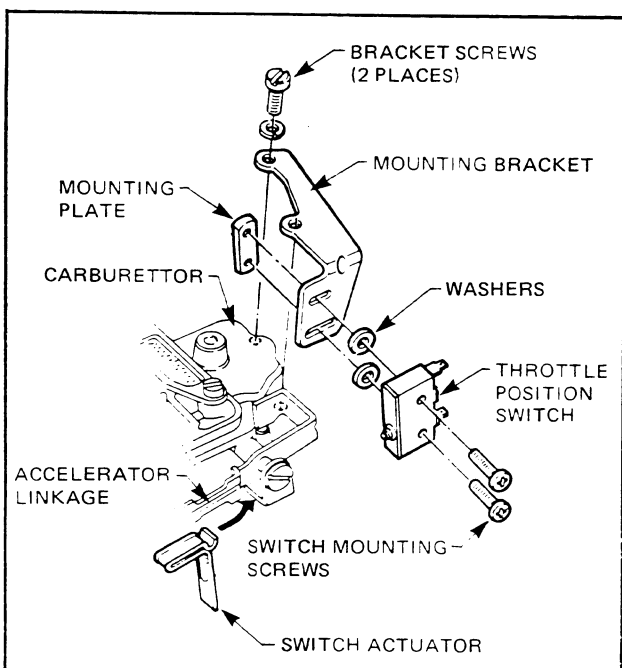

Figure 6D-50

ADJUSTMENT

1. Disconnect wiring connectors from switch.
2. Connect an ohmmeter across the switch terminals (**Do not use a test light**). Refer Fig. 6D-51.

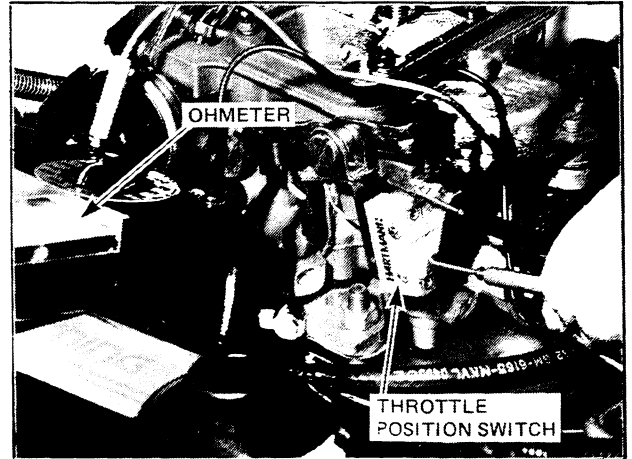

Figure 6D-51

3. Position the fast idle screw onto the second highest step of the fast idle cam. Refer Fig. 6D-52. Check that the switch is open, the ohmmeter reads infinity ohms.
4. Rotate the fast idle cam so that the fast idle screw sits on the third highest step. Check that the throttle position switch is closed, the needle of the ohmmeter reads 0 ohms. Loosen mounting screws and adjust switch as required to achieve correct adjustment.
5. When switch is correctly adjusted, tighten mounting screws and recheck adjustment.
6. Reconnect wiring connectors to switch. Reinstall carburettor air cleaner.

On vehicles with manual transmissions, for the engine to return to idle, it is essential that whenever the throttle closes onto the extended throttle nudge shaft, the throttle position switch must be closed.

If the throttle closes onto the extended nudge without closing the throttle position switch, the engine will run at approximately 1400 rpm.

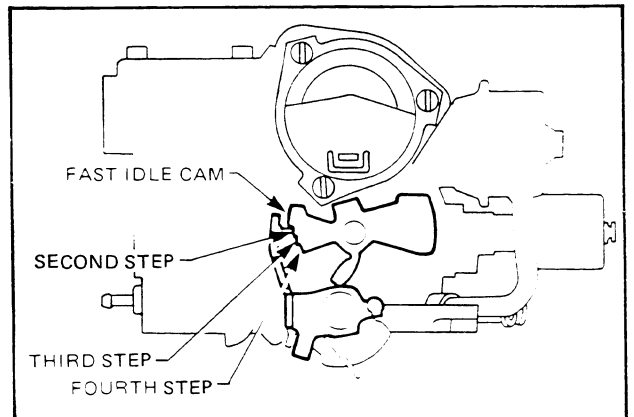

Figure 6D-52

To Check Operation

1. Disconnect throttle position switch wiring connectors and connect together (this simulates a closed switch), connect an ohmmeter across switch terminals.
2. Start the engine.
3. Open the throttle until the switch opens, (ohmmeter reads 'infinity').
4. Depress the spring loaded button on the throttle nudge and close the throttle. With the throttle lever resting on the extended nudge shaft, the ohmmeter should show zero ohms.
5. Readjust idle speed, fast idle speed, throttle position switch or throttle nudge setting to ensure correct operation.

6D-30 ENGINE ELECTRICAL

2.8 ENGINE SPEED SENSOR

TEST

1. Disconnect sensor wiring harness connection, at the fuse box side of the rocker cover. Refer Fig. 6D-53A.
2. Connect an ohmmeter across sensor terminals shown in Fig. 6D-53. Resistance should be in the range of 1 to 1.2 k Ω . Any deviation in the resistance value than specified the sensor is considered faulty and must be replaced.

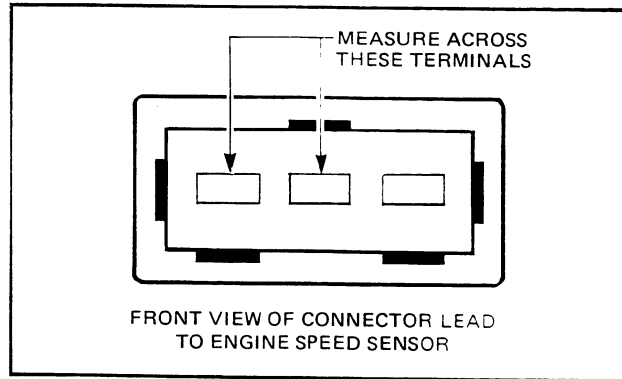

Figure 6D-53

REMOVE

1. Disconnect battery earth lead.
2. Disconnect engine speed sensor wiring harness connection, at the fuse box side of the rocker cover. Refer Fig. 6D-53A.
3. Remove engine harness strap at rear of rocker cover.
4. Remove bolt securing engine speed sensor support to the rear of the cylinder block.
5. Remove sensor assembly from its location.

NOTE: Do not damage support locating lug.

6. If necessary, mount speed sensor support carefully in a vice with soft jaws, remove mounting bolt and separate sensor from support.

REINSTALL

Installation is reverse of removal operations.

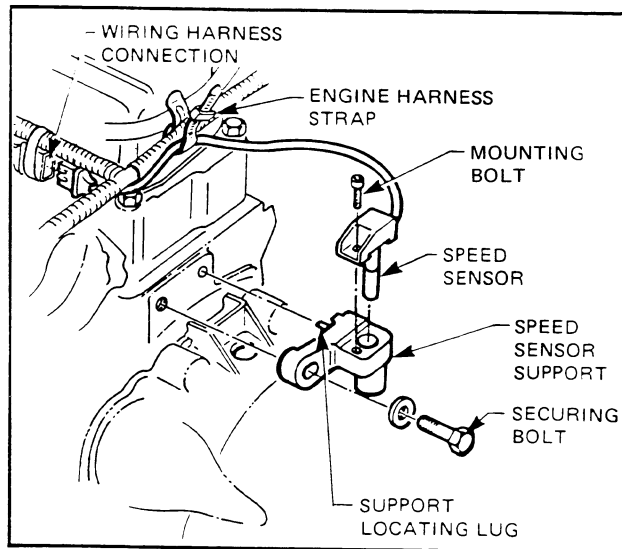

Figure 6D-53A

3. DIAGNOSIS

3.1 DIAGNOSTIC LIMP LIGHT

When the system is operating normally, the lamp is on during engine cranking and while the engine is not running with the ignition 'ON'. It will go out a few seconds after the engine starts if everything is operating normally. If the light does not come on at all, the bulb, the wiring or the module may be faulty.

The lamp will come on whilst driving for one of two reasons.

1. If the control module detects an operating fault with one of the EST system sensors.
The control module assumes a normal operating value for that sensor, and continues to supply the engine with a spark advance value, although not necessarily the optimum value.
2. It means that there is a malfunction in the control module itself. In this case the EST system will revert to a spark advance value of 6C BTDC (Limp Home Mode), this enables the vehicle to remain operational at a reduced performance level.

3.2 DIAGNOSTIC ELECTRICAL CONNECTION FOR EST

Situated within the EST engine wiring harness assembly is a single cavity connector body and terminal, taped back to the wiring harness as shown in Fig. 6D-54.

With the aid of a jumper lead fitted with alligator clips, this allows the connection of the connector body terminal to a suitable earth point on the engine. With this connection, the diagnostic limp light is activated.

The diagnostic limp light is located within the dash warning light panel. By means of a coded flashing warning, the limp light defines the source of the EST system component failure.

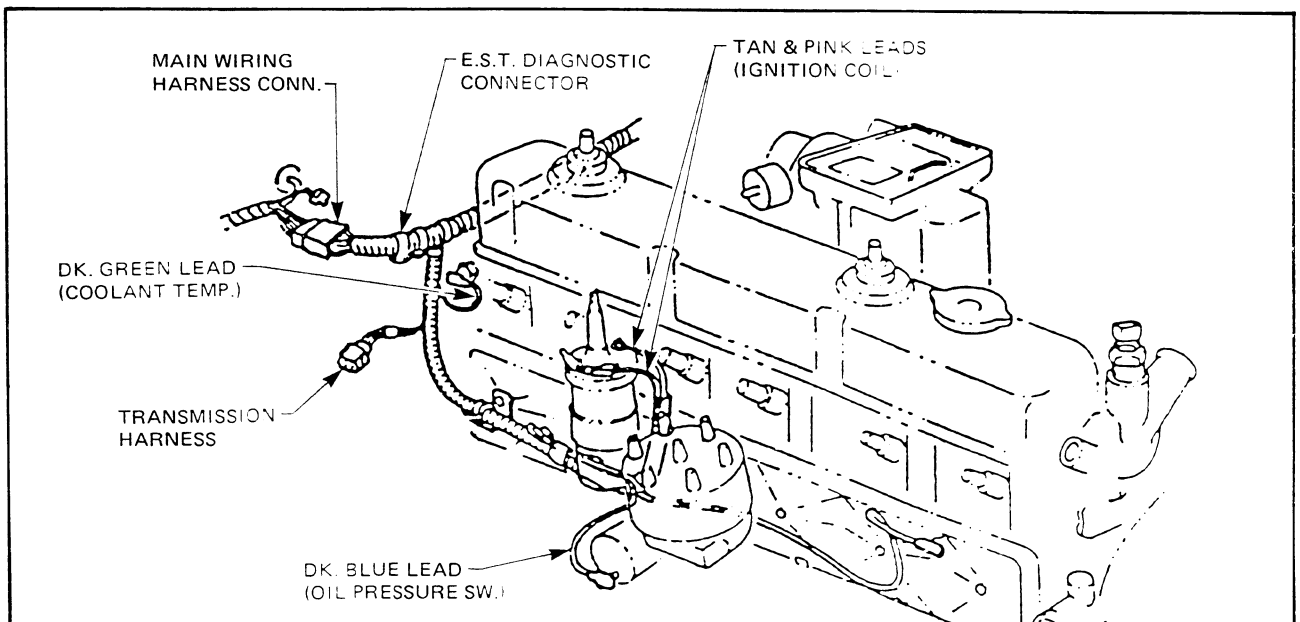

Figure 6D-54

6D-32 ENGINE ELECTRICAL

In the event of the limp light coming on to indicate a system component failure, make the earth connection to the connector body without turning off the engine, and let the engine idle.

Description of the diagnostic limp light operation is covered in 3.3 of this Section.

To reset the diagnostic lamp for normal mode condition, turn off the ignition and remove jumper lead. Restart vehicle and if the fault has not been corrected the diagnostic lamp will come on again when the appropriate test conditions are re-established.

3.3 DIAGNOSIS OF LIMP LAMP OPERATION

(Refer to chart at the end of this Section.)

LIMP HOME MODE

If the microprocessor (or computer) fails, a limp home mode is activated and the warning light is turned on. Limp home mode is provided to minimise the likelihood of the owner being stranded. Spark timing is very retarded in this mode (6° BTDC always) and this will cause increased fuel consumption, poor engine response and higher engine operating temperatures. Prolonged operation in this mode should be avoided. Monitor engine temperature regularly if limp mode operations is necessary at high ambient temperatures or while towing. Stop if necessary.

If the microprocessor starts operating normally, the light will be turned off in normal and diagnostic modes, provided no other faults have been detected. If the diagnostic light is on continuously in normal mode and does not flash a recognisable code in diagnostic mode, the EST module should be replaced.

POSSIBLE TEMPERATURE SENSOR FAULT

If a fault is detected in the temperature sensor circuit, the light is on in normal mode. In diagnostic mode, the light flashes on for 1 second in every 8 seconds.

The control module does not check the temperature sensor circuit until the ignition has been on for 8 minutes. From 8 minutes onwards the module continuously checks for a temperature between 50°C and 125°C. If the ignition is switched on without starting the engine the temperature may be outside the specified limits without a fault being present, 8 minutes after ignition 'ON'.

To check for this false indication, switch ignition off, start the engine and check the light in 8 minutes.

If the light comes on again, it may be due to either an open circuit, a short circuit or a faulty temperature sensor. A faulty sensor may give the same symptoms as an open or short circuit.

Short Circuit

If a short circuit is present, the temperature appears very high (130°C) to the module. In the 8 minutes between the ignition being turned on and the detection of the fault, the module will increase idle spark advance as if the temperature really were high. This is done to increase idle speed for improved engine cooling.

After the 8 minute period is complete, the module detects the fault, turns the warning light on (or flashes the diagnostic code in diagnostic mode) and assumes a normal temperature (90°C). The light remains on continuously in normal mode (or continues to flash in diagnostic mode) until the ignition is switched off.

When the light comes on, the idle speed will return to normal as the very high temperature is no longer seen.

Open Circuit

If an open circuit fault is present, the temperature appears very low (-14°C) to the module. If the temperature at ignition key on is low, the idle low temperature compensation is enabled. For the first 12 minutes of engine operation, idle spark advance is increased for improved idle quality. Note that this will cause the idle speed of a warm engine to fluctuate about 900 rpm. This is because additional advance is only present at idle, which is defined as engine speed less than 900 rpm and idle switch closed.

If the speed is above 900, the advance is slowly removed and the engine slows. If it is below 900 rpm, the advance increases and the speed increases. This provides engine idle speed governing at 900 rpm.

After 8 minutes of operation with the open circuit fault, the module turns the light on (or flashes the code in diagnostic mode), assumes a normal operating temperature and continues to provide additional spark advance at idle until 12 minutes after ignition key on.

POSSIBLE VACUUM SENSOR OR THROTTLE POSITION SWITCH FAULT (1)

Whenever the engine is operating, the module is checking for a vacuum sensor fault.

If the throttle position switch is closed and the engine speed exceeds 1500 rpm, the module expects to see a manifold vacuum greater than 30 kPa. If the module detects a vacuum of less than 30 kPa under these conditions, it will turn the diagnostic light on (or give 2 flashes every 8 seconds in diagnostic mode) and assume the manifold vacuum is zero at all times.

If the engine is switched off and re-started, the light will go out until the engine speed exceeds 1500 rpm while the throttle position switch is closed. If the vacuum is again seen by the module as less than 30 kPa, the light will be turned on again.

This fault will be indicated if the hose comes off the vacuum sensor, if the signal wires in the vacuum sensor harness are shorted together or if the vacuum sensor is faulty. This fault may also be indicated if the throttle position switch wires are shorted together or to ground or the switch itself is badly adjusted or short circuited. For example, the engine may be operating at 1600 rpm wide open throttle and with zero vacuum. If the throttle position switch is operating normally, it will be open and no fault will be recorded. If the throttle position switch wires are shorted together, the module sees the same input as a closed switch and records a fault condition.

It is necessary to assume the engine is operating at zero vacuum all the time this fault is present. This is to prevent the module from giving the engine excessive advance at wide open throttle and causing detonation damage.

POSSIBLE VACUUM SENSOR OR THROTTLE POSITION SWITCH FAULT (2)

This section describes a second test for a possible vacuum sensor fault. If the throttle position switch is closed and the engine speed is between 825 and 900 rpm, the module expects to see a manifold vacuum of between 10 kPa and 75 kPa.

If the module detects a vacuum outside these limits it will turn the diagnostic light on (or give 3 flashes every 8 seconds in diagnostic mode) and assume the manifold vacuum is zero at all times.

If the engine is switched off and re-started, the light will go out until the check conditions are met and the fault re-detected. This fault will be indicated if the electrical connector comes off the vacuum sensor, a vacuum sensor wire is broken or the vacuum sensor is faulty. It may also be indicated if the throttle position switch wires are shorted together or to ground or the switch itself is short circuited.

EST DIAGNOSTIC LAMP CHART

FAULT DESCRIPTION	FAULT CONDITION	LIMP LIGHT OPERATION		CORRECT SYSTEM OPERATION
		Diagnostic Mode	Normal Mode	
Possible EST Control module fault	Control module selects limp mode	* Lamp uncontrolled usually off	Lamp on until reset is successful	With ignition pulses from the control module the limp light is not triggered
Possible engine coolant temperature sensor fault	Assumes engine coolant temperature = 95°C	One pulse of lamp every 8 seconds	Lamp on until reset is successful	After the engine has been running for 8 minutes, the engine temperature will be between 50°C to 125°C
Possible vacuum sensor or throttle position switch fault (1)	Assumes vacuum is 0 kPa with the throttle position switch open or closed	Two pulses of lamp every 8 seconds	Lamp on until reset is successful	With throttle position switch closed, engine vacuum must be greater than 30 kPa provided the engine speed is greater than 1500 rpm
Possible vacuum sensor or throttle position switch fault (2)	Assumes vacuum is 0 kPa with the throttle position switch open or closed	3 pulses of lamp every 8 seconds	Lamp on until reset is successful	With throttle position switch closed and engine idling between 850 and 900 rpm the engine vacuum must be between 10 and 75 kPa

* Because of the nature of this failure it is not possible to state whether the lamp will be on or off or flashing. However if the lamp does flash it is very unlikely that it will correspond to any of the valid diagnostic codes. Despite this it should be obvious that the EST is in the limp home mode, due to the vehicles performance.

6D-34 ENGINE ELECTRICAL

INITIAL CHECKS

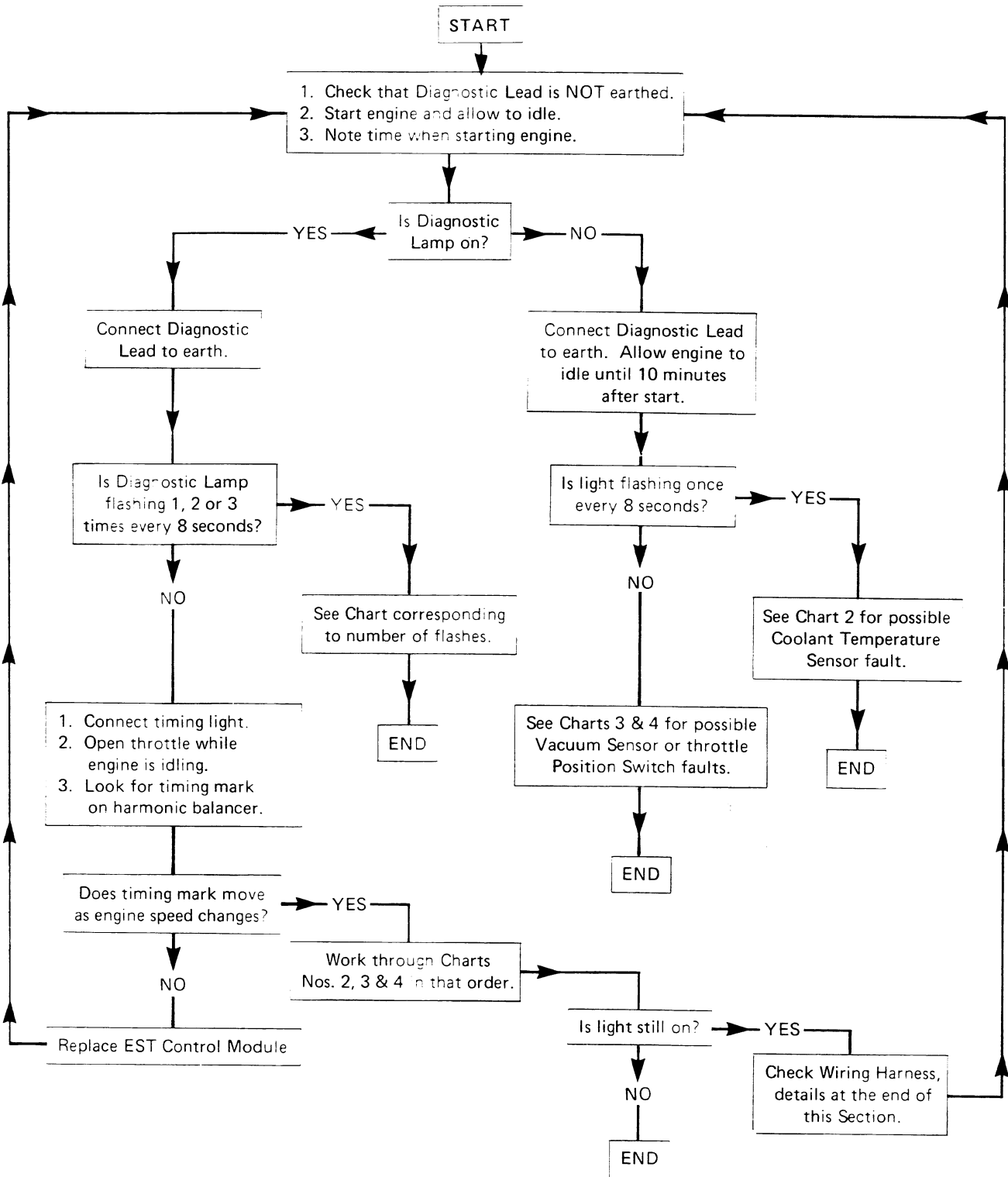

CHART 1.

**E.S.T. DIAGNOSTIC LIGHT FLASHES THREE TIMES IN DIAGNOSTIC MODE.
POSSIBLE ENGINE VACUUM SENSOR OR THROTTLE POSITION SWITCH FAULT.**

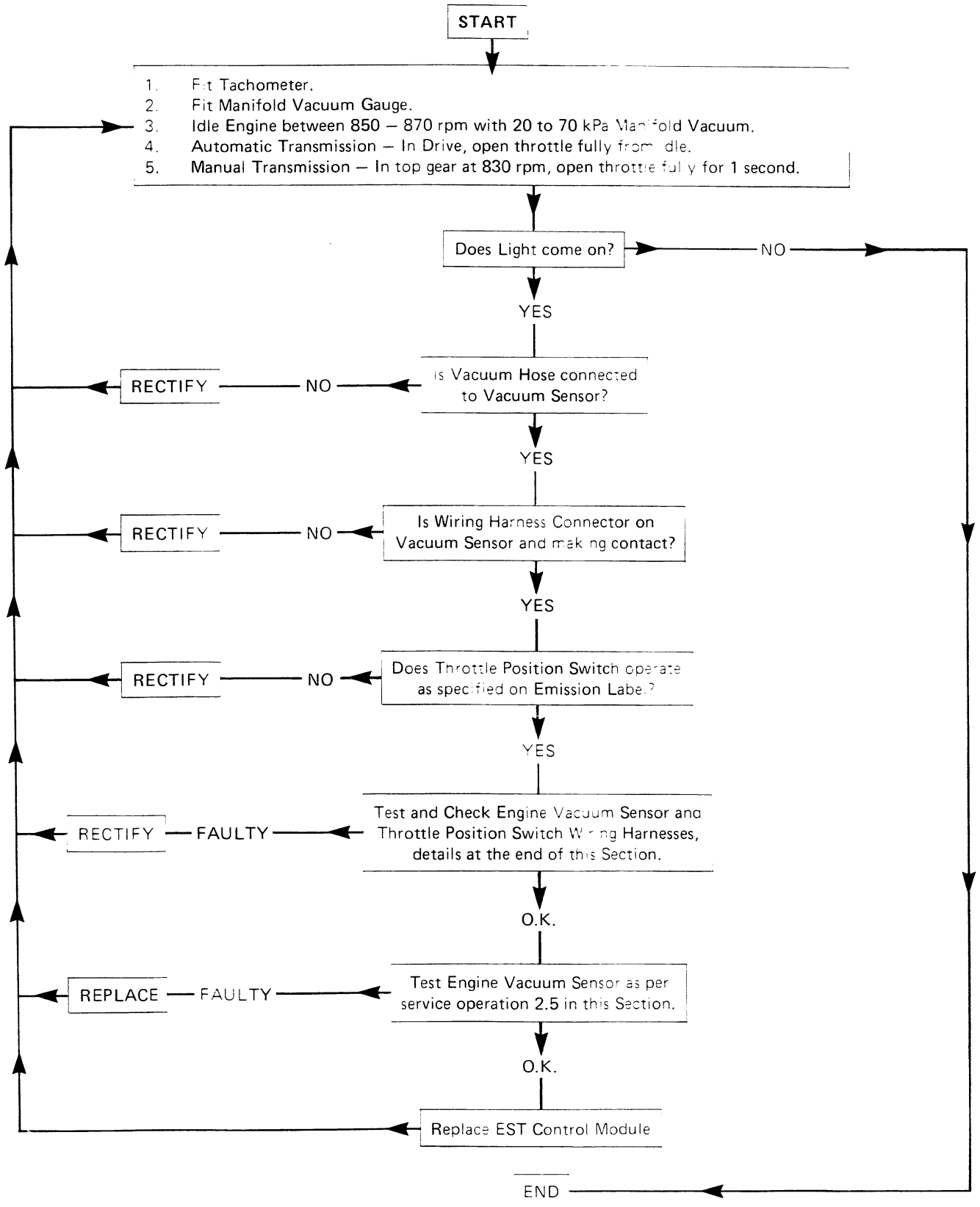

CHART 2.

6D-36 ENGINE ELECTRICAL

E.S.T. DIAGNOSTIC LIGHT FLASHES TWICE IN DIAGNOSTIC MODE.
POSSIBLE ENGINE VACUUM SENSOR OR THROTTLE POSITION SWITCH FAULT.

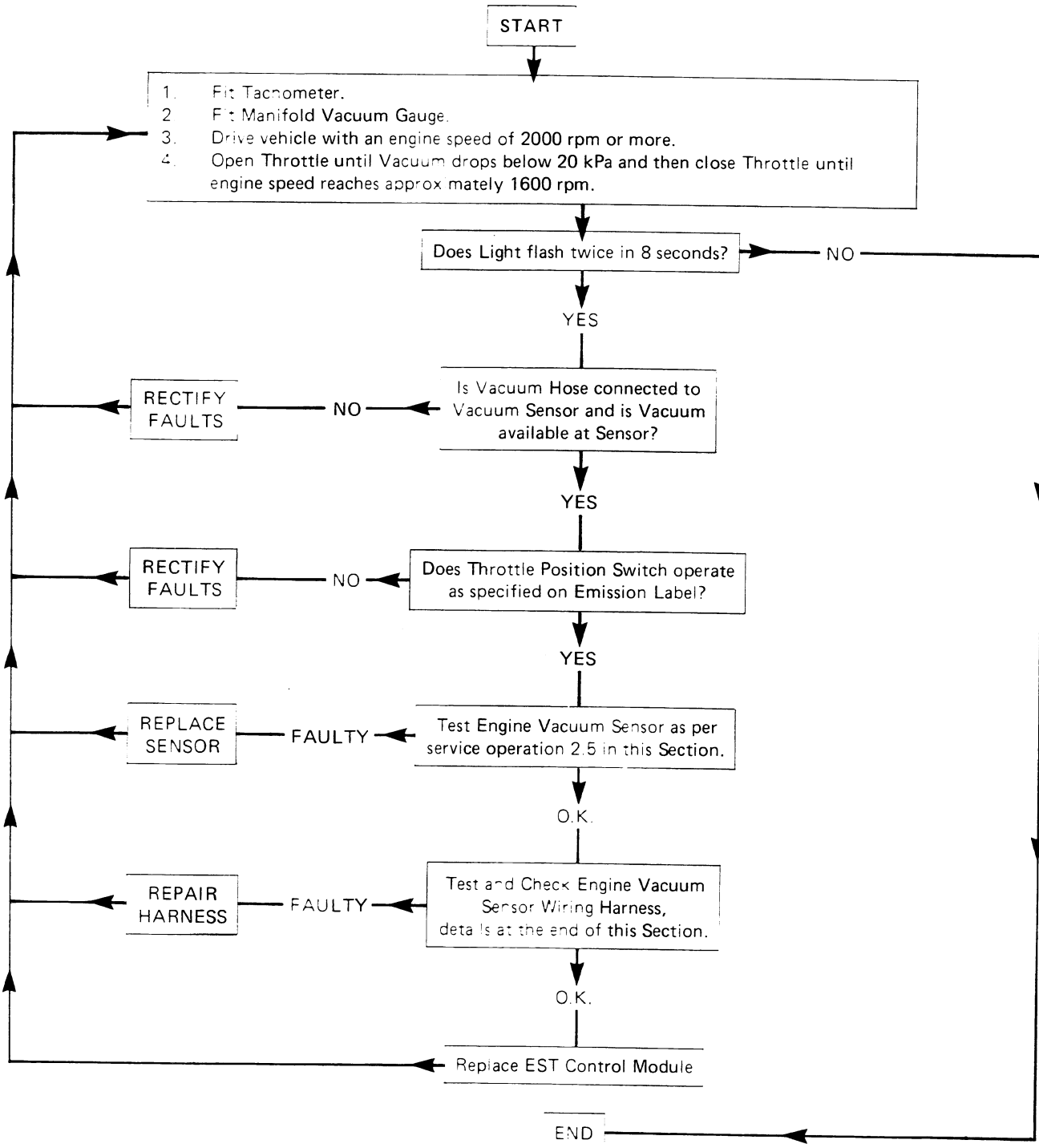

CHART 3.

ENGINE ELECTRICAL 6D-37

E.S.T. DIAGNOSTIC LAMP FLASHES ONCE IN DIAGNOSTIC MODE.
POSSIBLE COOLANT TEMPERATURE SENSOR FAULT.

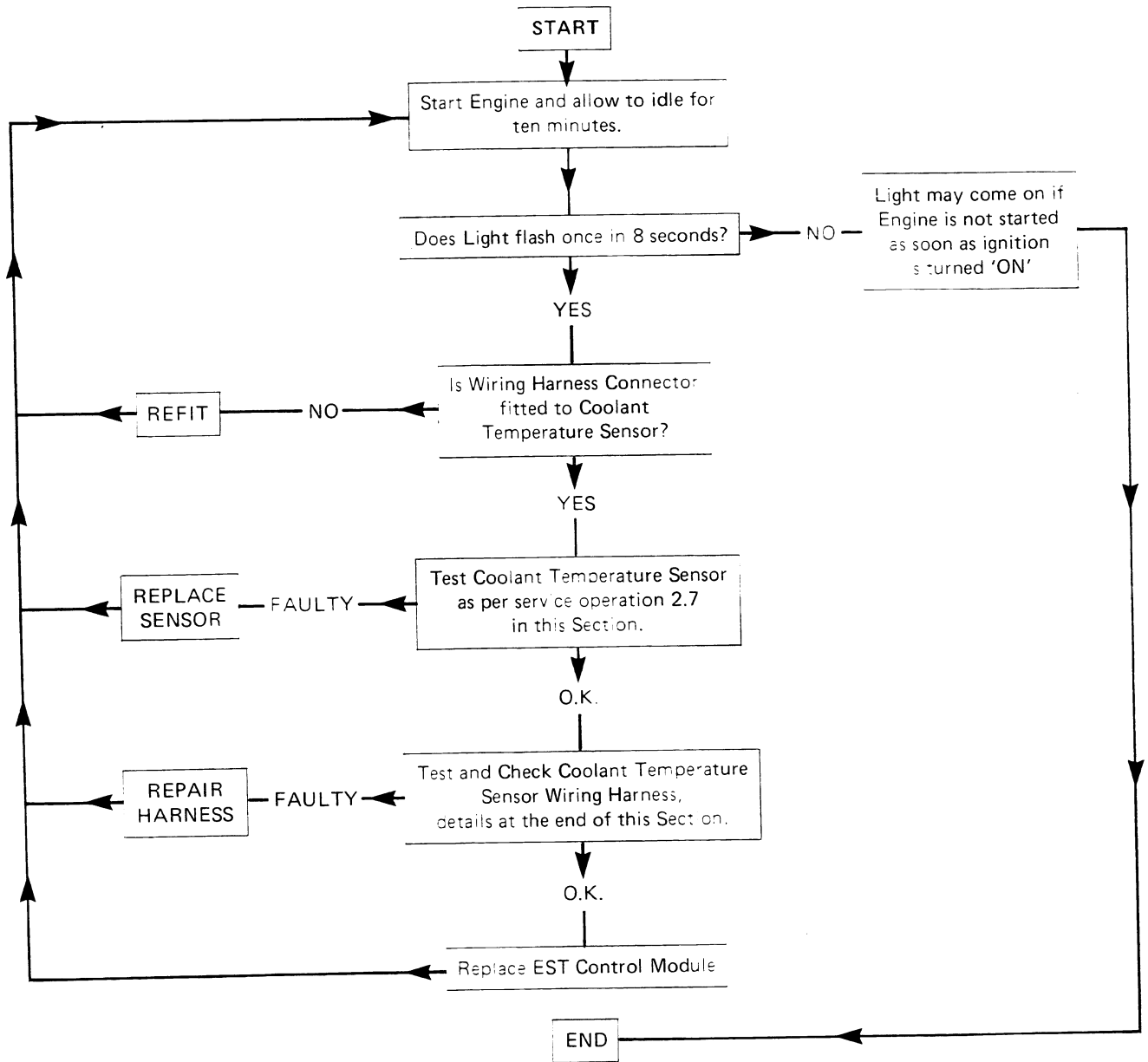

CHART 4.

6D-38 ENGINE ELECTRICAL

3.4 WIRING HARNESS CHECKING PROCEDURE

1. Remove electronic control module as per service operation 2.6.
2. Separate the EST wiring harness from the control module.
3. Since the contact terminals on the plug strip are not marked, the contacts must be counted for the various tests.

Terminals 1 through 13 are located on the long terminal strip, terminal 1 is next to the cable entrance. Refer Fig. 6D-55.

Terminals 14 through 25 are located on the short terminal strip, terminal 14 is next to the cable entrance. Refer Fig. 6D-55.

4. Remove the wiring harness connector from the EST sensor to which the test is directed.
5. Using an ohmmeter, connected to the appropriate terminal on the plug strip and the terminal on the disconnected sensor harness plug, check the wiring for:
 - a. Short circuit.
 - b. Open circuit.
 - c. Short circuit to earth.

Refer to following chart and Fig. 6D-56 for details.

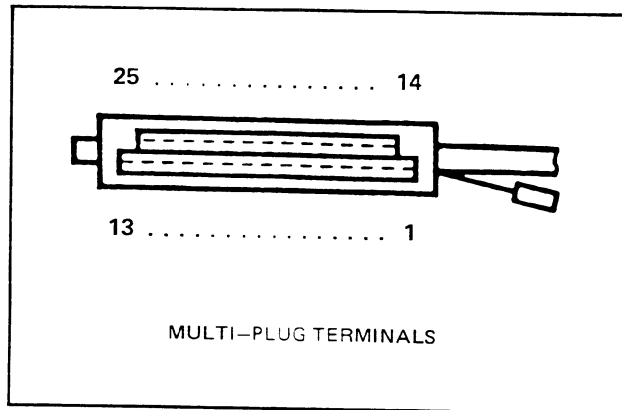

Figure 6D-55

SENSOR	TERMINAL NO.	HARNESS CONNECTOR TERMINAL
Speed Sensor	22	Black wire
	5	Black/White wire
Coolant Temperature Sensor	3	Black wire
	6 *	Black White wire
Throttle Position Switch	6	Black White wire
	4	Black wire
Ignition Coil	15	- coil terminal connector
Engine Vacuum Sensor	21	A
	24	B
	19	C

* Remove wiring connectors from throttle position switch before checking.

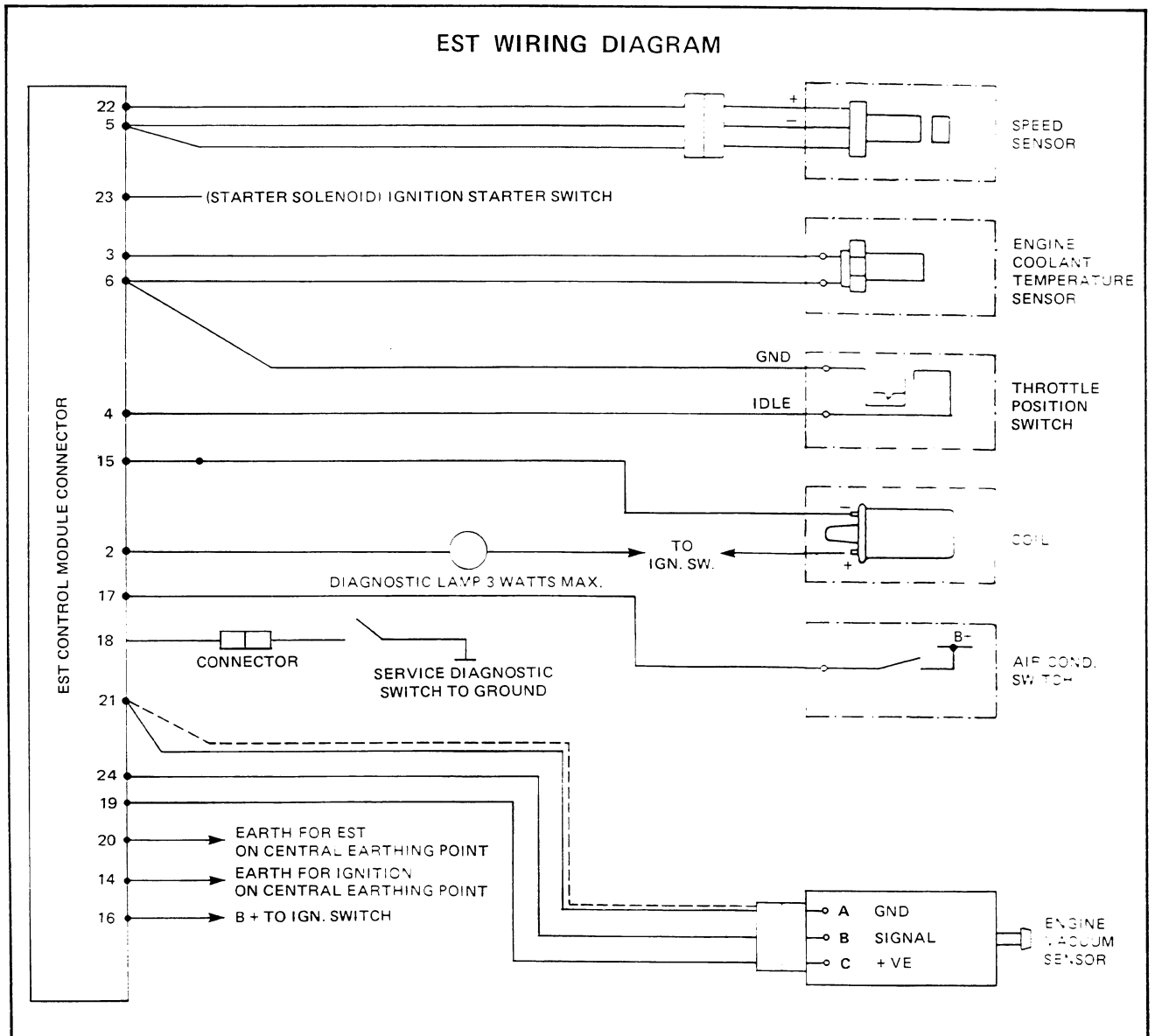

Figure 6D-56

6D-40 ENGINE ELECTRICAL

4. SPECIFICATIONS

ENGINE DESIGNATION	3.3 litre EST, EFI	5.0 litre
Distributor		
Make	Bosch	
Spark Advance	Refer "Ignition Distributor Advance Details" Chart on following page. (3.3 litre EFI and 5.0 litre only.)	
Pick up Coil Resistance	1.0 – 1.2 Kil OHM @ 25°C	
Firing Order	1, 5, 3, 6, 2, 4	1, 2, 7, 8, 4, 5, 6, 3
Coil		
Make	Bosch	
Current		
Engine Stopped	0	
Engine Idling	7 amps	
Primary Coil		
Resistance	0.5 – 0.7 OHMS @ 25°C	
Secondary Coil		
Resistance	5 – 7 Kilo OHM @ 25°C	
Spark Plugs		
Make	AC	
Model	C42CLTSX	44TX
Tread	14 mm	
Gap	1.5 mm (.060 in.)	
Tighten Torque	17 – 18 Nm	
High Tension Lead Resistance	2000 to 8000 OHMS per 300 mm	

IGNITION DISTRIBUTOR ADVANCE DETAILS

APPLICATION	DIST. PART NUMBER	INITIAL DIST. ADVANCE (DEGREES) (BTDC)	CENTRIFUGAL ADVANCE ENG. DEGREES AT ENG. R.P.M.			VACUUM ADVANCE ENG. DEGREES @ kPa		IDENTIFICATION ON WHITE LABEL ON VACUUM ADVANCE UNIT
			START	INTERMEDIATE	FULL	START	FULL	
3.3 litre EFI	92C17790	12 BELOW 1100 RPM	-3.0 to 1.0 @ 1200	9.5 to 13.5 @ 2400	16.0 to 20.0 @ 5000	0 @ 17	11 – 15 @ 34	BLACK 12°
5.0 litre	92023157	6 BELOW 850 RPM	-2 to 2 @ 1000	8 to 12 @ 2000	20 to 24 @ 4400	0 @ 22 – 29	14 – 18 @ 42 – 47	BLACK 6°

5. TORQUE WRENCH SPECIFICATIONS

	Nm
Throttle Position Switch	
Mounting Screw to Plate5 – .7
Mounting Bracket to Carburettor	3.5 – 4.5
Engine Speed Sensor	
Sensor Support to Cylinder Block Bolt	30 – 40
Sensor to Support Bolt	8 – 11
Engine Vacuum Transducer	
Mounting Screws to Fuse Box	1.5 – 2.0

6. SPECIAL TOOLS

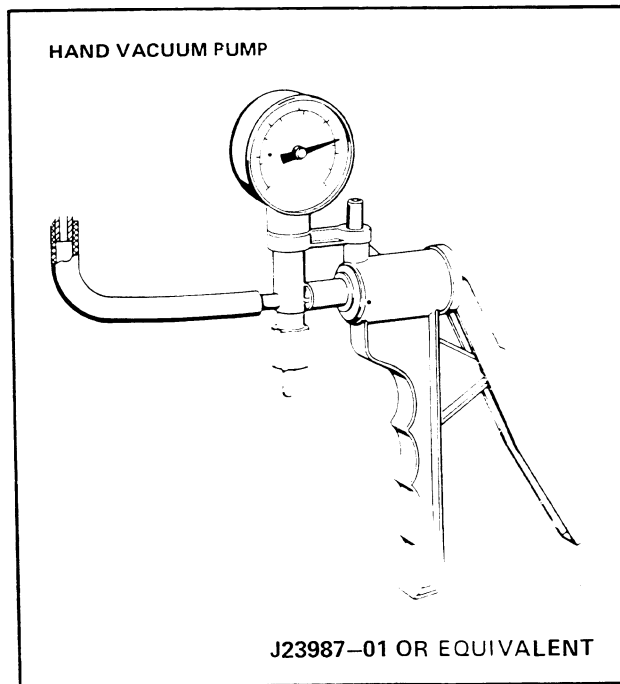

SECTION 6E

EMISSION CONTROL

INDEX

Ref.	Subject	Page	Ref.	Subject	Page
1.	GENERAL DESCRIPTION	6E-1	1.8	THROTTLE NUDGER	6E-16
1.1	EARLY FUEL EVAPORATION	6E-5	2.	SERVICE OPERATIONS	6E-17
1.2	EVAPORATIVE EMISSION CONTROL	6E-5	2.1	GENERAL INFORMATION	6E-17
1.3	POSITIVE CRANKCASE VENTILATION	6E-6	2.2	EGR MODULATOR VALVE	6E-17
1.4	VACUUM ADVANCE CONTROL	6E-9		Test	6E-17
	VAC System (NSW)	6E-9	3.	SPECIAL TOOLS	6E-18
1.5	AIR PREHEAT	6E-14			
1.6	AIR INJECTION REACTOR	6E-14			
1.7	EXHAUST GAS RECIRCULATION	6E-14			
	3.3 Litre EFI Engines	6E-14			
	3.3 Litre EST Engines	6E-14			

1. GENERAL DESCRIPTION

The Emission Control Systems employed on VK Series vehicles carry over in general from VH. However, significant revisions to some systems have been made to suit specific engine requirements.

The chart below sets out the Emission Control Systems applicable to the various engines used in VK Series.

EMISSION CONTROL SYSTEM	L6 3.3 EST	L6 3.3 EFI	5.0 L
Early Fuel Evaporation	X	N/A	X
Evaporative Emission Control	X	X	X
Positive Crankcase Ventilation	X	X	X
Vacuum Advance Control	N/A	X	X
Air Preheat	X	N/A	X
Air Injection Reactor	X	N/A	N/A
Exhaust Gas Recirculation	X	X	X
Throttle Nudger	Manual only	N/A	N/A

N/A = Not Applicable

The following paragraphs summarise the changes to the systems for VK Series.

6E-2 EMISSION CONTROL

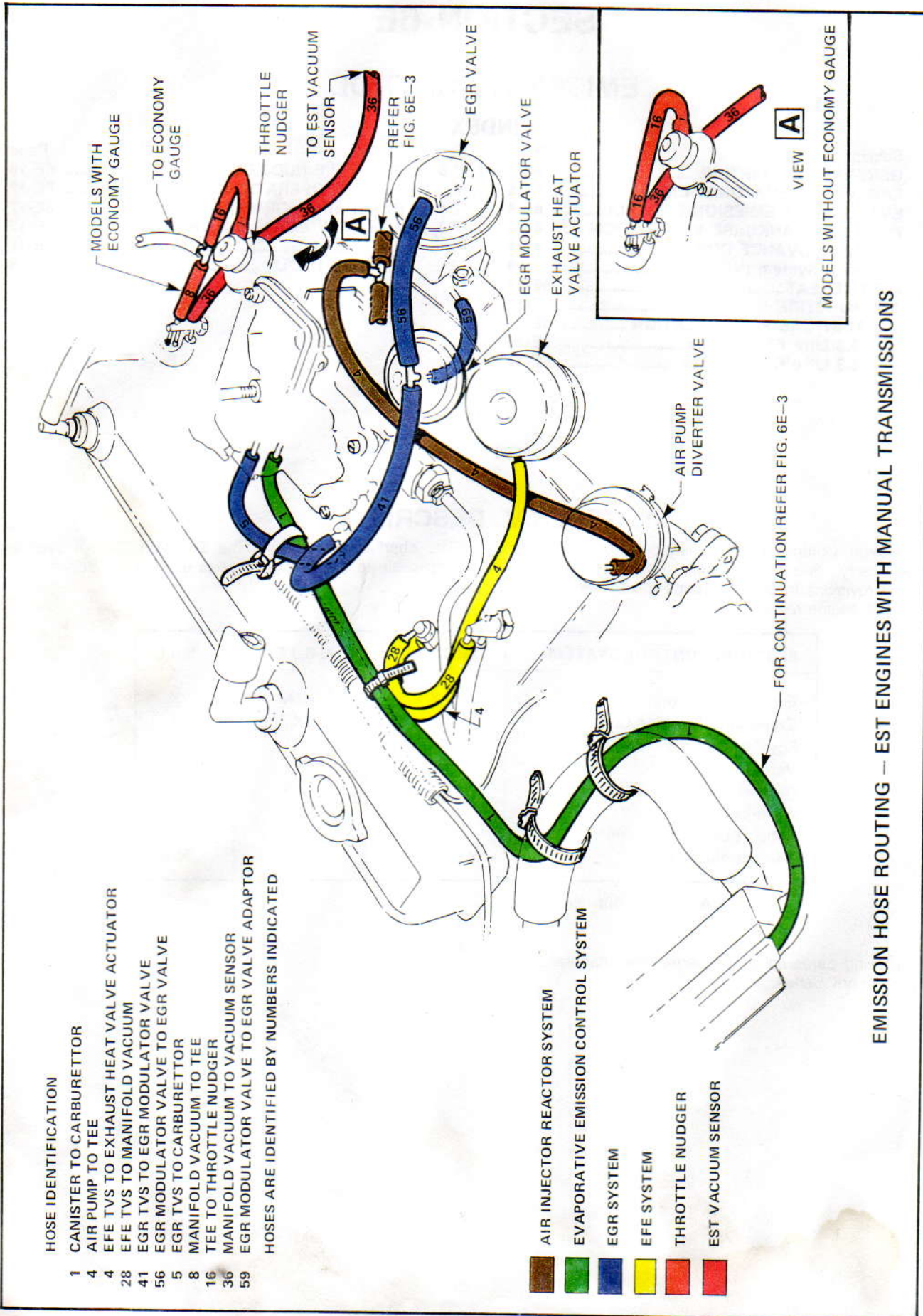

EMISSION HOSE ROUTING -- EST ENGINES WITH MANUAL TRANSMISSIONS

Figure 6E-1

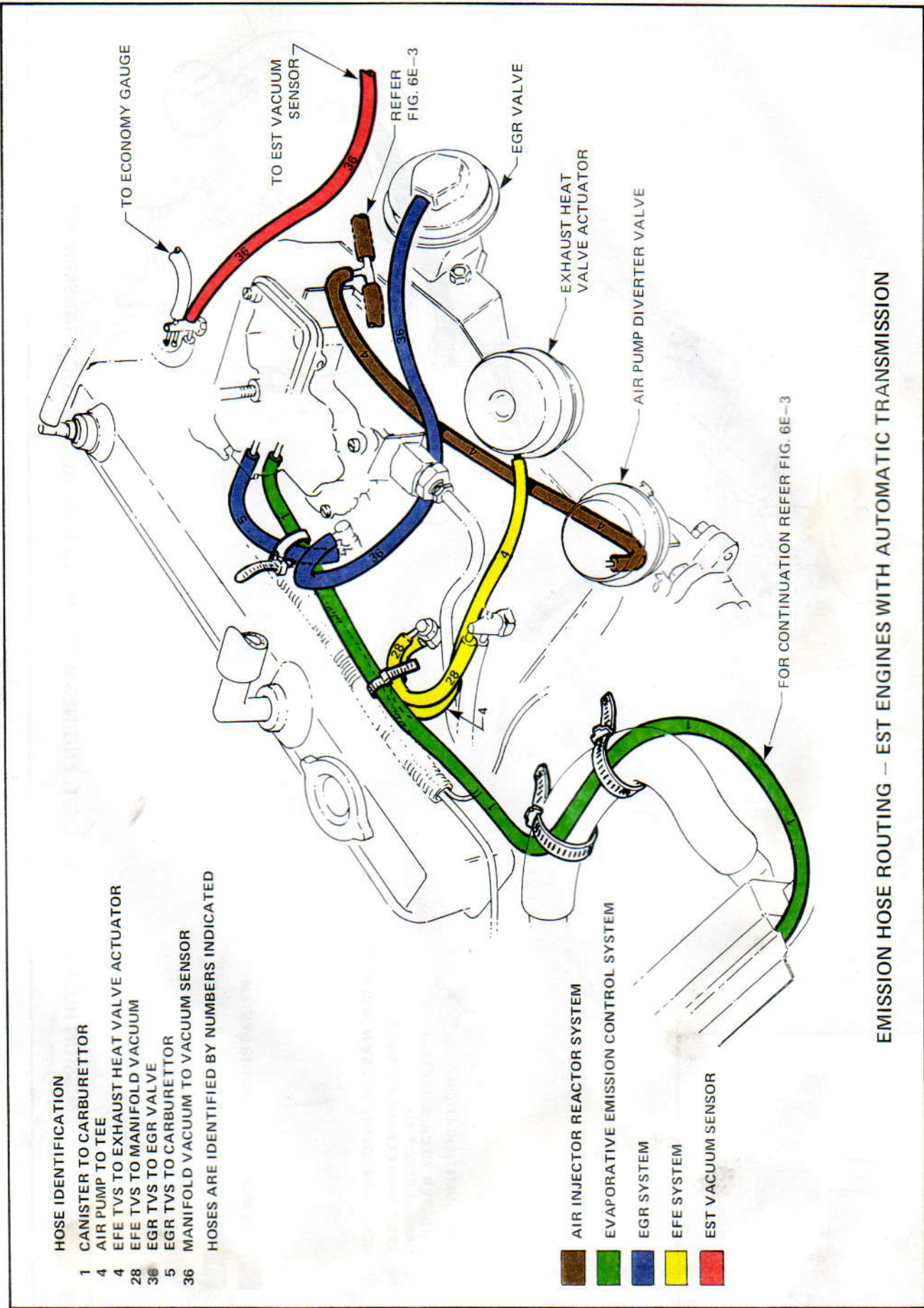

EMISSION HOSE ROUTING - EST ENGINES WITH AUTOMATIC TRANSMISSION

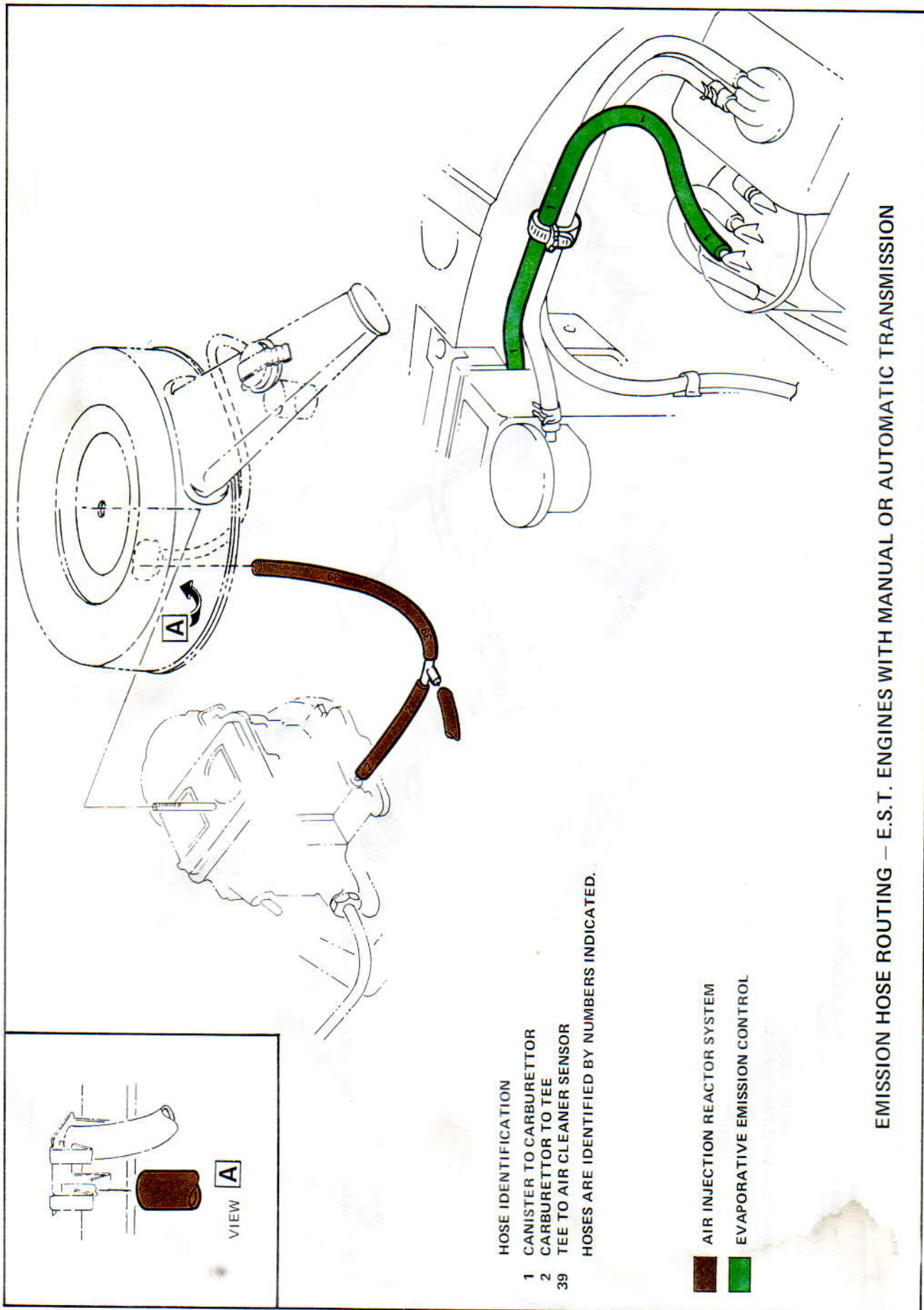

Figure 6E-3

1.1 EARLY FUEL EVAPORATION

The EFE system is carried over from VH for the L6, 3.3 EST engines and 5.0 litre engines. Refer Figs. 6E-1, 6E-2 and 6E-3 for hose routing for L6, 3.3 EST engines. 5.0 litre engine hose routing carries over from VH. The EFE is not used on engines with electronic fuel injection.

1.2 EVAPORATIVE EMISSION CONTROL

On L6 engines, the EEC system has been modified to meet emission requirements. The cannister has been relocated in the engine compartment and has new mounting brackets (Fig. 6E-4). Refer Figs. 6E-1, 6E-2 and 6E-3 for EEC hose routing.

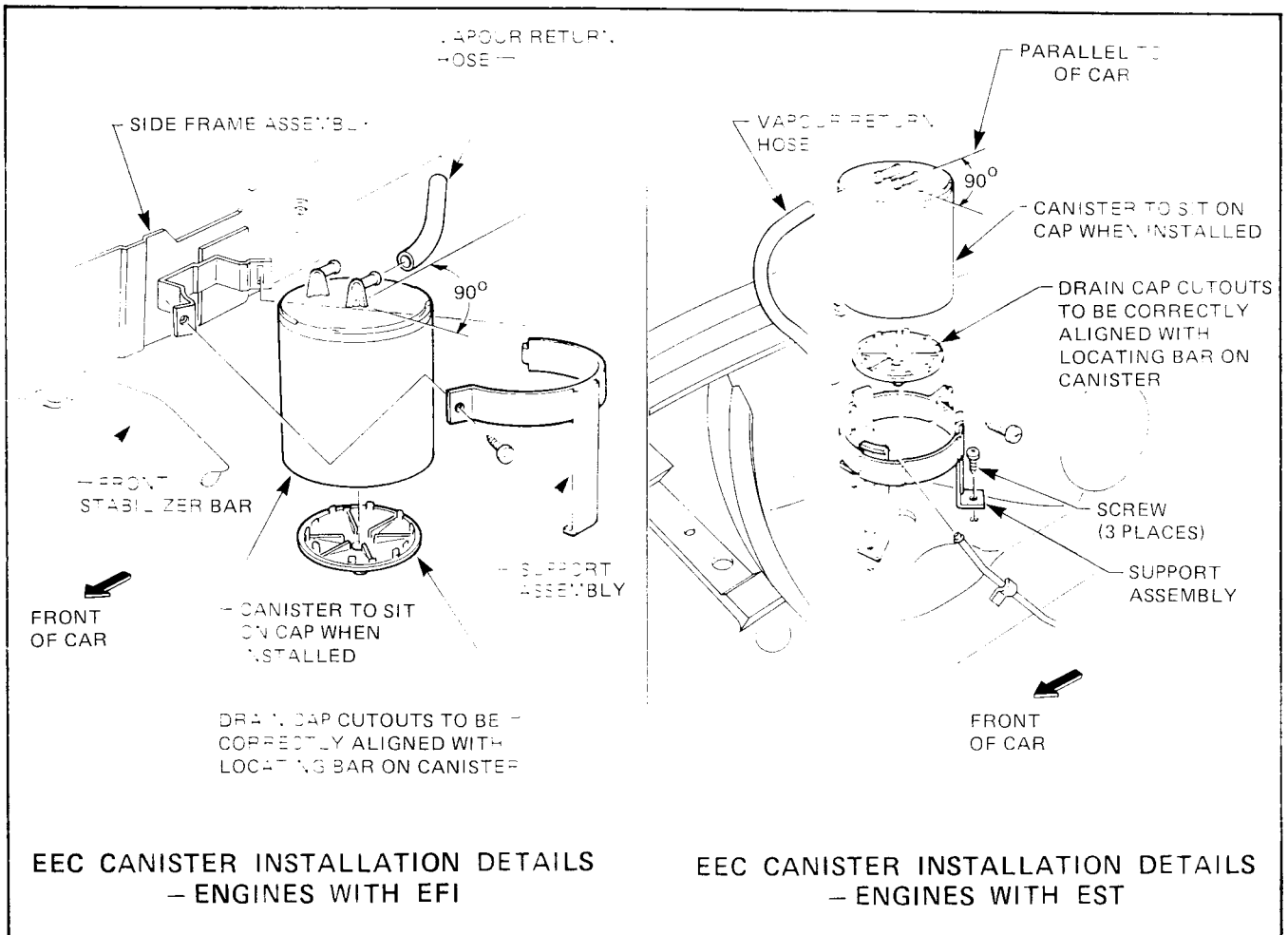

Figure 6E-4

6E-6 EMISSION CONTROL

1.3 POSITIVE CRANKCASE VENTILATION

The PCV systems for L6, 3.3 engines with EST and the 5.0 litre engine, carry over from VH. The system layout has been revised for engines with EFI. Refer Fig. 6E-5 for details.

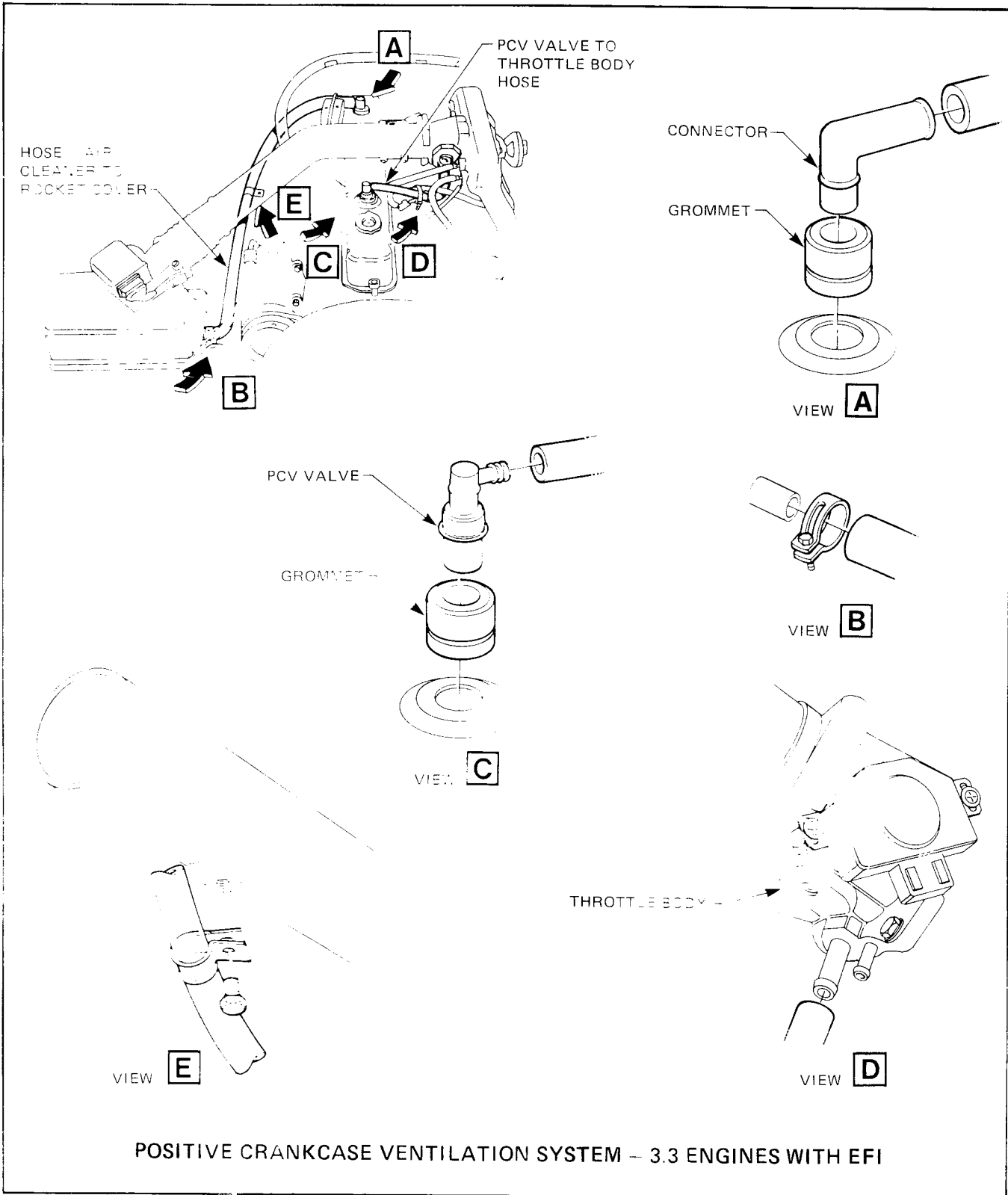

Figure 6E-5

HOSE IDENTIFICATION

- 60 CANISTER TO THROTTLE BODY PURGE
- 55 E.G.R. TO E.G.R. T.V.S.
- 61 THROTTLE BODY TO E.G.R. T.V.S.
- 3 FUEL PRESSURE REG. TO VACUUM SOURCE
- 38 T.V.S. 104°C TO THROTTLE BODY
- 15 T.V.S. 104°C TO VACUUM SOURCE
- 32 T.V.S. 104°C TO DISTRIBUTOR

HOSES ARE IDENTIFIED BY NUMBERS INDICATED.

- VAC SYSTEM
- EVAPORATIVE EMISSION CONTROL SYSTEM
- EGR SYSTEM
- FUEL PRESSURE REGULATOR

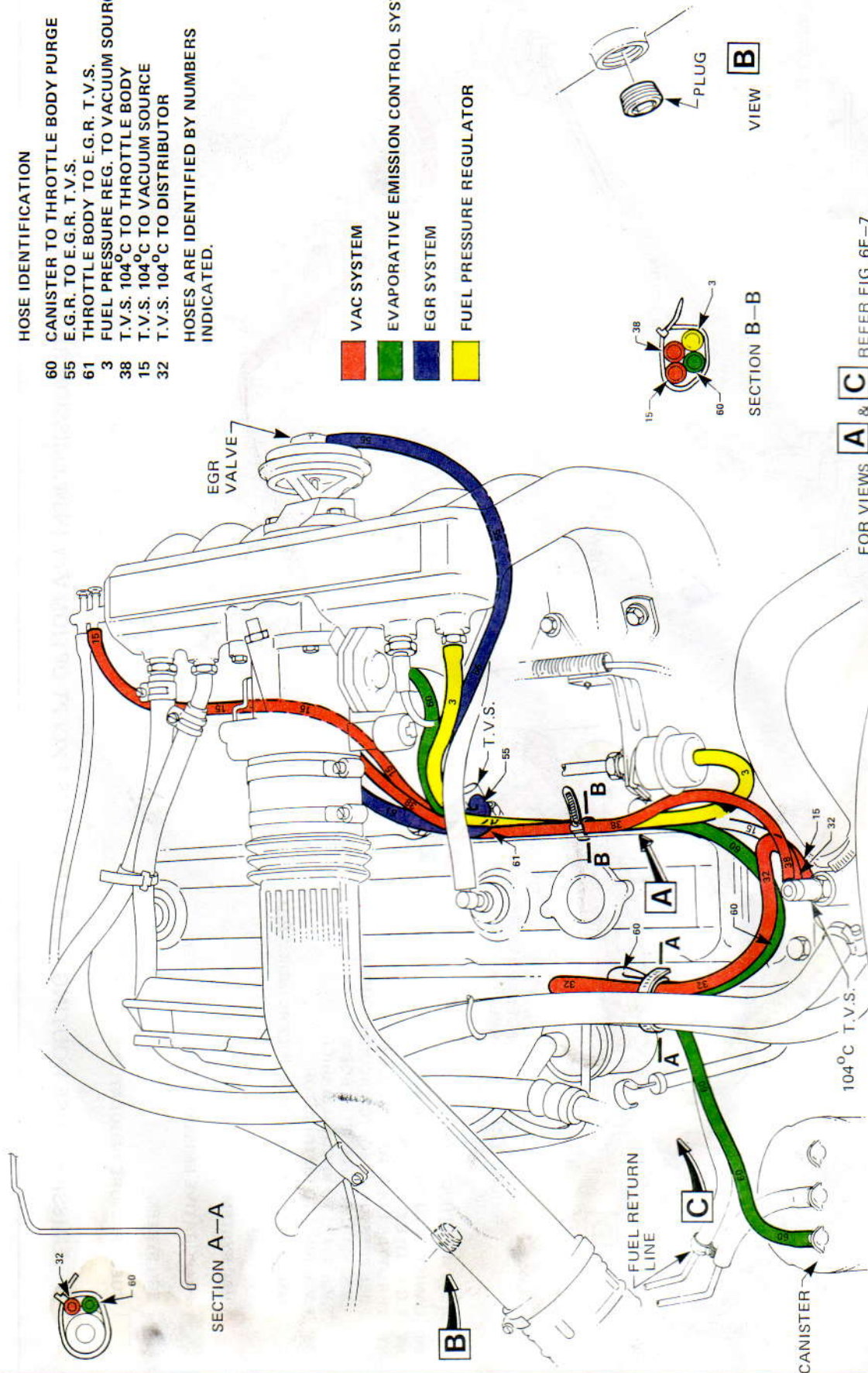

EMISSION HOSE ROUTING — E.F.I. ENGINES EXCEPT OPTION V7Y (NSW EMISSION REQUIREMENTS)

Figure 6E-6

6E-8 EMISSION CONTROL

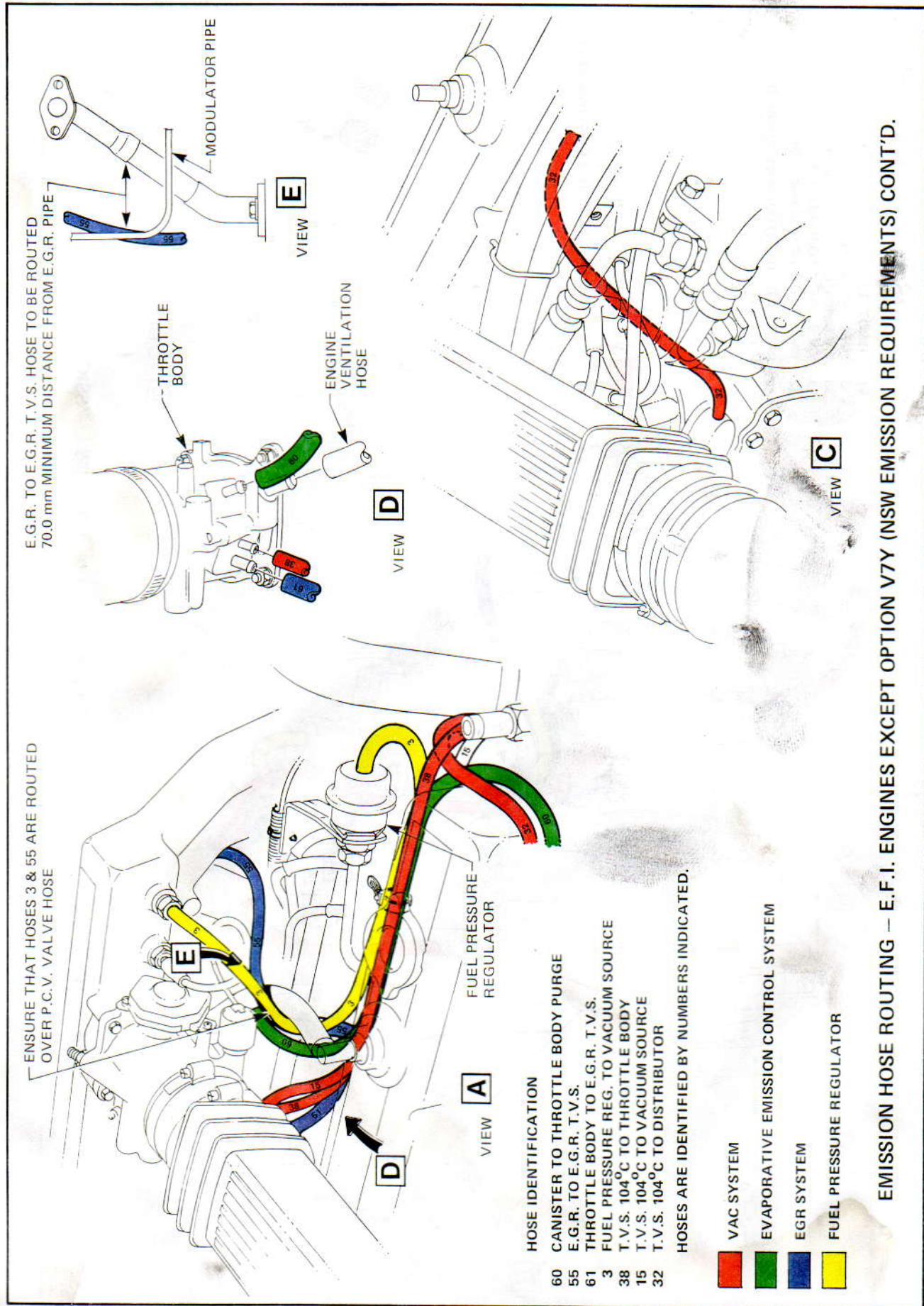

Figure 6E-7

1.4 VACUUM ADVANCE CONTROL

The ignition advance on engines with EST is electronically controlled, therefore no VAC system is used on these engines.

Engines with EFI (except those for registration in New South Wales) use a VAC system similar to VH with 3.3 engine and automatic transmission. The hose layout has been revised to suit the EFI installation. Refer Figs. 6E-6 and 6E-7 for hose routing details.

VAC SYSTEM (NSW)

The vacuum advance control system for 3.3 engines with EFI and production option V7Y (New South Wales emission requirements) differs in certain respects from the system meeting the national requirement. The following paragraphs refer to the V7Y type system.

Description

In addition to the high temperature (104°C) thermal vacuum switch in the thermostat housing, which is common to both VAC systems, the components specific to the VAC system for the V7Y option consists of:

- A low temperature (15°C) thermal vacuum switch located in the air flow duct and sensing the inlet air temperature.
- A medium temperature (40°C) thermal vacuum switch located in the engine block and sensing engine block metal temperature.
- The necessary vacuum hoses to connect the components. Refer Fig. 6E-8 for component layout.

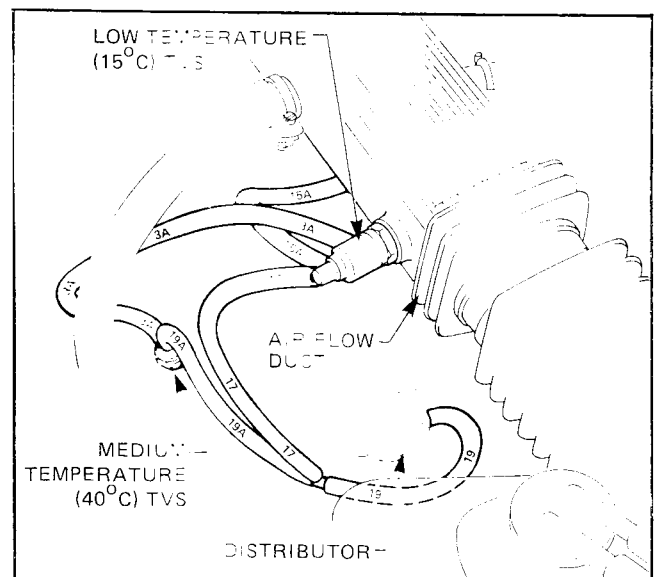

Figure 6E-8

Operation - Refer Fig. 6E-9

104°C Thermal Vacuum Switch

The 104°C thermal vacuum switch in the thermostat housing, senses engine coolant temperature. When coolant temperature is below 104°C, the TVS directs a ported vacuum signal from the throttle body to the centre port of the 15°C TVS located in the air flow duct. If coolant temperature exceeds 104°C, the 104°C TVS operates to direct full manifold vacuum (rather than ported vacuum) to the distributor and provides full vacuum advance at idle to prevent engine overheating.

6E-10 EMISSION CONTROL

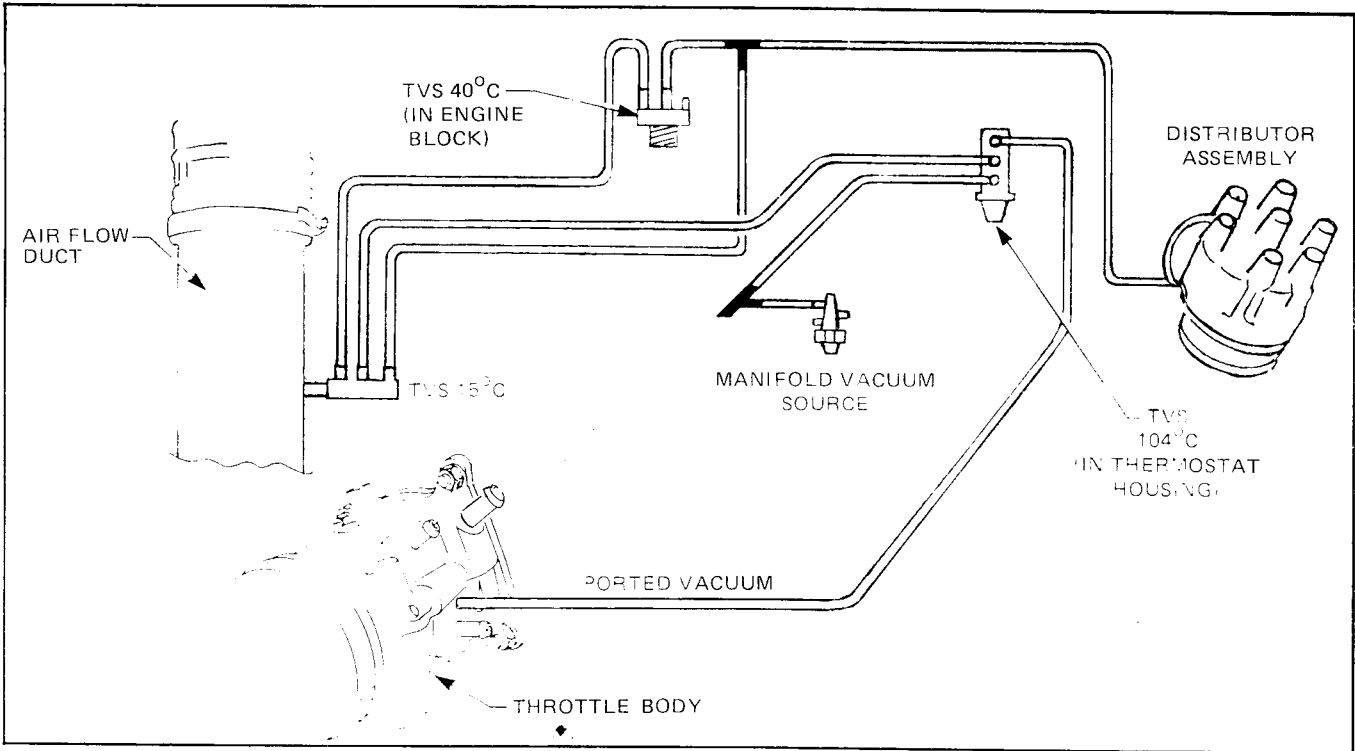

Figure 6E-9

15°C Thermal Vacuum Switch

The 15°C thermal vacuum switch in the air flow duct, senses inlet air temperature. When inlet air temperature is below 15°C, the ported vacuum signal is routed directly to the distributor, by-passing the 40°C TVS in the engine block. When the inlet air temperature is above 15°C, the 15°C TVS redirects the ported vacuum signal away from the distributor to the 40°C TVS in the cylinder block.

40°C Thermal Vacuum Switch

When the inlet air temperature exceeds 15°C, the ported vacuum signal is directed to the 40°C TVS via the 15°C TVS in the air flow duct. The 40°C TVS senses engine block temperature. When this temperature is below 40°C, the vacuum signal through the 40°C TVS is blocked and vacuum advance is denied. When engine metal temperature exceeds 40°C, the TVS 'opens' and the ported vacuum signal is directed to the distributor vacuum advance unit to permit vacuum advance.

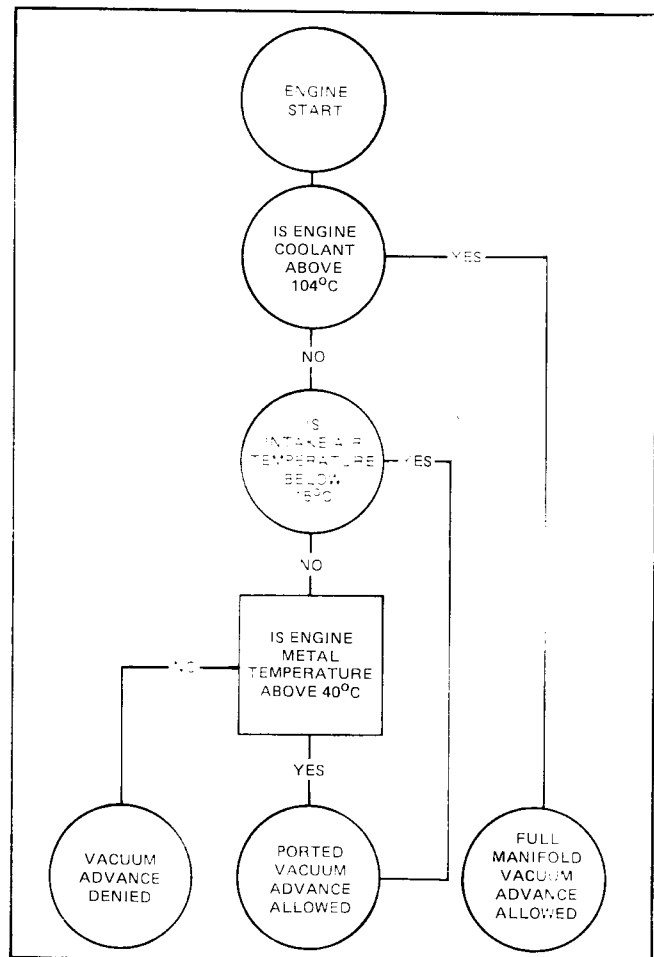

Figure 6E-10

Fig. 6E-10 summarizes the operation of the VAC system when production operation V7Y is excersided. Figs. 6E-11, 6E-12 and 6E-13 show the emission hose routing with V7Y.

HOSE IDENTIFICATION

- 60 CANISTER TO THROTTLE BODY PURGE
- 55 E.G.R. TO E.G.R. T.V.S.
- 61 THROTTLE BODY TO E.G.R. T.V.S.
- 3 FUEL PRESSURE REG. TO VACUUM SOURCE
- 38 T.V.S. 104°C TO THROTTLE BODY
- 15A T.V.S. 104°C TO 15°C T.V.S.
- 15 T.V.S. 104°C TO VACUUM SOURCE
- 3A T.V.S. 15°C TO T.V.S. 40°C
- 17 T.V.S. 15°C TO TEE

HOSES ARE IDENTIFIED BY NUMBERS INDICATED

- VAC SYSTEM
- EVAPORATIVE EMISSION CONTROL SYSTEM
- EGR SYSTEM
- FUEL PRESSURE REGULATOR

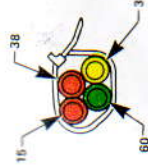

SECTION B-B

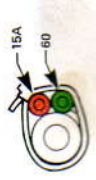
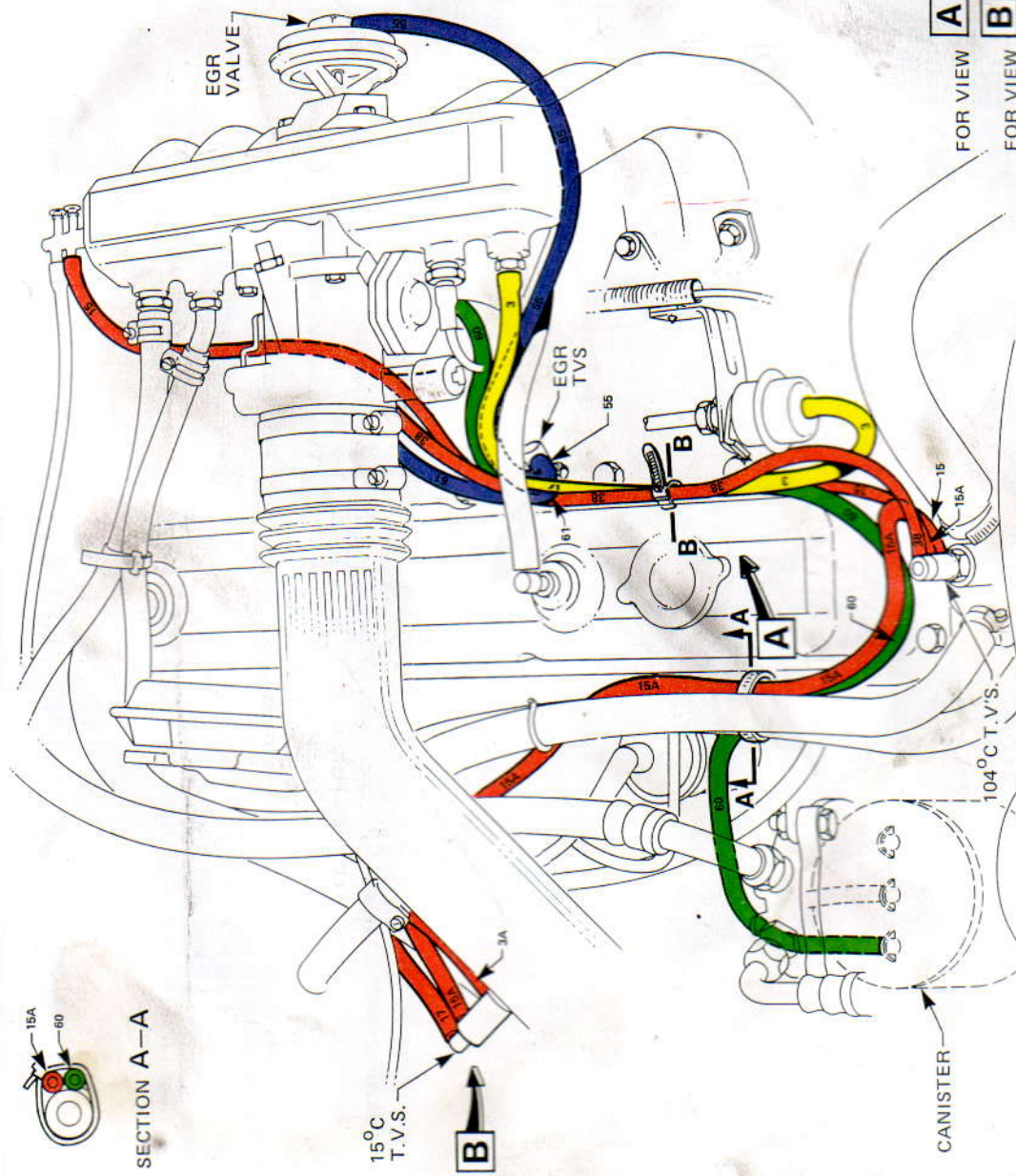

SECTION A-A

FOR VIEW **A** REFER 6E-12
 FOR VIEW **B** REFER 6E-13

EMISSION HOSE ROUTING — E.F.I. ENGINES WITH OPTION V7Y (NSW EMISSION REQUIREMENTS)

6E-12 EMISSION CONTROL

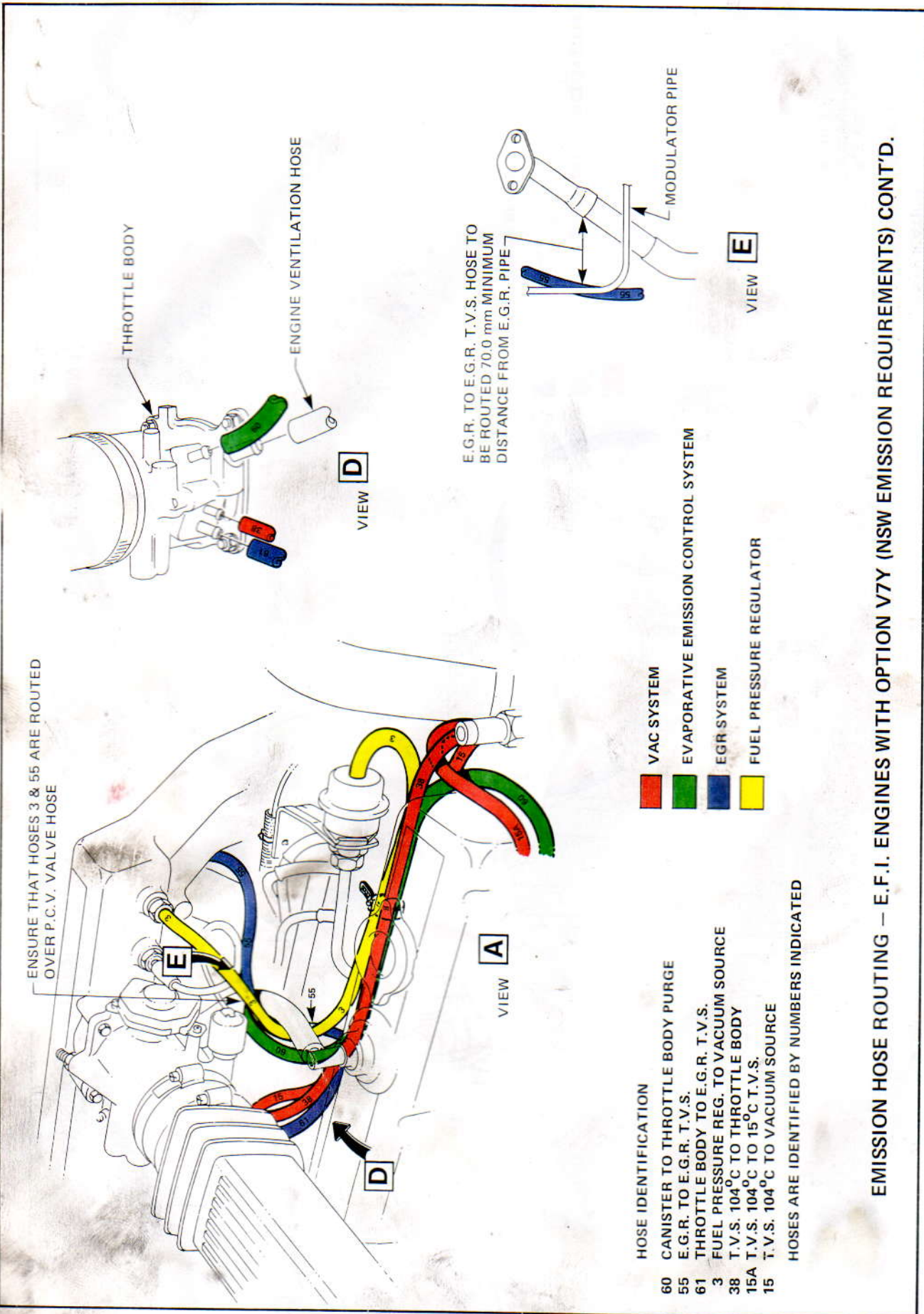

Figure 6E-12

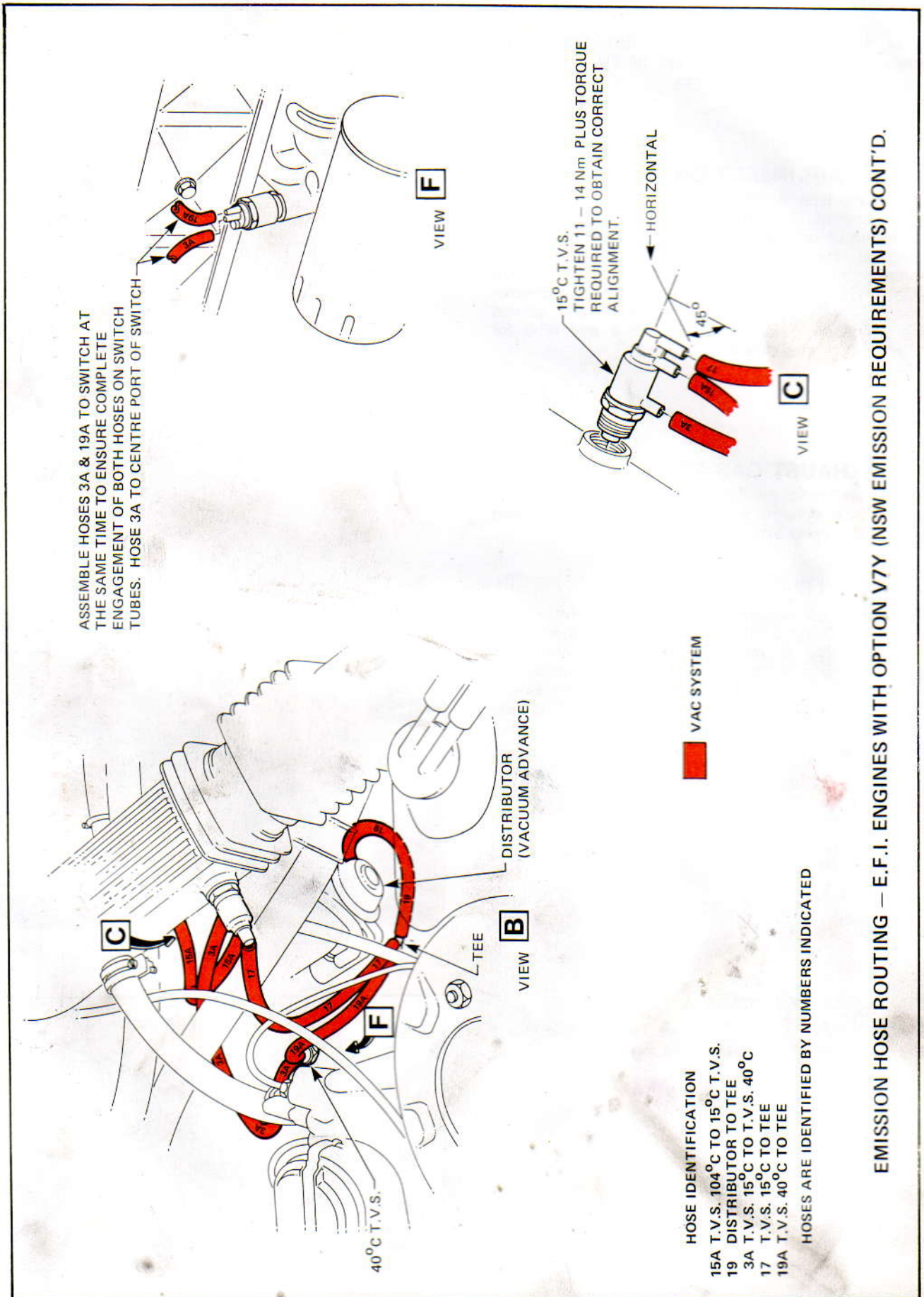

Figure 6E-13

6E-14 EMISSION CONTROL

1.5 AIR PREHEAT

The air preheat system for L6, 3.3 EST and 5.0 litre engines, carries over in general from the VH.

No air preheat is required with EFI.

1.6 AIR INJECTION REACTOR

The air pump type air injection reactor system is fitted to 3.3 EST engines. Six air pipes are balanced for air flow by inclusion of orifices specifically sized for each pipe and located at the cylinder head end. The system is essentially the same as used on VH with 2.8 litre engines. Refer Section 06, VH Service Manual Supplement M3873 for principles of operation and service operation details. Refer Figs. 6E-1, 6E-2 and 6E-3 for vacuum hose routing details.

1.7 EXHAUST GAS RECIRCULATION

The EGR system for the 5.0 litre engine carries over from VH. The EGR systems for 3.3 litre engines have been substantially revised over the VH type.

3.3 LITRE EFI ENGINES

The exhaust gas is directed to the EGR valve via an external pipe (Fig. 6E-14) to a port in the inlet manifold. The EGR valve is mounted on the inlet manifold, opposite the port (refer Fig. 6E-14). Ported vacuum is directed to the EGR valve via a thermal vacuum switch, refer Figs. 6E-6, 6E-7, 6E-11 and 6E-12 for EGR system hose layout.

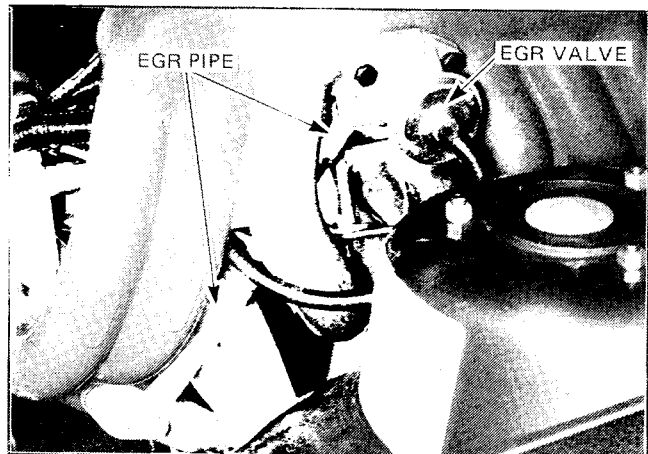

Figure 6E-14

3.3 LITRE EST ENGINES

The EGR system for EST engines has the EGR valve mounted on the inlet manifold (refer Fig. 6E-15).

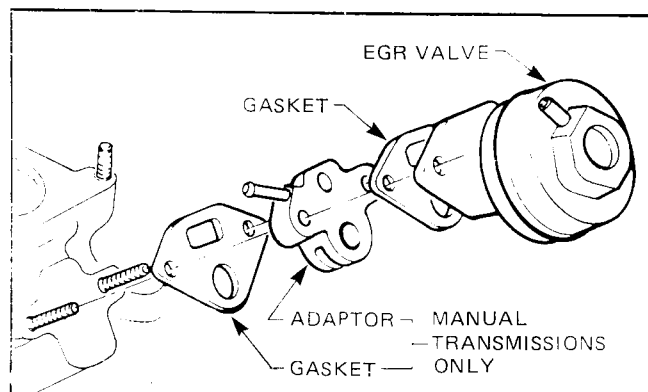

Figure 6E-15

Models with EST & Automatic Transmission

Ported vacuum is directed via a thermal vacuum switch to the EGR valve. Refer Fig. 6E-2 for hose layout.

Models with EST & Manual Transmissions

The EGR system for EST engines with manual transmissions incorporates an EGR modulator valve located in the vacuum line between the thermal vacuum switch and the EGR valve (refer Fig. 6E-16).

The purpose of the EGR modulator valve is to control the operation of the EGR valve so that the admission of exhaust gas into the combustion chamber is highest at times of potential high oxides of nitrogen emission generation.

Very little Oxides of nitrogen are generated at engine idle, light engine loads or on overrun. Oxides of nitrogen emission increases during acceleration.

As the throttle opens, a ported vacuum signal is routed through a thermal vacuum switch. The switch 'turns on' at 40°C to prevent exhaust gas recirculation when the engine is cold.

EGR valve operation is further regulated on EST engines and manual transmissions by the operation of the modulator valve.

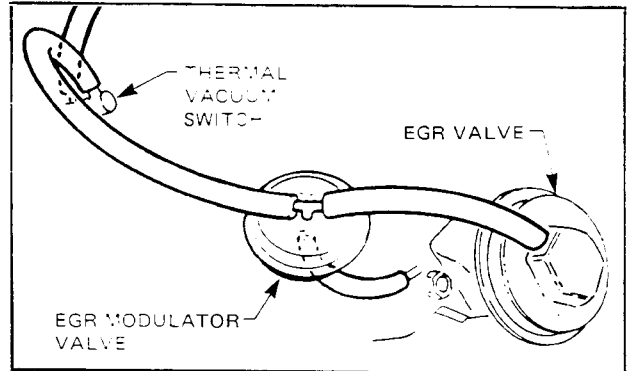

Figure 6E-16

EGR Modulator Valve Description

The modulator valve is a bleed type vacuum control device which uses exhaust gas pressure to control an air bleed within the valve and modulates the vacuum signal from the carburettor to the EGR valve according to engine load.

The valve (refer Fig. 6E-17) consists of two chambers separated by a diaphragm; the diaphragm has a seat at its centre. The centre tube of the tee piece is retained in the upper chamber which is vented to atmosphere via a filter.

The two exposed branches of the tee piece each contain a restricting orifice. One branch is connected to the vacuum line from the carburettor and TVS and the other to the vacuum chamber of the EGR valve.

The purpose for the restrictors is to damp any pulsations in the vacuum signal from the manifold and help control EGR valve response to rapid changes in exhaust gas pressure.

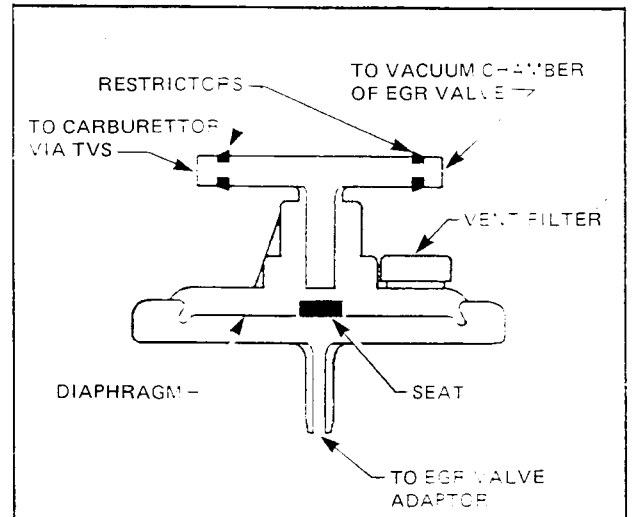

Figure 6E-17

The lower chamber of the valve is exposed to exhaust gas pressure via a hose from an adaptor located between the EGR valve and inlet manifold (refer Fig. 6E-18).

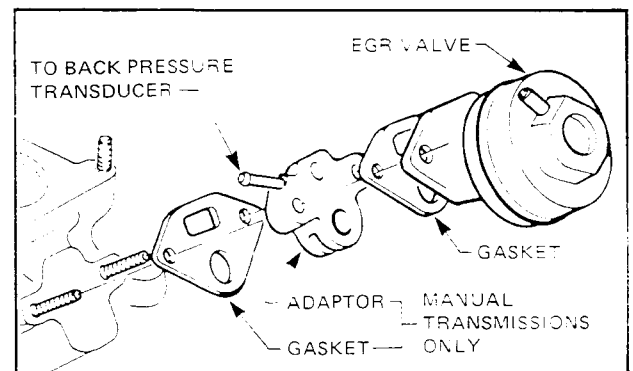

Figure 6E-18

6E-16 EMISSION CONTROL

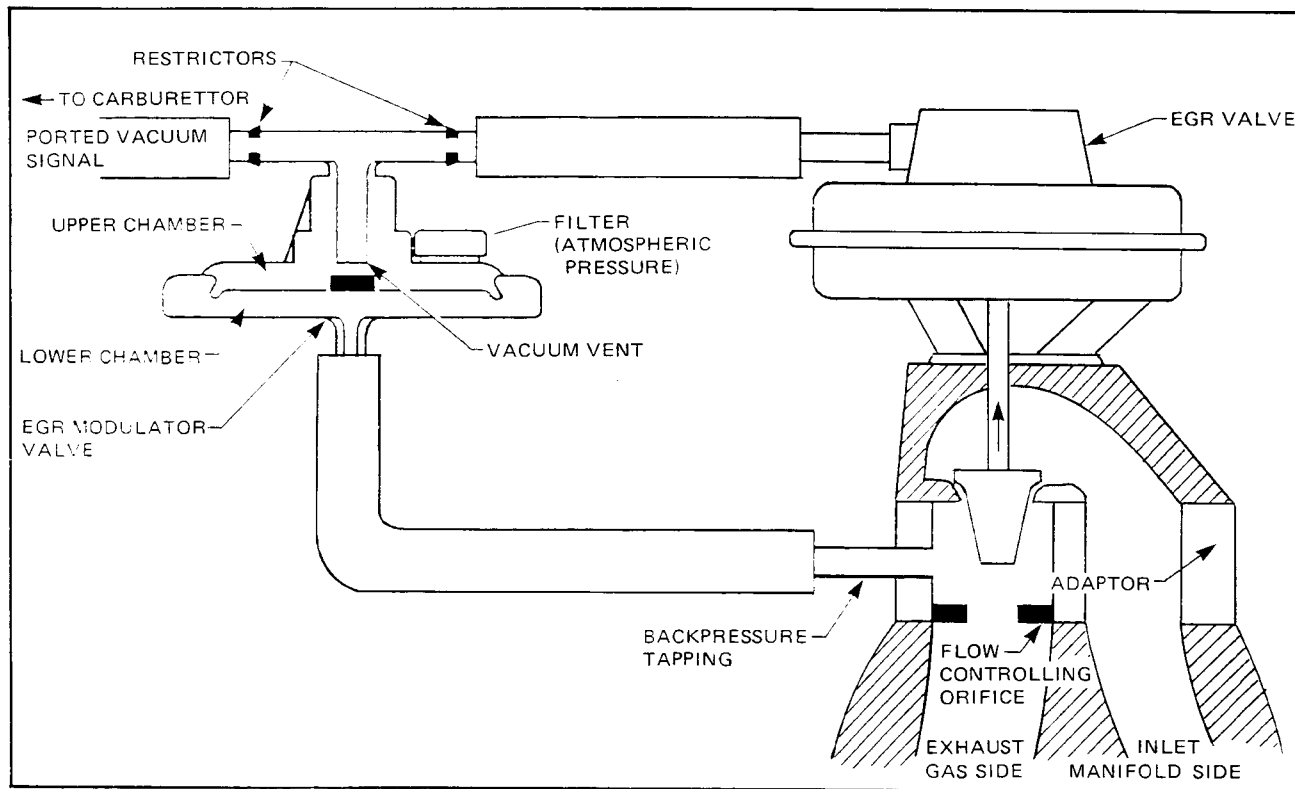

Figure 6E-19

EGR Modulator Valve Operation (Refer Fig. 6E-19)

With low exhaust back pressure in the valve lower chamber, the vacuum line is vented to atmosphere via the centre branch of the tee and filter. The EGR valve remains closed and no recirculation takes place.

As exhaust back pressure increases during acceleration or under load, the pressure on the diaphragm also increases, the diaphragm moves the diaphragm seat and restricts the venting of the vacuum line. This results in vacuum being applied to the vacuum chamber of the EGR valve, the EGR valve opens and recirculation commences. As engine load, (reflected in the value of exhaust back pressure) increases, the venting of the vacuum signal decreases, applying more vacuum to the EGR valve vacuum chamber, permitting the EGR valve to open further and admit more exhaust gas into the induction system.

As engine load decreases, exhaust pressure decreases, diaphragm force decreases, vacuum signal venting increases and the EGR valve reduces the amount of exhaust gas being recirculated. The valve therefore modulates the vacuum signal to the EGR valve to make EGR valve operation sensitive to engine load.

1.8 THROTTLE NUDGER

Vehicles with 3.3 EST engine and manual transmissions are fitted with a throttle nudger similar to that used on VH with the 2.8 litre engine and manual transmission. Refer Section 06, VH Service Manual Supplement M38731 for description and operation. Refer Fig. 6E-1 for throttle nudger hose routing.

2. SERVICE OPERATIONS

2.1 GENERAL INFORMATION

Service operations for emission system components carry over in general from VH Series vehicles.

Service procedures for the following components are covered in Section 09 'Emission Control Systems' of the Improved Performance Engine Service Manual part number M38338.

- EGR Thermal Vacuum Switch Testing and Replacement.
- EGR Valve Checking, Cleaning and Replacement.
- EFE Thermal Vacuum Switch and Actuator Testing and Replacement.
- Air Preheat System Testing.
- VAC System Testing.
- Positive Crankcase Ventilation System Testing and Servicing.
- Evaporative Emission Control System Servicing.

Service procedures for the Air Pump and Throttle Nudger are covered in Section 06 'Emission Control' of the VH Series Manual Supplement part number M38731.

The following service operation is new for VK series vehicles.

2.2 EGR MODULATOR VALVE

TEST

1. Disconnect all hoses from the EGR modulator valve and remove valve.
2. Install a vacuum source such as hand pump J23987-01 or equivalent to the bottom valve port.
3. Operate the vacuum pump, and it should be possible to draw a vacuum on the valve diaphragm. If a vacuum is not drawn, the valve diaphragm is defective and the valve must be replaced.
4. Connect the vacuum pump to one side of the 'T' piece on top of the valve, plug the opposite end of the 'T' piece with a suitable plug.
5. Operate the vacuum pump and it should not be possible to draw a vacuum. This indicates that the valve fitter is operating correctly. If a vacuum is drawn, the fitter is defective and the valve must be replaced.

SECTION 6F

ENGINE TUNE

INDEX

Ref.	Subject	Page	Ref.	Subject	Page
1.	GENERAL INFORMATION	6F-1	3.2	3.3 LITRE EFI	6F-4
2.	ENGINE TUNE RECOMMENDATIONS	6F-2		Tune Conditions	6F-4
3.	ENGINE TUNE DATA	6F-3	3.3	5.0 LITRE	6F-4
3.1	3.3 LITRE EST	6F-3			
	Tune Conditions	6F-3			
	Check List	6F-3			

1. GENERAL INFORMATION

To maintain designed vehicle performance and emission levels, it is recommended that regular maintenance and adjustments be carried out in accordance with the schedule outlined in the VK Series Owner Handbook.

Engine tune specifications necessary to achieve the correct emission levels are located on the Vehicle Emission Control Information Label attached to the right hand suspension strut tower under the engine hood. The label should be referred to before making any adjustments.

The Engine Tune Recommendations chart sets out the items recommended for attention during an engine tune and cross reference is provided to the appropriate source of information. The Engine Tune Data charts (refer 3.1, 3.2 and 3.3 in this Section), provide abridged engine tuning data for both 3.3 litre and 5.0 litre engines.

6F-2 ENGINE TUNE

2. ENGINE TUNE RECOMMENDATIONS

ENGINE TUNE RECOMMENDATIONS		REFERENCE
Engine Compression	Test	Section 10, "Engine Tune Up" of the Improved Performance Engine Service Manual P/N M38338. For EFI vehicles, also refer Section 6C Electronic Fuel Injection, Service Note 9, of this Supplement.
Engine Drive Belts	Check and adjust as necessary.	Section 6, "Cooling Systems" of the VH Series Service Manual Supplement P/N M38731.
Cooling Systems	Check system for leaks.	Section 6, "Cooling Systems" of the VB Series Service Manual P/N M38145.
Idle Speed	Check and adjust as necessary.	3.3 Litre EST. Section 6C, "Carburettors" of this Supplement. 3.3 Litre EFI. Section 6C, "Electronic Fuel Injection," of this Supplement. 5.0 Litre. Section 5, "Engine Fuel Systems," of the Improved Performance Engine Service Manual. Refer to specifications on the emission control label on the right hand strut tower.
Automatic Choke	Check settings and linkage.	3.3 Litre EST. Section 6C, "Carburettors" of this Supplement. 5.0 Litre. Section 5, "Engine Fuel Systems" of the Improved Performance Engine Service Manual.
Air Filter Element	Check or replace.	Section 10, "Engine Tune Up" of the Improved Performance Engine Service Manual. For EFI engines, also refer Section 6C "Electronic Fuel Injection" instruction 3.5 of this Supplement.
Valve Lash Adjustment	Non adjustable hydraulic lash adjusters.	
In-line Fuel Filter	Check or replace.	3.3 Litre EST. Section 10, "Engine Tune Up" of the Improved Performance Engine Service Manual. 3.3 Litre EFI. Section 6C, "Electronic Fuel Injection," of this Supplement.
Spark Plugs	Clean, adjust or replace.	Section 10, "Engine Tune Up" of the Improved Performance Engine Service Manual.
Ignition Timing	Check and reset as necessary.	Section 6D, "Ignition System" Specifications of this Supplement.
Ignition High Tension Cables	Test.	Section 10, "Engine Tune Up" of the Improved Performance Engine Service Manual.
Throttle Nudger (EST manual only)	Check and reset as necessary.	Section 6, "Emission Control" of the VH Series Service Manual Supplement.
EGR Valve Air Preheat System Engine Ventilation System Evaporative Emissions Systems	Check for correct operation. Replace canister filter at specified interval.	Section 9, "Emission Control Systems" of the Improved Performance Engine Service Manual.
Battery and Cables	Check.	Section 12, "Electrical Section" of the VB Series Service Manual and Section 12A "Battery and Cables of this Supplement.
Electronic Fuel Injection, Component Hoses	Check all hoses and connectors for air leaks. Check and rectify as necessary.	
Throttle Position Switch (EST models only)	Check for correct operation.	Section 6D, "Ignition System" service operation 2.7 of this Supplement.

3. ENGINE TUNE DATA

3.1 3.3 LITRE EST

ENGINE		TRANSMISSION	IDLE SPEED RPM (IN NEUTRAL)	FAST IDLE SPEED	SPARK ADV. BELOW 900 RPM	SPARK PLUGS	
SIZE	OPTION					TYPE	GAP
3.3 Litre HC	EST (L14)	Manual or Automatic	850 ± 25	1150 ± 25	Preset visual Check only 6° ± 4°	AC C42CLTSX	1.5 ± $\frac{0.1}{0.2}$ mm

NOTE: Carburettor is not to be adjusted prior to 1500 km service. Only the idle speed may be adjusted from 1500 kms onwards.

Prior to making any carburettor idle adjustments, refer to Section 6C, Carburettor of this Supplement.

TUNE CONDITIONS

Before making any checks or adjustments, warm the engine by running for 6 minutes with transmission in neutral and fast idle screw on second step of fast idle cam, refer Fig. 6F-1, or running for 10 minutes at 80 km/hr on a chassis dynamometer.

Switch ignition off, restart vehicle with transmission in neutral. Check engine tune specifications.

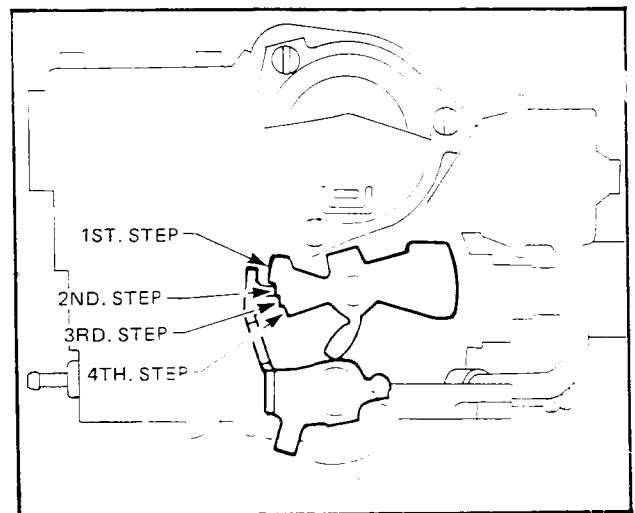

Figure 6F-1

CHECK LIST

- (A) Engine idle speed exceeds 880 rpm.
1. Check that engine has been running 15 minutes.
 2. Check that throttle closes onto stop. Ensure that the throttle nudger, choke and throttle cable are correctly adjusted to allow the throttle to close onto stop.
 3. Check that throttle position switch is closed.
 4. Check that advance at idle is less than 10° BTDC.
- (B) Engine idle speed is less than 700 rpm.
1. Check engine has been running 15 minutes.
 2. Check power to anti-dieseling solenoid.
 3. Check PCV valve for flow.
 4. Check for vacuum leaks.
 5. Check for greater than 2° BTDC advance.

6F-4 ENGINE TUNE

3.2 3.3 LITRE EFI

ENGINE		IDLE SPEED RPM RUN IN ENGINE	IDLE CO %	DISTRIBUTOR ADVANCE BTDC * RPM	SPARK PLUGS	
SIZE	OPTION				GAP	TYPE
3300	EFI (LL9)	850 ± 50	.5 - 1.5	12° BELOW 1100	1.5 ± $\frac{.05}{.05}$ mm	AC C42CLTSX

TUNE CONDITIONS

Engine tune settings are for an engine with:-

1. Engine coolant and oil at normal operating temperature, preferably achieved by driving (both CO and idle speed are dependant on engine temperature).
2. Transmission in park or neutral.
3. Air conditioning switched off.

The following checks must be performed and any defects corrected before any idle adjustments are made to the EFI system.

1. Ignition timing.
2. Vacuum to fuel pressure regulator.
3. Throttle lever closing on to stop - if not check:
 - a. Throttle position switch adjustment.
 - b. Linkage and springs.
4. No leaks at hoses and duct between air flow meter and engine.
5. Running on all cylinders - if not check for
 - a. Defective spark plugs and leaks.
 - b. Open circuit to injector/s.
6. Auxiliary air valve fully shut - check by pinching off air hose and observing engine speed. If speed drops check for:
 - a. Engine not sufficiently warmed up.
 - b. Open circuit in electrical supply to auxiliary air valve.
 - c. Auxiliary air valve on upside down.

NOTE: Before adjusting the idle speed, disconnect the canister purge hose from the canister and then adjust idle speed. Refer to service operation 3.5, Section 6C, of this Supplement.

3.3 5.0 LITRE

ENGINE				IDLE SPEED RPM		DISTRIBUTOR	SPARK PLUGS	
SIZE	COMP.	TRANS.	PROD. OPTION	SLOW	FAST	INITIAL ADVANCE BTDC @ RPM	GAP mm	TYPE
5.0	HC	MAN. AUTO.	L31	850 650D	1500 2nd HIGHEST STEP	6° BTDC @ 850 RPM	1.5	44TX

* VACUUM ADVANCE HOSE DISCONNECTED AND PLUGGED

For 5.0 litre Tune Conditions refer to Section 6 Engine Tune of the VH Series Service Manual Supplement.

Engine Tune Specifications are on the Emission Control label on the right hand suspension strut tower.

SECTION 7A

CLUTCH

INDEX

Ref.	Subject	Page	Ref.	Subject	Page
1.	GENERAL DESCRIPTION	7A-1	2.	SERVICE OPERATIONS	7A-1

1. GENERAL DESCRIPTION

The clutch assembly used on VK Series models is carried over from the VH Series.

2. SERVICE OPERATIONS

For clutch adjustment details refer Figs. 7A-1 and 7A-2.
 For all service operations refer Section 7 of the VB Commodore Service Manual, Part No. M38145.

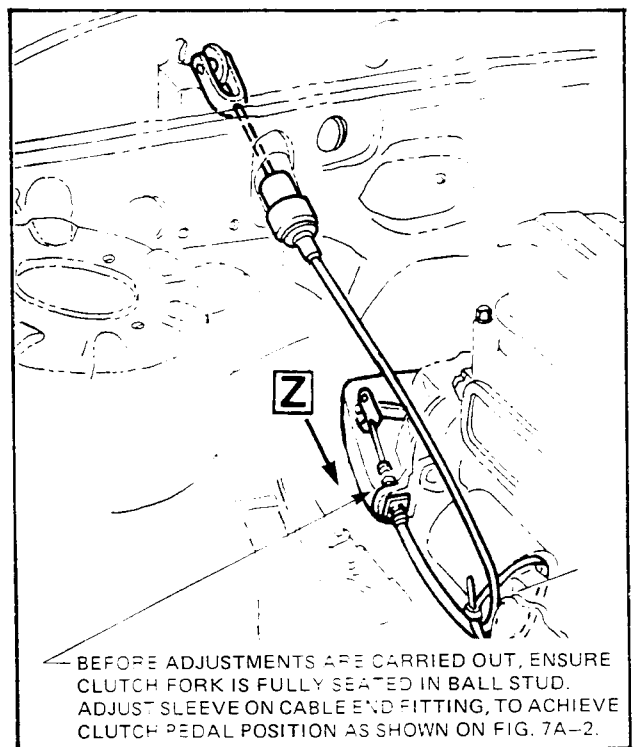

Figure 7A-1

To adjust clutch cable, lightly load clutch fork in direction of arrow Z, refer Fig. 7A-1, so that throwout bearing contacts clutch spring fingers. Then using cable adjusting sleeve set clutch pedal to correct height with rubber trim pad removed from pedal.

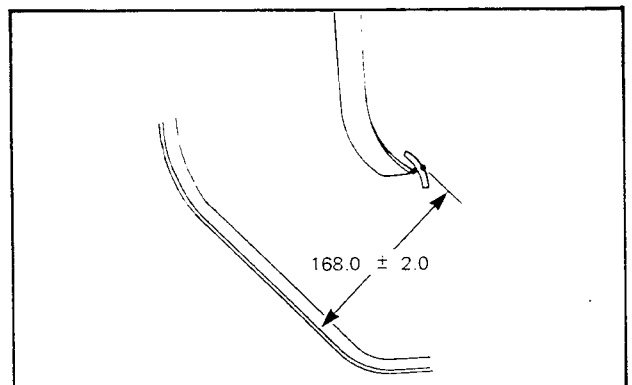

Figure 7A-2

SECTION 7B

MANUAL TRANSMISSION

INDEX

Ref.	Subject	Page	Ref.	Subject	Page
1.	GENERAL DESCRIPTION	7B-1	2.1	TORQUEMASTER.....	7B-2
2.	SERVICE OPERATIONS	7B-2	2.2	BORG WARNER (5-SPEED).....	7B-2

1. GENERAL DESCRIPTION

The Torquemaster four speed manual transmission is standard equipment on VK Series SL 19 and 35 styles with the 3.3 litre EST engine.

The Borg Warger five speed manual transmission is available as a production option on vehicles with the 3.3 litre EST engine. Transmissions for 3.3 EST engine application, carry the code BE stencilled in yellow paint on the left hand side of the transmission case.

Revisions introduced for code BE transmissions are:-

1. GEARS: stress relieved by shot peening.
2. 5TH SPEED MAINSHAFT GEAR: needle roller bearing has been deleted (refer Fig. 7B-1). The gear now rotates on a revised bearing surface on the mainshaft.
3. GEAR RATIOS:

1ST	3.23 : 1
2ND	1.96 : 1
3RD	1.26 : 1
4TH	1.00 : 1
5TH	0.78 : 1
REVERSE	3.36 : 1

The following chart sets out manual transmission application for VK Series models.

ENGINE	TRANSMISSION	MODEL		
		SL	BERLINA	CALAIS
Body Style		19 35	19 35	19
3.3 litre EST	Torquemaster (3.50:1 1st gear)	S S	C C	N/A
3.3 litre EST	Borg Warner (5 speed)	O O	C C	N/A

S Standard Equipment
 N/A Not Available
 O Available as Production Option

NOTE: Manual transmissions are not available if an engine is equipped with Electronic Fuel Injection.

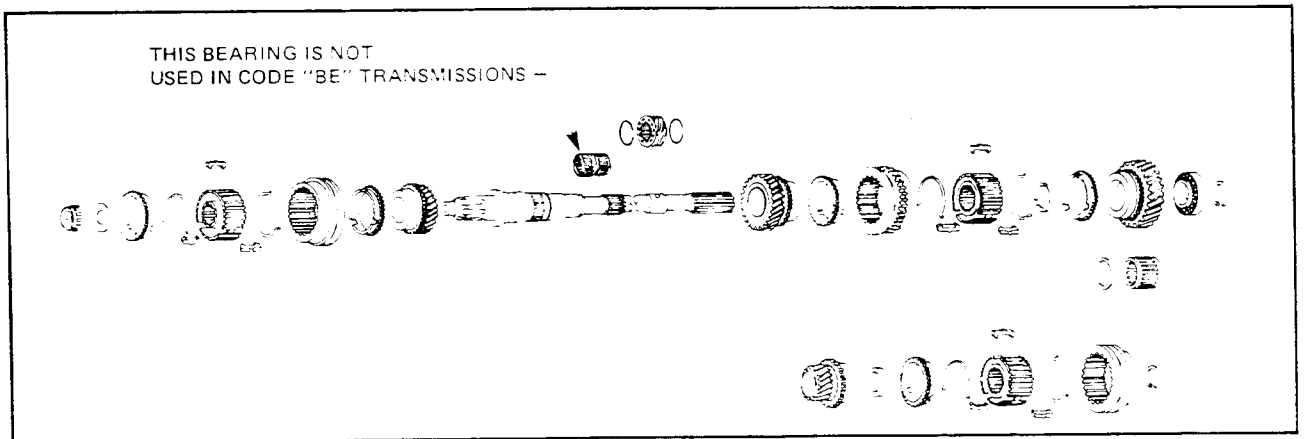

Figure 7B-1

7B-2 MANUAL TRANSMISSION

2. SERVICE OPERATIONS

NOTE: Before removing any manual transmission, the EST speed sensor must be removed from the rear of the cylinder block. Refer to Service Instruction 2.8, Section 6D, Ignition System, of this Supplement.

2.1 TORQUEMASTER

For removal and installation instructions refer to Section 07 of the VB Commodore Service Manual Part No. M38145.

For overhaul procedures refer to the Torquemaster Service Manual, Part No. 92010388, and Torquemaster Service Manual Supplement, Part No. M39043.

2.2 BORG WARNER (5-SPEED)

For all service operations refer to the Holden Commodore Five Speed Manual Transmission Service Manual, Part No. M39071.

SECTION 7C

AUTOMATIC TRANSMISSION

INDEX

Ref.	Subject	Page	Ref.	Subject	Page
1.	GENERAL DESCRIPTION	7C-1	1.12	BAND ADJUSTMENT	7C-5
1.1	TRANSMISSION CODES	7C-1	1.13	THIRD CLUTCH ASSEMBLY	7C-5
1.2	1-2 & 2-3 SHIFT CONTROL VALVES AND SLEEVES	7C-2	1.14	SECOND CLUTCH DUMP BALL	7C-6
1.3	1-2 & 2-3 SHIFT VALVES	7C-2	1.15	PRESSURE REGULATOR BOOST VALVE AND SLEEVE	7C-6
1.4	MANUAL VALVE	7C-3	2.	TRANSMISSION SHIFT SPEED CHART	7C-13
1.5	LOW SPEED TIMING VALVE	7C-3	3.	TRIMATIC TRANSMISSION SPRING IDENTIFICATION CHARTS	7C-14
1.6	1-2 ACCUMULATOR CONTROL VALVE	7C-3	3.1	CODE LP (3.3 LITRE EST ENGINE)	7C-14
1.7	ACCUMULATOR PISTON PIN	7C-3	3.2	CODE LR (3.3 LITRE EFI ENGINE)	7C-14
1.8	TRANSFER PLATE	7C-4	3.3	CODE LS (5.0 LITRE ENGINE)	7C-15
1.9	SERVO PISTON	7C-4	4.	LINE PRESSURE SPECIFICATION CHART	7C-15
1.10	VALVE BODY IDENTIFICATION	7C-4	5.	SPECIFICATIONS	7C-16
1.11	VACUUM MODULATOR VALVE AND SLEEVE	7C-4			

1. GENERAL DESCRIPTION

The Trimatic Automatic Transmission is standard equipment for VK Series on Berlina and Calais. Trimatic is available as an option on all other VK Series models with the 3.3 litre EST, 3.3 litre EFI or 5.0 litre engines.

Carryover of the Trimatic to the above 3.3 litre engines has necessitated the release of new Trimatic transmission codes.

Transmission codes LP, 3.3 litre EST, and LR, 3.3 litre EFI, are the same as transmission code FP, 3.3 litre VH, except where noted in this Section.

LP Code incorporates the earlier design 'open' converter housing and LR code uses the carryover 'full circle' converter housing design.

Transmission code LS, 5.0 litre, carries over from 5.0 litre VH models and WB Statesman.

The following paragraphs set out the calibration details for each of the new transmission codes.

1.1 TRANSMISSION CODES

The transmission identification plate carries the transmission serial number and application code. The following codes are used with VK Series Trimatic transmission.

TRANSMISSION CODE	ENGINE
LP	3.3 litre equipped with EST
LR	3.3 litre equipped with EFI
LS	5.0 litre

7C-2 AUTOMATIC TRANSMISSION

1.2 1-2 & 2-3 SHIFT CONTROL VALVES AND SLEEVES

All three transmissions use the same 1-2 and 2-3 shift control valves. Identification is by a ring around the valve refer Fig. 7C-1 for 1-2 shift control valve identification.

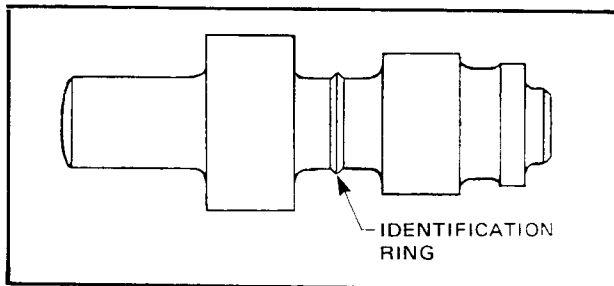

Figure 7C-1

For 2-3 shift control valve identification refer Fig. 7C-2.

The three transmissions also use the same 1-2 and 2-3 control valve sleeves.

The 1-2 control valve sleeve is identified by a green colour marking on the open end of the sleeve.

The 2-3 control valve sleeve has no colour marking on the open end of the sleeve.

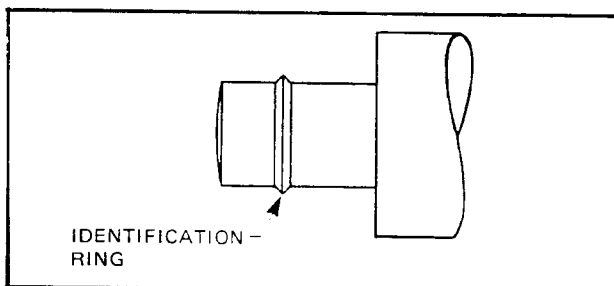

Figure 7C-2

1.3 1-2 & 2-3 SHIFT VALVES

All three transmissions use the same 1-2 and 2-3 shift valves.

The 1-2 shift valve is identified by a hole drilled in the end of the valve. Refer Fig. 7C-3).

This hole has a 1-2 shift valve spring inserted, which assists governor pressure to reduce the road speed at which the light throttle 1-2 upshifts occur.

This valve is not interchangeable with the Series 3 shift valve.

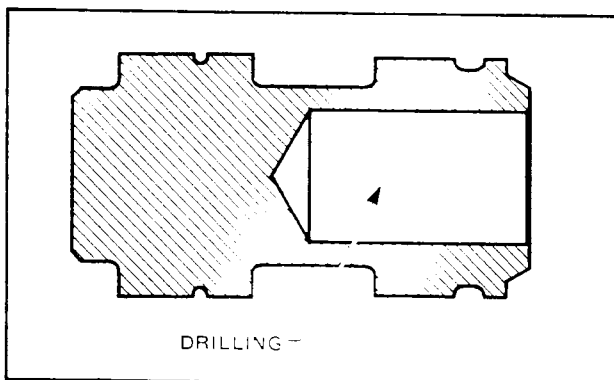

Figure 7C-3

The 2-3 shift valve is identified by a ring around the centre of the valve stem (refer Fig. 7C-4).

This valve is not interchangeable with the Series 3 shift valve.

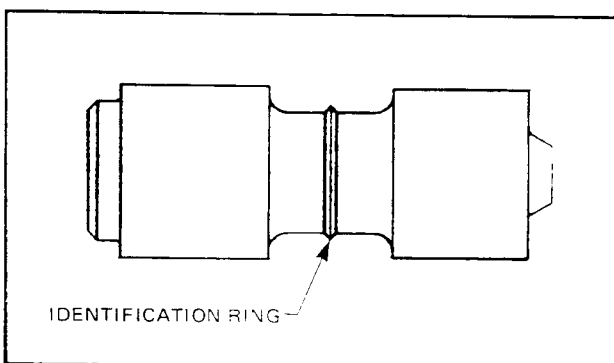

Figure 7C-4

1.4 MANUAL VALVE

A modified manual valve is used with LS code transmissions.

It incorporates an end drilling with 2 bleed holes (refer Fig. 7C-5). The modifications to the manual valve improve the shift quality from drive into neutral range.

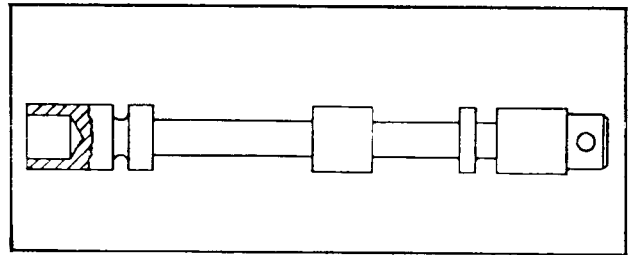

Figure 7C-5

1.5 LOW SPEED TIMING VALVE

The low speed timing valve in codes LR and LS transmissions has been revised. The overall length of the valve has been decreased from 48.64-48.90 to 43.5-43.8 mm (refer Fig. 7C-6).

This is to allow the inclusion of a low speed timing control valve and sleeve.

For details of the low speed timing valve and control valve operation, refer to page 40 of the Service Manual 'Trumatic Principles of Operation' Part No. M37823.

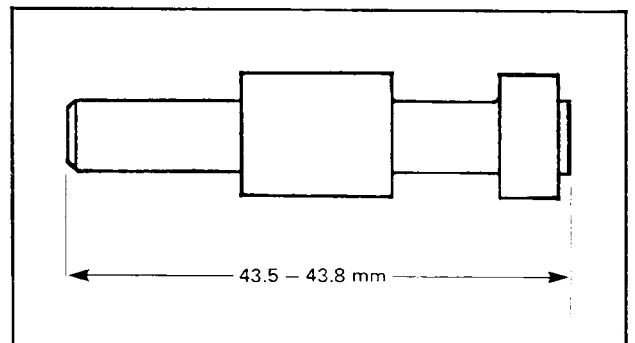

Figure 7C-6

1.6 1-2 ACCUMULATOR CONTROL VALVE

All three new code transmissions use a common 1-2 accumulator control valve.

The diameter of the spool section of the valve has been increased from 8.705-8.712 mm to 11.079-11.087 mm (refer Fig. 7C-7).

This valve is not interchangeable with the Series 3 control valve.

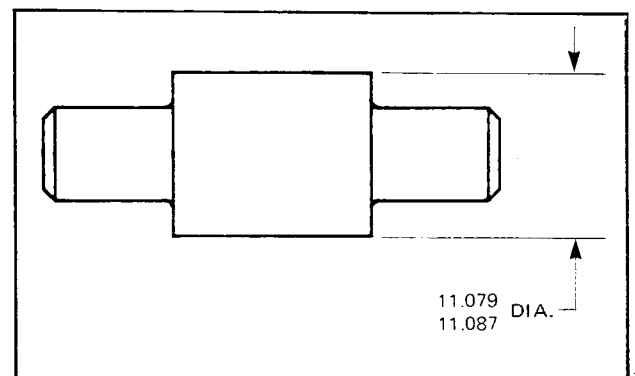

Figure 7C-7

1.7 ACCUMULATOR PISTON PIN

The accumulator piston pin on all three transmissions has been increased in length from 43.2 mm to 44.2 mm (refer Fig. 7C-8).

The accumulator piston spring has been deleted from the three transmissions.

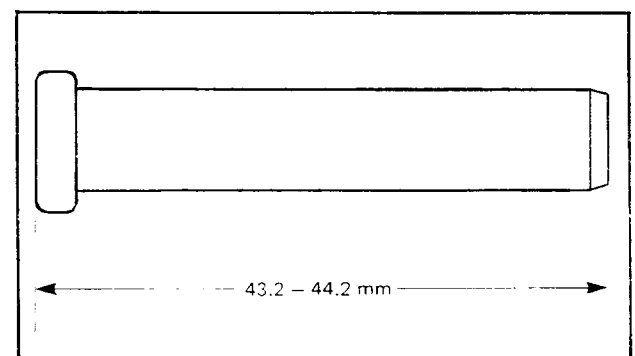

Figure 7C-8

7C-4 AUTOMATIC TRANSMISSION

1.8 TRANSFER PLATE

Transfer plates are identified by their part number stamped in the area shown in Fig. 7C-9.

TRANSFER PLATE PART NUMBER	APPLICATION
92017838	LP
92009405	LR
92021278	LS

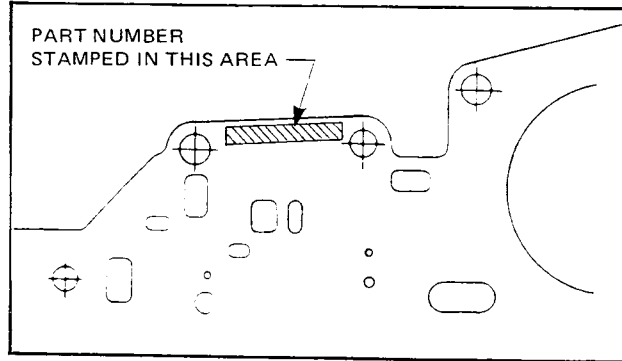

Figure 7C-9

1.9 SERVO PISTON

For identification details of the servo piston used in all three transmissions, refer Fig. 7C-10.

The servo piston is the same in all three transmissions but the servo cushion springs differ. Refer to Spring Identification Charts in this Section for cushion spring identification.

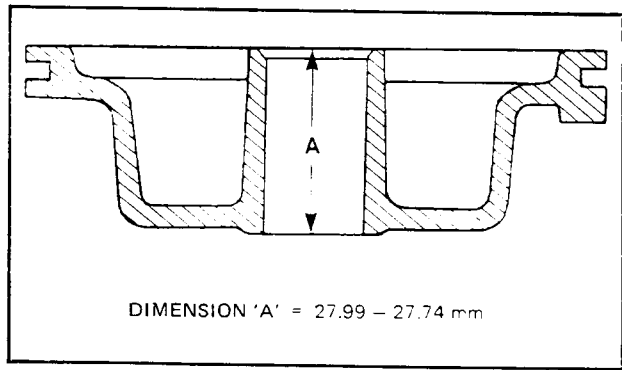

Figure 7C-10

1.10 VALVE BODY IDENTIFICATION

The valve body for each transmission carries three digits followed by the calibration alpha letter stamped on the underside of the body, adjacent to the accumulator piston pin (refer Fig. 7C-11).

TRANSMISSION CODE	
LP	828 *
LR	837 *
LS	590 *

calibration
* alpha character

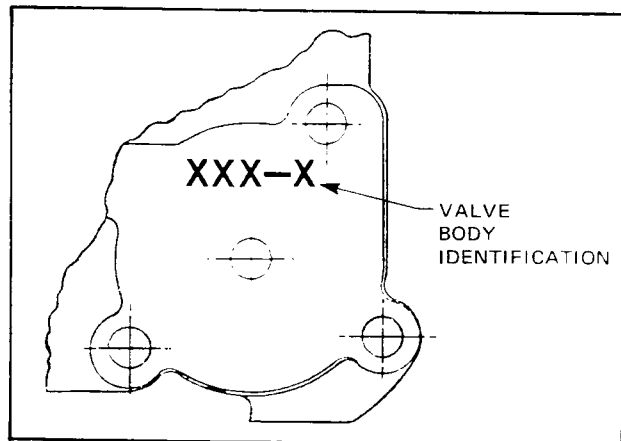

Figure 7C-11

1.11 VACUUM MODULATOR VALVE AND SLEEVE

All three transmissions use the same vacuum modulator valve and sleeve.

Valve identification is by a ring around the valve stem as shown in Fig. 7C-12.

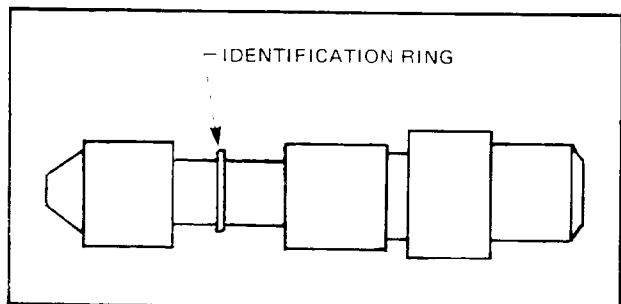

Figure 7C-12

AUTOMATIC TRANSMISSION 7C-5

The vacuum modulator sleeve is identified by the length of the sleeve, Fig. 7C-13, and a blue colour marking on the closed end.

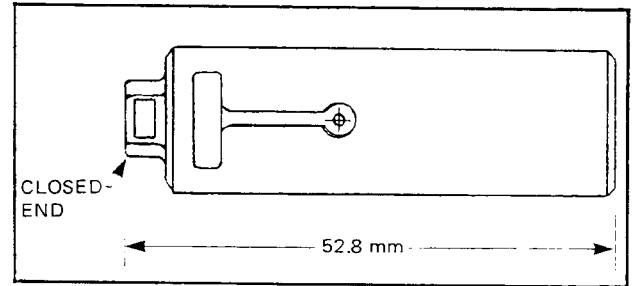

Figure 7C-13

1.12 BAND ADJUSTMENT

The correct band adjustment procedure is as follows:

1. Remove oil pan and servo cover, loosen adjusting screw lock nut.
2. Using Tool No. 7AT4 and a torque wrench, tighten adjusting screw to 4.5 Nm then back off screw.

TRANSMISSION CODE		TURNS BACKED OFF
LP		5
LR		5
LS		5

3. Tighten lock nut and install servo cover and oil pan. Refill transmission with Dexron II Automatic Transmission Fluid.

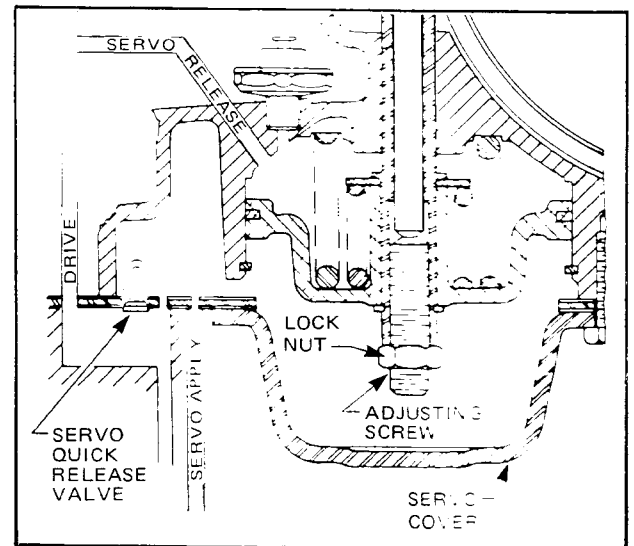

Figure 7C-14

1.13 THIRD CLUTCH ASSEMBLY

The third clutch assembly for code LS transmissions differs from that used in the six cylinder codes.

Revisions have been made to the clutch piston return springs and spring retainer.

Dimensions for third clutch return springs are as follows:

TRANSMISSION CODE	LP & LR	LS
Free Length	26.97 mm	29.13 mm
Total Coils	8.75	11
Diameter	10.9 mm	11 mm

For identification of the LS return spring retainer, refer Fig. 7C-15.

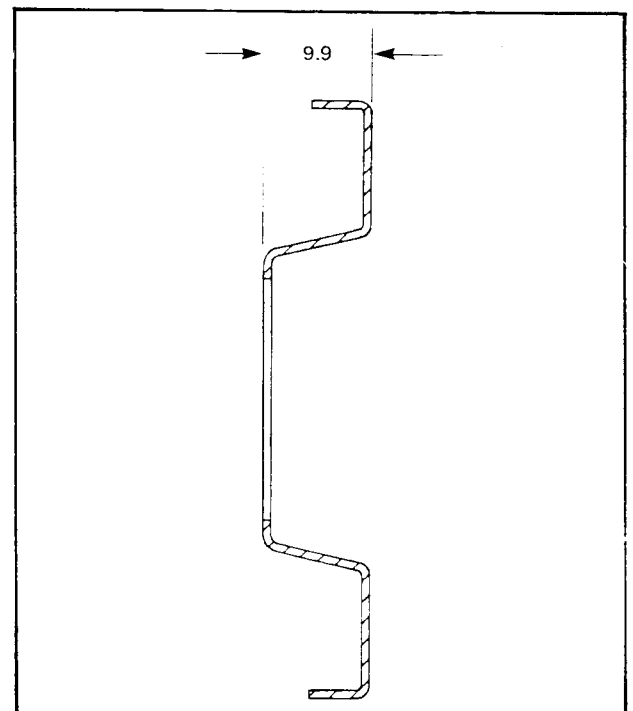

Figure 7C-15

7C-6 AUTOMATIC TRANSMISSION

1.14 SECOND CLUTCH DUMP BALL

Code LS transmissions have incorporated a dump ball in the second clutch circuit.

When the second clutch is being applied, second clutch oil seats the ball and the feed is directed through an orifice. During the release of the clutch, the ball is unseated and the clutch can exhaust at a faster rate through the two orifices. Refer Fig. 7C-16.

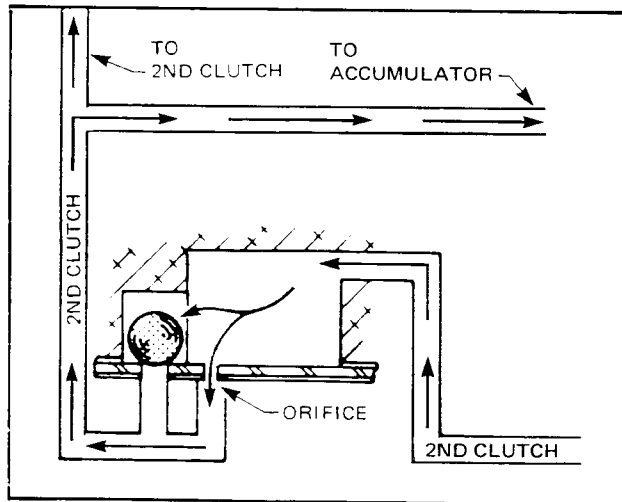

Figure 7C-16

1.15 PRESSURE REGULATOR BOOST VALVE AND SLEEVE

The transmission pressure regulator boost valve and sleeve have been revised on LS code transmissions.

For details of the boost valve and sleeve used on the three transmissions refer to Figs. 7C-17, 7C-18 and the charts below.

VALVE CHART

TRANS. CODE	A	B
LP	15.126 – 15.118 mm	11.765 – 11.758 mm
LR	15.126 – 15.118 mm	11.765 – 11.758 mm
LS	16.502 – 16.494 mm	13.786 – 13.779 mm

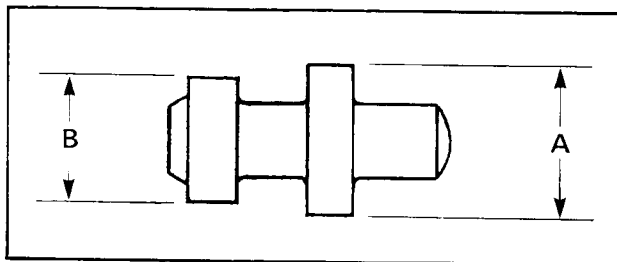

Figure 7C-17

SLEEVE CHART

TRANS. CODE	A	B
LP	15.159 – 15.138 mm	11.796 – 11.778 mm
LR	15.159 – 15.138 mm	11.796 – 11.778 mm
LS	16.535 – 16.515 mm	13.819 – 13.779 mm

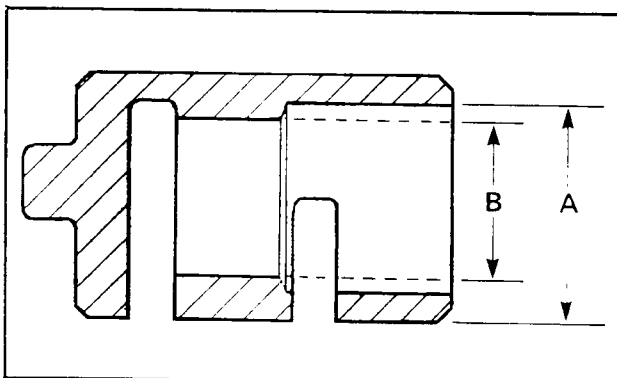

Figure 7C-18

AUTOMATIC TRANSMISSION 7C-7

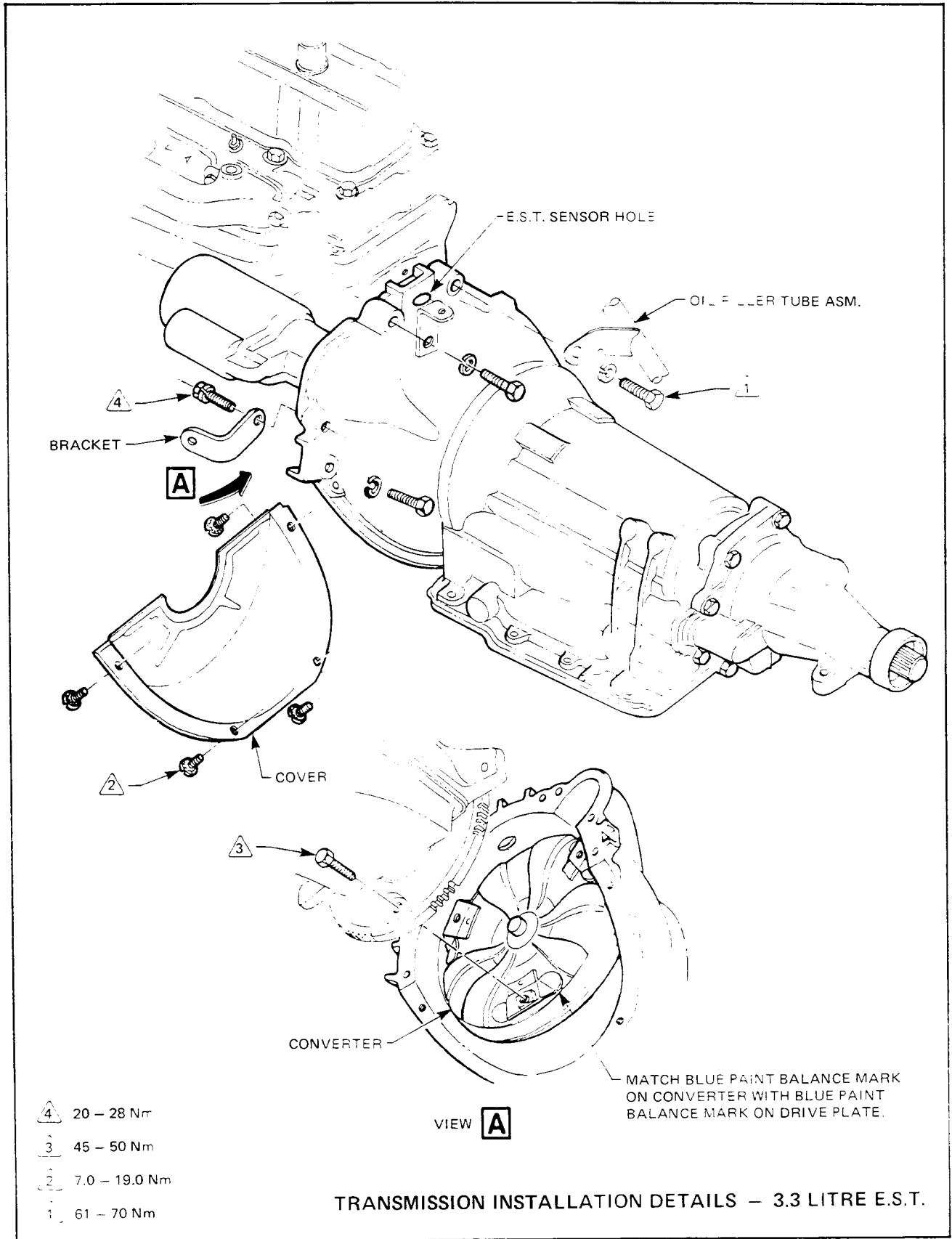

Figure 7C-19

7C-8 AUTOMATIC TRANSMISSION

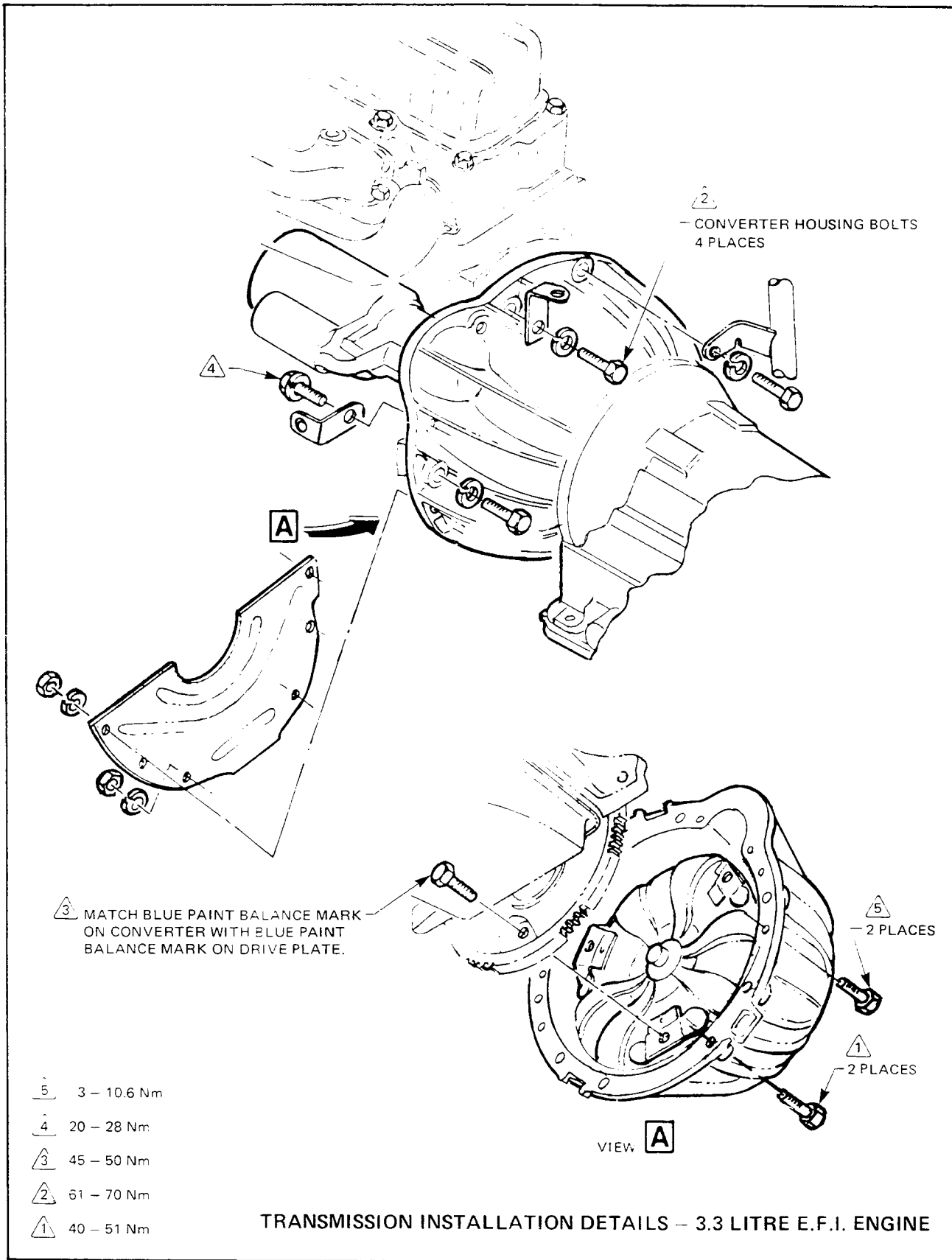

Figure 7C-20

AUTOMATIC TRANSMISSION 7C-9

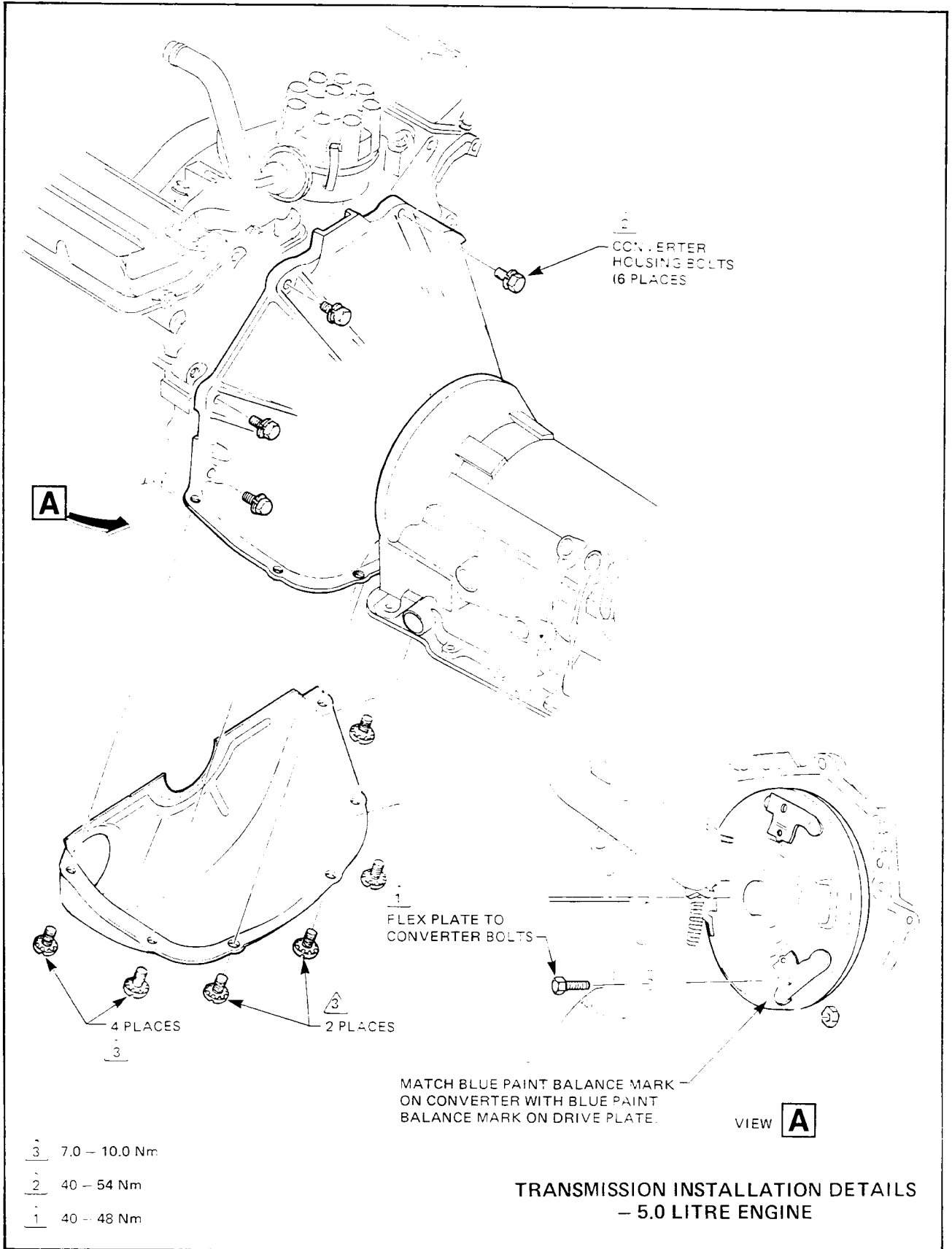
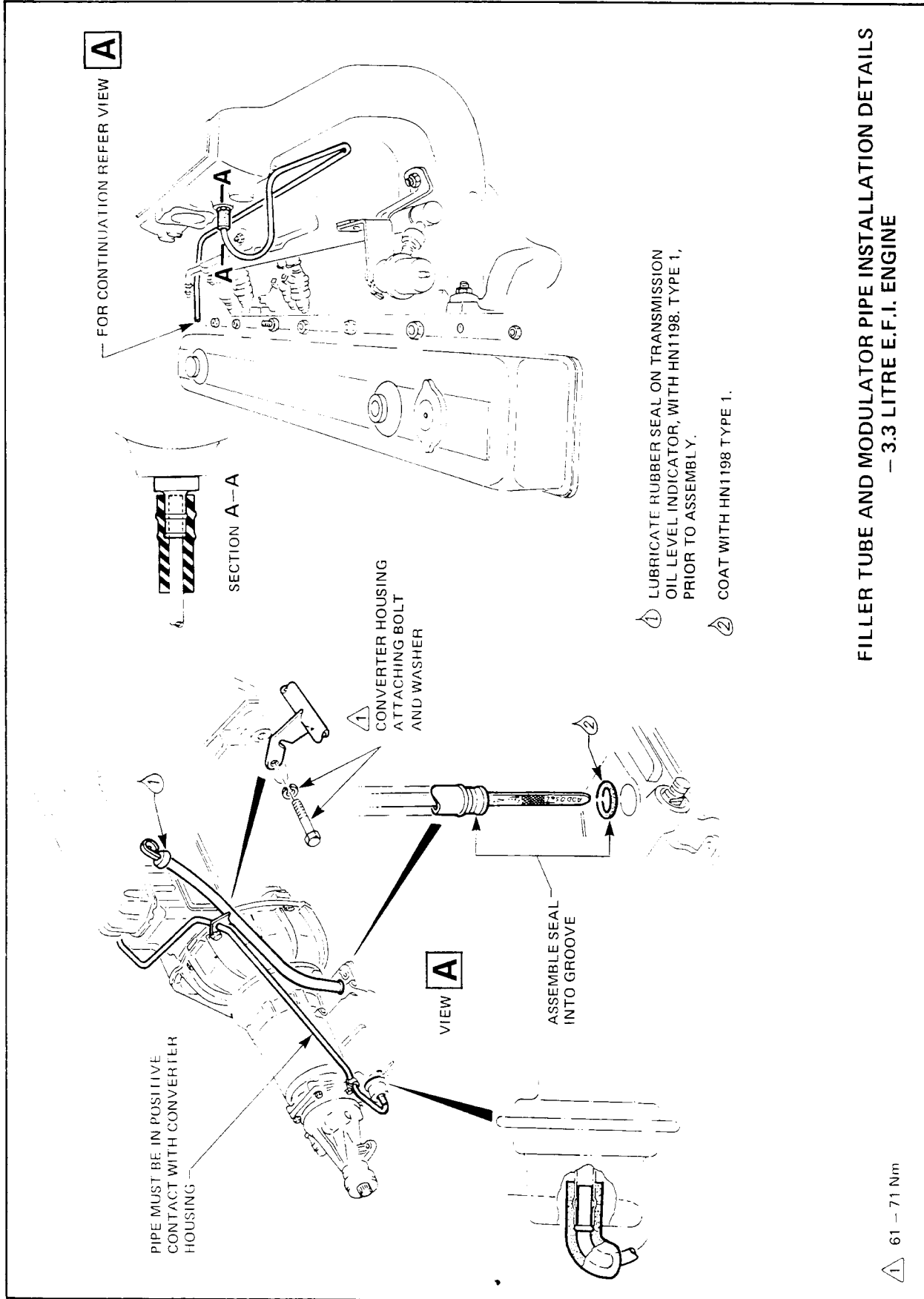

Figure 7C-21

7C-10 AUTOMATIC TRANSMISSION



FILLER TUBE AND MODULATOR PIPE INSTALLATION DETAILS
 — 3.3 LITRE E.F.I. ENGINE

Figure 7C-22

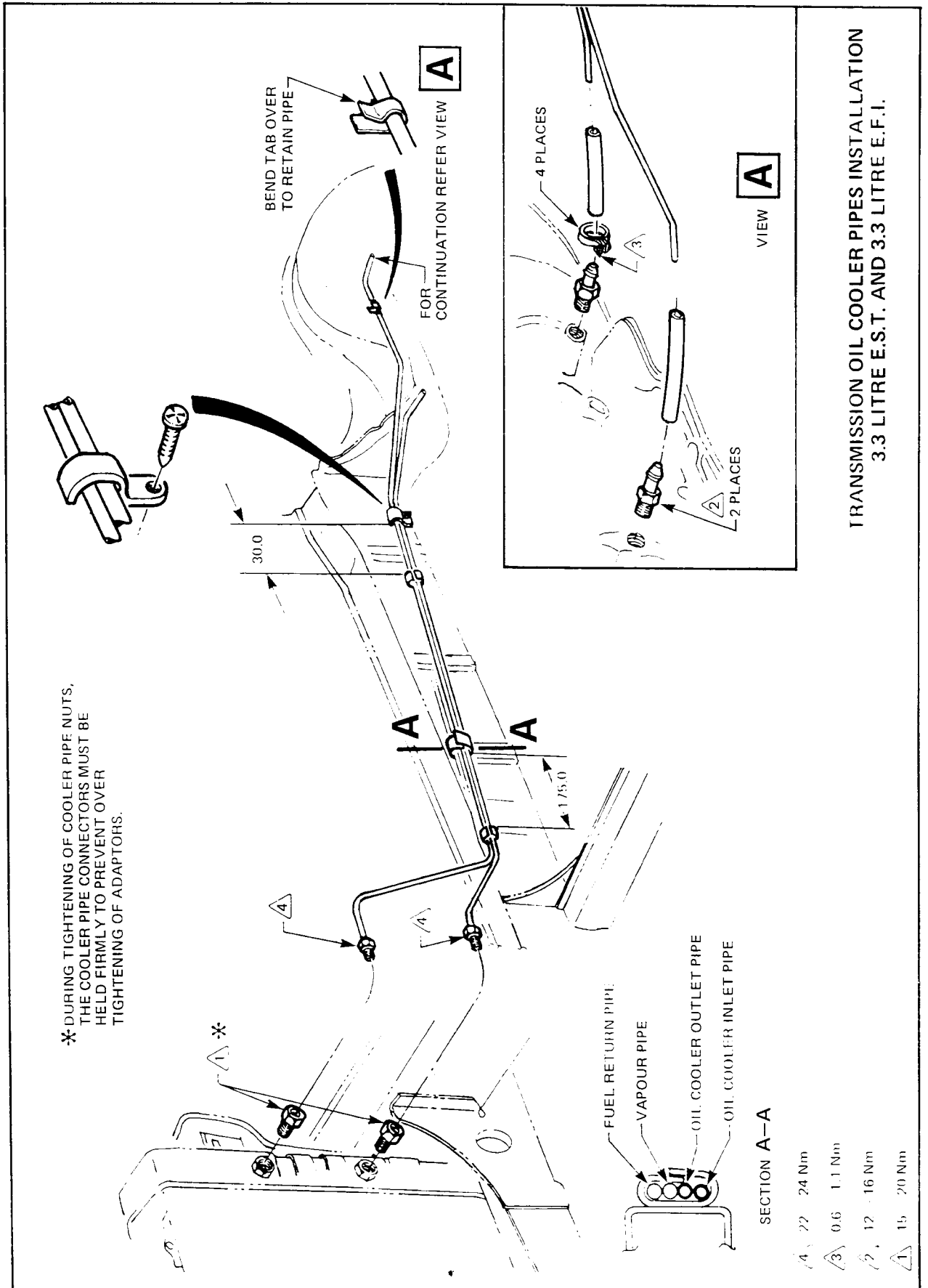

Figure 7C-23

7C-12 AUTOMATIC TRANSMISSION

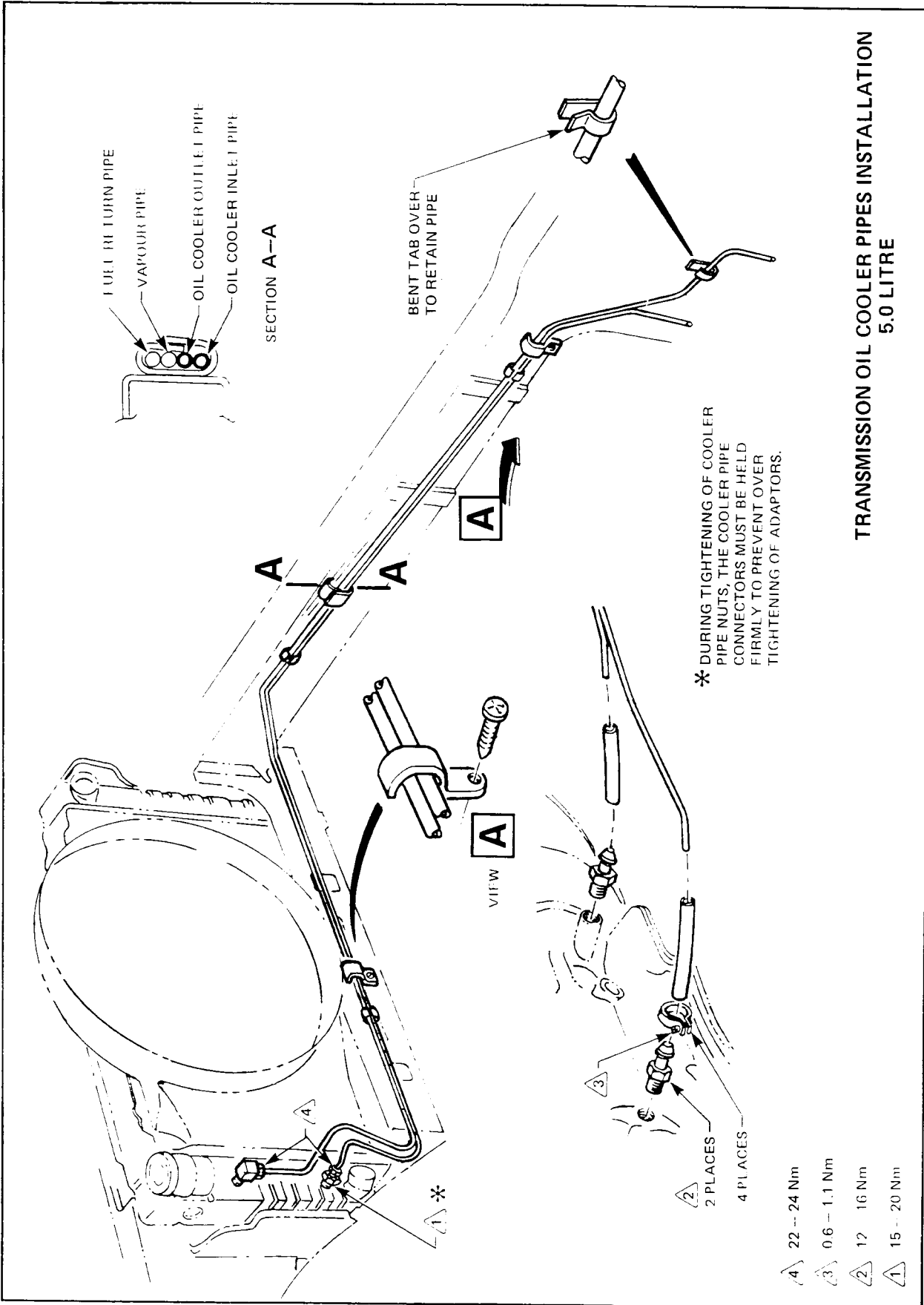

Figure 7C-24

AUTOMATIC TRANSMISSION 7C-13

2. TRANSMISSION SHIFT SPEED CHART

UPSHIFTS km/h – LP (3.3 litre EST)				
	CLOSED THROTTLE		FULL THROTTLE	
	1 – 2	2 – 3	1 – 2	2 – 3
All Tyre Sizes, 3.08 axle	16 – 18	26 – 30	68 – 76	110 – 120

UPSHIFTS km/h – LR (3.3 litre EFI)				
	CLOSED THROTTLE		FULL THROTTLE	
	1 – 2	2 – 3	1 – 2	2 – 3
All Tyre Sizes, 3.08 axle	16 – 18	31 – 35	73 – 81	121 – 131

UPSHIFTS km/h – LS (5.0 litre)				
	CLOSED THROTTLE		FULL THROTTLE	
	1 – 2	2 – 3	1 – 2	2 – 3
All Tyre Sizes, 2.60 axle	18 – 22	33 – 37	74 – 82	126 – 132

DOWNSHIFTS km/h – LP (3.3 litre EST)					
	CLOSED THROTTLE		FULL THROTTLE	PART THROTTLE	
	2 – 1	3 – 2	3 – 2	2 – 1	3 – 2 (Available Up To *)
All Tyre Sizes, 3.08 axle	13 – 15	24 – 28	103 – 113	60 – 65	77 – 83

DOWNSHIFTS km/h – LR (3.3 litre EFI)					
	CLOSED THROTTLE		FULL THROTTLE	PART THROTTLE	
	2 – 1	3 – 2	3 – 2	2 – 1	3 – 2 (Available Up To *)
All Tyre Sizes, 3.08 axle	12 – 14	28 – 32	114 – 124	65 – 73	77 – 83

DOWNSHIFTS km/h – LS (5.0 litre)					
	CLOSED THROTTLE		FULL THROTTLE	PART THROTTLE	
	2 – 1	3 – 2	3 – 2	2 – 1	3 – 2 (Available Up To *)
All Tyre Sizes, 2.60 axle	14 – 16	28 – 32	112 – 122	60 – 68	88 – 94

* WITH DETENT SWITCH DISCONNECTED

7C-14 AUTOMATIC TRANSMISSION

3. TRIMATIC TRANSMISSION SPRING IDENTIFICATION CHARTS

3.1 CODE LP (3.3 LITRE EST ENGINE)

SPRING DESCRIPTION	COLOUR IDENTIFICATION	FREE LENGTH APPROX. mm	TOTAL COILS	O.D. mm NOMINAL	SPRING PART NO.
3 - 2 Control Valve	Yellow	54.7	15.0	13.2	9942033
1 - 2 Accumulator Valve	Pink	16.3	6.0	13.2	92020511
Low Speed Downshift Valve	Dark Blue	35.7	14.0	10.3	2823165
High Speed Downshift Timing Valve	Purple	36.8	13.5	10.3	2816882
Detent Pressure Regulator Valve	Orange	42.8	13.5	12	92004309
* 1 - 2 Shift Valve	Orange	41.0	13.5	10.3	2817224
1 - 2 Control Valve	Orange	32.8	10.3	14.2	92007171
2 - 3 Control Valve	None	36.5	10.3	14.2	9942010
2 - 3 Shift Valve	-	-	-	-	Not Used
Man. Low & Rev. Control Valves	Green & White	38.7	11.5	10.3	5258547
Pressure Regulator Valve	White	70.3	12.3	19.6	5258166
Detent Valve	Green & Red	36.8	13.5	10.3	9929681
Accumulator Piston	-	-	-	-	Not Used
Gov. Secondary	Green & Orange	39.0	11.5	10.3	9944999
Servo Piston Release	Light Green	59.7	5.75	47.0	92020646
Servo Piston Cushion	Red	26.8	4	31.9	5258564

* Fits inside Shift Valve

3.2 CODE LR (3.3 LITRE EFI ENGINE)

SPRING DESCRIPTION	COLOUR IDENTIFICATION	FREE LENGTH APPROX. mm	TOTAL COILS	O.D. mm NOMINAL	SPRING PART NO.
3 - 2 Control Valve	Orange	57.2	15	13.2	9942032
1 - 2 Accumulator Valve	-	-	-	-	Not Used
Low Speed Downshift Valve	Orange	41	13.5	10.3	2817224
High Speed Downshift Timing Valve	Purple	36.8	13.5	10.3	2816882
Detent Pressure Regulator Valve	None	44.2	13.5	12.0	2811015
1 - 2 Control Valve	Orange	32.8	10.3	14.2	92007171
* 1 - 2 Shift Valve	Orange	41	13.5	10.3	2817224
2 - 3 Control Valve	None	36.5	10.3	14.2	9942010
2 - 3 Shift Valve	Yellow	31.5	11	18.3	9928443
Man. Low & Rev. Control Valves	Green & White	38.7	11.5	10.3	5258547
Pressure Regulator Valve	None	64.9	12.3	19.6	2810499
Detent Valve	Green & Red	36.8	13.5	10.3	9929681
Accumulator Piston	-	-	-	-	Not Used
Gov. Secondary	Green & Orange	39.0	11.5	10.3	9944999
Servo Piston Release	Green	65.8	5.75	47.0	92020646
Servo Piston Cushion	Orange	25.9	3.9	31.9	5258568

* Fits inside Shift Valve

AUTOMATIC TRANSMISSION 7C-15

3.3 CODE LS (5.0 LITRE ENGINE)

SPRING DESCRIPTION	COLOUR IDENTIFICATION	FREE LENGTH APPROX. mm	TOTAL COILS	O.D. mm NOMINAL	SPRING PART NO.
3 – 2 Control Valve	Light Green	55.9	15	13.2	9945053
1 – 2 Accumulator Valve	Light Blue	16.9	5.5	13.2	92020512
Low Speed Downshift Valve	Orange	41	13.5	10.3	2817224
High Speed Downshift Timing Valve	Purple	36.8	13.5	10.3	2816832
Detent Pressure Regulator Valve	Pink	45.4	13.5	12.0	5258582
1 – 2 Control Valve	Orange	32.8	10.3	14.2	92007171
* 1 – 2 Shift Valve	Orange	41	13.5	10.3	2817224
2 – 3 Control Valve	None	36.5	10.3	14.2	9942010
2 – 3 Shift Valve	–	–	–	–	Not Used
Man. Low & Rev. Control Valves	Green & White	38.7	11.5	10.3	5258547
Pressure Regulator Valve	None	64.9	12.3	19.6	2810499
Detent Valve	Green & Red	36.8	13.5	10.3	9929681
Accumulator Piston	–	–	–	–	Not Used
Gov. Secondary	Green & Orange	39.0	11.5	10.3	9944999
Servo Piston Release	Green	65.8	5.75	47.0	92020646
Servo Piston Cushion	Blue	27.8	3.9	31.9	9929676

* Fits inside Shift Valve

4. LINE PRESSURE SPECIFICATION CHART

	TRANSMISSION CODES		
	LP 3.3 litre EST	LR 3.3 litre EFI	LS 5.0 litre
	kPa	kPa	kPa
CHECK NO. 1 – Line Pressure in D + S Ranges (Vacuum Modulator Pipe Connected) Vehicle coasting between 55 – 50 km/h	324 – 360	403 – 425	403 – 425
CHECK NO. 2 – Line Pressure in Low Range (Vacuum Modulator Pipe Connected) Vehicle coasting between 40 – 30 km/h	531 – 614	606 – 688	606 – 668
CHECK NO. 3* – Line Pressure in D Range (Vacuum Modulator Pipe Disconnected) 1200 rpm engine speed – foot and parking brake applied	903 – 978	973 – 1047	1199 – 1273
* During Check No. 3 with the vacuum modulator pipe disconnected, the manifold connector must be plugged to prevent an excessive air leak into the manifold.			

7C-16 AUTOMATIC TRANSMISSION

5. SPECIFICATIONS

TRANSMISSION CODE:	LP – 3.3 litre EST	LR – 3.3 litre EFI	LS – 5.0 litre
SELECTOR LEVER:			
Location	Floor	Floor	Floor
Sequence of Shift Positions	"P" (Park), "R" (Reverse), "N" (Neutral), "D" (Drive), "S" (Intermediate), "L" (Low Range)		
TORQUE CONVERTER ASSEMBLY:			
Method of Attachment to Drive Plate	Welded Nut & Bolt		Nut & Bolt
Identification Letter (Printed Yellow on Front Face of Converter)	X	AA	Y
Stall Ratio :1	2.4	2.4	2.0
Diameter (Nominal)	254 mm	254 mm	298 mm
SPEEDO DRIVE GEAR:			
Number of Teeth	9	9	10
Colour	Blue	Blue	Yellow
GEAR RATIOS:			
First	2.31 : 1	2.31 : 1	2.31 : 1
Second	1.46 : 1	1.46 : 1	1.46 : 1
Third	1.00 : 1	1.00 : 1	1.00 : 1
Reverse	1.85 : 1	1.85 : 1	1.85 : 1
TORQUE MULTIPLICATION:			
Maximum Overall Ratio in 1st :1	5.54	5.54	4.62
LUBRICANT:			
Type	"DEXRON II" Automatic Transmission Fluid		
Capacity – Dry (including Converter)	6.1 litres	6.1 litres	8.7 litres
Refill	2.3 litres	2.3 litres	2.3 litres
FLUID LEVEL INDICATOR (DIPSTICK):			
Length (From Top of Cap to End of Indicator)	808 mm	808 mm	680 mm
CLUTCHES:			
Reverse	Multiple Wet Disc		
Drive Plates	Friction Facing on Steel Plate		
Description			
Number	4	4	5
Reaction Plates			
Description	Steel	Steel	Steel
Number	5	5	6
Piston			
Length	35.99–36.09 mm	35.99–36.09 mm	31.39–31.50 mm
Cushion Plate Used	Yes	Yes	Yes
Second	Multiple Wet Disc		
Drive Plates	Friction Facing on Steel Plate		
Description			
Number	5	5	6

AUTOMATIC TRANSMISSION 7C-17

SPECIFICATIONS (CONT'D.)

TRANSMISSION CODE:

LP – 3.3 litre EST	LR – 3.3 litre EFI	LS – 5.0 litre
--------------------	--------------------	----------------

CLUTCHES (Cont'd.)

Driven Plates			
Description	Steel	Steel	Steel
* Number	6	6	7
Cushion Plate Used	Yes	Yes	Yes
* NOTE: Some Transmissions have one additional Steel Plate and one or more Spacer Plates.			
Spacer			
Length	35.63–35.74 mm	35.63–35.74 mm	31.04–31.14 mm
Second Clutch Spacers can also be identified by the last digit of the Part Number on the Spacer.			
Spacer Part Number application	2820681	2820681	92019879
Clutch Pack End Play38/.76 mm	.38/.76 mm	.38/.76 mm
Third			
Type	Multiple Wet Disc		
Drive Plates			
Description	Friction Facing on Steel Plate		
Number	4	4	5
Driven Plates			
Description	Steel	Steel	Steel
Number	5	5	6
Piston			
Length	17.17–17.27 mm	17.17–17.27 mm	13.51–13.61 mm
Cushion Plate Used	Yes	Yes	Yes
One Way Clutch			
Type	Sprag	Sprag	Sprag
Function	Connects Input to Gear Set in First Gear Drive, Overruns or by-passed in other conditions.		

SECTION 8A

FUEL TANK

INDEX

Ref.	Subject	Page	Ref.	Subject	Page
1.	GENERAL INFORMATION	8A-1	1.3	FUEL TANK	8A-3
1.1	SWIRL POT	8A-2	2.	TORQUE WRENCH SPECIFICATIONS.....	8A-12
1.2	FUEL GAUGE TANK UNIT	8A-2			

1. GENERAL INFORMATION

The fuel tank for VK Series models with 3.3 litre EST engine carries over from VH, except for the deletion of the fuel filler limiter pot from inside the fuel tank and revision to the fuel filler cap pressure relief valve. Pressure is now 12 to 16 kPa. Revision has also been made to the fuel venting system due to the deletion of the fuel filler limiter pot.

Revisions introduced for 3.3 litre EFI equipped vehicles, include the same modifications to the venting system, fuel filler cap and the deletion of the fuel filler limiter pot as for 3.3 EST engines. Additions include a swirl pot and a new fuel gauge tank unit (Fig. 8A-1).

Also incorporated in the fuel tank for EFI equipped vehicles is a fuel return line, which delivers fuel from the EFI fuel pressure regulator, back to the swirl pot.

VK Series models with 5.0 litre engines, incorporate a hot fuel handling package, refer to Section 6C 'Engine Fuel 5.0 litre Engines' of this Supplement. The changes made to the 3.3 litre EST fuel tank carry over for use with the 5.0 litre engines.

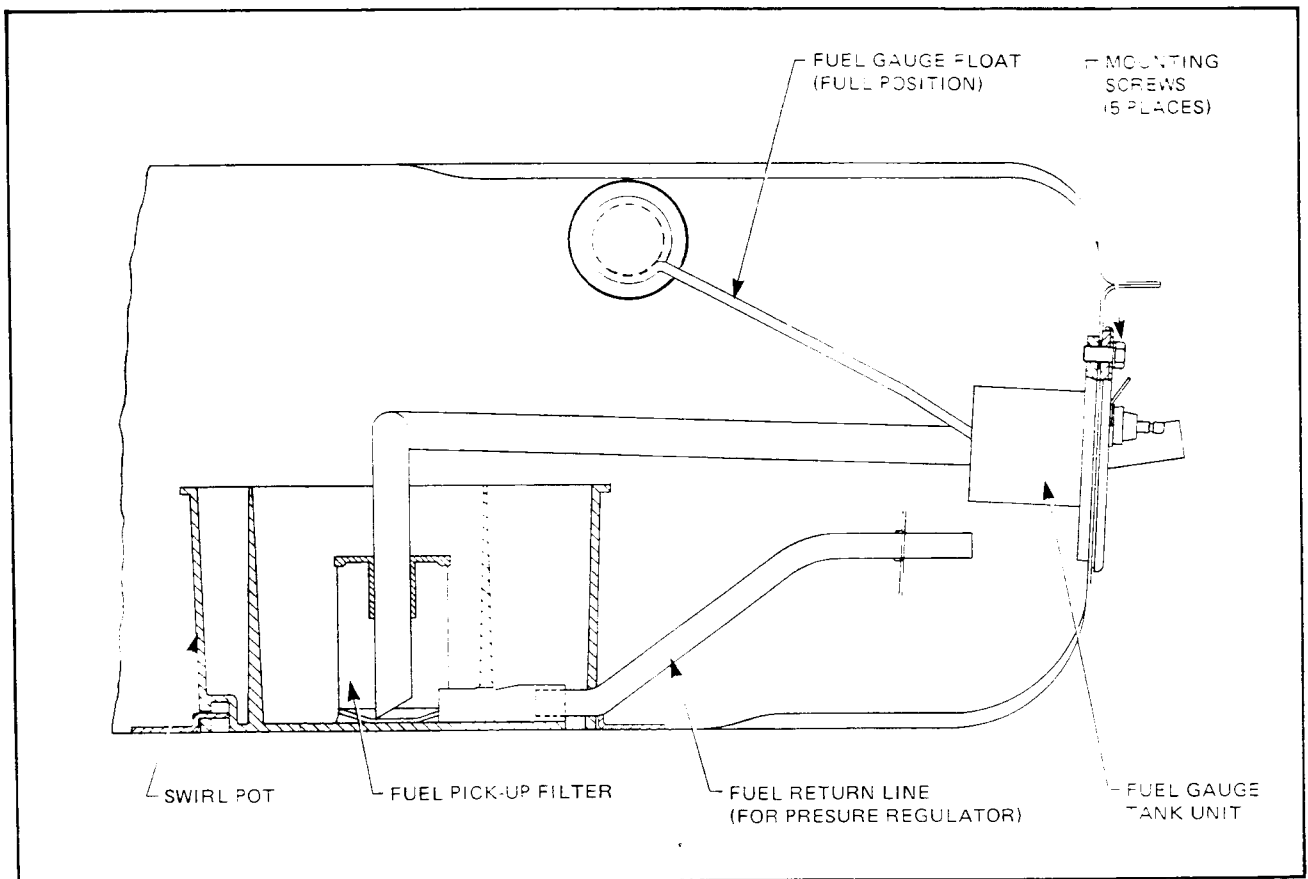

Figure 8A-1

8A-2 FUEL TANK

1.1 SWIRL POT

The plastic swirl pot, located inside the fuel tank on 3.3 litre EFI models, is mounted on the bottom of the tank (Fig. 8A-2). It provides a reservoir of fuel to prevent the fuel pick up becoming uncovered during cornering or when the fuel level in the tank is low.

For practical purposes, the swirl pot is part of the tank and no service work is possible on it.

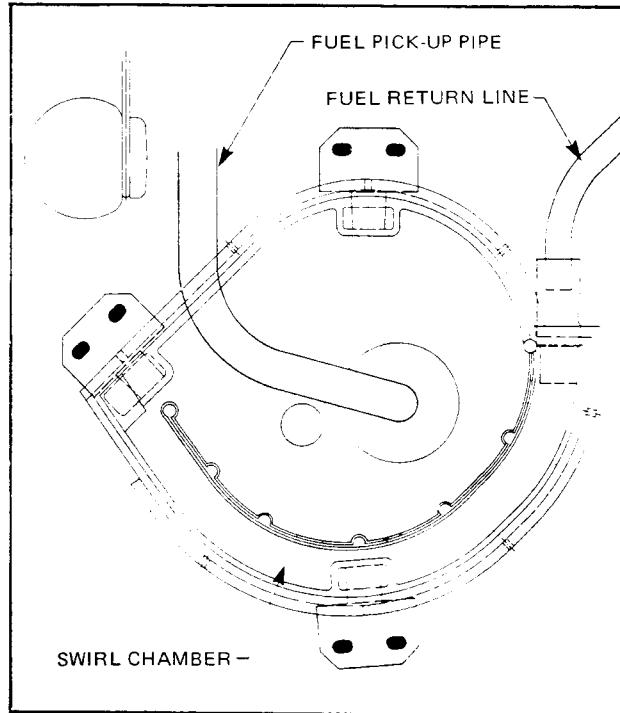

Figure 8A-2

The fuel return line is connected to a venturi at the base of the swirl pot. This high velocity jet of fuel picks up extra fuel and delivers it to the pot through a tangential passage. This keeps the pot full of fuel irrespective of the level in the tank, and the swirling action separates air and vapour from the fuel (refer Fig. 8A-3).

The continuous supply of fuel to the swirl pot ensures that the fuel pick up does not draw any air into the fuel system.

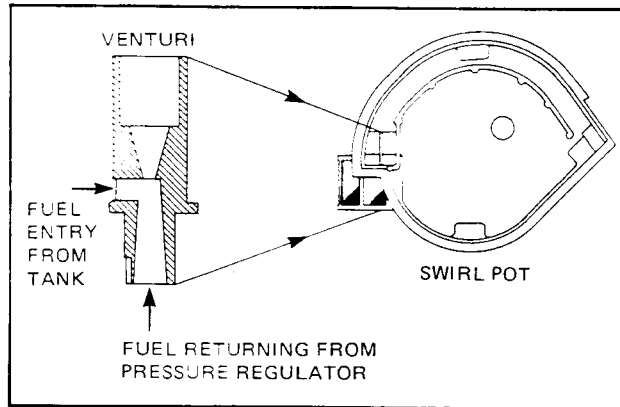

Figure 8A-3

1.2 FUEL GAUGE TANK UNIT

The fuel gauge tank unit (Fig. 8A-4) for the EFI system is of a new design and is not interchangeable with previous Commodore tank units. The fuel pick up filter is immersed in fuel inside the swirl pot. The gauge unit is mounted to the tank by 5 screws and sealed against leakage by a cork gasket between the tank and the gauge unit. Sealant Part No. M39040 is applied to the threads of the screws and mating surface of cork seal to fuel tank.

For removal, testing and reinstallation instructions, refer to service operation 2.6, Section 12 C in this Supplement.

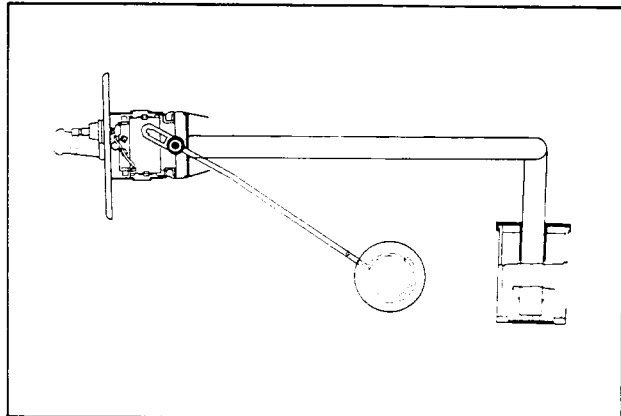

Figure 8A-4

1.3 FUEL TANK

Fuel tank removal and installation instructions remain the same as on previous Commodore models.

The only difference is with EFI models, on removal, the fuel return line must be disconnected and reconnected on installation (refer Fig. 8A-5).

Extreme caution must be exercised when disconnecting either the fuel return hose or the fuel feed hose to the fuel pump, as a great deal of fuel will spill from the hoses.

Before starting vehicle, carry out fuel system leak test as per service operation 3.2, Section 6C, Electronic Fuel Injection, of this Supplement.

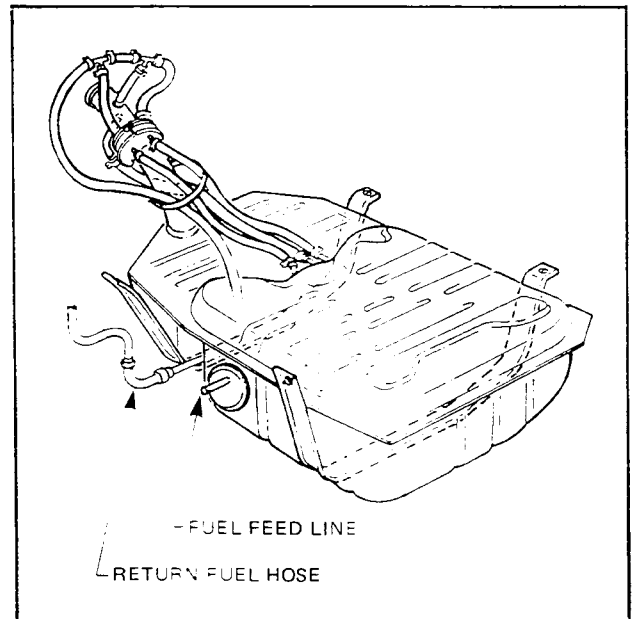

Figure 8A-5

8A-4 FUEL TANK

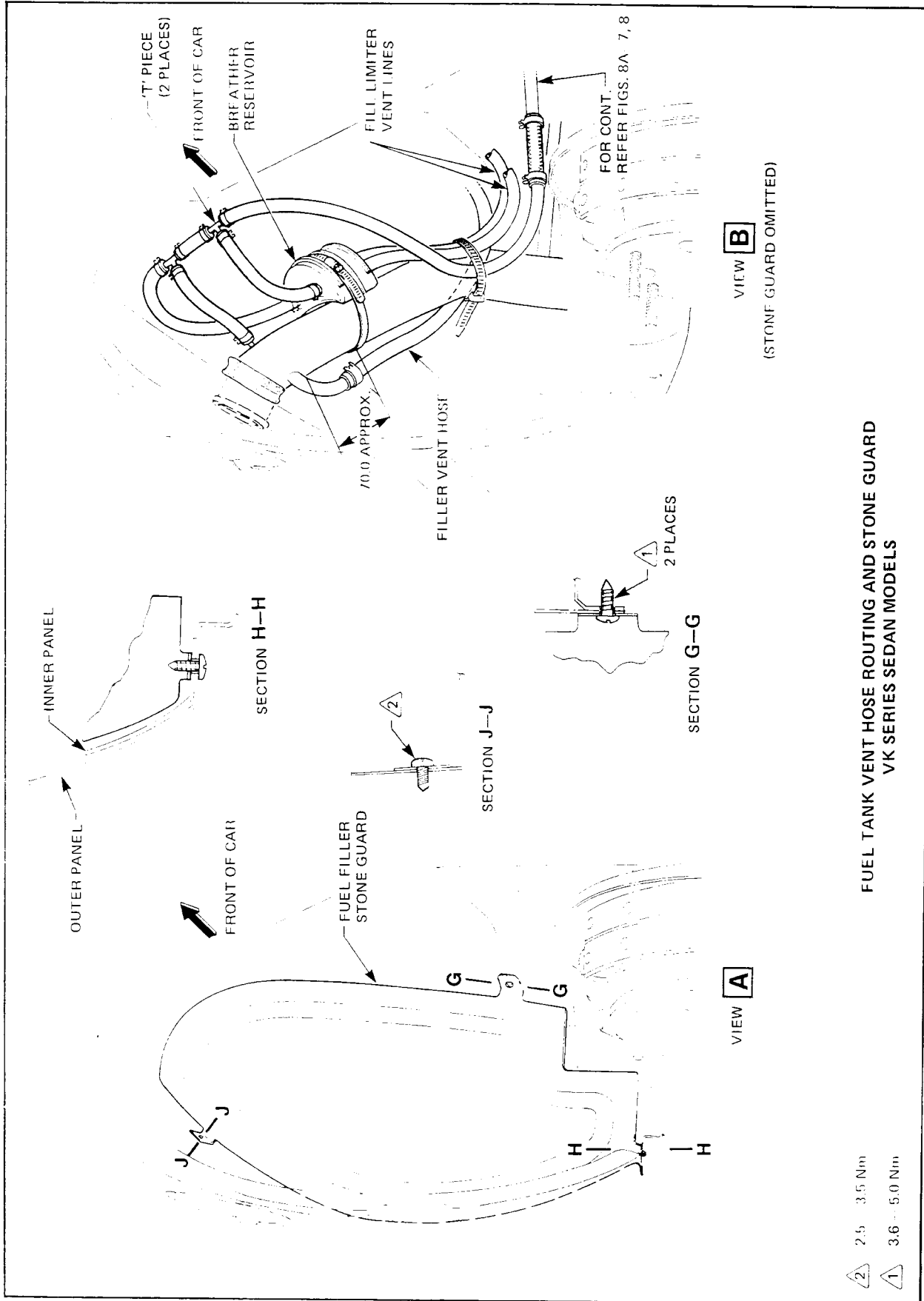

Figure 8A-6

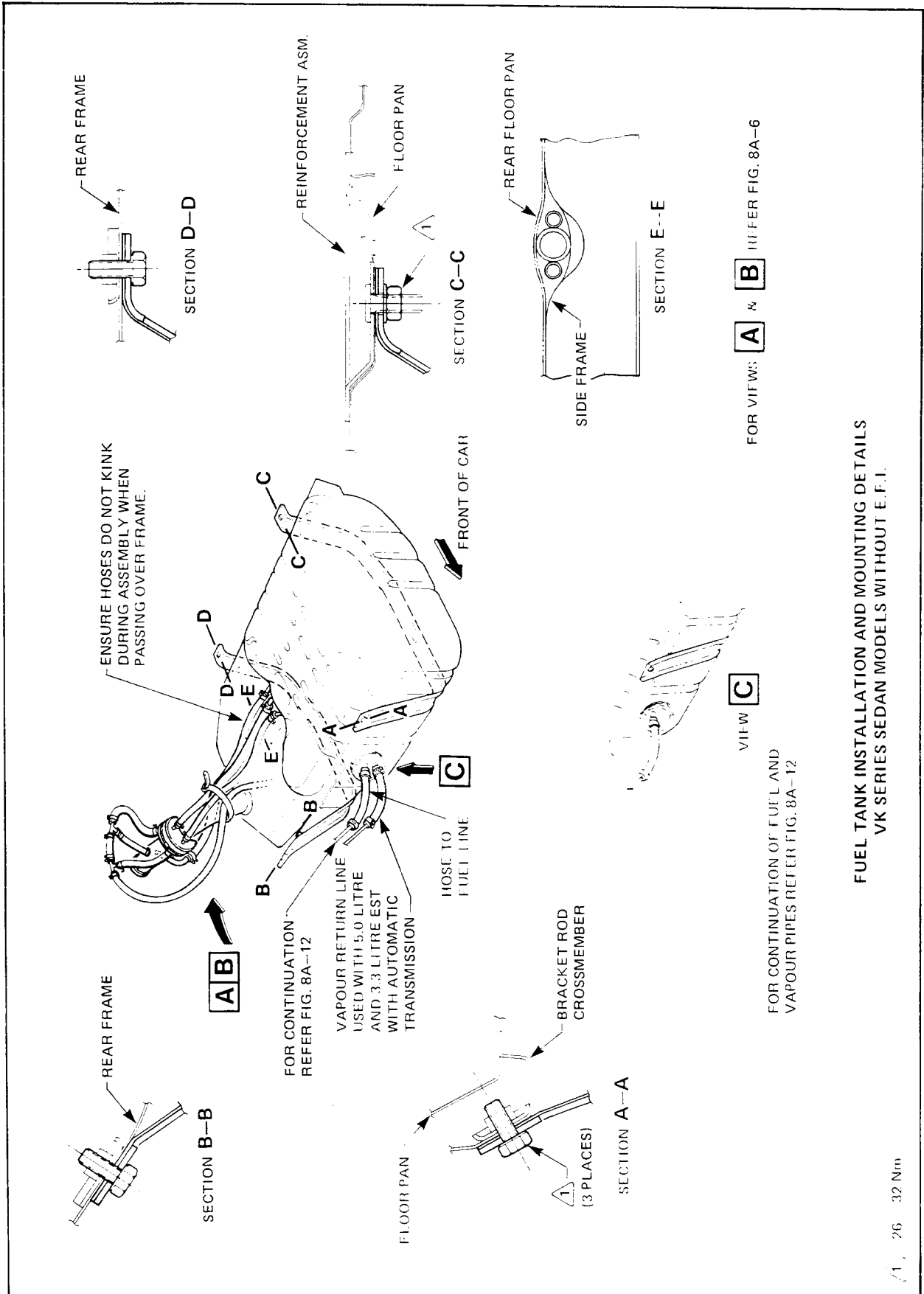

Figure 8A-7

FUEL TANK INSTALLATION AND MOUNTING DETAILS
VK SERIES SEDAN MODELS WITHOUT E.F.I.

8A-6 FUEL TANK

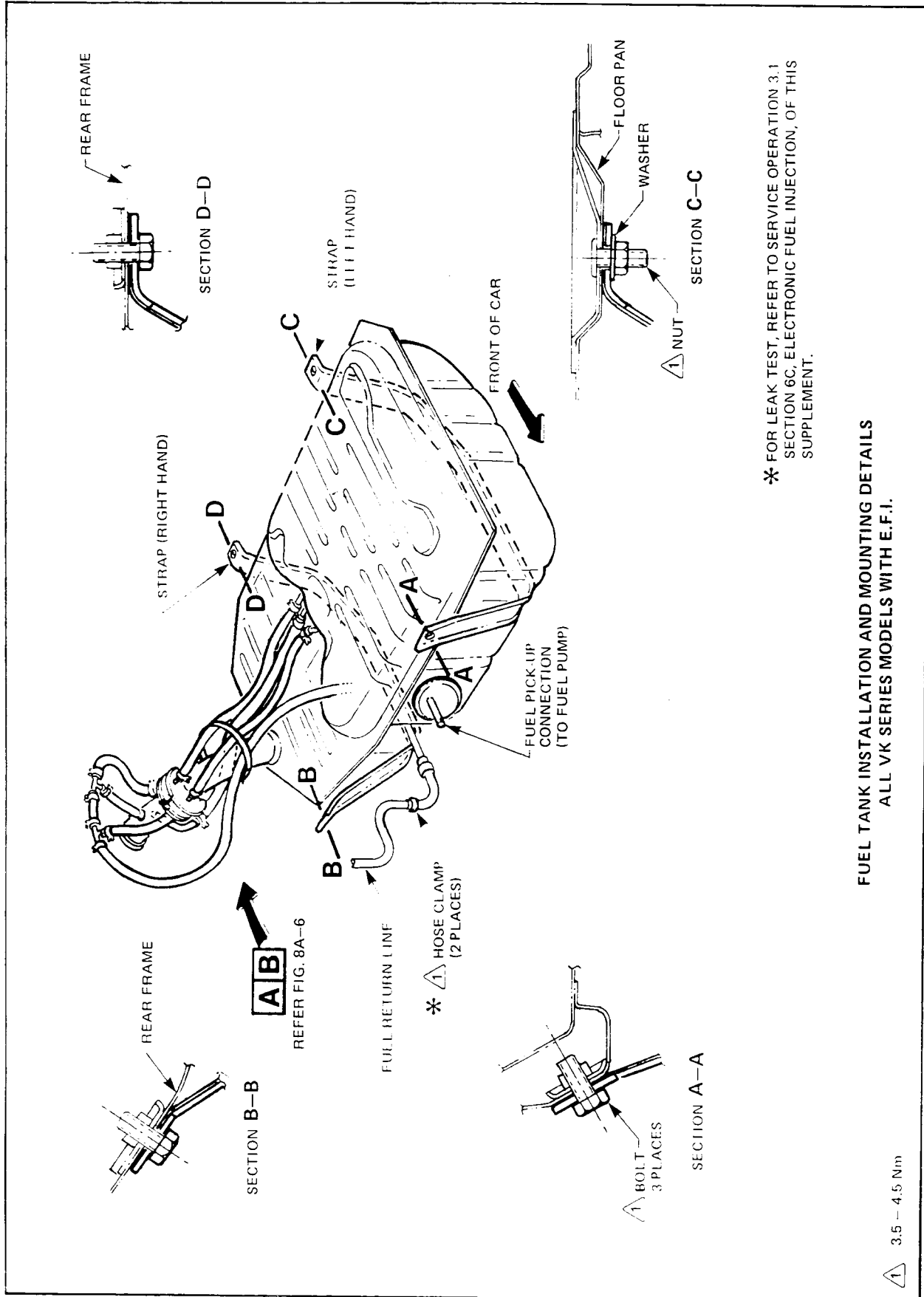
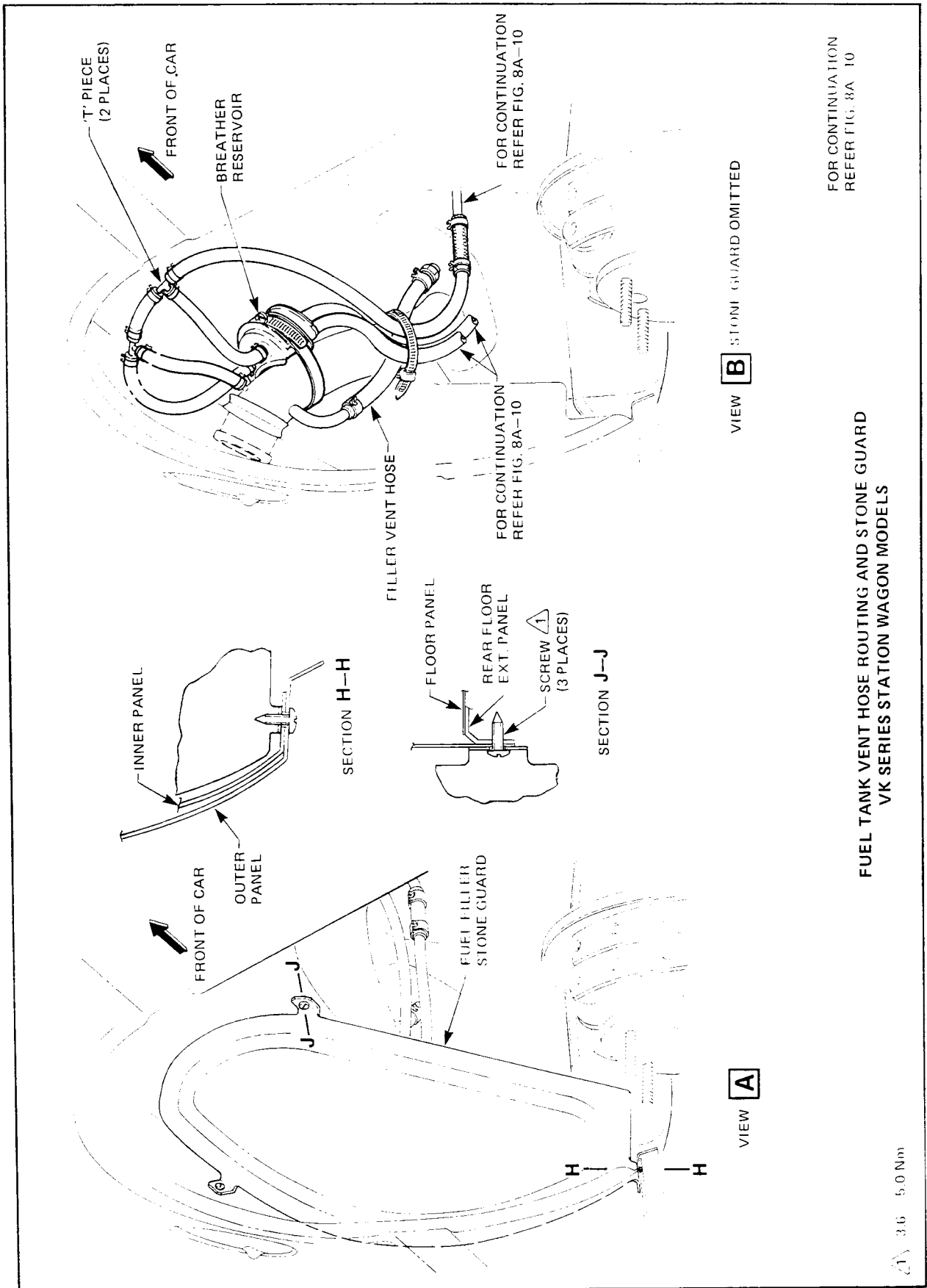

Figure 8A-8

FUEL TANK INSTALLATION AND MOUNTING DETAILS
ALL VK SERIES MODELS WITH E.F.I.



FUEL TANK VENT HOSE ROUTING AND STONE GUARD
VK SERIES STATION WAGON MODELS

Figure 8A-9

8A-8 FUEL TANK

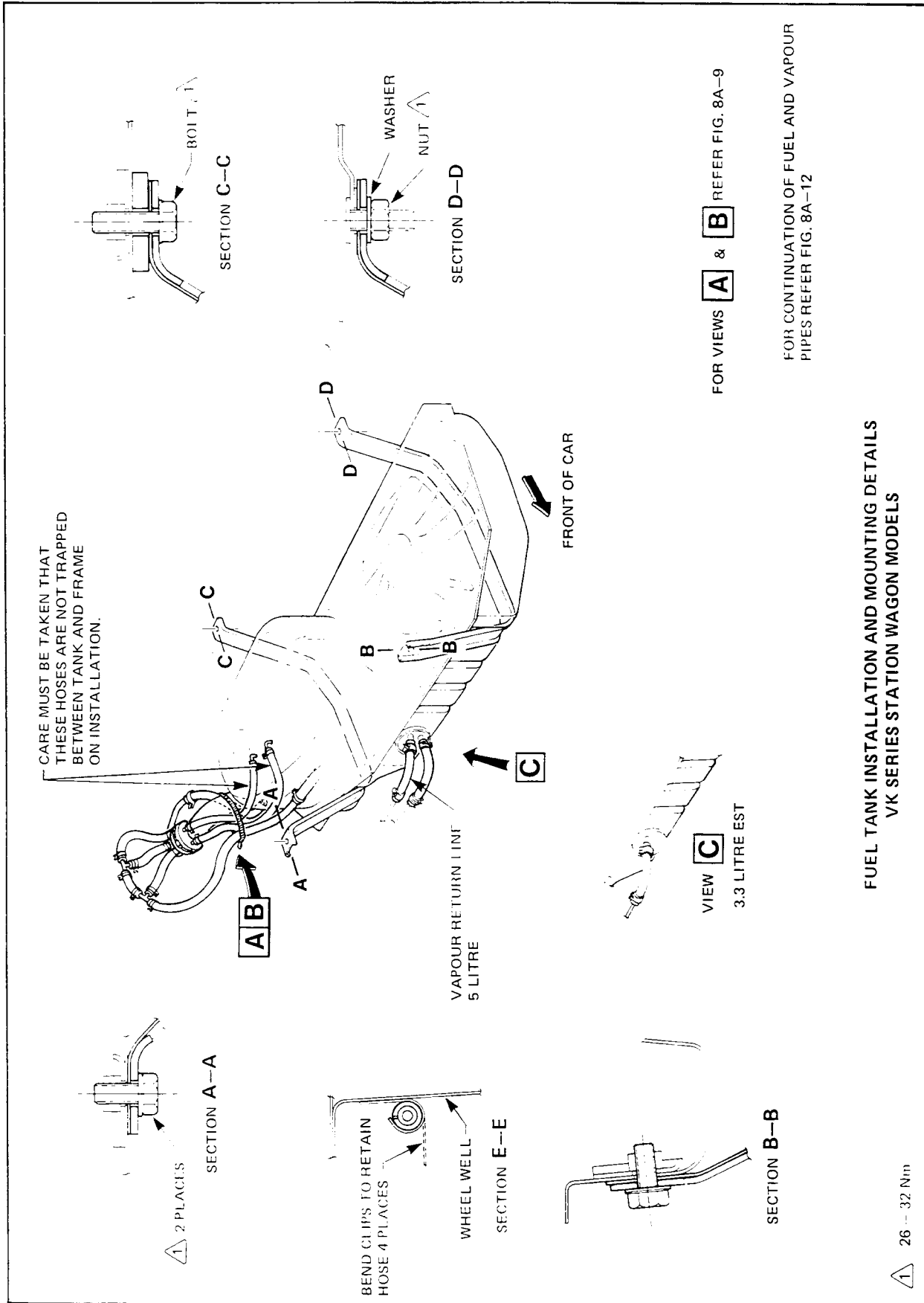
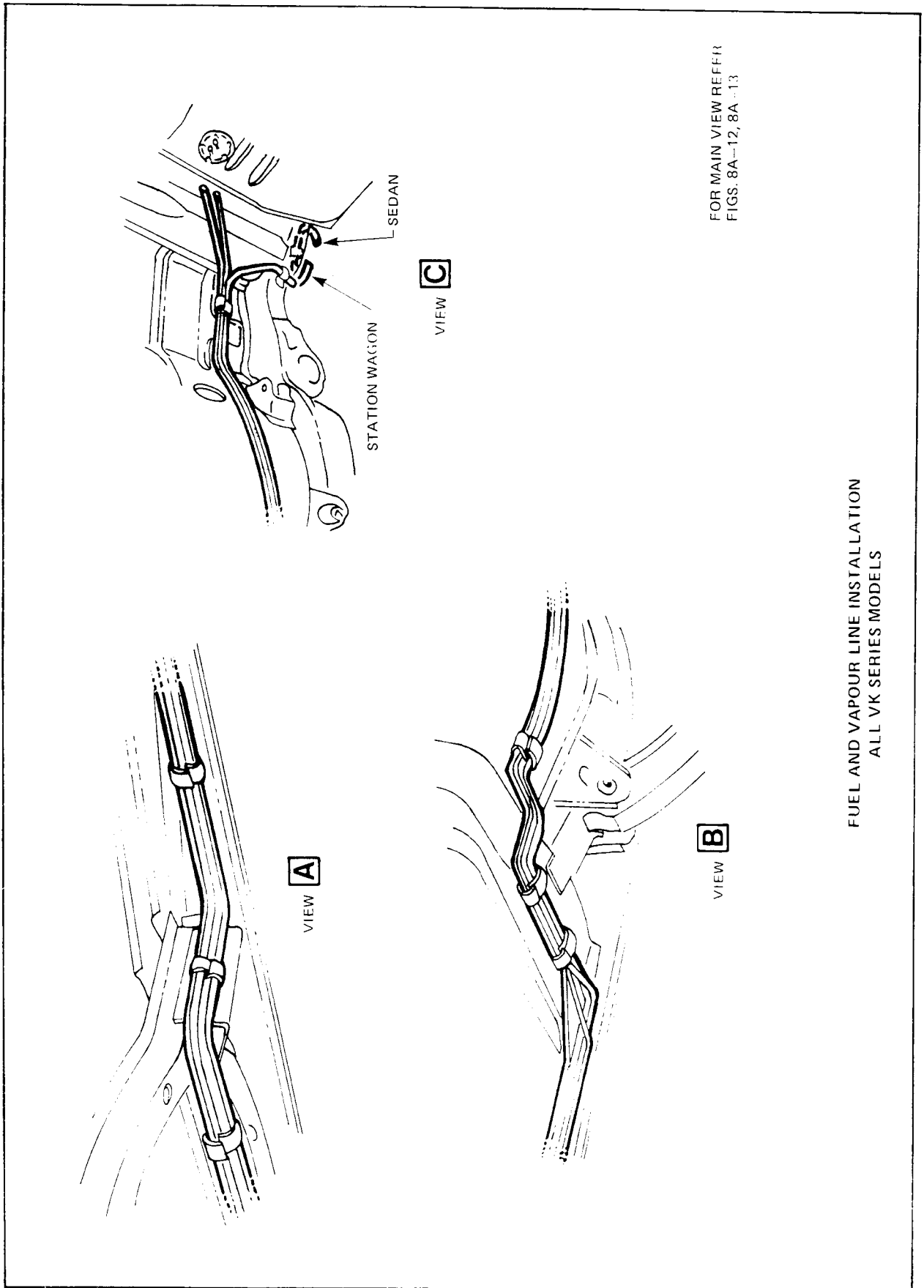

Figure 8A-10



FOR MAIN VIEW REFER
FIGS. 8A-12, 8A-13

FUEL AND VAPOUR LINE INSTALLATION
ALL VK SERIES MODELS

Figure 8A-11

8A-10 FUEL TANK

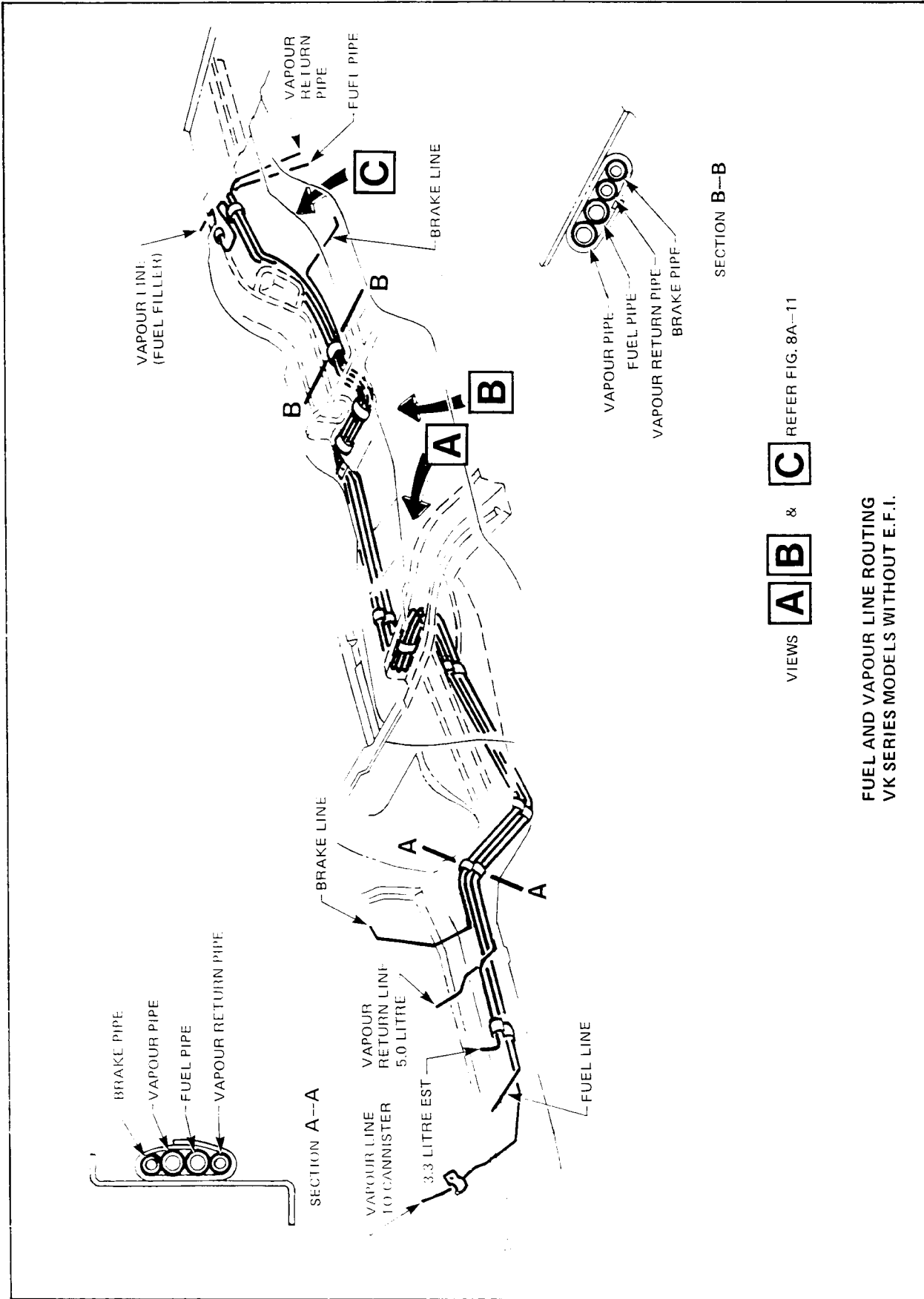
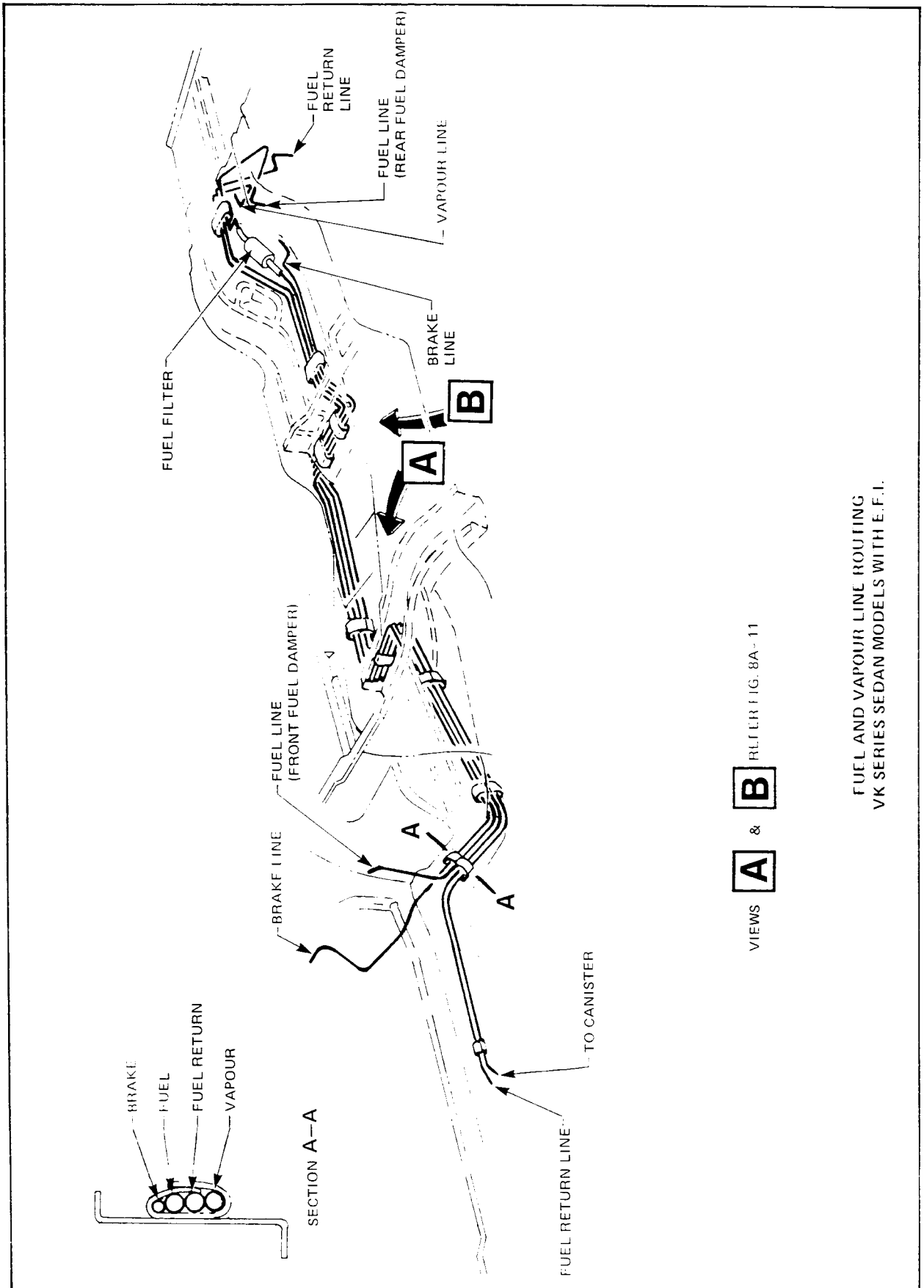

Figure 8A-12



FUEL AND VAPOUR LINE ROUTING
VK SERIES SEDAN MODELS WITH E.F.I.

Figure 8A-13

SECTION 8B

EXHAUST SYSTEM

INDEX

Ref.	Subject	Page	Ref.	Subject	Page
1.	GENERAL DESCRIPTION	8B-1	3.	SPECIFICATIONS	8B-11
2.	SERVICE OPERATIONS	8B-1	4.	TORQUE WRENCH SPECIFICATIONS	8B-12
2.1	EXHAUST EXTRACTOR	8B-1			
	Remove	8B-1			
	Reinstall	8B-2			

1. GENERAL DESCRIPTION

All 3.3 litre VK Series models equipped with Electronic Spark Timing (EST) have a single exhaust system which carries over from VH L6 models.

All 3.3 litre VK Series models equipped with Electronic Fuel Injection (EFI) have the single type exhaust system,

but in place of the standard exhaust manifold, a set of stainless steel exhaust extractors is fitted.

Five litre VK Series models have fitted a dual type exhaust system, which is carried over from VH 5.0 litre models.

2. SERVICE OPERATIONS

When installing the exhaust system, care must be taken to install each part or assembly in correct relation to one another. Incorrect assembly of exhaust system components can frequently be the cause of rattles or 'booms' due to incorrect alignment or clearance from the body or suspension parts.

When installing the exhaust system, ensure that the correct assembly, installation, tightening sequence and clearance for the system involved is observed.

2.1 EXHAUST EXTRACTOR

REMOVE

1. Disconnect battery earth lead.
2. Remove air flow duct and inlet manifold as per service operations 3.9 and 3.11 Section 6C (Electronic Fuel Injection) of this Supplement.
3. Remove generator brace bolt (Fig. 8B-1), disengage fan belt from generator pulley. Loosen generator to support bracket bolt and nut (Fig. 8B-1) and swing generator down away from the engine block.
4. Raise front of vehicle and place on stands.

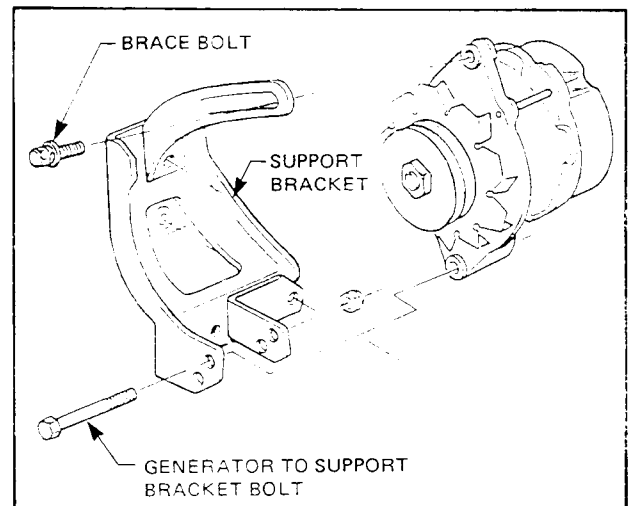

Figure 8B-1

8B-2 EXHAUST SYSTEM

5. Loosen exhaust clamp around exhaust extractors (Fig. 8B-2). Tie up exhaust pipe with wire, so that the pipe is supported when the extractors are removed.
6. Lower front of vehicle.
7. Remove extractor end flange mounting bolts from cylinder head. Disconnect extractors from the exhaust pipe and lift out extractors from engine compartment.

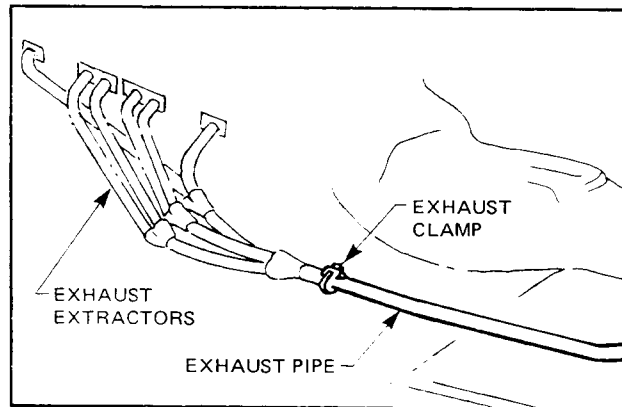
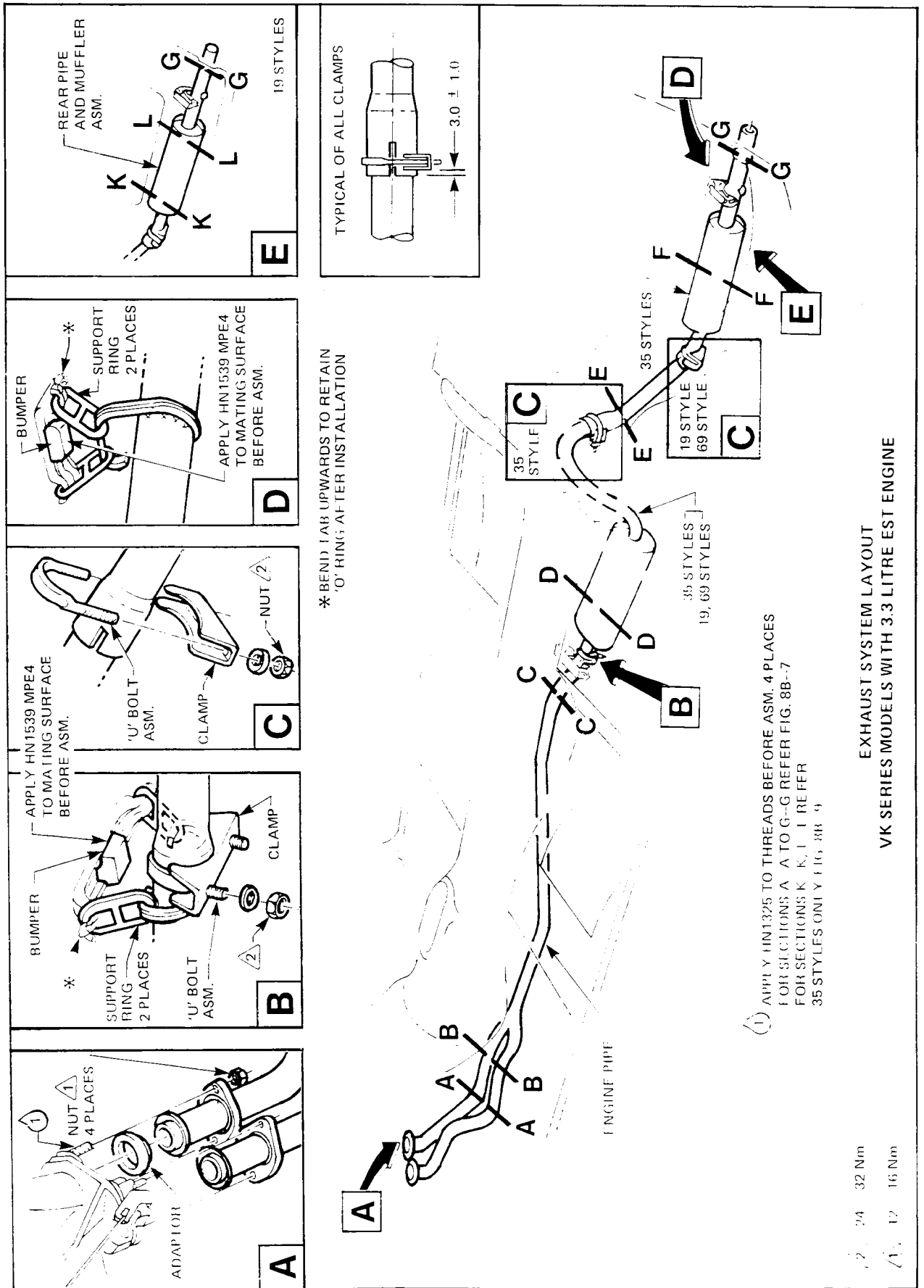

Figure 8B-2

REINSTALL

1. Clean mating surfaces of extractors, inlet manifold and cylinder head.
2. Insert a new manifold gasket in place on the cylinder head.
3. Position extractors, engaging the exhaust pipe and positioning onto cylinder head.
4. Reinstall inlet manifold and air flow duct as per service operations 3.9 and 3.11, Section 6C (Electronic Fuel Injection) of this Supplement.
5. Tighten extractor mounting bolts to torque specified at end of this Section.
6. Refit fan belt and generator brace bolt, readjust fan belt and tighten generator to support bracket bolt and nut.
7. Raise front of vehicle and place on stands.
8. Remove supporting wire. Tighten exhaust clamps and check exhaust system clearance.
9. Connect battery earth lead. Check for fuel leaks as per service operation 3.2, Section 6C (Electronic Fuel Injection) of this Supplement.
10. Start engine and check for exhaust leaks.
11. Lower front of vehicle.

EXHAUST SYSTEM 8B-3



EXHAUST SYSTEM LAYOUT
VK SERIES MODELS WITH 3.3 LITRE EST ENGINE

Figure 8B-3

8B-4 EXHAUST SYSTEM

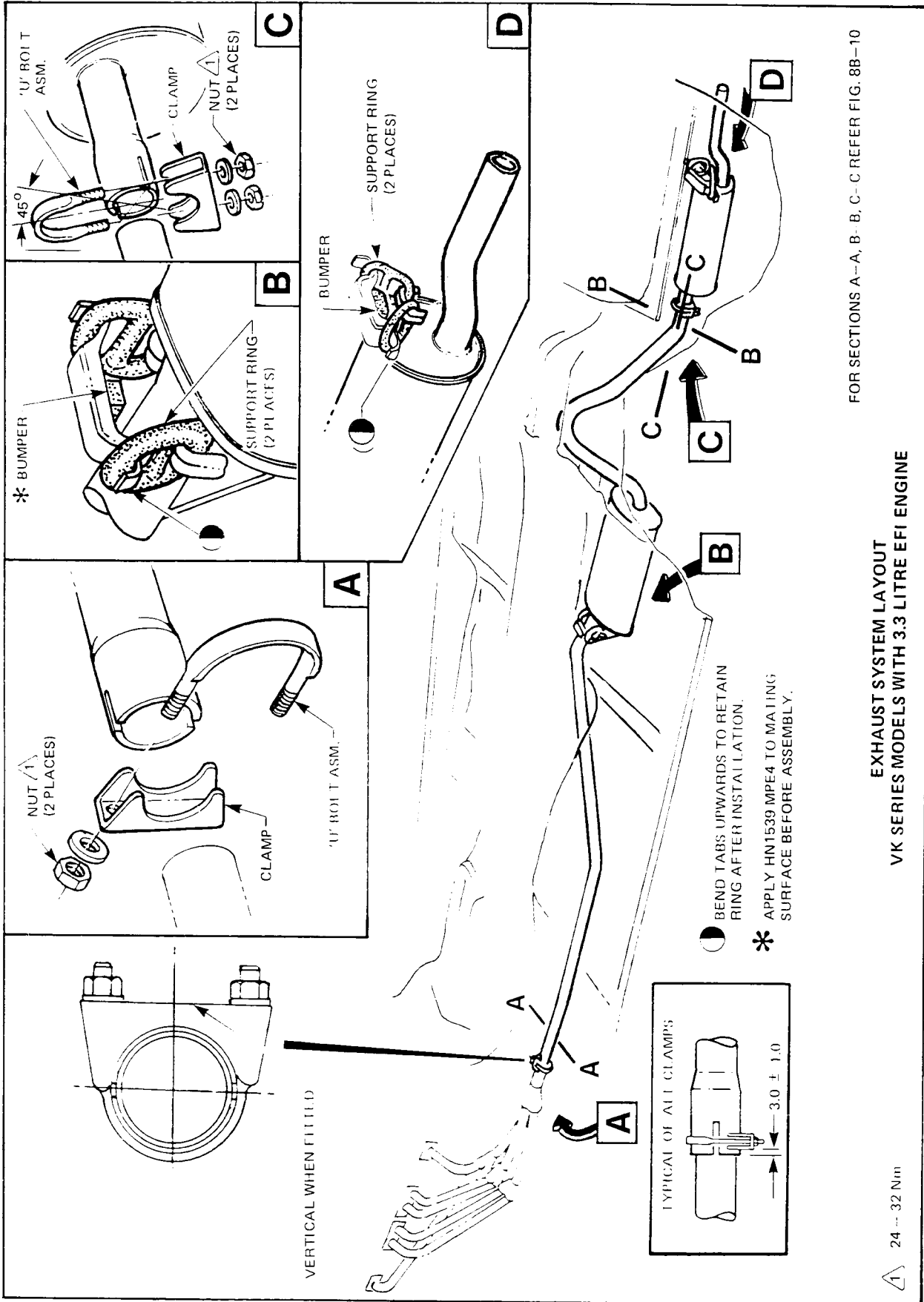

EXHAUST SYSTEM 8B-5

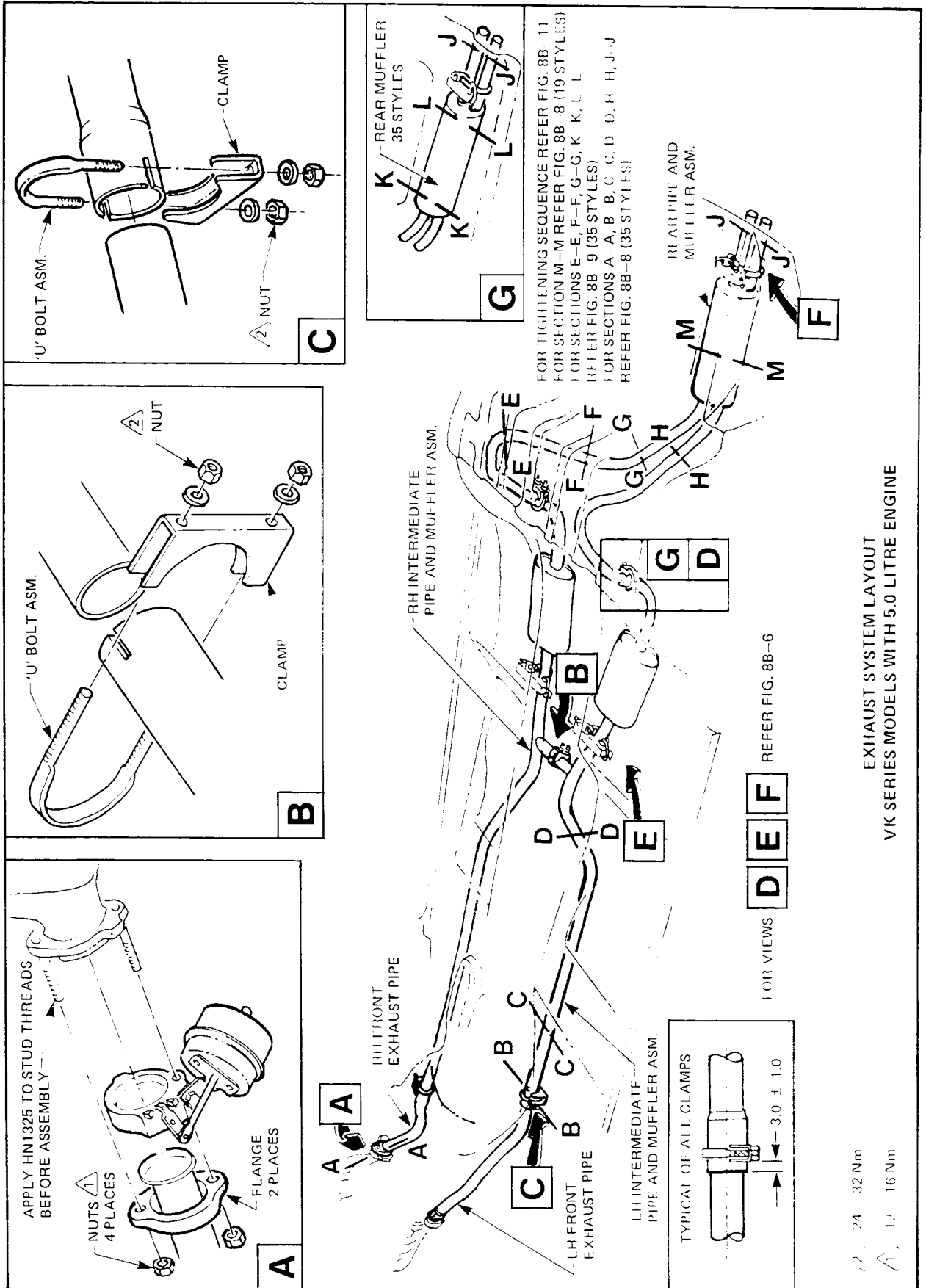

EXHAUST SYSTEM LAYOUT
 VK SERIES MODELS WITH 5.0 LITRE ENGINE

Figure 8B-5

8B-6 EXHAUST SYSTEM

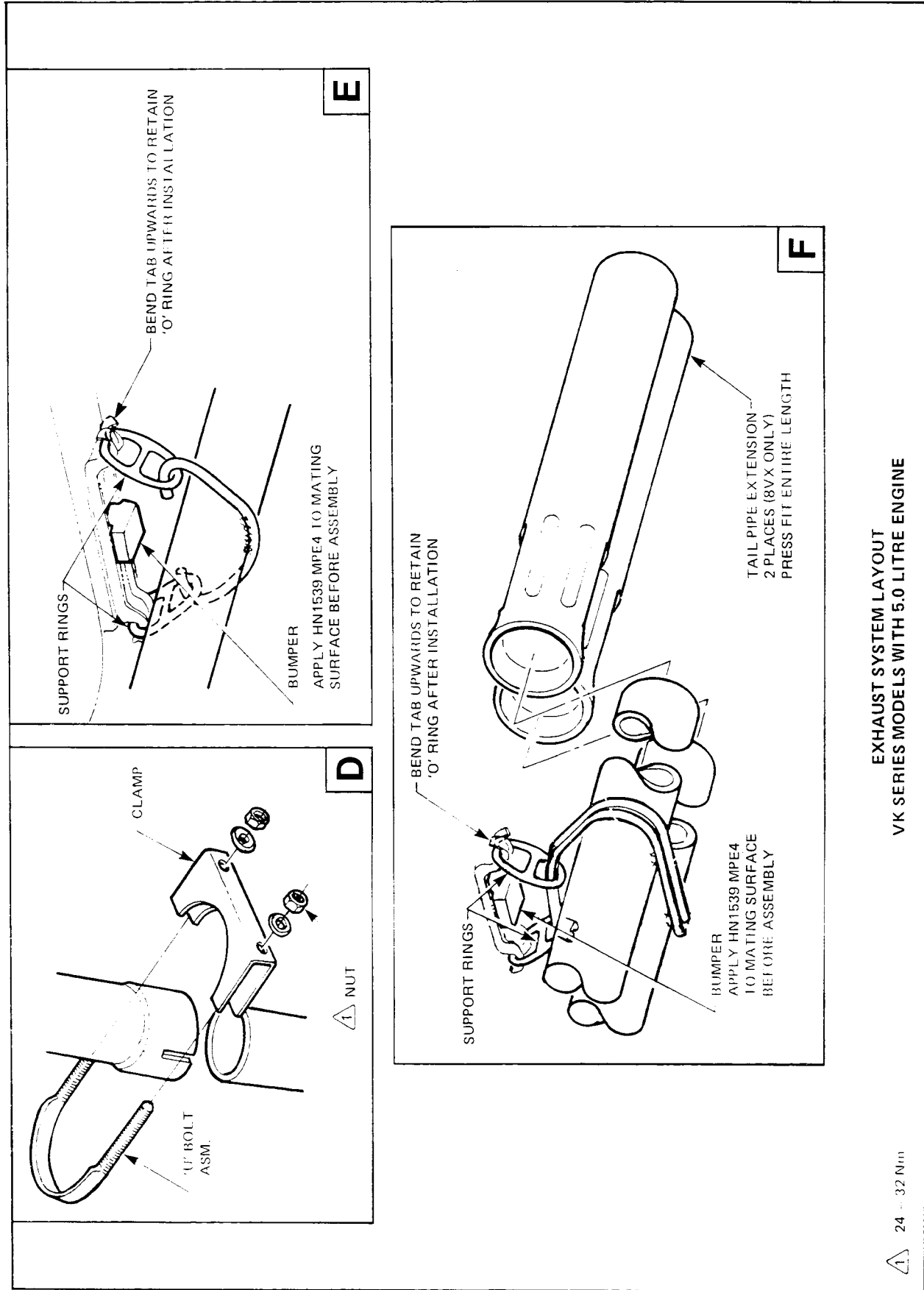

EXHAUST SYSTEM LAYOUT
VK SERIES MODELS WITH 5.0 LITRE ENGINE

Figure 8B-6

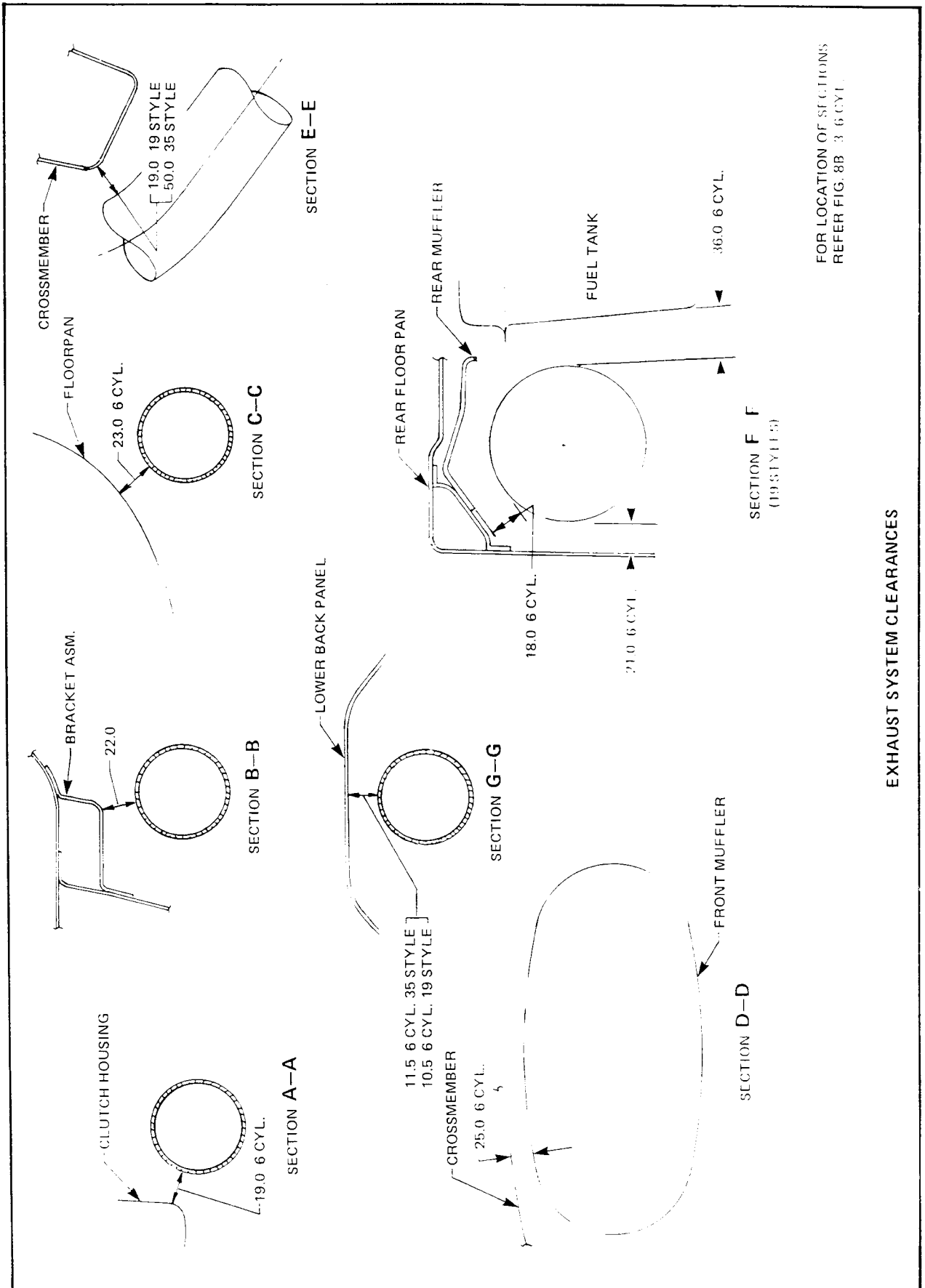

EXHAUST SYSTEM CLEARANCES

Figure 8B-7

8B-8 EXHAUST SYSTEM

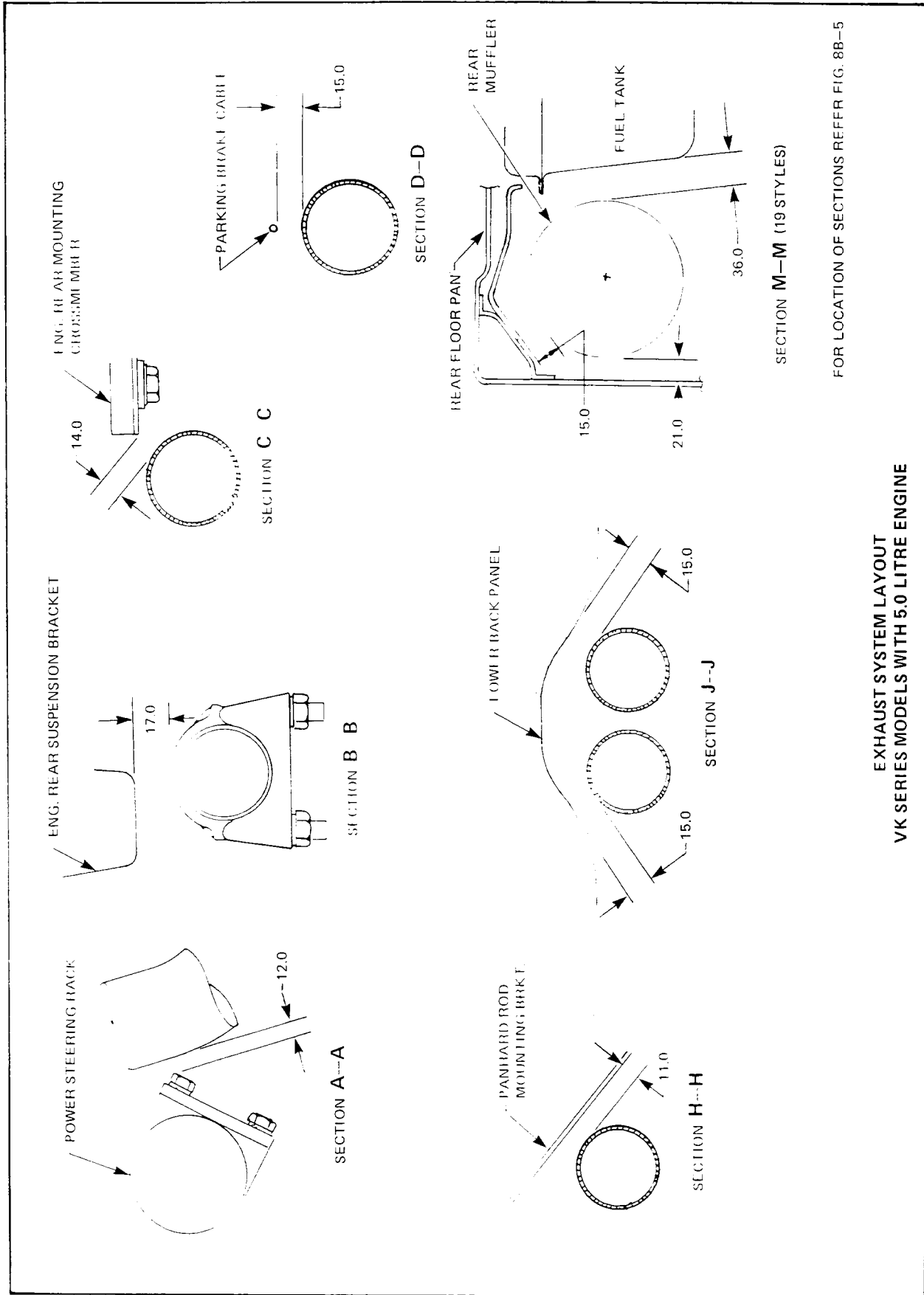

EXHAUST SYSTEM LAYOUT
VK SERIES MODELS WITH 5.0 LITRE ENGINE

Figure 8B-8

EXHAUST SYSTEM 8B-9

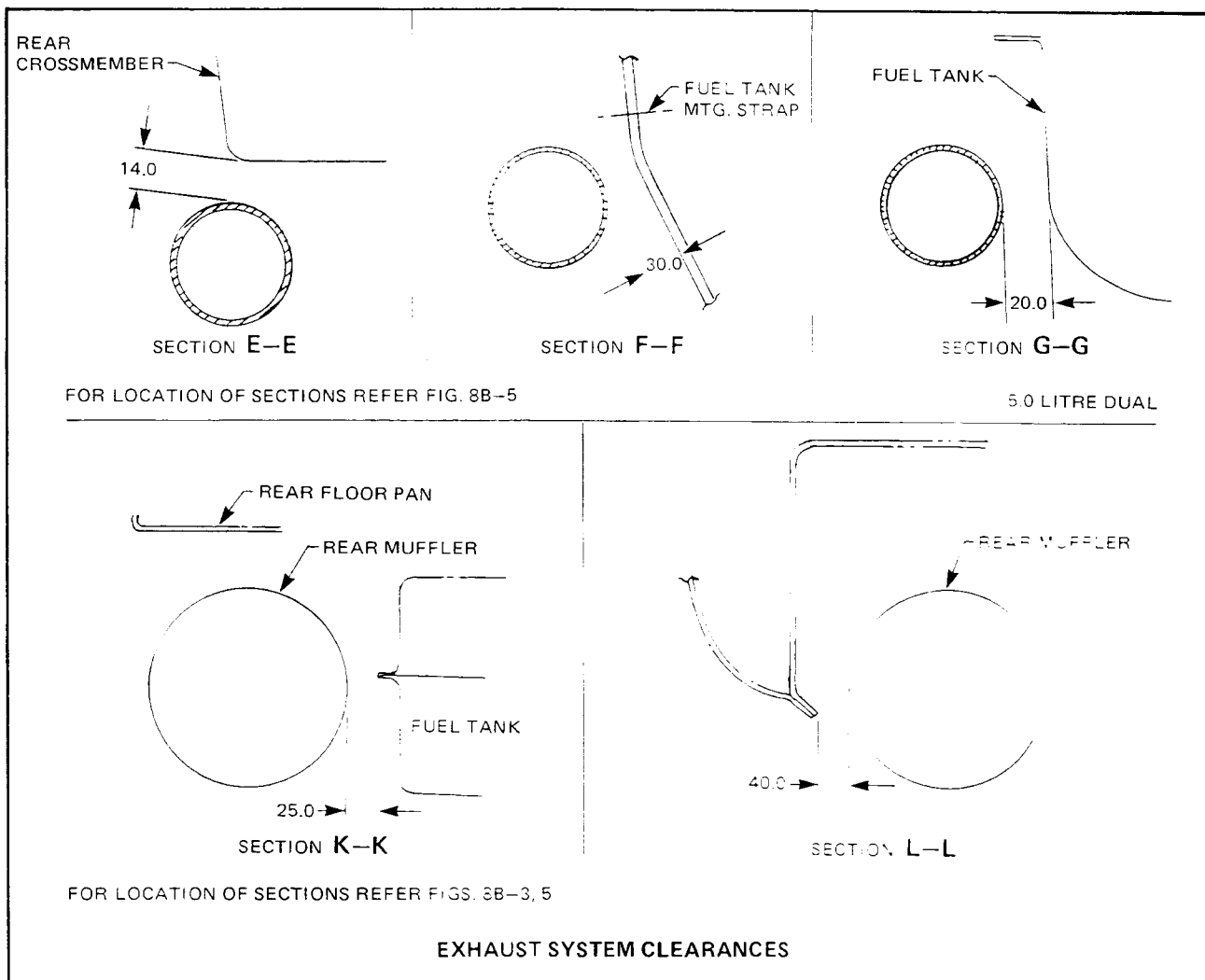

Figure 8B-9

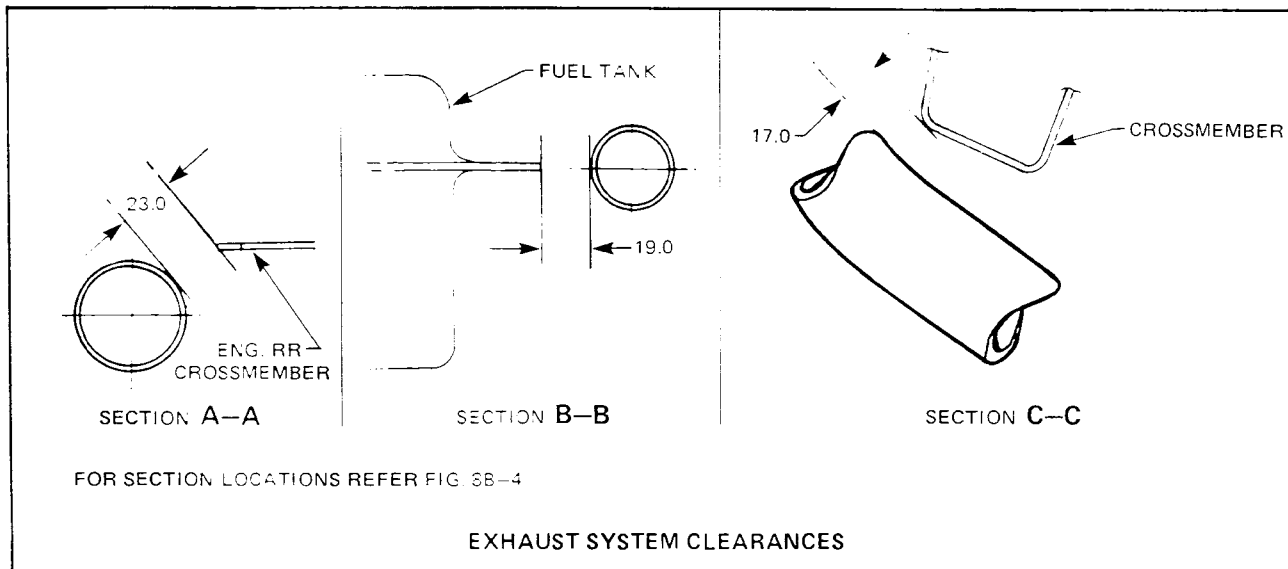
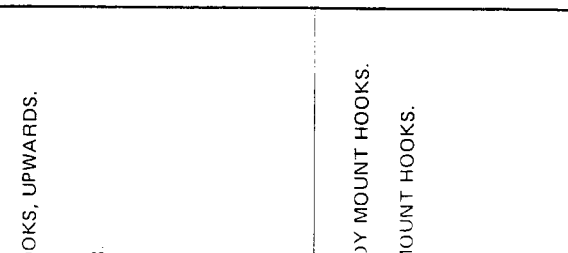
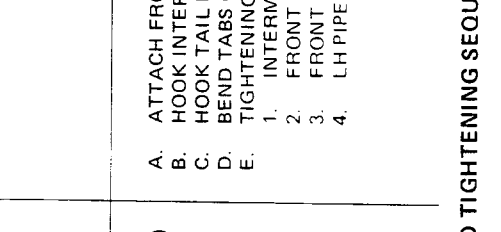
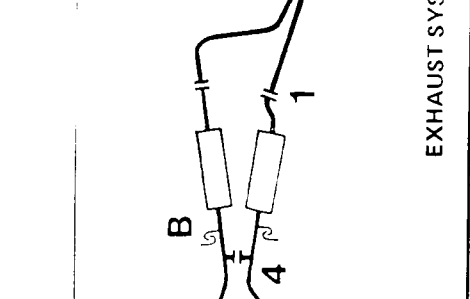

Figure 8B-10

8B-10 EXHAUST SYSTEM

EXHAUST SYSTEM	FITMENT & TIGHTENING SEQUENCE
<p>3.3 LITRE EST</p> 	<p>A. ATTACH FRONT PIPE LOOSELY TO MANIFOLD. B. HOOK FRONT PIPE TO BODY MOUNT HOOKS. C. HOOK TAIL PIPE TO BODY MOUNT HOOKS. D. BEND TABS, ON END OF ALL BODY MOUNT HOOKS, UPWARDS. E. TIGHTENING SEQUENCE. 1. INTERMEDIATE PIPE TO REAR MUFFLER. 2. FRONT PIPE TO INTERMEDIATE MUFFLER. 3. FRONT PIPE TO MANIFOLD.</p>
<p>3.3 LITRE EFI</p> 	<p>A. HOOK EXHAUST MUFFLER & PIPE ASM. TO BODY MOUNT HOOKS. B. HOOK TAIL PIPE TO BODY MOUNT HOOKS. C. BEND TABS UPWARDS ON END OF ALL BODY MOUNT HOOKS. D. TIGHTENING SEQUENCE. 1. REAR PIPE TO MUFFLER. 2. FRONT PIPE TO EXTRACTOR.</p>
<p>8 CYL. & N10</p> 	<p>A. ATTACH FRONT PIPES LOOSELY TO MANIFOLD. B. HOOK INTERMEDIATE FRONT PIPES TO BODY MOUNT HOOKS. C. HOOK TAIL PIPE TO BODY MOUNT HOOKS. D. BEND TABS ON END OF ALL BODY MOUNT HOOKS UPWARDS. E. TIGHTENING SEQUENCE. 1. INTERMEDIATE MUFFLERS TO INTERMEDIATE PIPES. 2. FRONT PIPES TO INTERMEDIATE FRONT PIPES. 3. FRONT PIPES TO MANIFOLD. 4. LH PIPE TO RH PIPE</p>

EXHAUST SYSTEM FITMENT AND TIGHTENING SEQUENCE

Figure 8B-11

EXHAUST SYSTEM 8B-11

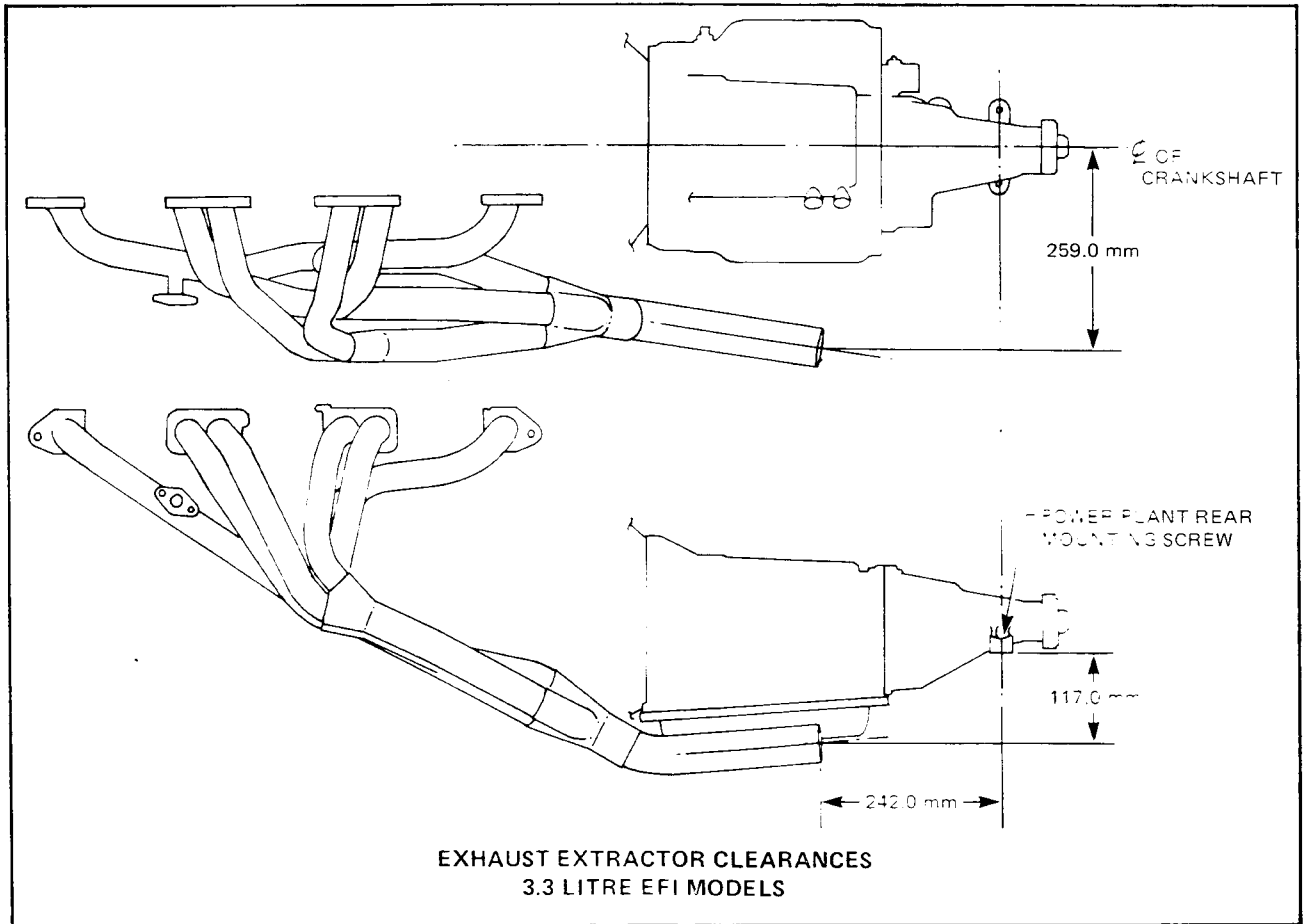

Figure 8B-12

3. SPECIFICATIONS

Type:		
Single	3.3 litre EST all models	
Single	3.3 litre EFI (with extractors)	
Dual	5.0 litre models	
Exhaust Pipe	50.8 mm	
Material	Seam welded steel tube	
Engine Pipe Diameter:		
Exhaust Extractor pipe d.a.	3 sizes	35 mm x 6 pipes 41.5 mm x 3 pipes 50.8 mm x 1 pipe
Intermediate pipe dia.	50.8 mm	
Muffler connecting pipe dia.	50.8 mm	
Tailpipe dia.	50.8 mm	

SECTION 9

STEERING

INDEX

Ref.	Subject	Page	Ref.	Subject	Page
1.	GENERAL DESCRIPTION	9-1	3.	TORQUE WRENCH SPECIFICATIONS	9-1
2.	SERVICE OPERATIONS	9-1			

1. GENERAL DESCRIPTION

The steering system for VK Series models carries over from VH Series models.

2. SERVICE OPERATIONS

For all service operations not noted in this Section refer to the VB Commodore Service Manual Part No. M38145 and the VH Commodore Service Manual Supplement Part No. M38731. On VK Series models there is fitted two types of lower steering shaft to intermediate steering shaft coupling clamp. Part No. 92021862 is identified by a date code stamp, refer to Fig. 9-1, Part No. 7809433 which does not have a date code stamp.

The clamp nut tightening torque specification has been revised, refer to specifications at end of this Section.

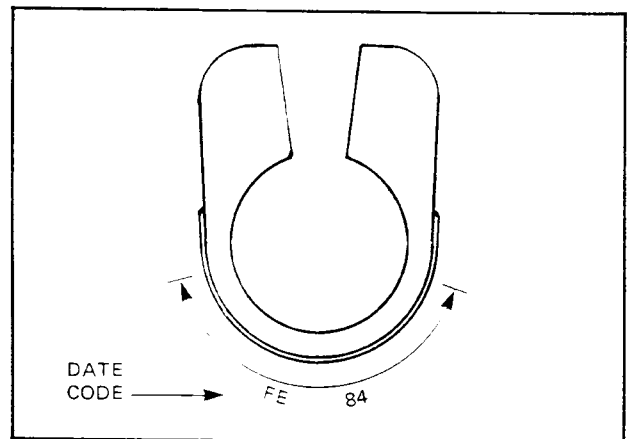

Figure 9-1

3. TORQUE WRENCH SPECIFICATIONS

Coupling Clamp Nut	42 – 48 Nm
--------------------------	------------

SECTION 10

WHEELS AND TYRES

INDEX

Ref.	Subject	Page	Ref.	Subject	Page
1.	GENERAL DESCRIPTION.....	10-1	3.	TORQUE WRENCH SPECIFICATIONS.....	10-2
2.	SPECIFICATIONS.....	10-2			

1. GENERAL DESCRIPTION

The tyre and wheel size on SL sedan models has been revised. The SL sedan has fitted a new 5.5 x 14 JJ steel wheel with a BR78S14 (P175/75 SR14) size tyre.

A new tyre P185/75 HR14 is now used on 5.0 litre models, this replaces the CR78 H14 tyre used on VH models.

All other wheel and tyre sizes remain the same as used on VH models.

The Calais has fitted, as standard equipment, a newly designed alloy road wheel. The alloy road wheel as used on VH SLE models now becomes optional equipment on Berlina models.

Service operations are as described in the Commodore VB and VH series service manuals.

10-2 WHEELS AND TYRES

2. SPECIFICATIONS

Steel Wheel:

Rim Width	5.5 JJ (On SL Sedan only) 6.0 JJ
Diameter	14 inch
Maximum permissible radial run-out	0.8 mm
Maximum permissible lateral run-out	1.0 mm
Offset	5.5 JJ X 14 – 37 mm 6.0 JJ X 14 – 43 mm

Alloy Wheels:

Rim Width	6.0 JJ
Diameter	15 inch
Maximum permissible radial run-out	0.25 mm
Maximum permissible lateral run-out	0.3 mm
Offset	44 mm

Dynamic Balancing:

Maximum permissible Wheel/Tyre out of balance	1.5 kg mm
Maximum permissible Tyre radial 1st harmonic force variation (Tyre only)	80 N

Maximum Load Rating (per Tyre):

BR 78 S14	525 kg
CR 78 S14	560 kg
CR 70 H14	600 kg
P205/60HR15	590 kg
P185/75HR14	530 kg
P185/75SR14	585 kg

TYRE DESIGNATION	RECOMMENDED COLD INFLATION PRESSURE – kPa			
	UP TO 3 PASSENGERS		UP TO MAX. HEAD	
	FRONT	REAR	FRONT	REAR
BR 78 S14	200	200	240	240
P175/75 SR14	200	200	240	240
P185/75 HR14	200	200	240	240
CR 78 S14	193	193	221	221
CR 70 H14	193	193	221	221
P205/60 HR15	200	200	221	221

3. TORQUE WRENCH SPECIFICATIONS

Road Wheel Securing Nuts	100 – 108 Nm
--------------------------	--------------

SECTION 12A

BATTERY & CABLES

INDEX

Ref.	Subject	Page	Ref.	Subject	Page
1.	GENERAL INFORMATION	12A-1	2.3	CHARGING BATTERIES	12A-4
1.1	DESCRIPTION	12A-1		Low Maintenance Types	12A-4
1.2	SERVICE NOTES	12A-1		Maintenance Free Types	12A-5
2.	SERVICE OPERATIONS	12A-2	2.4	VEHICLE WIRING, PERIODICAL CHECKS	12A-5
2.1	BATTERY, SERVICE	12A-2	2.5	DRY CHARGED BATTERY, STORE AND	
2.2	BATTERY, TEST	12A-2		ACTIVATE	12A-5
	State of Charge - Low		3.	DIAGNOSIS	12A-6
	Maintenance Type Batteries -		4.	SPECIFICATIONS	12A-6
	Hydrometer Test	12A-2			
	State of Charge -				
	Maintenance Free Batteries	12A-3			
	Load Test - All Batteries	12A-4			

1. GENERAL INFORMATION

1.1 DESCRIPTION

In all VK Series models, the 12 volt battery is located in the engine compartment behind the passenger side headlamp. The main battery cables are attached to the battery terminals by spring ring type clamps and the negative terminal is earthed to the vehicle body and the engine block.

Vehicles fitted with the 3.3 litre EST or EFI engine are equipped with a low maintenance 80 min/215 amp battery. (Optional equipment such as air conditioning and trip computer do not require a larger battery).

Vehicles fitted with the 5.0 litre engine, a 75 min/235 amp, maintenance free battery is fitted.

1.2 SERVICE NOTES

NOTE: The spring ring clamp battery terminals should be removed as shown in Fig. 12A-1. Never prise clamps off with a screwdriver or hammer. Push down as far as possible on the battery post when refitting battery leads.

CAUTION: Do not allow liquid from battery to contact eyes, skin, clothing or painted surfaces. Battery fluid contains sulphuric acid which causes injury and damage in the event of contact.

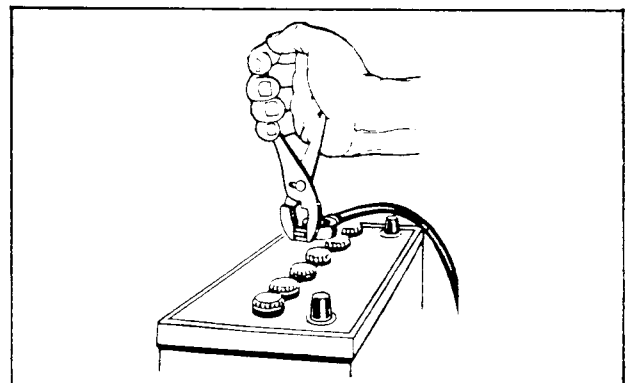

Figure 12A-1

12A-2 BATTERY & CABLES

2. SERVICE OPERATIONS

The following procedures should be used to service, test and recharge batteries. Unless these procedures are properly followed, good batteries may be replaced needlessly.

2.1 BATTERY, SERVICE

1. Check battery terminals and around battery area for corrosion deposits. Remove any deposits and treat with a solution of warm water and baking soda or ammonia, then rinse off with clean water. Smear battery posts and terminals with petroleum jelly to resist corrosion.
2. Check battery case and replace battery if case is cracked.
3. On all batteries except maintenance free batteries, check electrolyte level and carefully top up with distilled water as necessary to level of indicator. DO NOT OVERFILL.

NOTE: Normal battery water usage is less than 30 ml per 10,000 km, but may be more for long continuous running or high temperatures.

4. Check that battery is firmly secured by its clamping bracket.
5. Check that battery cable terminals are securely attached to battery posts and that cable insulation is not damaged or worn anywhere along cable. Check that cables do not have broken or frayed strands and that they are secure in their terminals.

2.2 BATTERY, TEST

STATE OF CHARGE - LOW MAINTENANCE TYPE BATTERIES - HYDROMETER TEST

NOTE:

- a. Ensure specific gravity of battery electrolyte has not been previously reduced to suit hot climate (explanatory tag specifying specific gravity of new electrolyte should be attached to battery in conspicuous position.)
 - b. If water has been added to battery, do not use hydrometer until electrolyte has been mixed by charging for at least 30 mins.
1. Hold hydrometer vertically and draw in sufficient liquid from battery cell to allow float to float freely with bulb fully released.
 2. Compensate reading for temperature by adding 0.004 for every 5°C that the electrolyte temperature exceeds 27°C, or subtracting 0.004 for every 5°C less than 27°C.

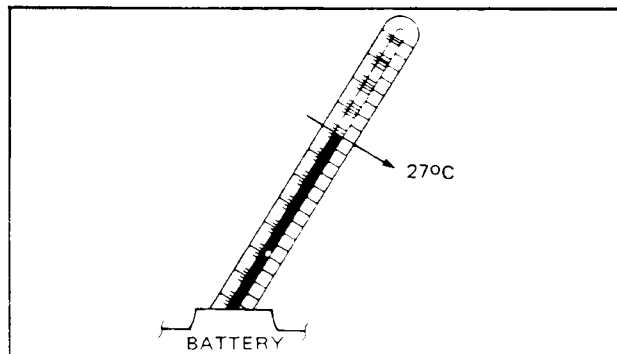

Figure 12A-2

3. Determine state of charge of battery using **temperature compensated** specific gravity and following table.

Battery Condition	Temperature Compensated Specific Gravity
Fully Charged	1.240 to 1.260
Recharge When Below	1.190
Fully Discharged	1.110 to 1.130

NOTE:

- a. If electrolyte specific gravity has been reduced for service in hot climates, typical temperature adjusted value of specific gravity below which battery should be recharged is 1.150.
- b. The specific gravity of a charged battery should not vary more than 0.025 between cells. Large variations indicate defective cells.

STATE OF CHARGE - MAINTENANCE FREE BATTERIES

NOTE: Maintenance free batteries operate on the same basic principle as other lead-acid batteries. As the battery is charged, lead sulphate in the plates is converted to lead in the negative plate, and to lead oxide in the positive plate. Also, the specific gravity of the sulphuric acid electrolyte increases.

The essential difference between low maintenance and maintenance free batteries, is in the lead alloy in the grids. When the battery is operated in the car at 14.0 V to 14.5 V, the rate of water loss is so low that topping up is unnecessary during the life of the battery, and the top can be permanently sealed. In the AC Delco Maintenance Free battery in the VK Series models, all of the acid is held within a highly porous separator material. Even when fully charged, the gases which are normally evolved from the water in the electrolyte are fully reabsorbed. Acid cannot leak at all. There is much less risk of explosion with this type of battery.

1. The state of charge of a sealed battery can be checked by measuring the OPEN CIRCUIT VOLTAGE. (O.C.V.)
2. Disconnect battery from all loads. Measure voltage across terminals with a voltmeter accurate to at least 0.1 volts. A digital meter is recommended.
3. Determine state of charge of battery using the following table, which is accurate if the battery has been off charge or discharge for several hours.

BATTERY CONDITION	OPEN CIRCUIT VOLTAGE
Fully Charged	Over 12.9 V
Recharge When Below	12.5 V
Fully Discharged	Less than 11.1 V

12A-4 BATTERY & CABLES

CAUTION: If battery is in a car which has just stopped, or has just come off charge or discharge, the O.C.V. will be higher or lower. Reliable readings will be obtained if battery is left standing for several hours, say overnight. For quick checks just off charge, connect a load of about 10 to 15 amps, such as headlights, for five to ten minutes. The O.C.V. will be close to the fully stabilized reading. A little experience, carefully noting if the voltage is varying during checks, and how quickly, will soon enable reliable measurements to be obtained.

LOAD TEST - ALL BATTERIES

1. Check battery state of charge as above. If under half charge, recharge before conducting this test.
2. Connect a voltmeter across battery terminals.
3. Start engine whilst reading voltmeter.
4. During starting at normal temperatures, indicated voltage of a fully charged battery should not fall below 10V. If voltage falls away quickly, battery is faulty. If battery and engine temperatures are below 5°C, voltage may be 0.5 to 1.0V lower. If one cell is faulty it will show up in this test by excessive gassing or overheating.

NOTE: Battery can be tested under load using a commercial battery tester as per manufacturer's instructions.

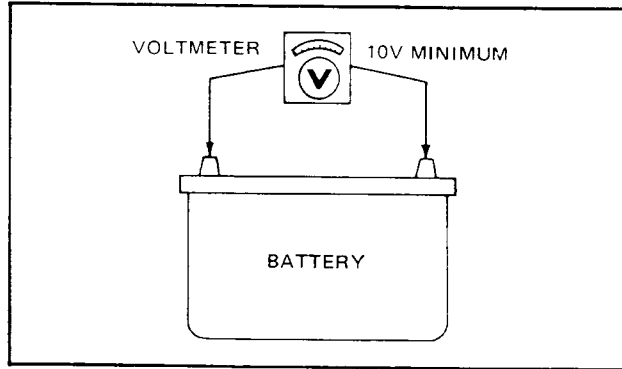

Figure 12A-3

2.3 CHARGING BATTERIES

Procedures for charging low maintenance and maintenance free batteries are basically the same. With both types, fully flat batteries can safely be boost charged, but care is necessary to avoid excessive current if the battery is over half charged, and particularly if it is almost fully charged. Slow charging is advisable if time permits.

CAUTION: During charging, an explosive hydrogen-oxygen gas mixture is released by the battery. Ensure there are no naked flames or electrical spark discharges in the vicinity of the battery during charging.

NOTE:

- a. Fast charging can substantially 'boost' a battery, but the fully charged condition can only be achieved by slow charging.
- b. Fast charging must **not** be used if:
 - i. Specific gravity readings are not uniform between battery cells, or are above 1.200 at the start.
 - ii. Electrolyte is discoloured with brown sediment.
 - iii. Either of the above two conditions develops after commencing fast charge.
 - iv. in the case of maintenance free batteries, if the O.C.V. is above 12.7 volts.
- c. The following tables assume 'constant current' type chargers. If 'constant voltage' charger is used, charge at 14.5 V to 15.0 V the battery will automatically regulate the current to a safe level.

LOW MAINTENANCE TYPES

1. Remove battery from vehicle and remove vent caps. Rest caps loosely in openings to prevent acid mist escaping.

BATTERY & CABLES 12A-5

- Connect battery, with correct polarity, to charging apparatus and set charging current according to the following table.

	Initial Charging Current	Time for Fully Discharged Battery	Time for Partly Discharged Battery
Slow Charge	4A approx.	24 hrs. max.	Proportional to the charge at the start
Fast Charge	35A approx.	2 hrs. max.	

- After a few minutes, check electrolyte specific gravity (as per operation 2.2 in this section) and colour (see note iii).
 - Monitor electrolyte temperature during charging procedure. If temperature reaches 55°C, switch off charging current and allow battery to cool. Reduce charging current to prevent subsequent overheating.
- NOTE:** A fast charged battery can be brought to the fully charged condition by slow charging for a few hours. During the last few hours on charge the current should be 1.0 amp or less.
- Check voltage and electrolyte specific gravity once per hour. Slow charging is completed when there is no change in voltage or electrolyte specific gravity over a three hour period.

CAUTION: Charging at over the recommended times or currents can significantly reduce battery life.

MAINTENANCE FREE TYPES

- Remove battery from vehicle.
- Connect battery, with correct polarity to charging apparatus and set charging current according to the following table.

	Initial Charging Current	Time for Fully Discharged Battery	Time for Partly Discharged Battery
Slow Charge	4A approx.	24 hrs. max.	Proportional to the charge at the start
Fast Charge	35A approx.	2 hrs. max.	

NOTE: If the O.C.V. was very low, less than 10.0 V, the initial charge current may be quite low. The current should increase after a short time at the charge voltage.

- Monitor battery temperature. If the battery feels noticeably warm, switch off charging current and allow battery to cool. Reduce charging current to prevent subsequent overheating. A fast charged battery can be brought to the fully charged condition by slow charging for a few hours. During the last few hours on charge, the current should be 1.0 amp or less and the voltage 15.0 V maximum.
- Check voltage and current once per hour, as charge approaches completion. Slow charging is completed when **both** voltage and current are constant over a three hour period.

CAUTION: Refer note under low maintenance type regarding overcharging.

- Refit battery to vehicle. Operate starter motor for approximately 10 seconds, to remove surface charge from battery.
- Load test battery as previously described in this Section.

2.4 VEHICLE WIRING, PERIODICAL CHECKS

To ensure efficient operation of electrical system and to safeguard against damage, the following checks should be carried out periodically:

- Check that all wires are held securely by their respective retainer clips.
- Check wires for chaffing or damaged insulation and repair or replace as necessary.
- Check that wire terminals and fuses are secure and that fuses are as specified at end of Section.

2.5 DRY CHARGED BATTERY, STORE AND ACTIVATE

Dry charged batteries are fully charged when manufactured and contain no electrolyte until activated for service. The dry charged battery is completely sealed and can be stored indefinitely with no servicing until activated. To activate a dry charged battery:

- Remove vent caps and add electrolyte of 1.265 specific gravity to each cell until correct level is reached.
- Several minutes after activating battery, check electrolyte level and add more electrolyte (not water) as necessary.

NOTE:

- After dry charge battery is activated, it becomes a 'wet' battery and only water should be added in subsequent servicing.
- Although a dry charge battery can be put into service immediately after activation, the following tests are recommended:
 - After adding electrolyte, check open circuit terminal voltage of battery. If less than 10V, replace battery.
 - Check specific gravity of electrolyte in each cell. If any temperature corrected reading (see operation 2.2 in this section) shows more than a 0.030 drop from initial specific gravity of electrolyte, slow charge battery before use as per operation 2.3 in this Section.
 - Check cells for violent gassing and if detected, slow charge battery before use.

12A-6 BATTERY & CABLES

3. DIAGNOSIS

CAUSE	SYMPTOM			
	Electrical Systems 'Dead'	Battery Dead	Battery Uses Excessive Water	Excessive Corrosion Around Battery
Battery Overfilled				X
Battery Underfilled		X		
Battery Cracked		O	O	O
Battery Old/Faulty	O	X		O
Generator Faulty		O		
Voltage Regulator Faulty		O	X	
Ignition Switch Faulty	O			
Faulty or Worn Wire/Cable	O			
Bad Connection(s)	O			

- O Indicates possible cause.
 X Indicates more probable cause.

4. SPECIFICATIONS

BATTERY:

Rated Voltage	12 volts
Capacity	Reserve/Cold Cranking
Vehicles with 3.3 litre EFI or EST	80 min./215 amp
Vehicles with 5.0 litre engine	75 min./235 amp

NOTE: Specified ratings when tested in accordance with Australian Standard AS 2149 – 1980.

SECTION 12B

LIGHTING SYSTEM

INDEX

Ref.	Subject	Page	Ref.	Subject	Page
1.	GENERAL DESCRIPTION	12B-1	2.3	HEADLAMP SWITCH	12B-4
2.	SERVICE OPERATIONS	12B-2		Remove	12B-4
2.1	REAR TAIL LAMP (SEDAN)	12B-2		Reinstall	12B-4
	Remove	12B-2	2.4	DASH LIGHTS DIMMER SWITCH	12B-5
	Reinstall	12B-3		Remove	12B-5
2.2	LICENCE PLATE LAMP SOCKET			Reinstall	12B-5
	(SEDAN)	12B-4	3.	SPECIFICATIONS	12B-5
	Remove	12B-4			
	Reinstall	12B-4			

1. GENERAL DESCRIPTION

The lighting system for VK Series models carries over from VH Series models except where noted in this Section.

On all models, the front turn signal lamp assemblies have a clear crystal appearance lens, with an amber inner filter for amber illumination.

On all sedan models, there is a new style rear tail lamp lens and tail lamp extension moulding, refer Fig. 12B-1.

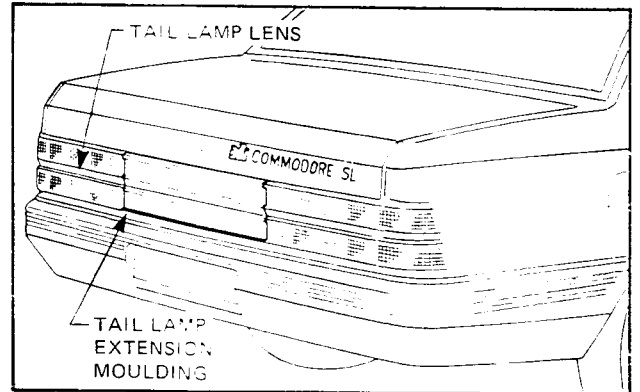

Figure 12B-1

On all sedan models, the rear licence plate is illuminated by a new licence plate lamp socket assembly and is attached to the bumper, refer Fig. 12B-2.

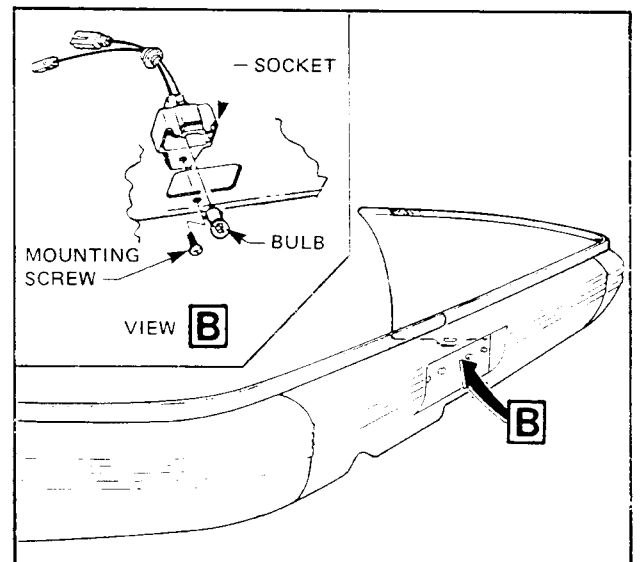

Figure 12B-2

12B-2 LIGHTING SYSTEM

On station wagon models, the rear licence plate illumination is by two Camira sedan style licence plate lamp assemblies, mounted on the rear bumper bar. Refer Fig. 12B-2A.

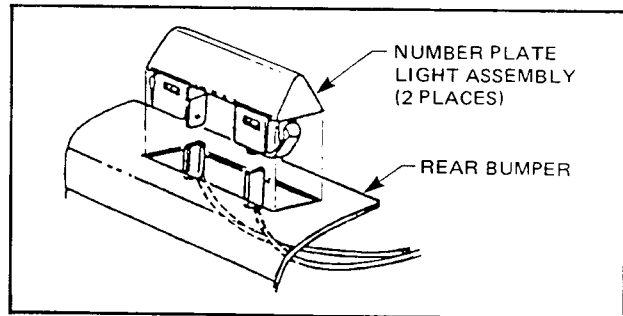

Figure 12B-2A

2. SERVICE OPERATIONS

Service operations for the VK Series lighting system carry over from VH Series models, except where noted in this Section.

2.1 REAR TAIL LAMP (SEDAN)

REMOVE

1. From inside boot, remove globe sockets from the rear tail lamp assembly that is to be removed, Fig. 12B-3.

NOTE: To remove the globe sockets on the passenger side tail lamp, remove the spare wheel.

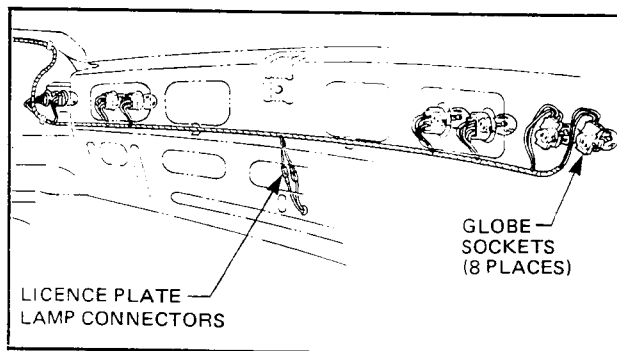

Figure 12B-3

The two outer globe sockets on the passenger side tail lamp are removed by depressing the lever (arrowed in Fig. 12B-4) and twist the globe socket in the direction of the REMOVE arrow.

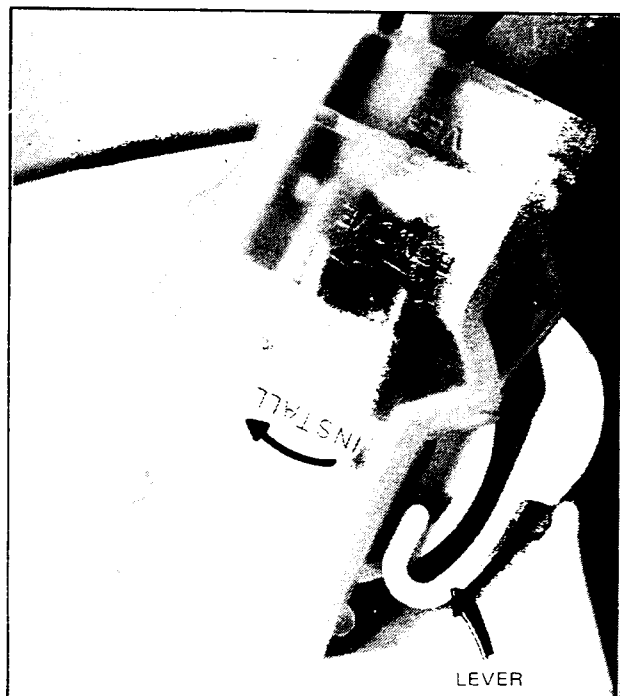

Figure 12B-4

LIGHTING SYSTEM 12B-3

2. Remove the four screws around the outside of the tail lamp extension moulding, refer Fig. 12B-5.

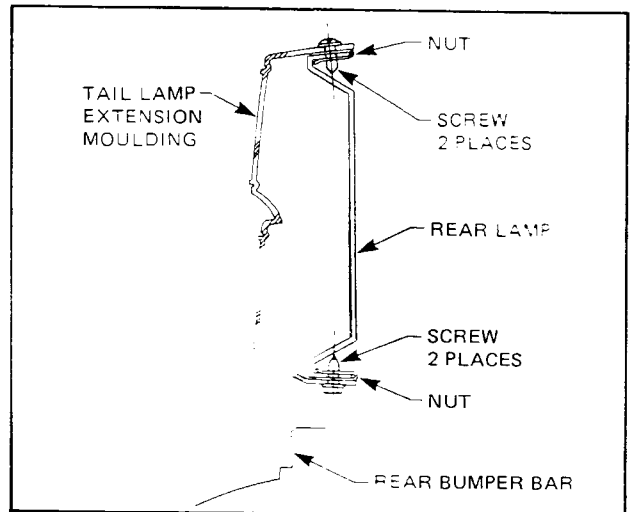

Figure 12B-5

3. From inside the boot, remove the two nuts securing the tail lamp extension moulding mounting brackets to the rear end panel, refer Fig. 12B-6. Remove extension.

NOTE: On Calais models, it will be necessary to remove the boot carpet to reveal the two nuts.

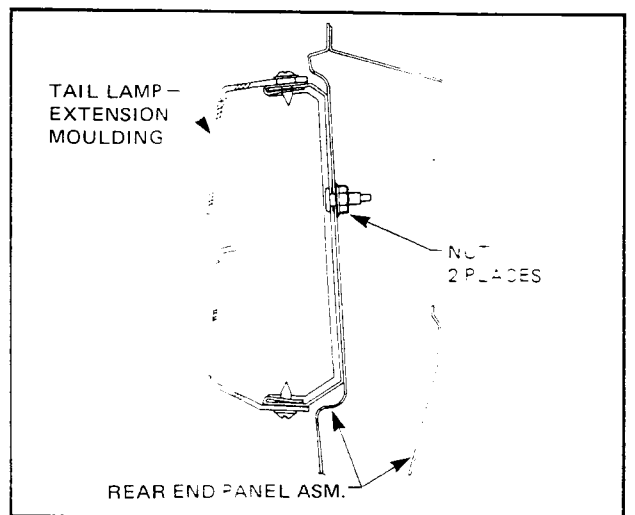

Figure 12B-6

4. Remove the five tail lamp mounting screws from inside the boot, refer Fig. 12B-7, remove tail lamp assembly.

REINSTALL

Installation is reversal of removal procedures. Check lamp operation.

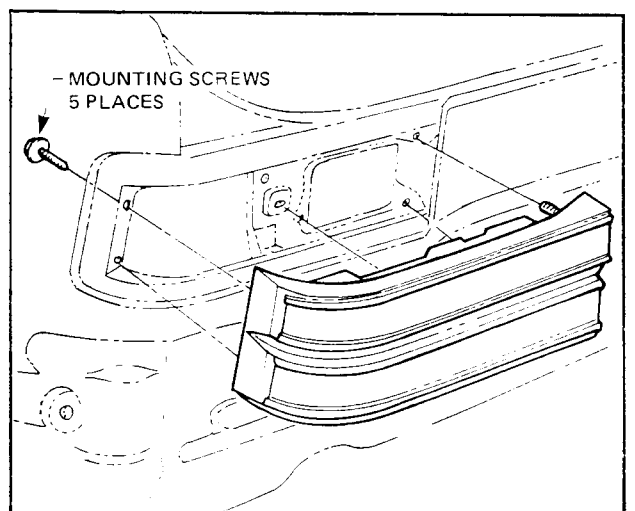

Figure 12B-7

12B-4 LIGHTING SYSTEM

2.2 LICENCE PLATE LAMP SOCKET (SEDAN)

REMOVE

1. Disconnect battery earth lead.
2. From inside boot, disconnect licence plate lamp socket wiring connectors, refer Fig. 12B-8.
3. Push grommet and wiring connectors out towards the rear of the vehicle.
4. Remove rear bumper bar as per service instruction 1.3, Section 1D of this supplement.

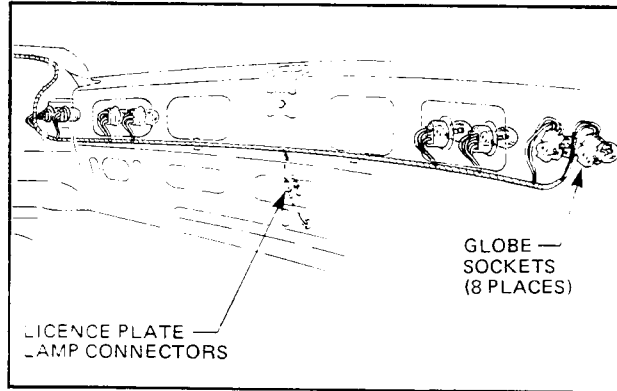

Figure 12B-8

5. Remove screw holding lamp socket to bumper bar, refer Fig. 12B-9 and remove socket.

NOTE: Licence plate globe replacement is by pushing globe against spring in the socket and twisting globe, which releases it from the socket.

REINSTALL

Installation is reversal of removal procedures. Ensure licence plate lamp wiring grommet is fitted correctly. Check lamp operation.

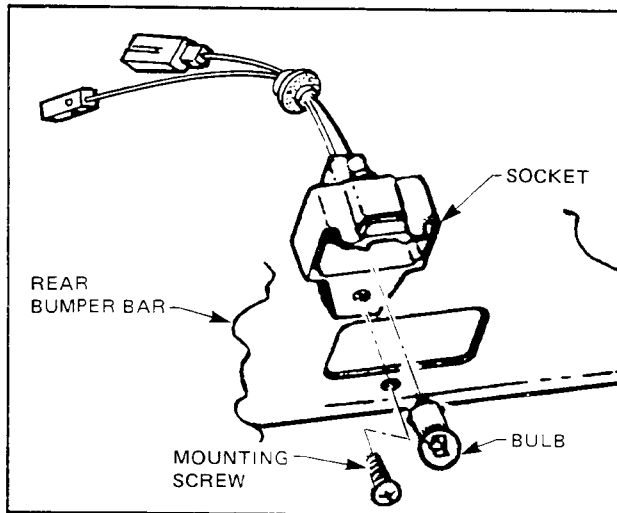

Figure 12B-9

2.3 HEADLAMP SWITCH

REMOVE

1. Remove cover from lower right hand dash panel, refer Fig. 12B-10.
2. Reach up behind switch through cavity in lower right hand dash panel, and pull wiring harness connector from switch.
3. The light switch is a snap fit into the instrument facia. Push out light switch from behind facia.

REINSTALL

Installation is reversal of removal procedure. Check light switch operation.

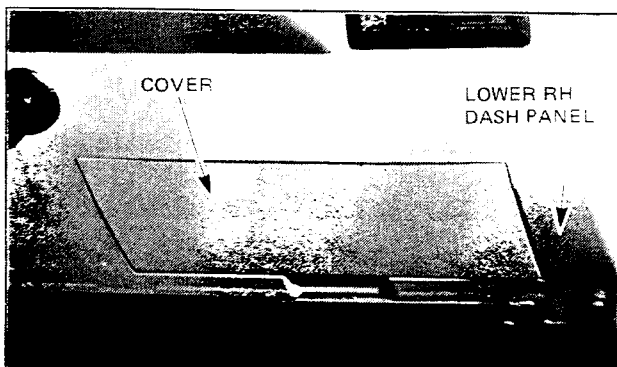

Figure 12B-10

2.4 DASH LIGHTS DIMMER SWITCH

REMOVE

1. Remove headlamp switch as per service operation 2.3.
2. Through the hole vacated by the headlamp switch, remove the two switch mounting screws, refer Fig. 12B-11.
3. Pull the switch back and disconnect wiring connector, withdraw switch.

REINSTALL

Installation is reversal of removal procedures. Check operation of dash lights.

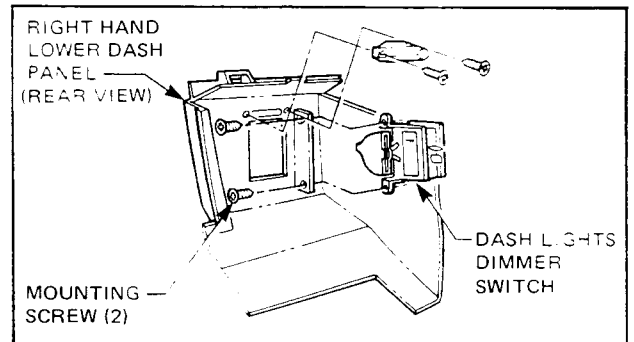

Figure 12B-11

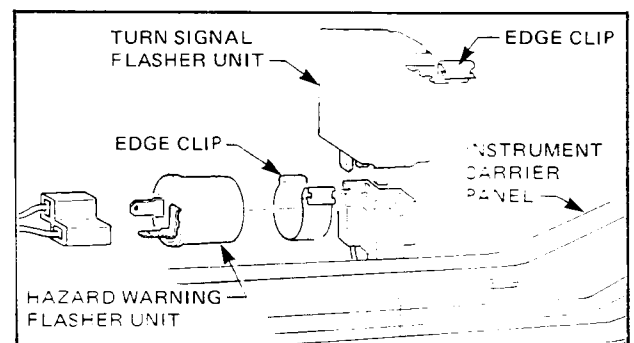

Figure 12B-12

3. SPECIFICATIONS

TURN SIGNAL FLASHER UNIT:

Make
 Operation
 Location

Hella
 60/120 flashes per minute with audible sound.
 Instrument carrier panel. Refer Fig. 12B-12
 Access is gained by removing cover from lower
 right hand dash panel, refer Fig. 12B-10.

HAZARD WARNING FLASHER UNIT:

Make
 Operation
 Location

Delco
 60/120 flashes per minute.
 Instrument carrier panel. Refer Fig. 12B-12.
 Access is gained by removing cover from lower
 right hand dash panel, refer Fig. 12B-10.

RATING OF GLOBES:

Headlamp
 Instrument Panel Illumination

60/55 watt Halogen
 1.2 watt Push-In

ALL SWITCH & CONTROL ILLUMINATION:

Generator Charge Indicator
 Back Up and Turn Signal Lamps
 Dome Lamp
 Engine and Rear Compartment
 Dome Lamp - Calais
 Front Reading Lamp - Calais
 Interior Rear Quarter Lamps - Except SL model
 Front Park Lamp
 Glove Box Lamp
 Licence Plate Lamp - Sedan
 Licence Plate Lamp - Station Wagon
 Stop/Tail Lamp

2 c.p.
 21 watt Bayonet
 10 watt Festoon
 10 watt Festoon
 10 watt Festoon
 12 watt Bayonet
 10 watt Festoon
 4 watt Bayonet
 5 watt Festoon
 10 watt Bayonet
 3 watt Bayonet (2 off)
 21.5 watt Bayonet

SECTION 12C

INSTRUMENTS, GAUGES, WINDSHIELD WIPERS/WASHERS

INDEX

Ref.	Subject	Page	Ref.	Subject	Page
1.	GENERAL DESCRIPTION	12C-1	2.2	INSTRUMENT CLUSTER - MECHANICAL INSTRUMENTS	12C-14
1.1	MECHANICAL INSTRUMENT ASSEMBLY	12C-1		Remove.....	12C-14
1.2	ELECTRONIC INSTRUMENT ASSEMBLY..	12C-3		Reinstall	12C-14
	Warning Lamp Panel.....	12C-3	2.3	INSTRUMENT CLUSTER - ELECTRONIC INSTRUMENTS	12C-14
	Alpha Warning Display	12C-4		Remove.....	12C-14
	Temperature Gauge.....	12C-5		Reinstall	12C-15
	Fuel Gauge.....	12C-5	2.4	MECHANICAL INSTRUMENTS	12C-15
	Speedometer and Digital Speed Displays	12C-6		Disassembly.....	12C-15
	Tachometer	12C-6		Reassembly	12C-17
	Odometer and Trip Meter	12C-6	2.5	INSTRUMENT TESTING	12C-17
	Trip Computer.....	12C-7		Speed Sender	12C-17
	Automatic Instrument Display Dimming	12C-7	2.6	FUEL GAUGE SENDER UNIT	12C-18
1.3	TOUCH SWITCHES - MECHANICAL & ELECTRONIC INSTRUMENT ASSEMBLIES.....	12C-8		Remove.....	12C-18
1.4	TRIP COMPUTER	12C-8		Fuel Gauge Sender Unit Diagnosis	12C-18
	General Description.....	12C-8		Reinstall	12C-19
	Function Description.....	12C-9		Fuel Tank	12C-19
1.5	TRIP COMPUTER COMPONENTS.....	12C-11	2.7	SPEEDOMETER GEAR CHART	12C-23
	Fuel Flow Sensor.....	12C-11	3.	WINDSHIELD WIPER AND WASHER	12C-24
	Fuel Level Sensor	12C-11	3.1	GENERAL DESCRIPTION	12C-24
	Electronic Control Module.....	12C-11	3.2	SERVICE OPERATIONS	12C-24
	Speed Sender	12C-12	3.3	WIPER DWELL CONTROL SWITCH	12C-24
2.	SERVICE OPERATIONS	12C-13		Remove.....	12C-24
2.1	TOUCH SWITCH CONTROL PANEL	12C-13		Reinstall	12C-24
	Remove.....	12C-13			
	Test	12C-13			
	Reinstall	12C-13			

1. GENERAL DESCRIPTION

All VK Series models have a redesigned instrument assembly.

1.1 MECHANICAL INSTRUMENT ASSEMBLY

SL models have a speedometer, fuel consumption indicator, voltmeter, temperature, oil pressure and fuel gauges. An analog clock is situated in the middle of the instrument cluster. Refer Fig. 12C-1.

Below the instrument cluster is the warning lamp panel incorporating turn indicator, charge indicator lamp, park brake and brake failure lamps, low oil pressure warning lamp, high beam indicator and EST diagnostic lamp.

On Berlina models the assembly is the same except for the addition of a tachometer instead of the fuel consumption indication.

A control panel to the left of the instrument cluster contains touch switches for the rear window demister and other options for both Berlina and Commodore SL models. Refer Fig. 12C-1.

12C-2 INSTRUMENTS, GAUGES, W'SHIELD WIPERS/WASHERS

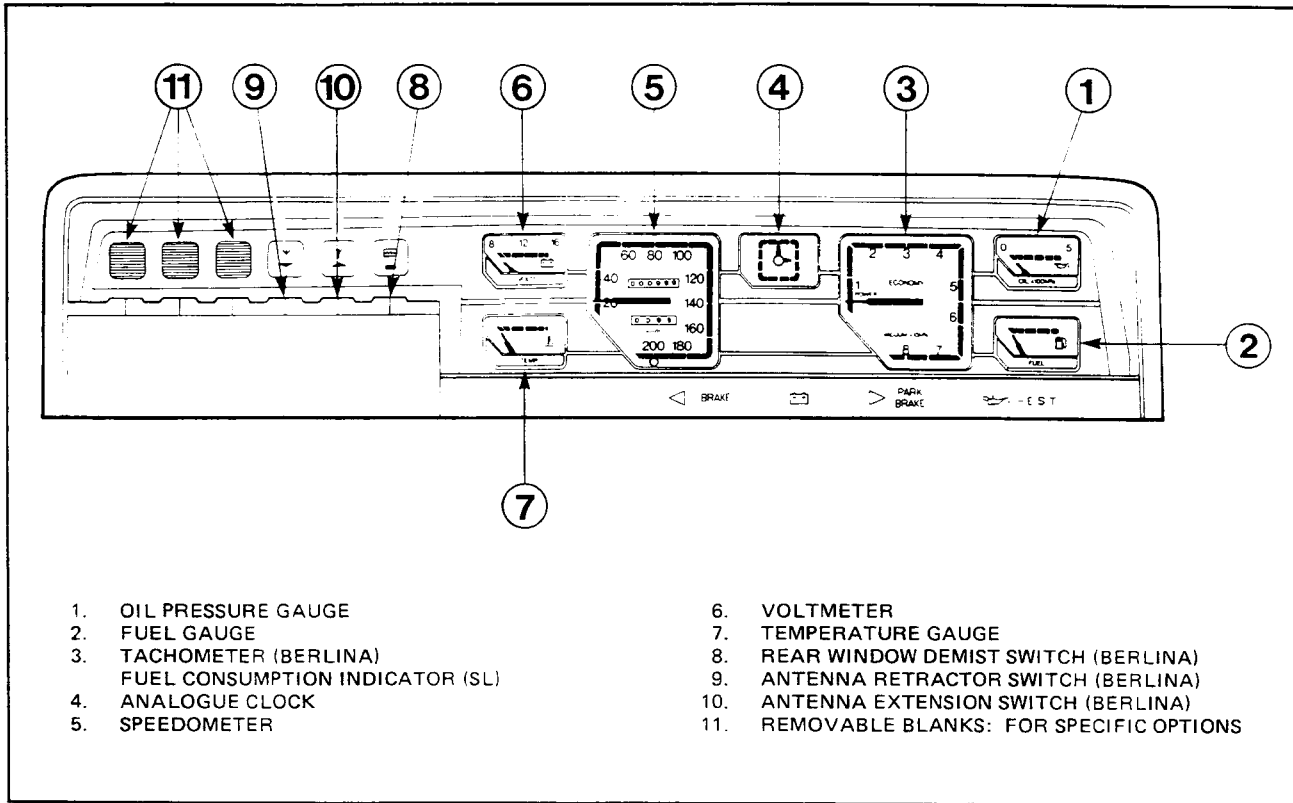

Figure 12C-1

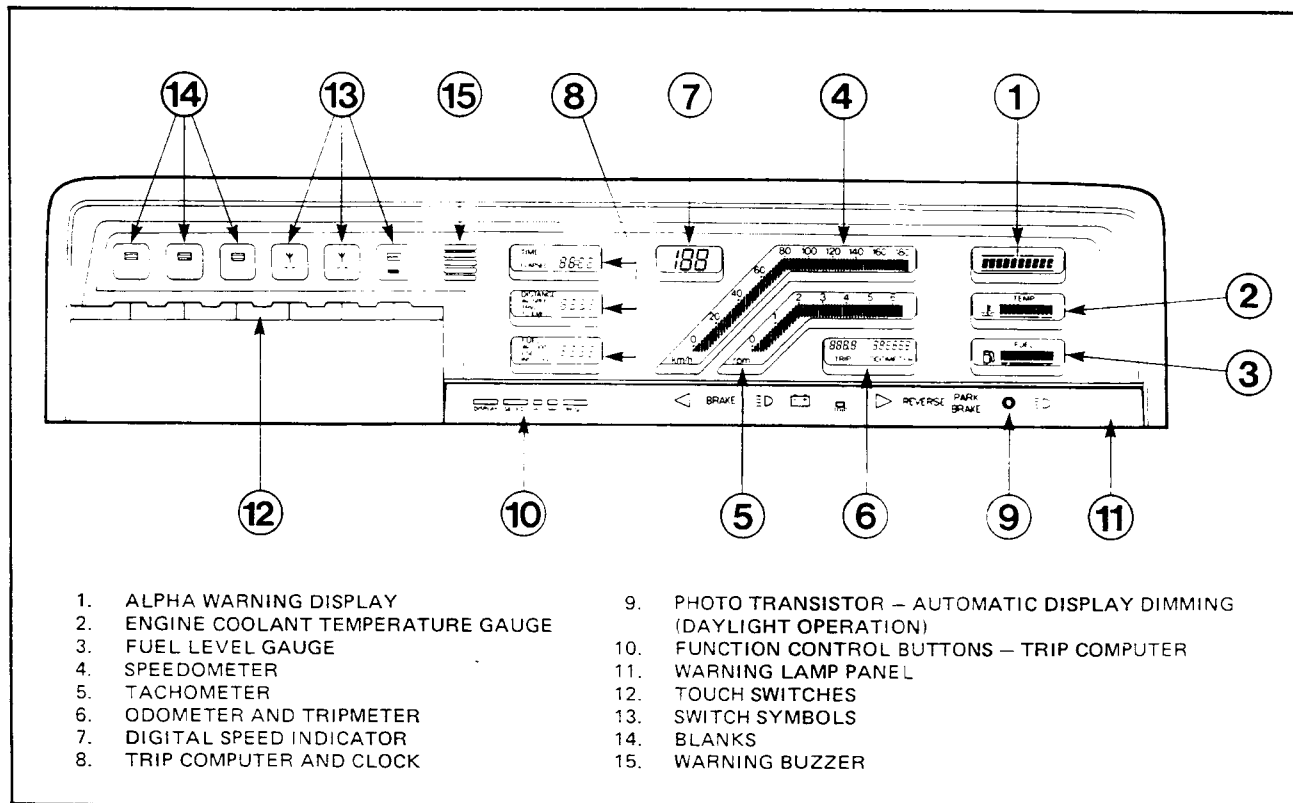

Figure 12C-2

INSTRUMENTS, GAUGES, W'SHIELD WIPERS/WASHERS 12C-3

1.2 ELECTRONIC INSTRUMENT ASSEMBLY

Calais models have a new Electronic Instrument assembly.

The instrumentation is fully electronic and vacuum fluorescent, featuring trip computer and automatic display dimming.

Electronic instruments feature a combination of bar graphics in green light for speedometer, tachometer, fuel and temperature gauges, with digital displays for speedometer, odometer and trip meter.

The Electronic Instrument Assembly, as shown in Fig. 12C-2, consists of the following components:

1. Alpha Warning Display
2. Engine Coolant Temperature Gauge
3. Fuel Level Gauge
4. Speedometer
5. Tachometer
6. Odometer and Trip Meter
7. Digital Speed Indicator
8. Trip Computer and Clock
9. Photo Transistor - Automatic Display Dimming (daylight operation) Manual Rheostat Control (night operation).
10. Function Control Buttons - Trip Computer
11. Warning Lamp Panel
12. Touch Switches
13. Switch Symbols
14. Blanks
15. Warning Buzzer

WARNING LAMP PANEL

The warning lamp panel is located along the bottom edge of the instrument cluster.

The warning lamp panel contains warning lamps for:

1. Battery Charge
2. Brake Failure
3. Park Brake
4. Left Hand Turn Indicator
5. Right Hand Turn Indicator
6. Headlights on (with ignition off)
7. High Beam Indicator
8. Reversing Indication Lamp

Warnings are displayed and a buzzer sounded for various component functions.

Function	Warning Lamp	Audible Warning
Battery Charge	YES	NO
Brake Failure	YES	2 BEEPS
Park Brake	YES	2 BEEPS (if car moving above 5 k/hr)
Right Hand Indicator	YES	NO
Left Hand Indicator	YES	NO
Reversing Warning	YES	NO

The 2 beeps will sound in a half second time interval.

12C-4 INSTRUMENTS, GAUGES, W'SHIELD WIPERS/WASHERS

ALPHA WARNING DISPLAY

The alpha warning display comprises ten, 14 segment alpha numeric character displays. It is situated in the right hand top corner of the instrument cluster.

When the ignition is first switched 'on' and the motor is not running, the warning monitor displays 'SEAT BELT' continuously, until the motor is started, after which the message will display for a further 10 seconds. Refer Fig. 12C-3.

If another message is waiting to be displayed after the motor has started, the 'SEAT BELT' warning will display only for 5 seconds, allowing the other messages to be displayed.

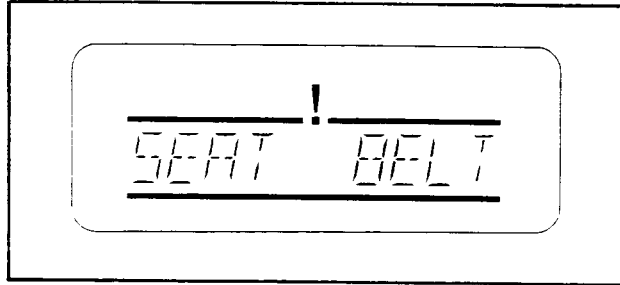

Figure 12C-3

In the situation that more than one warning occurs at once, the messages cycle through, each for 10 seconds and a 1 second gap between each message and in order of priority. The priority order being:

1. OIL ALERT
2. ENGINE HOT
3. LO COOLANT
4. LO FUEL

Refer Fig. 12C-4.

If 'ENGINE HOT' is displayed and 'LO COOLANT' is queued for display and then suddenly an 'OIL ALERT' fault occurs, then the 'OIL ALERT' warning will jump the queue and take precedence over the other warnings.

When an alpha warning is displayed, it is accompanied by an audible (5 beep) warning. This audible warning will only occur once for the initial display of each individual message and every time the ignition is switched on until the source of the fault is remedied.

Every time an alpha warning is first displayed, the audible warning will sound 5 beeps in two seconds.

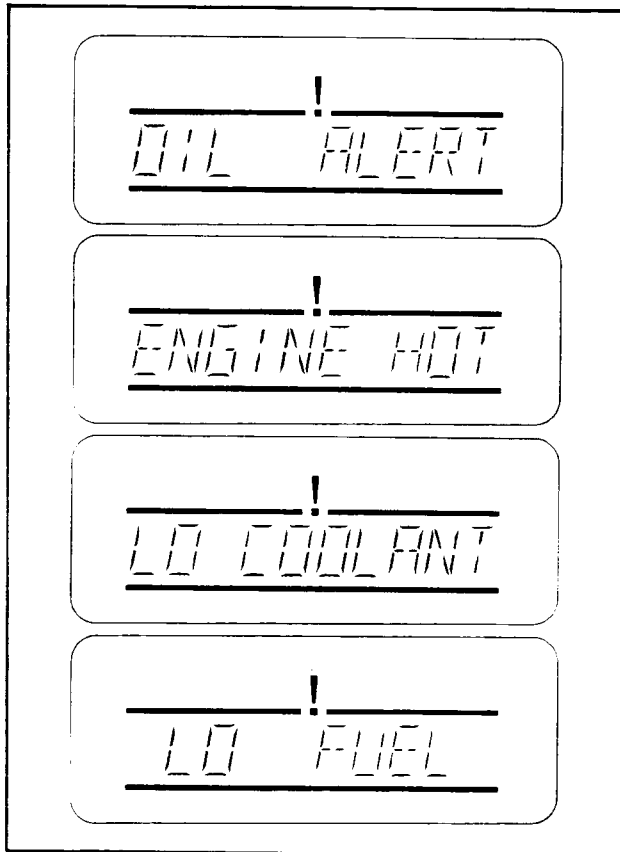

Figure 12C-4

When there is no warning message evident, the word 'MONITOR' is displayed. Refer Fig. 12C-5.

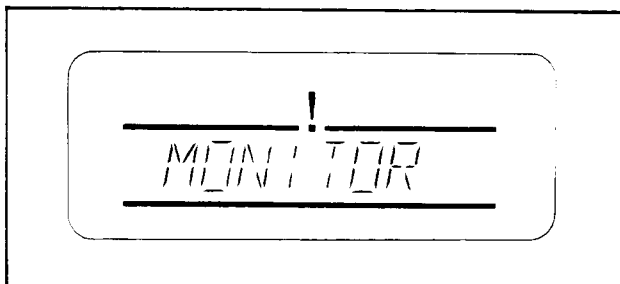

Figure 12C-5

INSTRUMENTS, GAUGES, W'SHIELD WIPERS/WASHERS 12C-5

TEMPERATURE GAUGE

The temperature gauge, refer Fig. 12C-6, is located between the alpha warning display and fuel gauge on the right hand side of the instrument cluster.

The engine coolant temperature display consists of 13 segment bars, the last three bars from the right are red and the remaining are green.

With an increase in coolant temperature, the bars light up, one at a time, from left to right. When the red zone is reached, these bars light up progressively and remain alight so that at maximum temperature, all the red bars are alight.

When the coolant temperature is sufficient to cause the first of the red bars light up, the alpha warning displays 'ENGINE HOT' and the audible warning sounds 5 beeps.

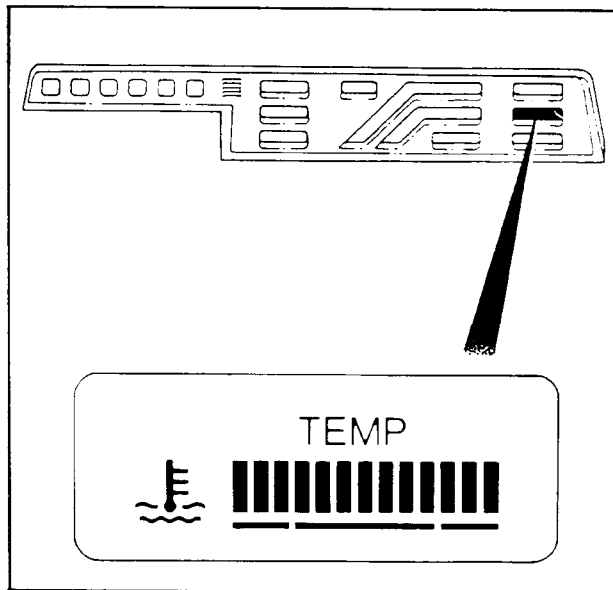

Figure 12C-6

FUEL GAUGE

The fuel gauge, refer Fig. 12C-7, is located in the lower right hand corner of the instrument cluster.

The fuel gauge is a progressive bar display in which the bars light up to indicate the level of fuel in the tank.

The first three bars from the left of the gauge are red, whilst the remaining bars are green. As the fuel level drops below 10.5 litres (approximately) and the last left hand green bar goes out, a 'LO FUEL' warning is displayed on the alpha warning display. An audible warning is also sounded, consisting of 5 beeps. When the last red bar goes out, there is less than 1.5 litres of fuel left in the tank. There is approximately 3 litres of fuel in the tank for each lighted red or green bar.

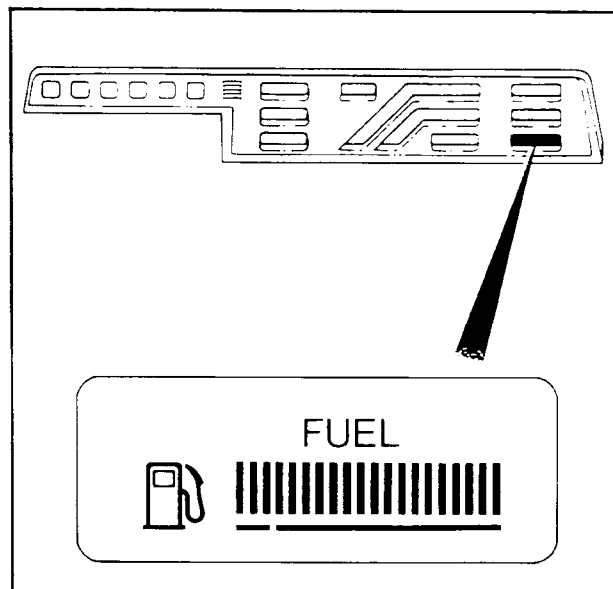

Figure 12C-7

12C-6 INSTRUMENTS, GAUGES, W'SHIELD WIPERS/WASHERS

SPEEDOMETER AND DIGITAL SPEED DISPLAYS

The speedometer, refer Fig. 12C-8, is situated in the centre section of the instrument cluster. It has a green light bar graph commencing at 0 and finishing at 180 km/hr.

When the ignition is switched on, all the digits light up. When the vehicle is moving, the bar graph lights up to indicate vehicle speed.

To the left of the speedometer is a digital speed display showing vehicle speed. The last digit of the digital speed display does not change more than once every half second, so as to guarantee good legibility. When the vehicle is stationary and the ignition is on, the digital display will indicate '0'.

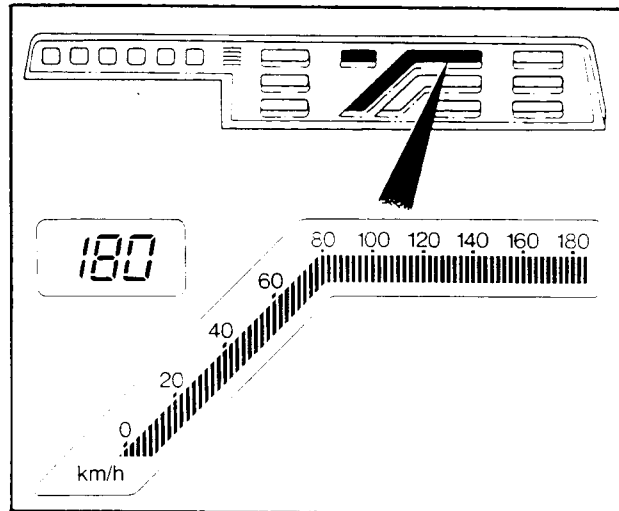

Figure 12C-8

TACHOMETER

The tachometer, refer Fig. 12C-8A, is situated below the speedometer in the centre of the instrument cluster.

The digits 0 to 7 light up whenever the ignition is switched on. The green bar graph lights up as an indication of engine speed.

The colour of the bar graph above 5500 rpm is red, indicating engine speed above this level should not be maintained.

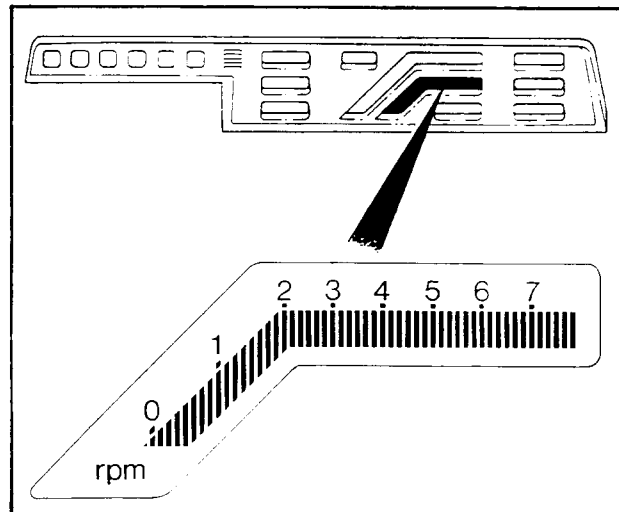

Figure 12C-8A

ODOMETER AND TRIP METER

The odometer, refer Fig. 12C-9, is a seven segment 6 digit display and together with the seven segment 4 digit trip meter display, is situated below the tachometer.

The odometer indicates distance travelled in one kilometer units from 1 to 999,999 kilometers.

The trip meter indicates distance travelled in tenths of a kilometer up to 999.9 kilometers. Below the trip meter is a reset button.

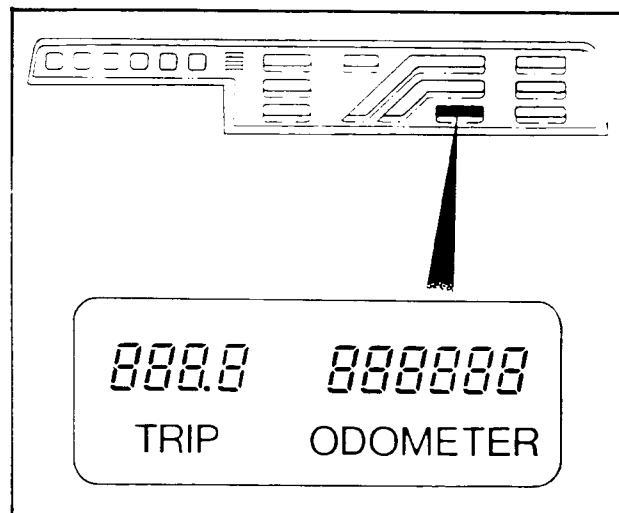

Figure 12C-9

INSTRUMENTS, GAUGES, W'SHIELD WIPERS/WASHERS 12C-7

TRIP COMPUTER

The trip computer is situated to the left of the speedometer.

It comprises three separate displays for time, distance and fuel functions. Refer Fig. 12C-10.

For additional information refer to 1.4 in this Section.

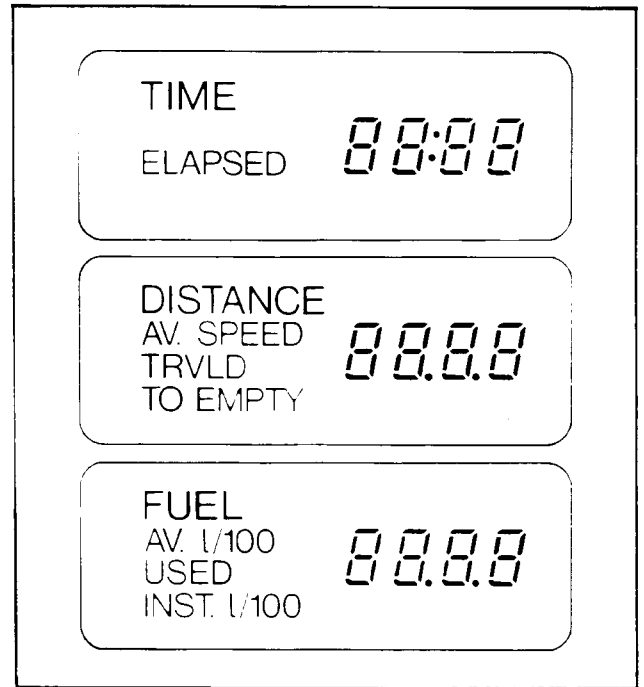

Figure 12C-10

AUTOMATIC INSTRUMENT DISPLAY DIMMING

The intensity of the instrument display is automatically varied to account for surrounding daylight conditions, by a photo transistor situated in the right hand side of the warning lamp panel (Fig. 12C-11).

The photo transistor, upon sensing a change in surrounding daylight conditions, will change the display intensity at one second time intervals.

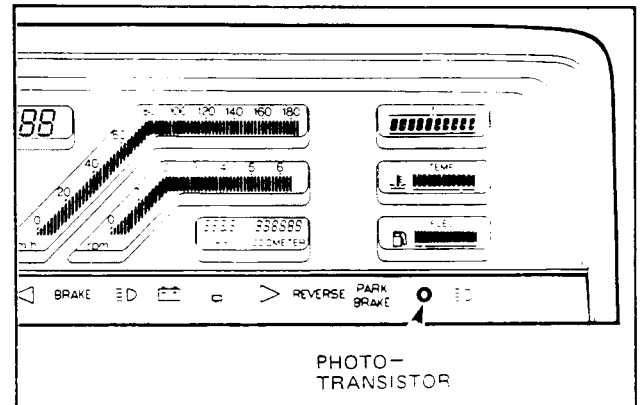

Figure 12C-11

When the headlights are turned on, the display intensity will, if the ambient light is below a daylight threshold level (equivalent to dusk), immediately drop to the intensity level set by the rheostat (Fig. 12C-12). The intensity can then be manually controlled by the rheostat during darkness.

The rheostat is located next to the headlight switch. If ambient light is above this daylight threshold, display intensity will be varied automatically via the photo transistor. This permits full display intensity in daylight even with headlights on. To prevent flickering, a time delay is incorporated. For example, if entering a tunnel or a very shaded area with headlights on and if display intensity is on a daylight setting, the display will not dim to rheostat control till 5 seconds after the ambient light has fallen below the daylight threshold. Display intensity control will not revert to automatic until the ambient light level is significantly higher than the daylight threshold or the headlights are turned off.

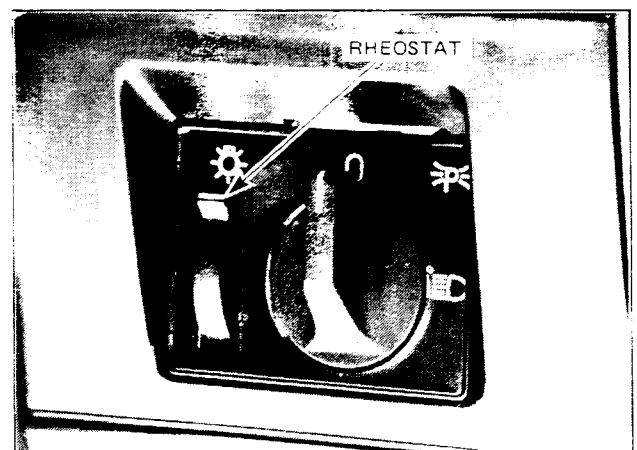

Figure 12C-12

12C-8 INSTRUMENTS, GAUGES, W'SHIELD WIPERS/WASHERS

1.3 TOUCH SWITCHES - MECHANICAL & ELECTRONIC INSTRUMENT ASSEMBLIES

The touch switch control panel is located to the left of the instrument cluster, above the centre dash vents. Refer Fig. 12C-13.

These switches are activated by pressing the small raised finger pad in line with the symbol representing the function to be operated.

Switches are provided for rear window defrost, power antenna up and down, and on station wagon models rear window wipe and wash.

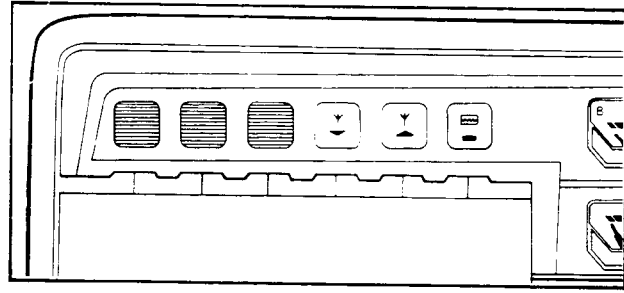

Figure 12C-13

1.4 TRIP COMPUTER

GENERAL DESCRIPTION

The trip computer fitted to Calais models (Fig. 12C-14) is part of the electronic instrument assembly, and has three separate displays to display trip information.

The trip computer is located to the left of the speedometer.

Fuel flow measurement is supplied by the injector signal from the electronic control unit for vehicles equipped with the 3.3 litre EFI engine, or from a Fuel Flow Sensor for vehicles equipped with a 5.0 litre engine.

An electronic speed sensor is mounted on the cruise control transducer.

The eight different pieces of information available from the trip computer are shown below:

TIME	(1) Time (2) Elapsed
DISTANCE	(1) Average speed (km/hr) (2) Travelled (kilometres) (3) To empty (kilometres)
FUEL	(1) Average (litres/100 km) (2) Used (litres) (3) Instantaneous (litres/100 km)

The trip computer displays three functions simultaneously, one from each display of 'TIME', 'DISTANCE' and 'FUEL', and are called up in sequence by depressing the select button.

Each time the select button is pressed, the function in each display will increment by one.

'TIME' and 'ELAPSED TIME' alternate with other functions, giving a variable combination of time with other functions.

The trip computer control buttons are located below the displays (Fig. 12C-15) and are:

1. DISPLAY - (Displays time with ignition off)
2. SELECT - (Increments functions displayed)
3. HOURS - (Adjusts hours when pressed with display button)
4. MINUTES - (Adjusts minutes when pressed with display button)
5. RESET - (Resets computer when pressed with select button)

To avoid accidental reset, time adjustment or calibration, a combination of two buttons must be pressed simultaneously to perform these operations.

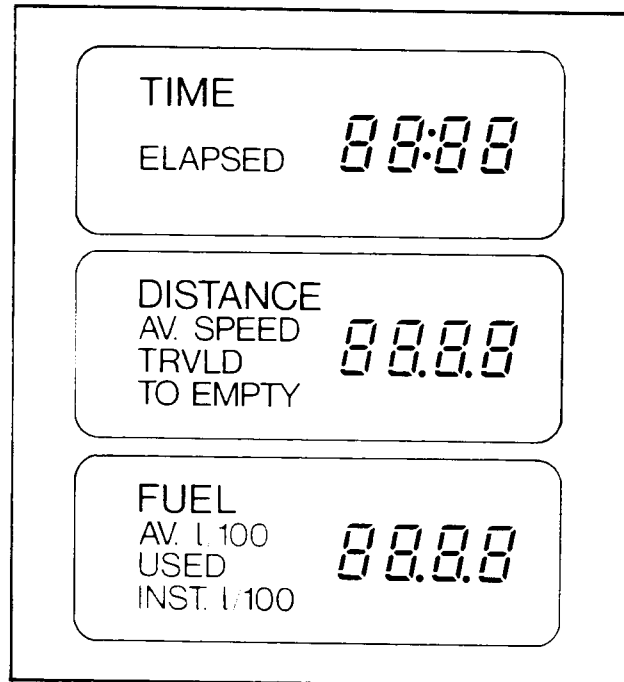

Figure 12C-14

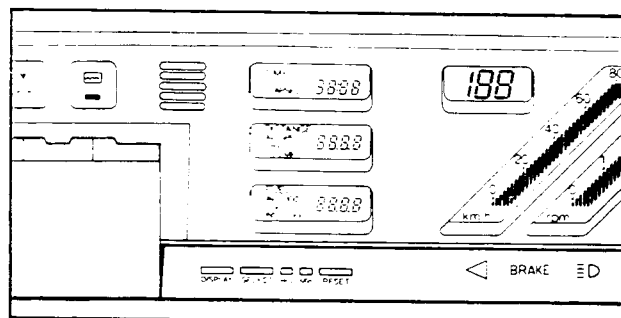

Figure 12C-15

INSTRUMENTS, GAUGES, W'SHIELD WIPERS/WASHERS 12C-9

FUNCTION DESCRIPTION

Time

The clock is a 12 hour clock with flashing decimal point.

When the battery is first connected, the clock will show 12.00 and if this is not the correct time, the appropriate setting is achieved by pressing the 'DISPLAY' and 'MIN' buttons together for minute adjustment and the 'DISPLAY' and 'HOURS' buttons for hour adjustment.

It is recommended that the minutes be adjusted prior to the hours because as the minutes pass 60, the hours will automatically increment by one.

The clock can be accurately set as the next minute will not display until 60 seconds after releasing the adjustment button.

Elapsed Time

Indicates accumulated 'IGNITION ON' time since resetting in hours and minutes up to 99 hours and 59 minutes.

Distance To Empty (DTE)

The distance to empty function is an estimate on how much further the vehicle can be driven on the fuel remaining in the tank, based on the rate of fuel usage for the previous 15 minutes.

The DTE readout adjusts in 5 km increments for values in excess of 50 km and single kilometre increments below this value. No computer can predict the future, so the DTE function can only be an estimate based on previously obtained information. For this reason, as conditions become more suited for economical driving, the distance to empty can actually increase, for example, from City to Highway driving.

After initial battery connection DTE will start at 500. The computer will then perform an initial update from a short average prior to commencing the normal long averaging process.

A built-in safety feature allows up to approximately 30 km of driving under highway conditions after DTE shows zero. However, due to tolerance variations on the components from which the computer derives its information, this figure will vary from vehicle to vehicle.

The computer has electronic damping to flatten out fluctuations of fuel level in the tank and rate of fuel usage and will update the readout after consumption of 0.32 litres of fuel approximately.

Due to the large fuel level fluctuations whilst mobile, the readings are heavily damped and averaged over a long time - up to half an hour. This does not matter during normal operations, but after fuel fill a long delay to display a sensible DTE is not acceptable. So with a fill of 10 litres or more the computer will calculate a higher DTE from a short average at the next normal update and the long averaging will proceed from the new figure.

Distance Travelled/Calibrate

This function reads distance travelled in kilometers since the computer was reset, showing two decimal points up to 100 and whole numbers thereafter.

The calibrate function is designed to allow a very accurate distance calculation and is entered as follows:

1. Select distance travelled mode.
2. Line up the vehicle against a known marker, e.g. centre pillar against a major highway shield.

3. Press reset and hours buttons simultaneously and display will go to zero. Drive off and the display will increase in whole numbers up to a number between 615 and 650, whilst travelling a distance of 10 km. This is the calibration number. Stop vehicle exactly 10 km from starting point, e.g. centre pillar against a major highway shield 10 km from original shield. Press reset and minutes buttons simultaneously. When these buttons are released the calibration number will enter the computer memory and the display will return to travelled mode, and shows the total distance travelled since reset. This calibration does not reset other functions back to zero.

The calibration number should be between 615 and 650 for standard vehicles, however, special tyres, transmission, axle, tyre pressures, vehicle loading, etc. will have a bearing on this number.

Depressing the reset and minute buttons simultaneously any time the distance travelled/calibrate function is called up, will display the calibration number.

For those who do not wish to have this degree of accuracy (1 metre in 10 km) or who do not have access to an accurately measured 10 km, an approximate number of 625 is used for distance calculations.

When the battery is first connected, calibration numbers will automatically be 625. If required calibration number is known, select travelled/calibrated mode, press reset and hours buttons simultaneously, drive vehicle approximately 10 km until required calibration number is reached then press reset and minutes buttons simultaneously. Alternatively recalibrate as described earlier.

Whilst in the calibrate mode, i.e. after the reset and hours buttons are pressed and prior to depression of the reset and minute buttons, the 'SELECT' button is inactivated to prevent selection of other functions during the calibration procedure because this would affect the calibration number and computer distance functions would be inaccurate.

Average Speed

The average speed reading displays average speed since the computer was reset. The average speed is calculated by dividing distance travelled by the time that the ignition has been on.

To enable the computer to collect enough data to calculate a sensible speed, the display will show zero for the first minute after reset.

Reading is updated at one minute intervals.

Instantaneous Consumption

The instantaneous fuel consumption function reads in litres/100 km in whole numbers only and updates at half second intervals.

When the vehicle is stationary, the display shows zero, however, when slowing down to a stop, due to fuel being used and a small distance being travelled, some large numbers may be displayed. Also, when the function is first called up, some large numbers may appear, due to the small time frame over which the computer is prepared.

Average Consumption

The average fuel consumption reads in litres/100 km and calculates fuel usage since last reset and updates at approximately one minute intervals.

12C-10 INSTRUMENTS, GAUGES, W'SHIELD WIPERS/WASHERS

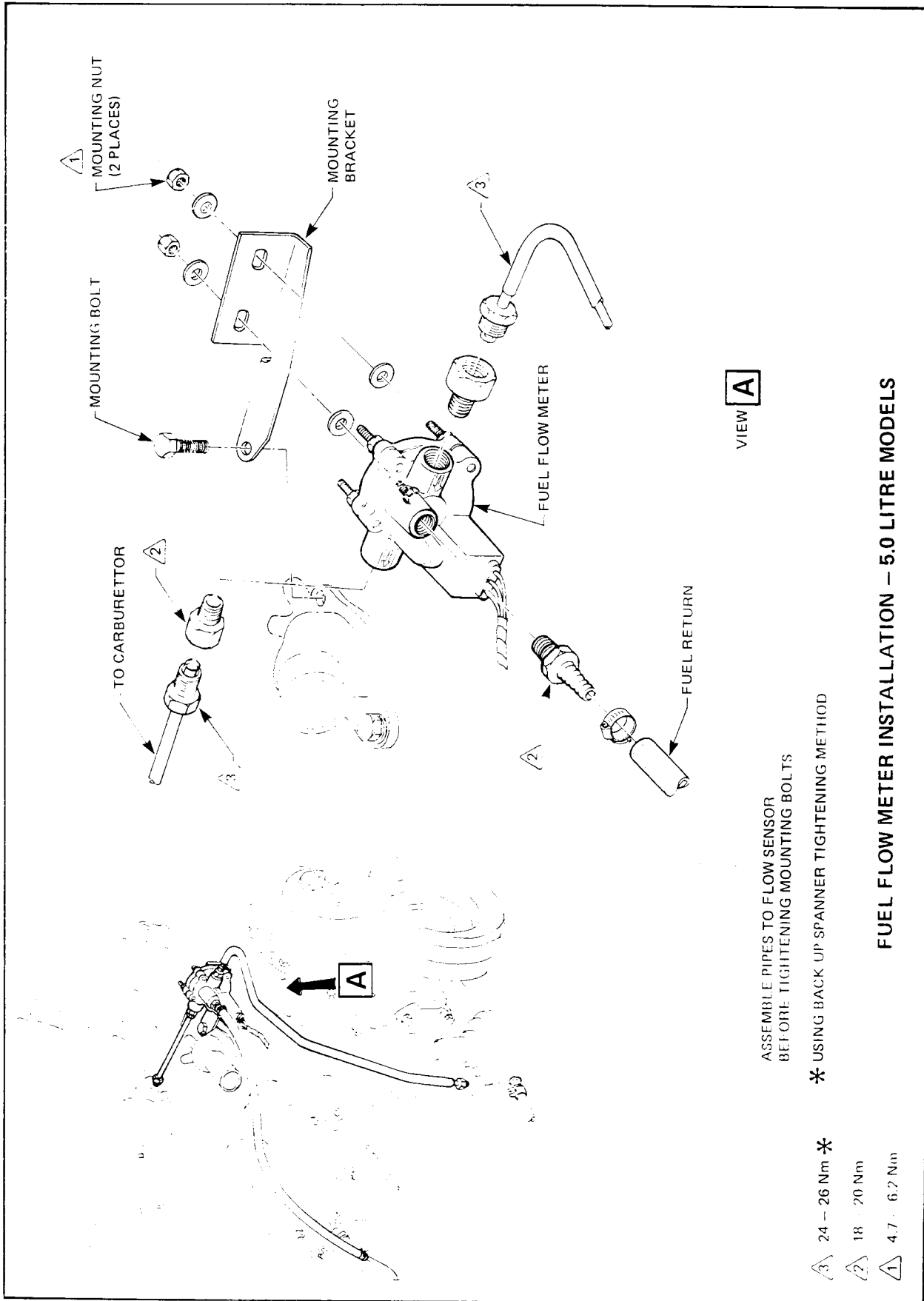

Figure 12C-16

INSTRUMENTS, GAUGES, W'SHIELD WIPERS/WASHERS 12C-11

Fuel Used

Total fuel used since reset is measured in litres to a maximum of 999 litres.

The 'Fuel Left in Tank' is not normally displayed, but a number can be displayed in the DTE mode if the RESET and HRS or MINUTE buttons are depressed simultaneously. This number is equivalent to the amount of fuel, in litres, remaining in the fuel tank that the computer is using to obtain its calculations for the DTE display.

1.5 TRIP COMPUTER COMPONENTS

FUEL FLOW SENSOR

With the 5.0 litre engine, the fuel flow sensor is the same as used on VH Series models. Refer Figs. 12C-16, 12C-17, for installation details.

On fuel injection equipped models, the fuel flow signal is provided by the EFI control unit. The control unit controls the pulse width signal to the injectors, and this signal is also transmitted to the trip computer control module and used as a measure of fuel usage.

FUEL LEVEL SENSOR

The 'fuel to empty' is sensed by the fuel gauge tank unit resistance reading. The tank unit may be checked in the normal manner (refer Fuel Gauge Sender Diagnosis - 2.6 in this Supplement) should any query arise as to readout on display module and actual fuel gauge reading.

ELECTRONIC CONTROL MODULE

The electronic control module is integrated with the display and function module on electronic instrument assemblies.

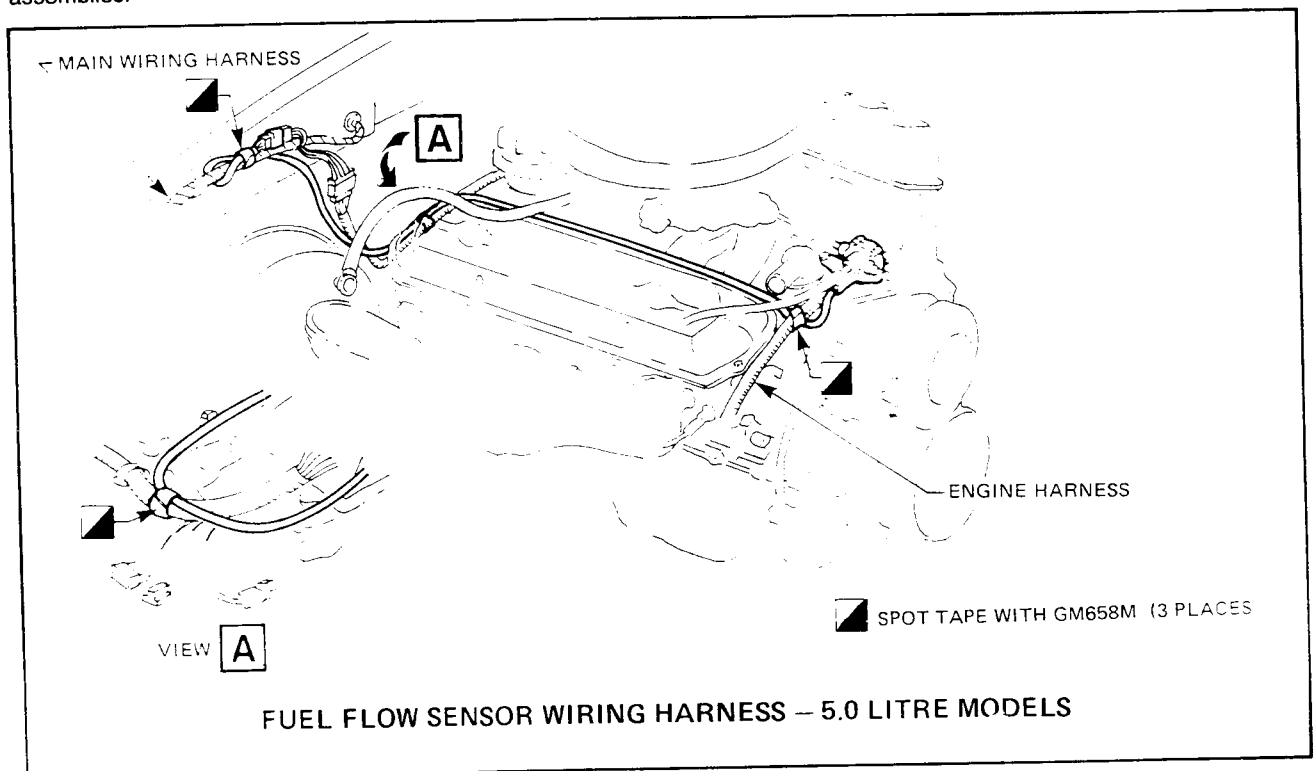

Figure 12C-17

12C-12 INSTRUMENTS, GAUGES, W'SHIELD WIPERS/WASHERS

SPEED SENDER (For Electronic Instruments)

A Hall Effect Speed Sender is used to produce an electrical signal which is proportional to the vehicle's road speed. This signal is used for the electronic instrument readouts of speed and odometer.

This signal is also used by the trip computer and is required for readings of distance to empty, average speed, distance travelled and instantaneous and average fuel consumption.

The sender consists of a metal body which houses a rotating 16 pole magnet. Fitted into the metal body is a plastic cap which contains the electrical terminals and the Hall effect integrated circuit.

The speed sender is mounted on the cruise control transducer. Refer Fig. 12C-18.

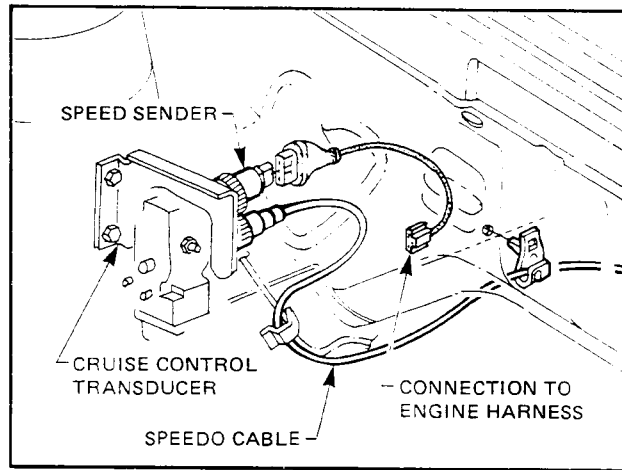

Figure 12C-18

Theory Of Operation

The Hall effect principle is shown in Fig. 12C-19.

A constant control current is passed through a thin strip of semi-conductor material. When a magnet is brought near, such that its magnetic field is directed at right angles to the face of the semi-conductor, a small voltage appears at the contacts placed across the narrow dimension of the strip.

The hall effect voltage is dependent on the presence of the magnetic field and on the current flowing in the semi-conductor. If either input is zero, Hall voltage is zero.

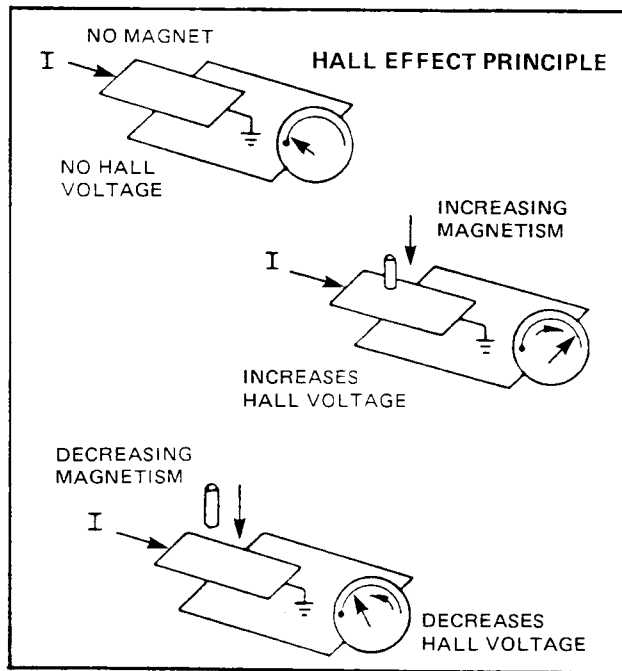

Figure 12C-19

2. SERVICE OPERATIONS

For service operations not covered in this Section, refer to the VB Commodore Service Manual Part No. M38145

and VH Commodore Service Manual Supplement Part No. M38731.

2.1 TOUCH SWITCH CONTROL PANEL REMOVE

1. Carefully lift up front edge of touch switch control panel so as to disengage it from the centre dash vent housing. Refer Fig. 12C-20.



Figure 12C-20

2. Raise the rear of the touch switch control panel and pull panel out slightly to gain access to the wiring harness connector underneath the panel. Refer Fig. 12C-21.
3. Disconnect wiring harness connector and withdraw switch.

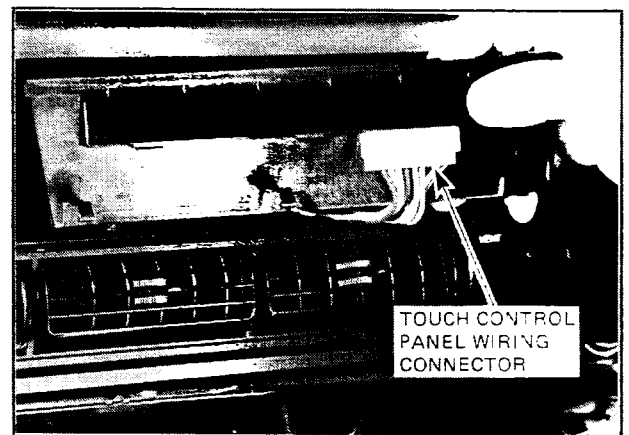

Figure 12C-21

TEST

Using an ohmmeter, test for continuity across terminals when the touch button is pressed. Fig. 12C-22.

Refer to Section 12F 'Wiring Diagrams' of this Supplement for touch switch control panel wiring.

REINSTALL

Installation is reverse of removal procedures ensuring wiring harness connector is securely connected.

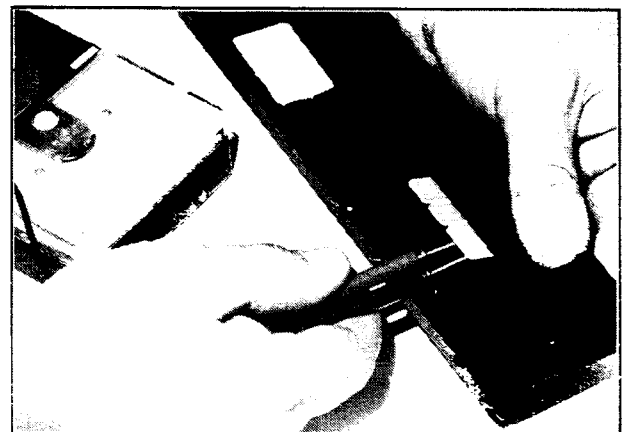

Figure 12C-22

12C-14 INSTRUMENTS, GAUGES, W'SHIELD WIPERS/WASHERS

2.2 INSTRUMENT CLUSTER - MECHANICAL INSTRUMENTS

REMOVE

1. Disconnect battery earth lead.
2. Remove touch switch control panel as per service operation 2.1.
3. Remove the screws securing the instrument frame to the instrument surround. Refer Fig. 12C-23.
4. Pull the instrument frame out, far enough to gain access to the warning lamp panel wiring connectors. Refer Fig. 12C-23.
5. Disconnect wiring connectors and withdraw instrument frame.
6. Remove the right hand instrument panel lower trim.
7. Reach up behind the instrument cluster and disconnect the vacuum hose from the fuel consumption meter (SL models), and the speedometer cable by depressing the spring retainer.

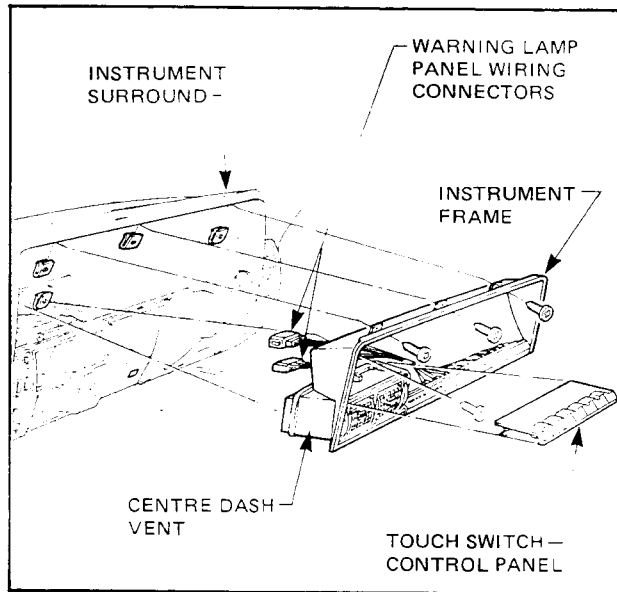

Figure 12C-23

8. Remove the five screws securing the instrument cluster to the instrument surround. Refer Fig. 12C-24.
9. Pull the cluster from its location and rotate the bottom of the cluster upwards to gain access to the wiring connectors.
10. Disconnect wiring connectors and withdraw instrument cluster.

REINSTALL

Installation is reversal of removal procedures. Ensure that all electrical connectors are securely connected.

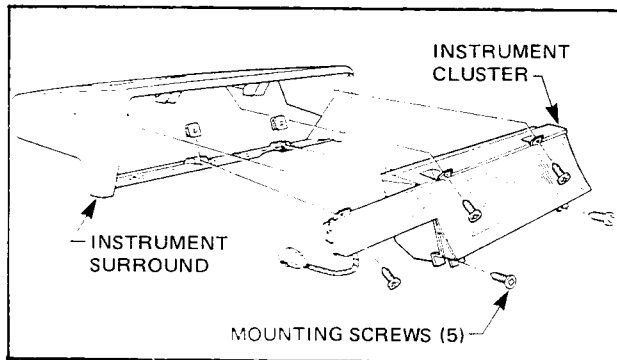

Figure 12C-24

2.3 INSTRUMENT CLUSTER - ELECTRONIC INSTRUMENTS

REMOVE

1. Disconnect battery earth lead.
2. Remove touch switch control panel as per service operation 2.1.
3. Remove the screws securing the instrument frame to the instrument surround. Refer Fig. 12C-25.
4. Pull the instrument frame out, far enough to gain access to the warning lamp panel wiring connectors. Refer Fig. 12C-25.
5. Disconnect wiring connectors and withdraw instrument frame.

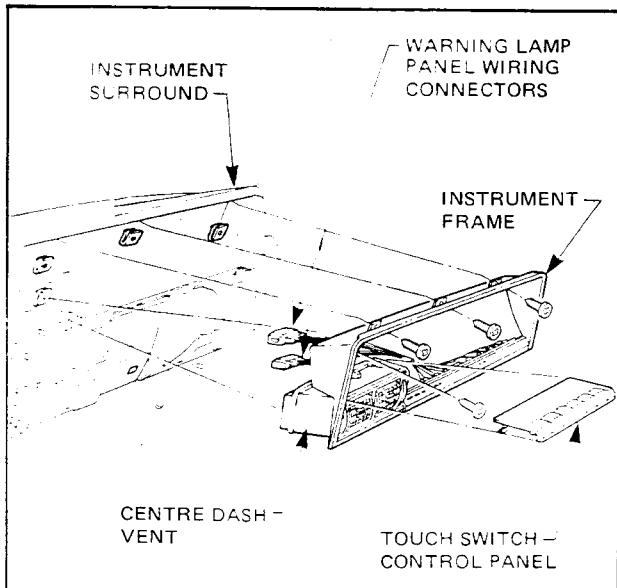

Figure 12C-25

INSTRUMENTS, GAUGES, W'SHIELD WIPERS/WASHERS 12C-15

6. Remove the five screws securing the instrument cluster to the instrument surround. Refer Fig. 12C-26.
7. Pull the cluster from its location and rotate the bottom of the cluster upwards to gain access to the wiring connectors.
8. Disconnect wiring connectors, and withdraw instrument cluster.

REINSTALL

Installation is reversal of removal procedures. Ensure that all electrical connectors are securely connected.

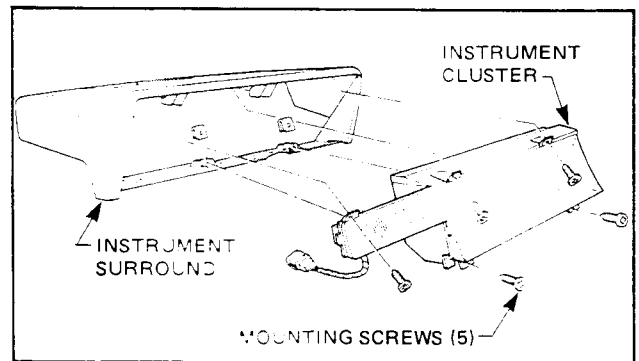

Figure 12C-26

2.4 MECHANICAL INSTRUMENTS

DISASSEMBLY

Pull adjusting knob from clock. Remove the six screws (1) retaining the clear facia panel to the instrument housing, remove facia. Remove the three screws (2) retaining the black instrument surround to the instrument housing, remove surround. (Refer Fig. 12C-27).

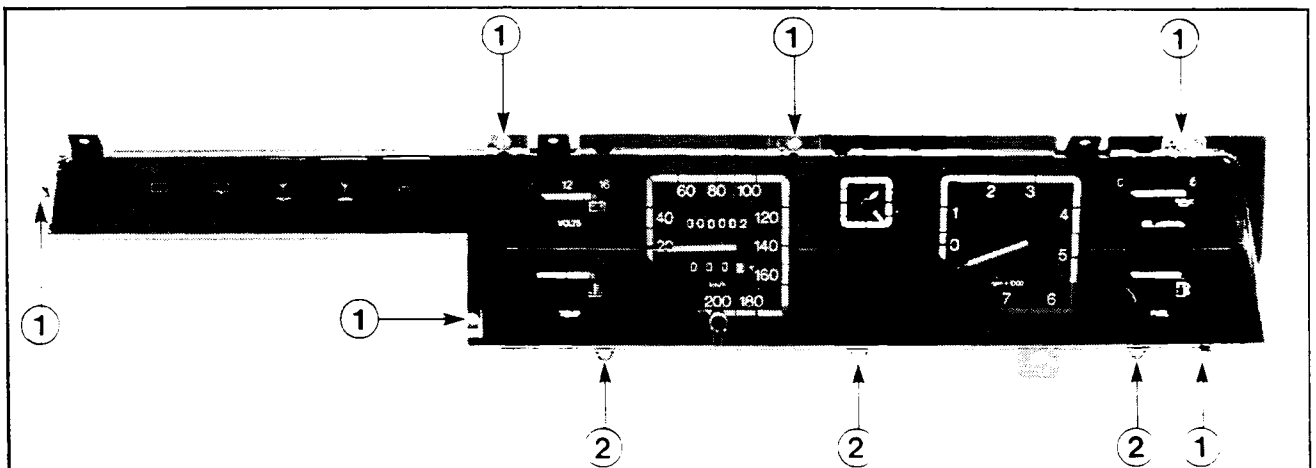

Figure 12C-27

Speedometer, Fuel Consumption Indicator and Tachometer

Remove retaining screws and withdraw unit (Refer Fig. 12C-28). When removing tachometer, carefully withdraw contacts from printed circuit.

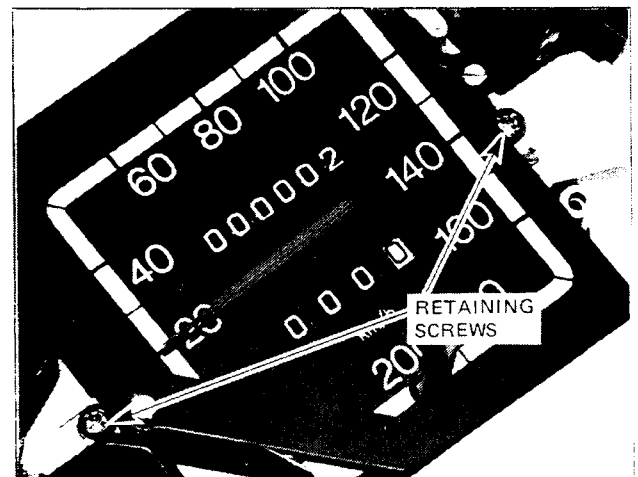

Figure 12C-28

12C-16 INSTRUMENTS, GAUGES, W'SHIELD WIPERS/WASHERS

Fuel and Temperature Gauges

Remove gauge retaining screw (Fig. 12C-29). Compress plastic retaining tang and withdraw gauge contacts from printed circuit. (Fig. 12C-29).

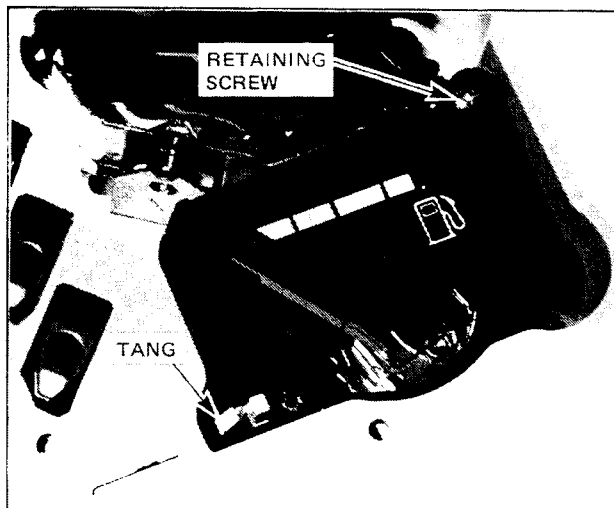

Figure 12C-29

Voltmeter and Oil Pressure Gauge

1. Remove overlapping fuel or temperature gauge as previously described.
2. Remove remaining screw and withdraw gauge contacts from printed circuit (Fig. 12C-30).

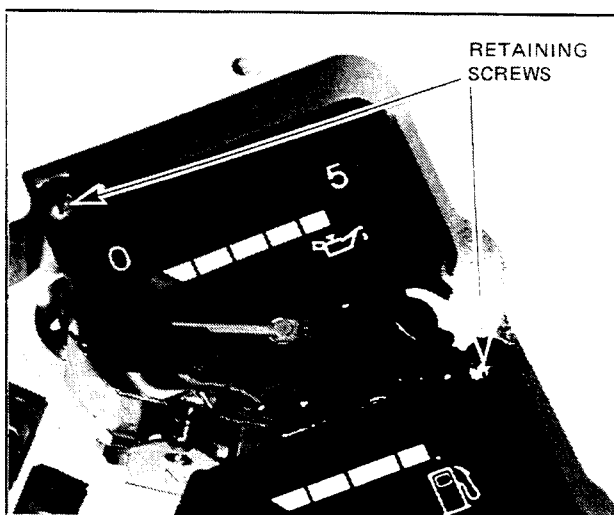

Figure 12C-30

Clock

From behind the instrument housing, remove connector from printed circuit. Remove the two screws retaining the clock assembly to the instrument housing and remove clock. (Fig. 12C-31).

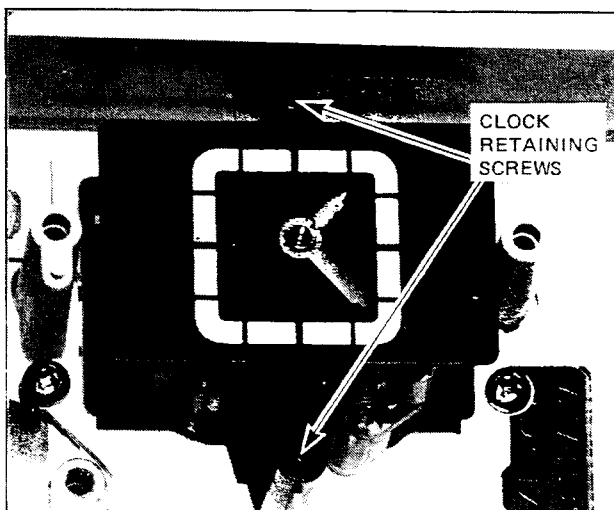

Figure 12C-31

INSTRUMENTS, GAUGES, W'SHIELD WIPERS/WASHERS 12C-17

Printed Circuit Board

1. Compress and withdraw retaining clip/heat sink and voltage stabilizer assembly from housing. (Fig. 12C-32).
2. Slide printed circuit board to the right as viewed in Fig. 12C-32 and lift out.

REASSEMBLY

1. Reverse removal operations.
2. Install retaining clip/heat sink ensuring voltage stabilizer contacts locate properly.
3. Install upper gauges first, ensuring gauge contacts are properly seated.

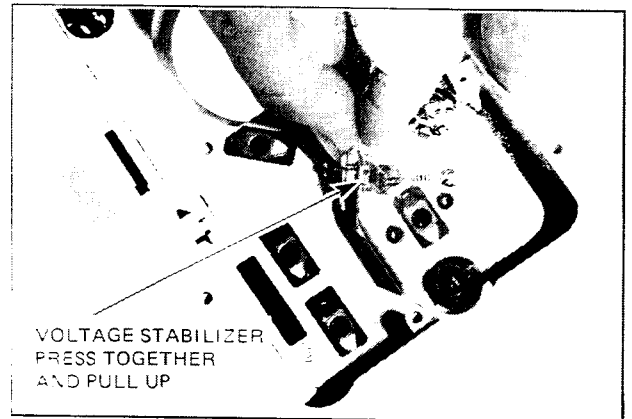

Figure 12C-32

2.5 INSTRUMENT TESTING

For mechanical instrument testing refer to Section 12 of the VB Commodore Service Manual Part No. M38145.

Should a fault develop in the electronic instrument assembly, it must be returned to an authorized VDO service agent for repair.

In the event that the electronic instrument assembly proves faulty, the odometer reading must be noted before the unit is removed to allow the VDO agent to transfer the odometer reading to the replacement instrument assembly. The VDO agent also has equipment to read the odometer from the instruments computer memory if a display blackout occurs.

SPEED SENDER

Remove

1. Disconnect battery earth lead.
2. Disconnect sender wiring connector. Refer Fig. 12C-33.
3. Unscrew sender from cruise control transducer remove sender.

Test

1. Connect 4.7 ohm 1/4 watt resistor across terminals marked + and A.
2. Connect 12 volt DC battery supply to terminals marked + and - (observe polarity).
3. Connect pointer type multimeter set on DC volts scale to terminals + and A (observe polarity, positive terminal of multimeter to terminal - , negative terminal of multimeter to terminal A).
4. Rotate sender square drive slowly by hand and observe multimeter reading which should pulse between 12 volts and 0 volts.
5. No pulse reading on multimeter indicates faulty sender.

NOTE: Sender is non repairable.

Reinstall

Installation is reversal of removal.

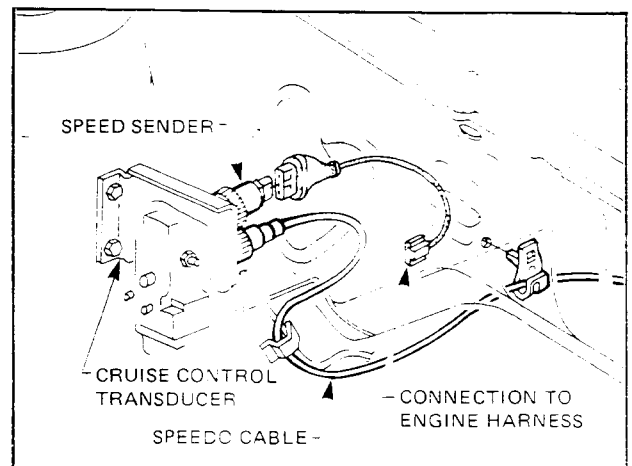

Figure 12C-33

12C-18 INSTRUMENTS, GAUGES, W'SHIELD WIPERS/WASHERS

2.6 FUEL GAUGE SENDER UNIT

REMOVE

The removal and installation instructions for vehicles with 5.0 litre engine with the revised fuel pump system and 3.3 litre EST engine, are covered in Section 8 of the VB Commodore Service Manual.

The following removal and installation procedures are for 3.3 litre EFI equipped vehicles.

1. Disconnect battery earth lead.
2. Place the vehicle on jack stands and drain the tank through fuel filler opening using a commercially available fuel syphoning device.
3. Disconnect the fuel line from gauge unit.
4. Disconnect the electrical feed and earth cables from unit. Refer Fig. 12C-34.
5. Remove 5 mounting screws around gauge unit.
6. Remove gauge unit, lifting gauge unit filter from swirl pot.

CAUTION: Care should be exercised during removal of gauge unit from the tank not to damage the filter. Before installing the assembly into fuel tank, clean the screen by blowing off carefully with low pressure dried compressed air; replace screw if damaged or unable to clean.

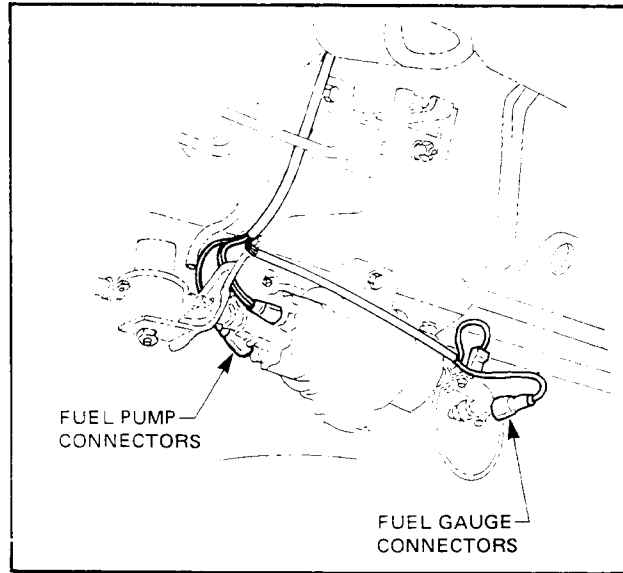

Figure 12C-34

FUEL GAUGE SENDER UNIT DIAGNOSIS

1. Turn ignition to 'ON' and observe the fuel gauge for one minute. The gauge reading will do one of three things.
 - a. Gauge reads below empty - Fuel tank empty of gauge sender is open circuited.
 - b. Gauge reads between empty and full, but is suspected to be inaccurate. Proceed to step 2.
 - c. Gauge reads above full - Fuel tank is full or gauge sender is short circuited.
2. Using a voltmeter, check for a voltage reading at the fuel gauge sender unit flange to earth (ignition switched 'ON'). If recording a voltage reading, correct faulty earth at fuel tank or add an earth wire.
3. Remove the wire terminal connector (fuel gauge to sender unit) from sender unit and check voltage at the terminal connector to earth with an accurate high resistance voltmeter (ignition switched 'ON').

If the voltage recorded at the terminal connector is 10 0.1 volts, then the voltage regulator on the instrument printed circuit board is OK.

If the reading is outside the specification of 10 0.1 volts, check for poor connections at the printed circuit board and voltage regulator.

If the connectors are OK, replace voltage regulator, refer to service operation 2.4 Mechanical Instrument Disassembly, in this Section.

If the reading is within the specification of 10 0.1 volts, remove the fuel gauge sender unit, refer to service operation 2.6 Fuel Gauge Sender Unit - Remove, in this Section.

Check the sender unit for binding or sticking.

Connect an ohmmeter to fuel gauge terminal on sender unit and to the sender unit flange.

Set the float to the various height dimensions, as shown in the following chart, and record the resistance at each dimension.

INSTRUMENTS, GAUGES, W'SHIELD WIPERS/WASHERS 12C-19

Model		Resistance (ohms)	Height (mm)
3.3 litre EST – Sedan	Empty	283 ± 7 @	0
	½	97 ± 14 @	75
	Full	35 – 40 @	top
3.3 litre EST – Wagon	Empty	283 ± 7 @	0
	½	100 ± 14 @	66.5
	Full	35 – 40 @	top
3.3 litre EFI – Sedan 5.0 litre – Sedan	Empty	283 ± 7 @	0
	¼	145.5 ± 4 @	35.25
	½	97.3 ± 3 @	69.5
	¾	66.5 ± 2.5 @	103.25
	Full	40 ± 2 @	140.8
Upper Stop	Under 35 @	147	
5.0 litre – Wagon	Empty	283 ± 7 @	0
	¼	145.5 ± 4 @	36
	½	97.3 ± 3 @	67
	¾	66.5 ± 2.5 @	100
	Full	40 ± 2 @	172
Upper Stop	35 @	189.4	

REINSTALL

Reverse to removal operations noting the following:

1. Install seal between the gauge unit flange and tank.
2. Apply sealing compound part no. M39040 to mating surfaces of cork seal and fuel tank, also to screw threads.
3. Fill fuel tank with fuel and check for leaks around gauge unit.

FUEL TANK

Fuel tank removal and installation instructions remain the same as on previous models. The only difference with EFI models is on removal, the fuel return line must be disconnected and reconnected on installation. Refer Section 8A in this Supplement for details.

12C-20 INSTRUMENTS, GAUGES, W'SHIELD WIPERS/WASHERS

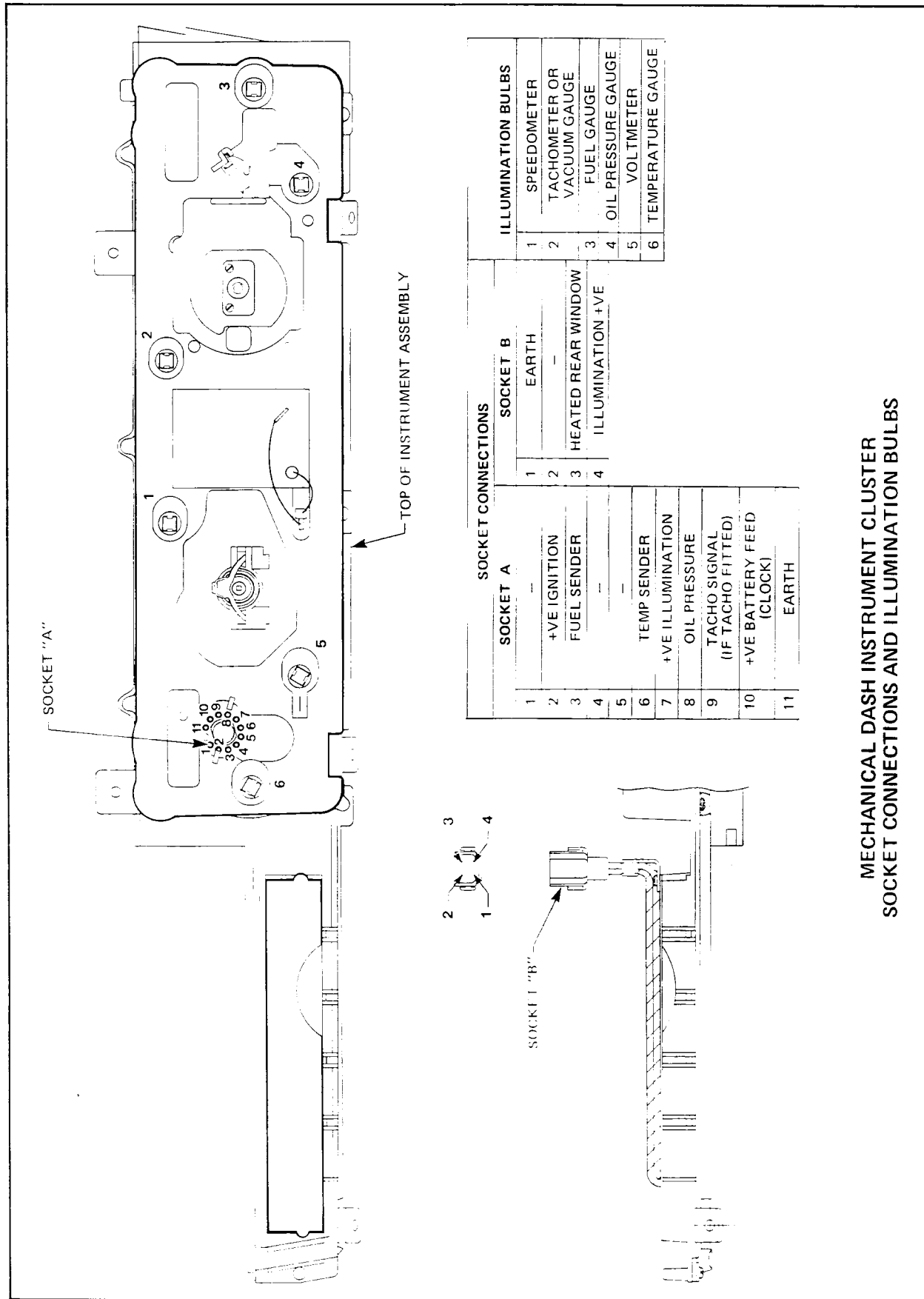

MECHANICAL DASH INSTRUMENT CLUSTER
SOCKET CONNECTIONS AND ILLUMINATION BULBS

Figure 12C-35

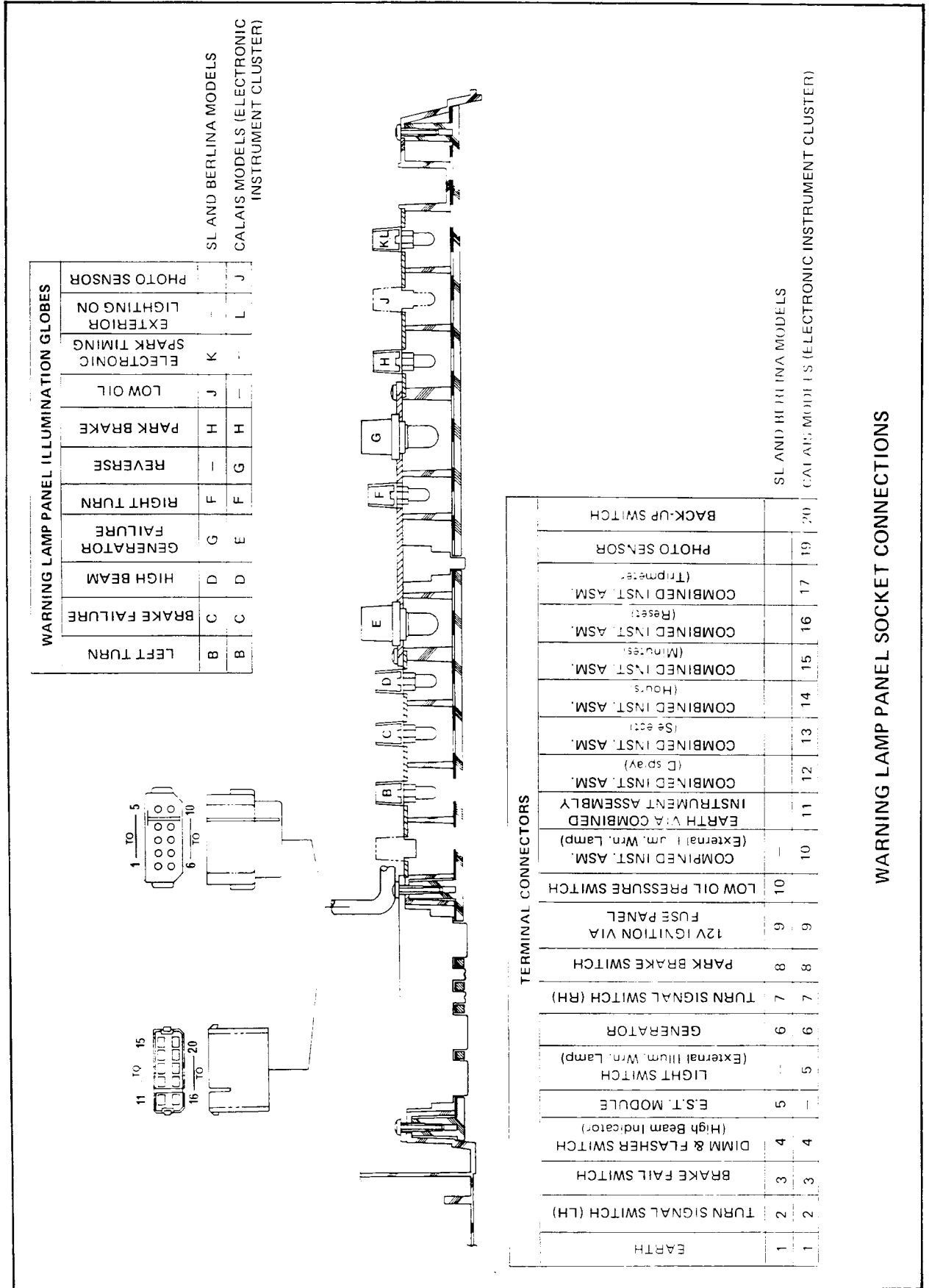

WARNING LAMP PANEL ILLUMINATION GLOBES

LEFT TURN	B	C	D	E	F	G	H	J	K	L	J
BRAKE FAILURE	B	C	D	E	F	G	H	J	K	L	J
HIGH BEAM			D	D	F	F	H	J	K	L	J
GENERATOR FAILURE			G	E	F	F	H	J	K	L	J
RIGHT TURN			F	F	F	G	H	J	K	L	J
REVERSE			-	-	F	G	H	J	K	L	J
PARK BRAKE			-	-	F	G	H	J	K	L	J
LOW OIL			-	-	F	G	H	J	K	L	J
ELECTRONIC SPARK TIMING			-	-	F	G	H	J	K	L	J
EXTERIOR LIGHTING ON			-	-	F	G	H	J	K	L	J
PHOTO SENSOR			-	-	F	G	H	J	K	L	J

SL AND BERLINA MODELS
CALAIS MODELS (ELECTRONIC INSTRUMENT CLUSTER)

TERMINAL CONNECTORS

1	2	3	4	5	6	7	8	9	10	11	12	13	14	15	16	17	19	20			
EARTH	TURN SIGNAL SWITCH (LH)	BRAKE FAIL SWITCH	DIMM & FLASHER SWITCH	(High Beam Indicator)	E.S.T. MODULE	LIGHT SWITCH	(External Illum. Wrn. Lamp)	GENERATOR	TURN SIGNAL SWITCH (RH)	PARK BRAKE SWITCH	12V IGNITION VIA FUSE PANEL	LOW OIL PRESSURE SWITCH	COMBINED INST. ASM. (External Illum. Wrn. Lamp)	COMBINED INST. ASM. (Display)	COMBINED INST. ASM. (Select)	COMBINED INST. ASM. (Hours)	COMBINED INST. ASM. (Minutes)	COMBINED INST. ASM. (Reset)	COMBINED INST. ASM. (Tripmeter)	PHOTO SENSOR	BACK-UP SWITCH

SL AND BERLINA MODELS
CALAIS MODELS (ELECTRONIC INSTRUMENT CLUSTER)

WARNING LAMP PANEL SOCKET CONNECTIONS

12C-22 INSTRUMENTS, GAUGES, W/SHIELD WIPERS/WASHERS

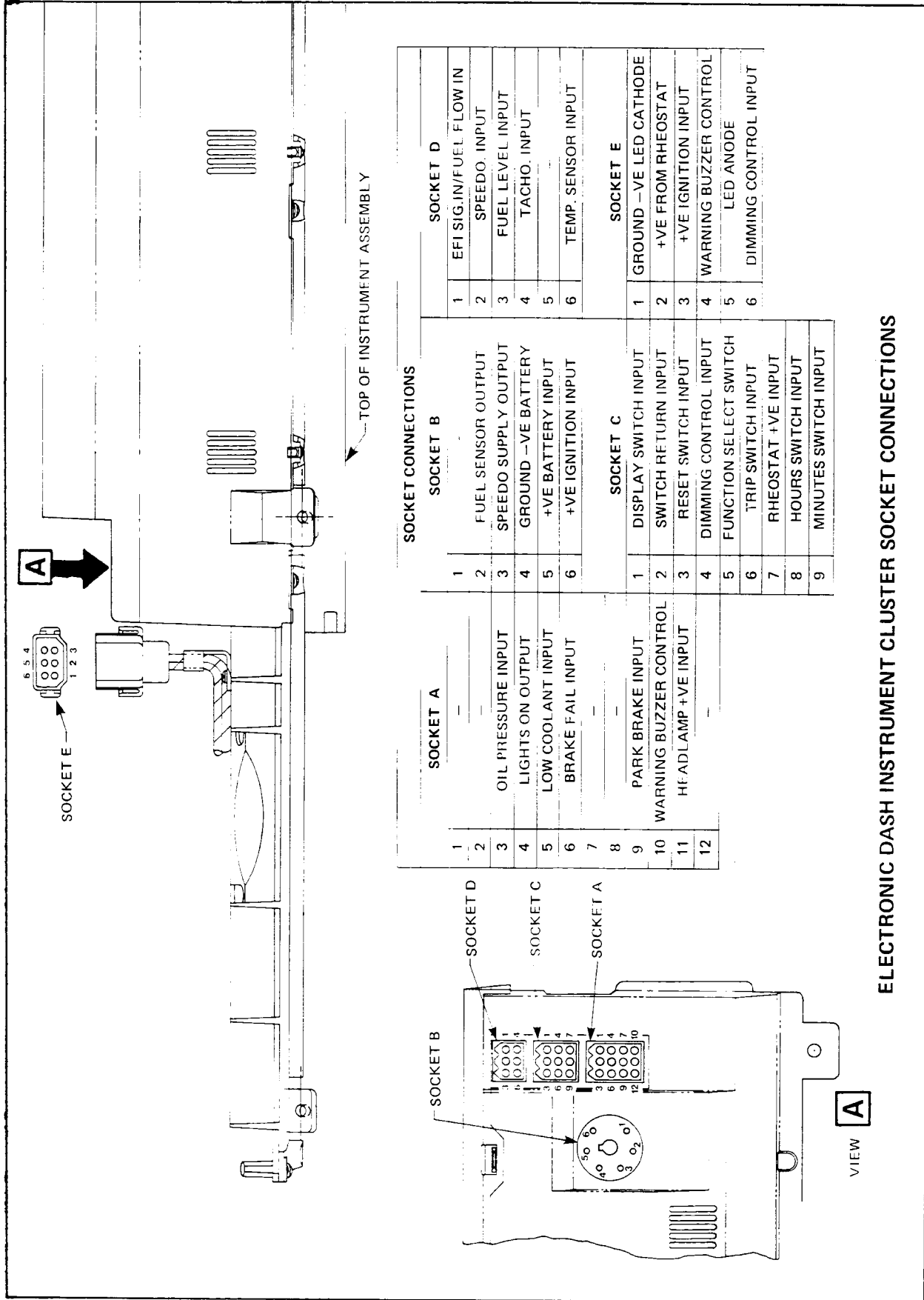

SOCKET CONNECTIONS

SOCKET A		SOCKET B				SOCKET C			SOCKET D			SOCKET E		
1		1	FUEL SENSOR OUTPUT	1	DISPLAY SWITCH INPUT	1	GROUND -VE LED CATHODE	1	EFI SIG.IN/FUEL FLOW IN	1	SPEEDO. INPUT	1	GROUND -VE LED CATHODE	
2		2	SPEEDO SUPPLY OUTPUT	2	SWITCH RETURN INPUT	2	+VE FROM RHEOSTAT	2	SPEEDO. INPUT	2	FUEL LEVEL INPUT	2	+VE FROM RHEOSTAT	
3	OIL PRESSURE INPUT	3	GROUND -VE BATTERY	3	RESET SWITCH INPUT	3	+VE IGNITION INPUT	3	FUEL LEVEL INPUT	3	TACHO. INPUT	3	+VE IGNITION INPUT	
4	LIGHTS ON OUTPUT	4	+VE BATTERY INPUT	4	DIMMING CONTROL INPUT	4	WARNING BUZZER CONTROL	4	TACHO. INPUT	4	TEMP. SENSOR INPUT	4	WARNING BUZZER CONTROL	
5	LOW COOLANT INPUT	5	+VE IGNITION INPUT	5	FUNCTION SELECT SWITCH	5	LED ANODE	5	TEMP. SENSOR INPUT	5		5	LED ANODE	
6	BRAKE FAIL INPUT	6		6	TRIP SWITCH INPUT	6	DIMMING CONTROL INPUT	6		6		6	DIMMING CONTROL INPUT	
7				7	RHEOSTAT +VE INPUT									
8				8	HOURS SWITCH INPUT									
9	PARK BRAKE INPUT			9	MINUTES SWITCH INPUT									
10	WARNING BUZZER CONTROL													
11	HEADLAMP +VE INPUT													
12														

ELECTRONIC DASH INSTRUMENT CLUSTER SOCKET CONNECTIONS

Figure 12C-37

INSTRUMENTS, GAUGES, W'SHIELD WIPERS/WASHERS 12C-23

2.7 SPEEDOMETER GEAR CHART

REAR AXLE		TRANSMISSION		SPEEDO DRIVEN GEAR		TYRE OPTION NUMBERS											
P/O	Ratio	P/O	Speedo Drive Gear Colour	Colour	Number of Teeth	QBC	QCJ	QCH	QCR	QBD	QST	QQY	QFL	QEU	QBY	QQN	
G70	2.60 : 1	M40	10 Teeth Yellow	Dark Blue	22		X	X	X				X				
				Green	21										X		
GU4	3.08 : 1	MC6	7 Teeth Brown	Red	18	X	X	X	X		X		X		X	X	
				Dark Blue	22									X			
		M40	9 Teeth Blue	Red	23	X	X	X	X		X		X		X	X	
				Dark Blue	22									X			
		L6	M76	8 Teeth Pink	White	20		X	X	X		X		X		X	X
					Green	21	X										
V8	M40	10 Teeth Yellow	Light Blue	25		X	X	X					X	X			
GV4	3.36 : 1	M76	8 Teeth Pink	Dark Blue	22	X	X	X	X		X		X		X	X	

KEY TO TYRE OPTION NUMBERS

QBC BR60 H15	QCR CR78 S14	QQY 175SR13
QCJ CR70 H14	QBD BR78 S13	QFL P205 60 HR15
QCH CR78 H14	QST 165SR14	QEU ER70 H14
		QBY BR78 S14
		QQN P175/75 SR14

12C-24 INSTRUMENTS, GAUGES, W'SHIELD WIPERS/WASHERS

3. WINDSHIELD WIPER AND WASHER

3.1 GENERAL DESCRIPTION

The windshield wiper and washer system carries over from VH to VK Series models, except for the location of the dwell control switch.

On models with dwell wiper control, the control switch is now located on the left hand lower dash surround.

The windshield washers 'in line', one way valve has been deleted.

3.2 SERVICE OPERATIONS

Service operations are as described in Section 12, Holden Commodore VB Series Service Manual Part No. M38145, except where noted in this Section.

3.3 WIPER DWELL CONTROL SWITCH

REMOVE

1. Remove instrument assembly surround as per service instruction 2.3, steps 1 - 5, in this Section.
2. Pull knob from switch.
3. Remove the left hand lower dash surround upper and lower screws. Refer Fig. 12C-38.

NOTE: It may be necessary to remove the centre console to gain access to the lower screws.

4. Remove the right hand instrument panel lower cover.

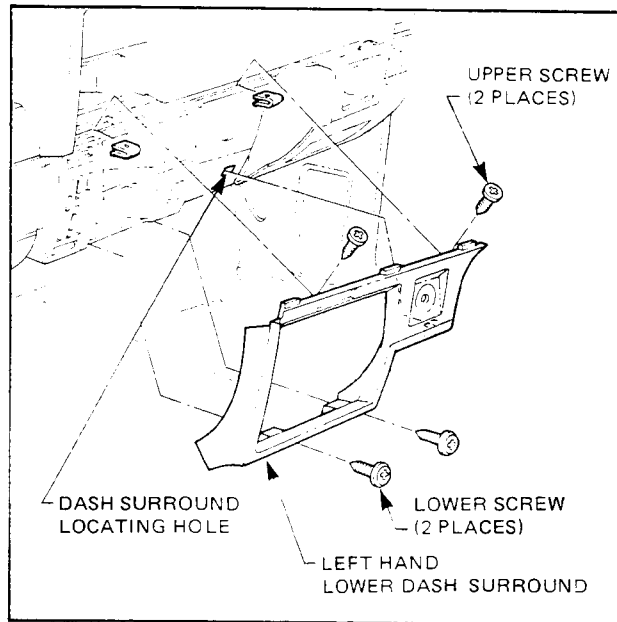

Figure 12C-38

5. Disconnect the wiper dwell control switch wiring connector from the main wiring harness. Refer Fig. 12C-39.
6. Remove lower dash surround and switch.
7. Remove switch mounting nut and separate switch from panel.

REINSTALL

Installation is reversal of removal procedures. Ensure the locating lug on the left hand lower dash surround fits into the locating square. Check operation of switch.

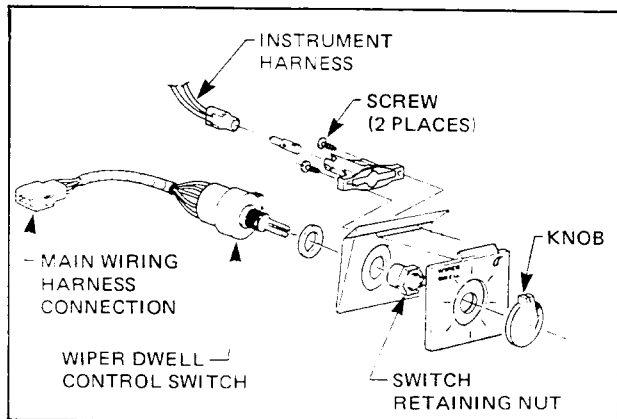

Figure 12C-39

SECTION 12D

RADIO AND TAPE PLAYER

INDEX

Ref.	Subject	Page	Ref.	Subject	Page
1.	GENERAL DESCRIPTION	12D-1	3.	DIAGNOSIS	12D-8
2.	SERVICE OPERATIONS	12D-2	4.	SPECIFICATIONS	12D-9
2.1	RADIO OR RADIO CASSETTE PLAYER		5.	TORQUE WRENCH SPECIFICATIONS	12D-9
	ASSEMBLY	12D-2	6.	SPECIAL TOOLS	12D-9
	Remove	12D-2			
	Reinstall	12D-3			
2.2	SPEAKERS	12D-3			
	Remove	12D-3			
	Reinstall	12D-5			

1. GENERAL DESCRIPTION

All VK Series models are fitted with a radio. SL models are supplied with a high performance AM/FM radio with digital display for channels and frequencies, a 2 way speaker system and a manual, key lock antenna.

Berlina models have an AM/FM stereo radio cassette unit, in lieu of the AM/FM radio. The radio is an AM/FM stereo signal seeking radio with digital display for channels and frequencies. The speaker system is a 2 way speaker system.

Calais models are fitted with a similar radio/cassette unit to the Berlina models. Features of this radio/cassette unit include a single joystick balance control for a 4 way speaker system and automatic programme search for cassettes.

The four speakers are located, two in the rear parcel shelf and one at each upper corner of the instrument dash panel.

The operating instructions for each unit is included in the Owners Handbook.

A power operated antenna is standard on Berlina and Calais models. The antenna is automatically raised to a medium height when the radio is turned on and can be further raised or lowered by means of the antenna control switches on the instrument touch control panel.

12D-2 RADIO AND TAPE PLAYER

2. SERVICE OPERATIONS

2.1 RADIO OR RADIO CASSETTE PLAYER ASSEMBLY

REMOVE

1. Disconnect battery earth lead.
2. Remove touch control panel as per service operation 2.1, Section 12C of this Supplement.
3. Remove instrument surround and instrument assembly as per service operation 2.2 or 2.3, Section 12C of this Supplement.
4. Remove centre console, centre lower instrument panel, glove box, steering column lower surround, heater cover panel and left hand lower dash panel as per service operations described in Section 1A of this supplement.
5. Remove centre air vent duct.
6. Remove radio - radio/cassette player rear bracket screw/s from instrument carrier panel assembly. Refer Fig. 12D-1.
7. Remove heat/vent control assembly with temperature control cable attached, removing vacuum hose and electrical connectors.
8. Remove lower left side instrument panel and radio - radio/cassette player as an assembly.
9. Disconnect electrical connector and antenna from radio - radio/cassette player.
10. Remove the front mounting bracket, screwed into the top of the unit. Refer Fig. 12D-2.
11. Remove rear bracket attaching screw.

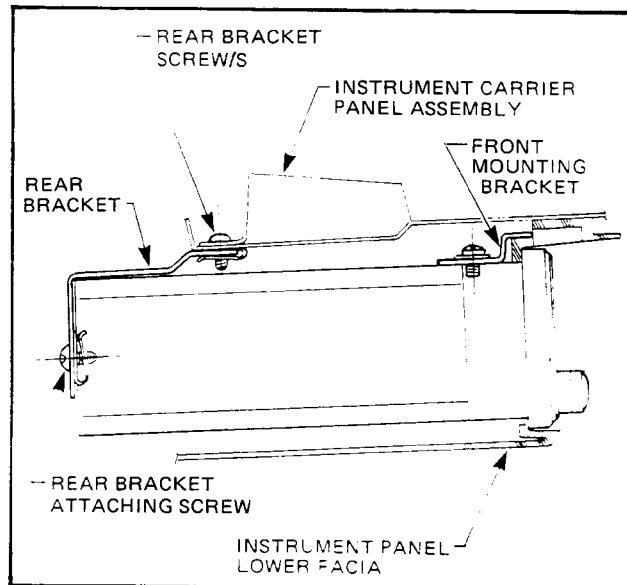

Figure 12D-1

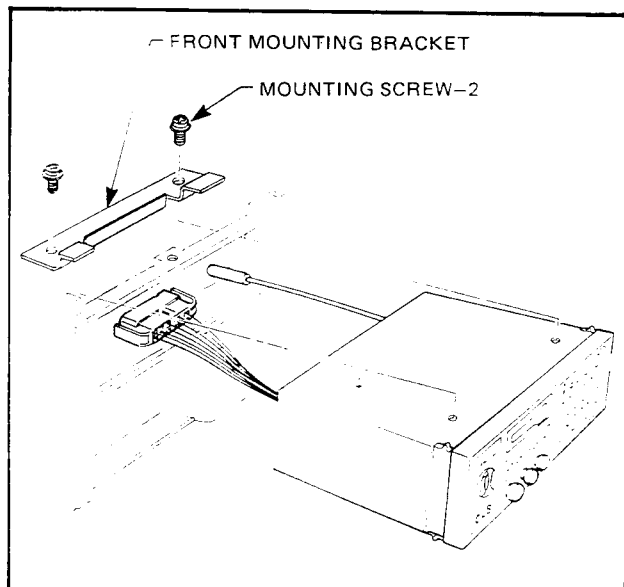

Figure 12D-2

RADIO AND TAPE PLAYER 12D-3

12. Insert removal tools CMT113 simultaneously into slots in right and left hand sides of radio - radio/cassette player facia, refer Fig. 12D-3, to disengage the spring mechanism securing the inner part of the radio facia to the left hand lower dash panel.
13. Remove radio - radio/cassette from dash panel.
14. From behind sides of radio facia, depress spring mechanism, which will release removal tools from radio - radio/cassette player.
15. Removal tools, Part No. CMT113, which are released in pairs, are available direct from -

Eurovox Australia,
6 University Place,
Clayton North. Vic. 3168.

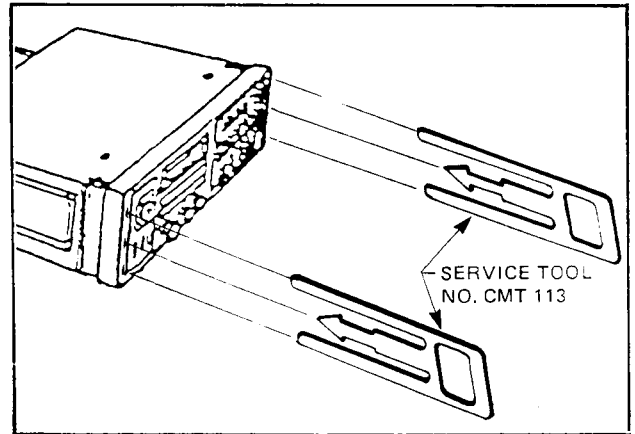

Figure 12D-3

REINSTALL

Insert radio - radio/cassette player in dash aperture until the locking springs click.
The remainder of the installation is the reversal of removal procedures.

2.2 SPEAKERS

REMOVE

Single Speaker - Front

1. Remove speaker grille.
2. Remove speaker securing screws, refer Fig. 12D-4.
3. Lift up speaker to disconnect wiring harness connector. Remove speaker, refer Fig. 12D-4.

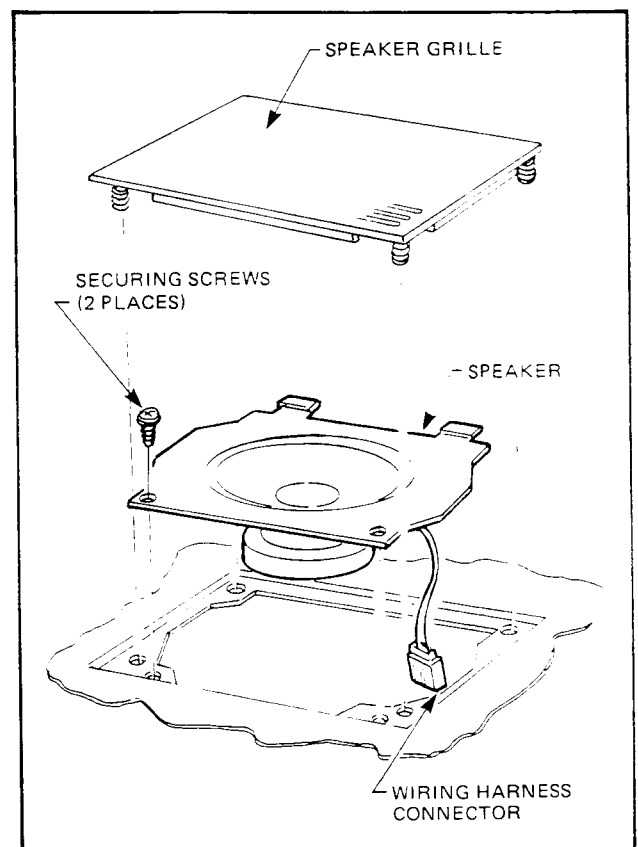

Figure 12D-4

12D-4 RADIO AND TAPE PLAYER

Dual Speakers - Front

1. Using a wide blade screwdriver, insert between grille and instrument pad.
2. Carefully lever speaker grille upwards. Lift speaker from its position, disconnect wiring harness connector and remove speaker, refer Fig. 12D-5.

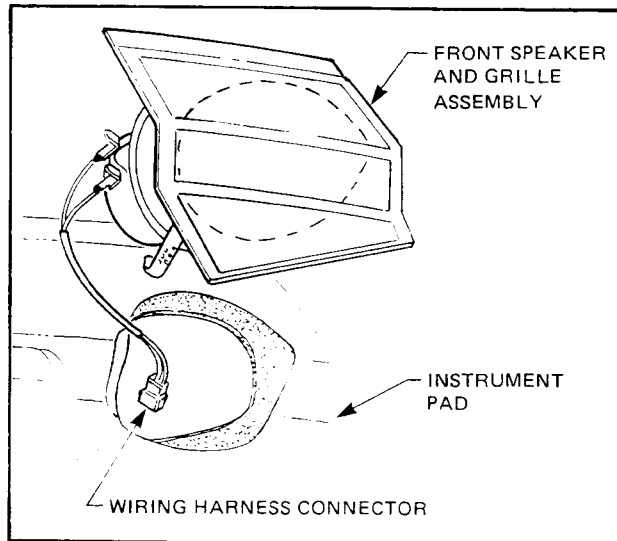

Figure 12D-5

Rear Speakers - Sedan

1. Remove push-on speaker grille.
2. Remove speaker securing screws, refer Fig. 12D-6.

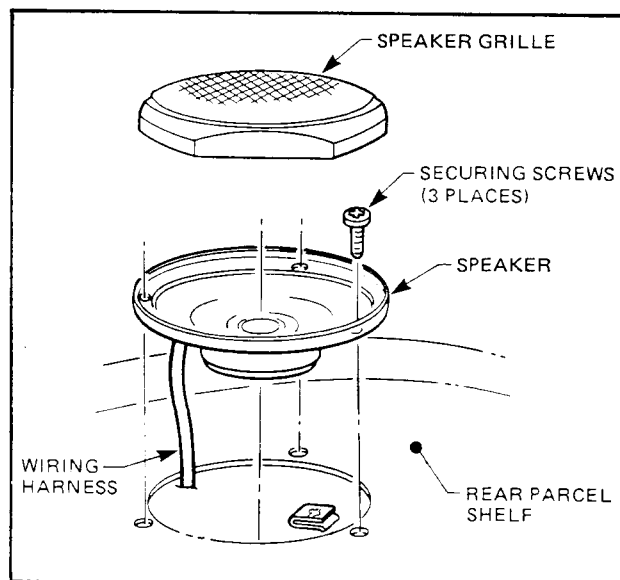

Figure 12D-6

3. Disconnect wiring harness connector, refer Fig. 12D-7, remove speaker.

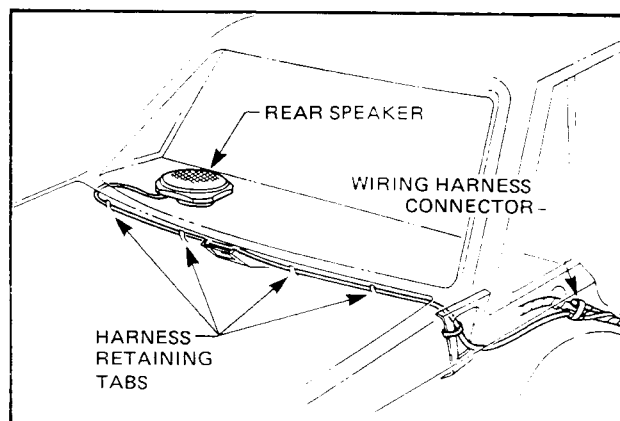

Figure 12D-7

RADIO AND TAPE PLAYER 12D-5

Rear Speaker - Station Wagon

1. Remove the interior side panel trim as per instructions in Section 01 of the Holden Commodore VB Series Station Wagon Supplement Part No. M38265.
2. Disconnect wiring harness connector.
3. Remove speaker securing screws and remove speaker, refer Fig. 12D-8.

REINSTALL

Reinstallation in each case is the reversal of removal procedures.

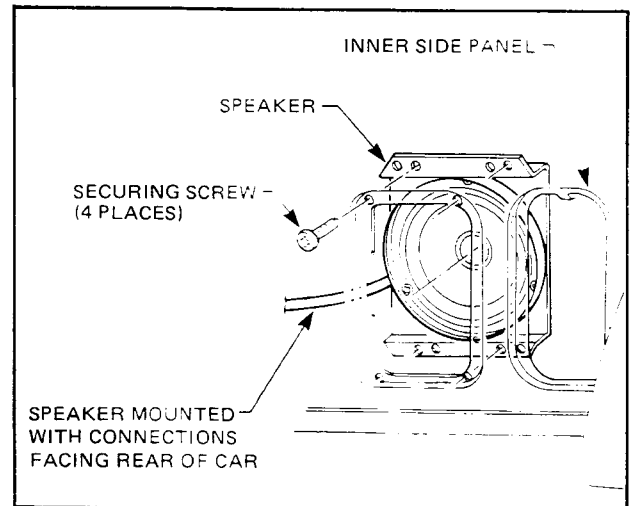
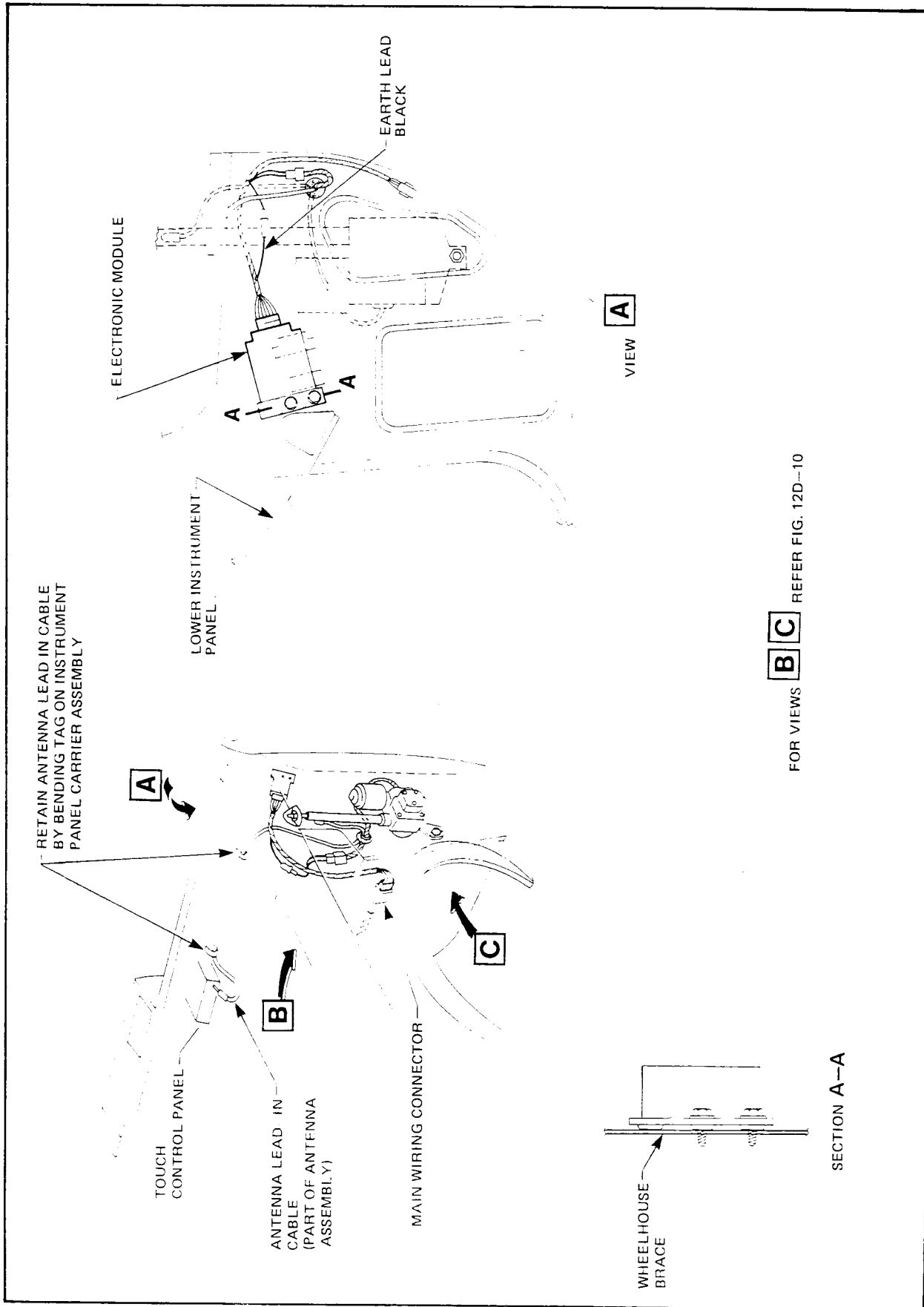

Figure 12D-8

12D-6 RADIO AND TAPE PLAYER



A
VIEW

FOR VIEWS **B** **C** REFER FIG. 12D--10

Figure 12D-9

RADIO AND TAPE PLAYER 12D-7

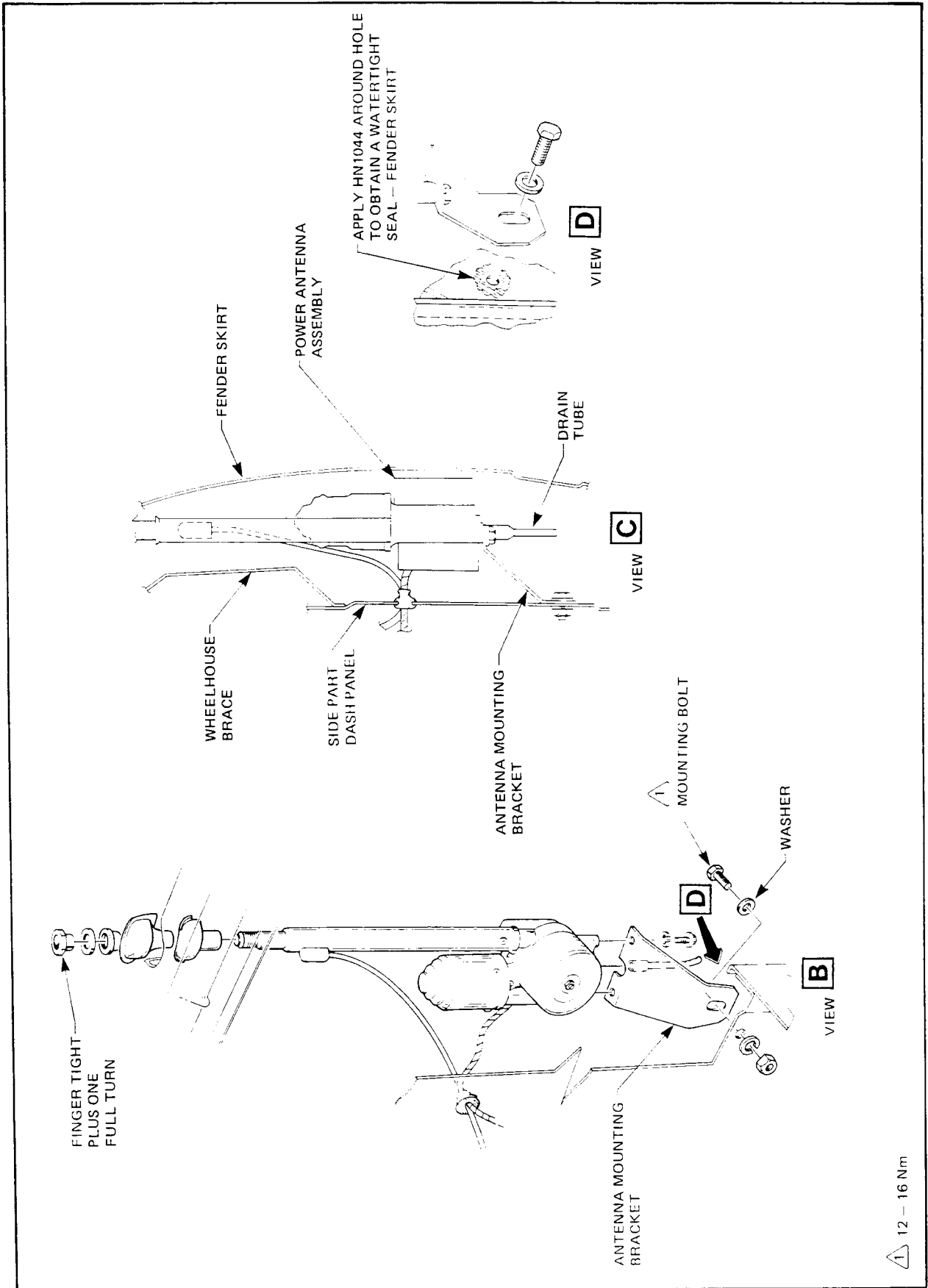
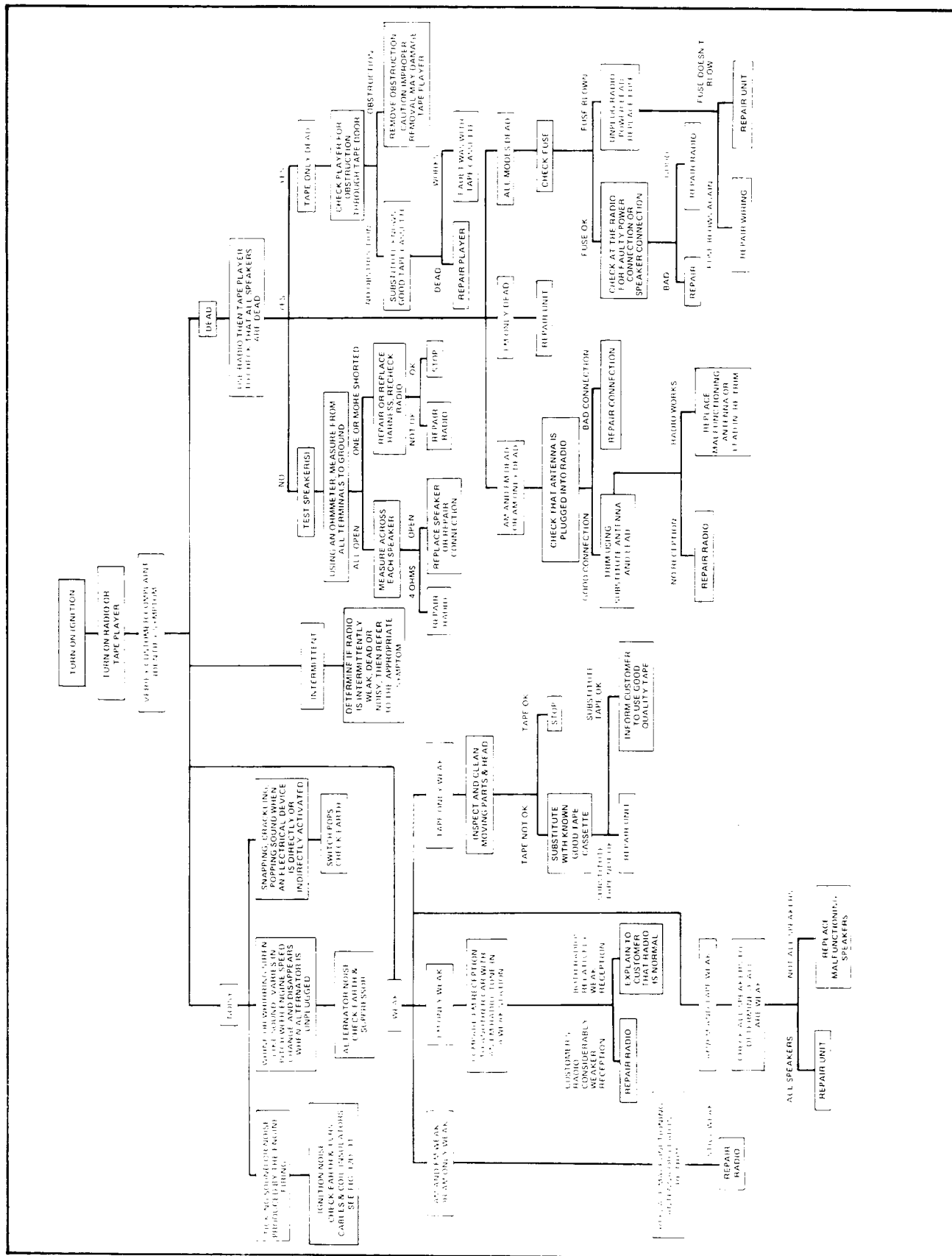

Figure 12D-10

3. DIAGNOSIS



RADIO AND TAPE PLAYER 12D-9

4. SPECIFICATIONS

AM/FM Radio	Stereo, 5W at 10% THD per channel
Radio Cassette	Stereo, 5W at 10% THD per channel
Speakers	4 ohms, 10W capacity
Power Antenna	
Maximum continuous current	3 amps
Lock up current	9 amps

5. TORQUE WRENCH SPECIFICATIONS

Radio – Radio/Cassette Mounting Bracket Screws	0.9 – 1.2 Nm
Antenna Mounting Nut	Finger tight then one complete turn
Power Antenna Mounting Bolts	12 – 16 Nm

6. SPECIAL TOOLS

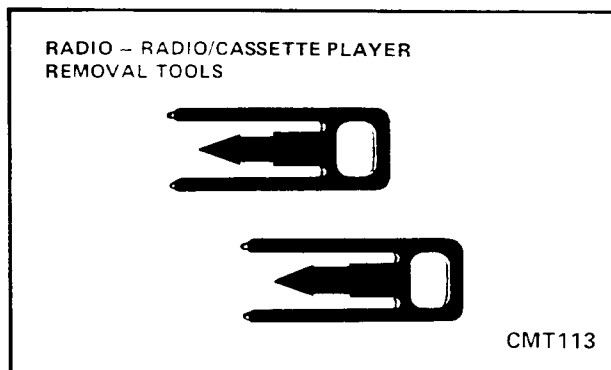

Available from:
Eurovox Australia,
6 University Place,
Clayton North. 3168.

SECTION 12E

WIRING HARNESS AND FUSES

INDEX

Ref.	Subject	Page	Ref.	Subject	Page
1.	FUSE BOX	12E-1	2.1	GENERAL INFORMATION	12E-4
1.1	GENERAL INFORMATION	12E-1		Replace	12E-4
	Remove	12E-3	3.	WIRING HARNESSES	12E-5
	Reinstall	12E-3	3.1	GENERAL INFORMATION	12E-5
2.	FUSIBLE LINK	12E-4	4.	HARNESS DIAGRAMS	12E-5

1. FUSE BOX

1.1 GENERAL INFORMATION

The fuse box used with VK Commodore Series is located in the engine compartment, behind the passenger side strut tower, refer Fig. 12E-1.

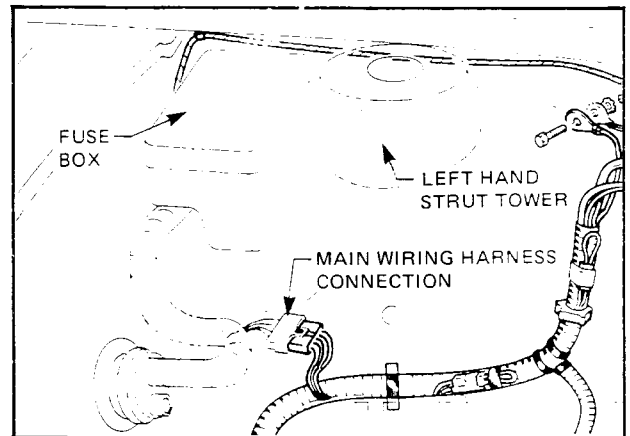

Figure 12E-1

The main wiring harness connections to the fuse box assembly are made via connectors located on the underside of the fuse box, refer Fig. 12E-2.

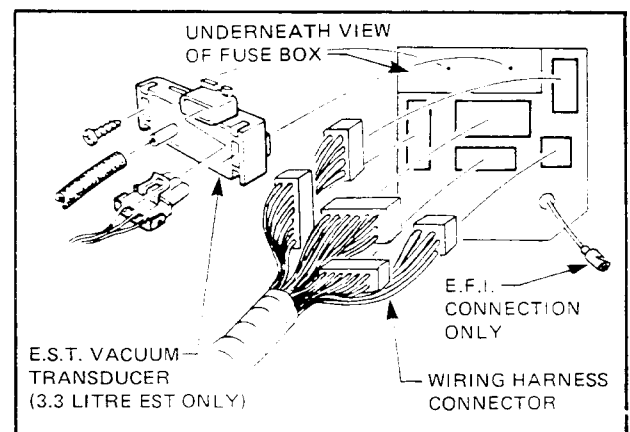

Figure 12E-2

12E-2 WIRING HARNESS & FUSES

Fuses are blade type mini fuses, as used on Camira models, refer Fig. 12E-3.

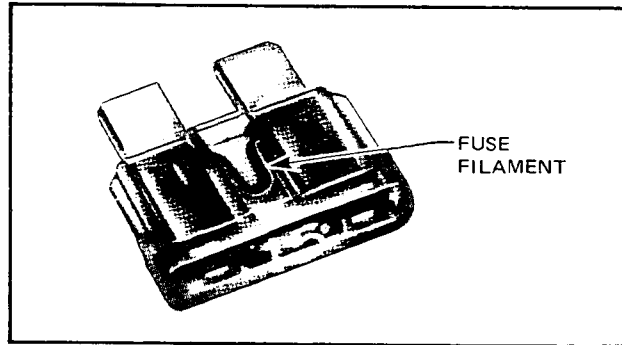

Figure 12E-3

The following chart sets out fuse identification and function.

FUSE NO.	FUNCTION	RATING (AMPS)
1	Headlamps — low beam	15A
2	Headlamps — high beam	15A
3	Parking lamps and Illumination of Instruments	15A
4	Fuel Pump (E.F.I.)	7.5A
	Fuel Pump (5.0 litre)	5.0A
5	Air conditioning blower	25A
6	Horn and stop lights	15A
7	Heated rear window	15A
8	Hazard warning lamps and air conditioning auxiliary fan	15A
9	Clock, trip computer, interior illumination, rear compartment and lock	15A
10	Ignition system	15A
11	Rear window wiper/washer	15A
12	Instruments and trip computer	15A
13	Wiper/washer, turn signal, cigar lighter	15A
14	Radio and power antenna	3A
	Tape and power antenna	7.5A
15	Heater blower	15A
*	Spare fuse	

Refer Fig. 12E-4 for fuse layout

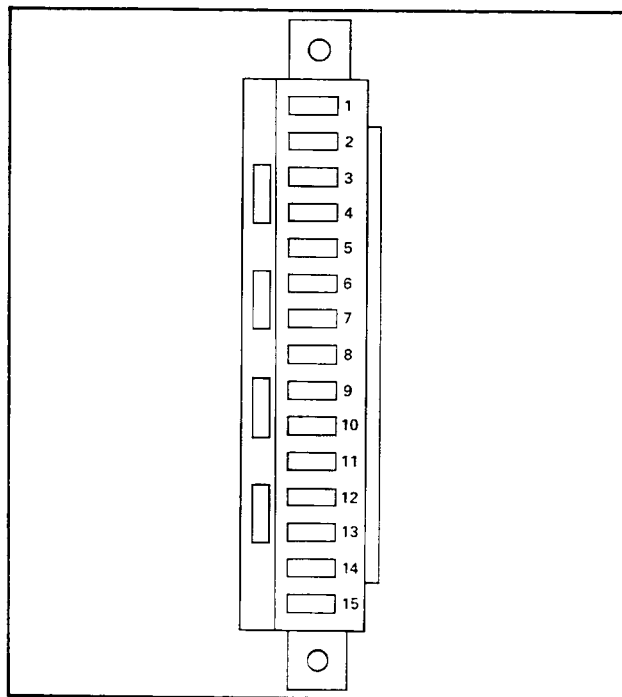

Figure 12E-4

The fuse box also houses a number of relays and control modules, depending on the vehicle's equipment level, refer Fig. 12E-5.

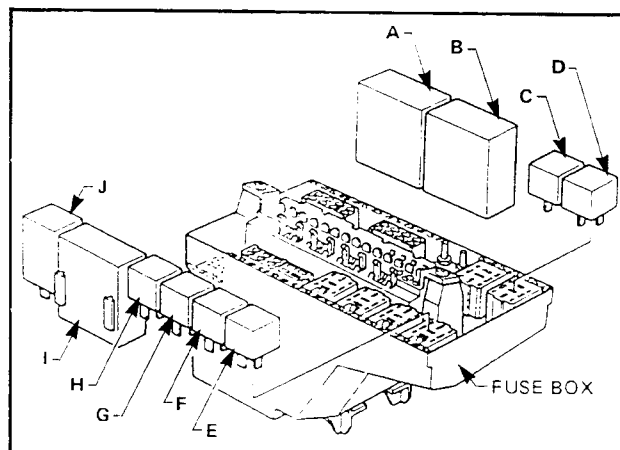

Figure 12E-5

WIRING HARNESS & FUSES 12E-3

NO.	FUNCTION
A	Heated rear window – module
B	Rear window washer/wiper – module
C	Door lock – relay
D	Door lock – relay
E	Horn – relay
F	Power window – relay
G	Air conditioning auxiliary fan – relay
H	Air conditioning blower – relay
I	Air conditioning compressor clutch delay – module
J	Fuel pump control – relay

REMOVE

1. Disconnect battery earth lead.
2. Remove fuse box cover.
3. Remove retaining bolt, refer Fig. 12E-6.
4. Slide fuse box towards the engine to release fuse box from bottom retaining bracket.
5. Lift fuse box up slightly and rotate to gain access underneath box.

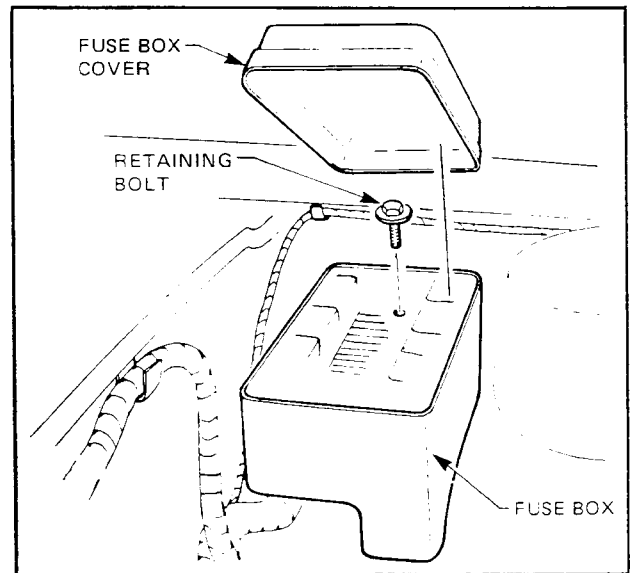

Figure 12E-6

6. Disconnect all wiring harness connectors, refer Fig. 12E-7.
If vehicle is equipped with Electronic Spark Timing, remove the two engine vacuum transducer mounting screws.
7. Lift out fuse box.

REINSTALL

1. Connect all wiring harness connectors. Ensure all are securely installed.
2. Refit EST engine vacuum transducer (if equipped with EST).
3. Engage the tongues on the bottom of the fuse box into the retaining bracket.
4. Fit retaining bolt, fuse box cover and battery earth lead.

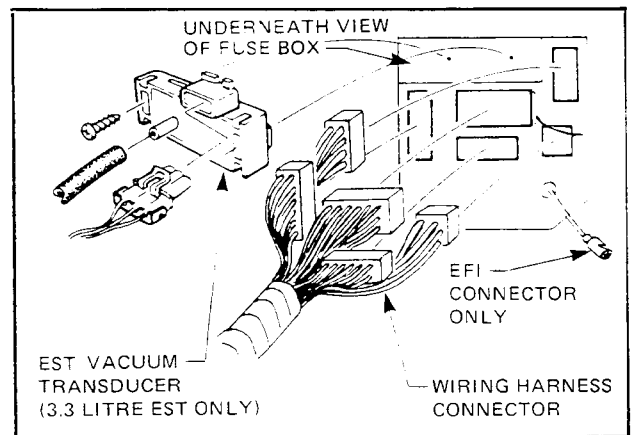

Figure 12E-7

12E-4 WIRING HARNESS & FUSES

2. FUSIBLE LINK

2.1 GENERAL INFORMATION

The chassis wiring is protected against short circuit damage by a fusible link placed within the battery wiring harness.

It is taped back to the battery wiring harness, near the battery, refer Fig. 12E-8.

An additional fusible link is incorporated for 3.3 litre EFI models for EFI wiring harness protection. It is taped back to the battery wiring harness, between the battery and starter motor, refer Fig. 12E-8.

REPLACE

1. Disconnect battery earth lead.
2. Untape fusible link wire from battery wiring harness.
3. Disconnect fusible link connector and install new link, refer Fig. 12E-9.
4. Tape back to harness.
5. Reconnect battery earth terminal.

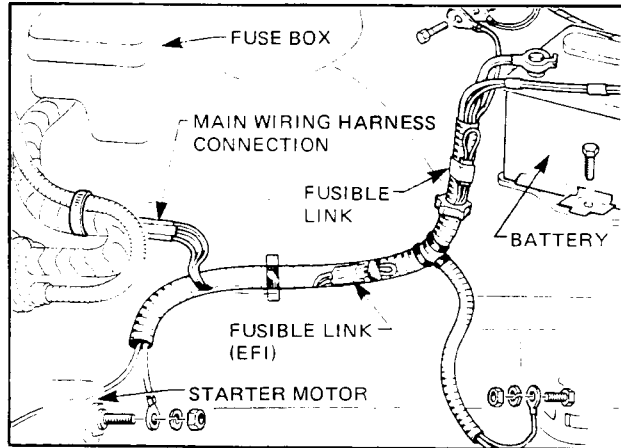

Figure 12E-8

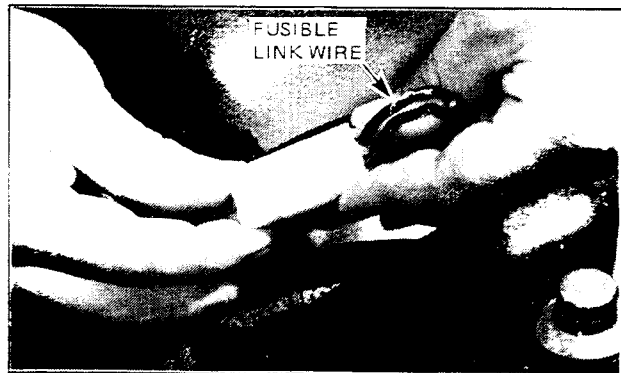

Figure 12E-9

3. WIRING HARNESSES

3.1 GENERAL INFORMATION

All VK series models are served by two main wiring harnesses, plus associated ancillary wiring harnesses, depending upon the equipment level of the vehicle.

1. Main Wiring Harness

There are two levels of main wiring harness. The lower level carries only the base options and accommodates EST only.

The upper level accommodates all available options including any EFI circuits.

2. Engine Harness

Different engine harness assemblies are used for 3.3 litre EST, EFI and 5.0 litre.

3. Battery Harness

A different battery harness is used for each engine application.

4. Instrument Panel Harness

There are two different levels of instrument panel harness.

- a. Mechanical instruments and touch switches.
- b. Electronic instruments and touch switches.

Ancillary harnesses are required when various equipment level options are exercised.

- a. Air conditioning.
- b. Power antenna.
- c. Power windows and door locks.
- d. Power operated external mirrors.
- e. Reading lamps.
- f. Heated rear window.
- g. Rear speakers.
- h. Rear lamps.

12E-6 WIRING HARNESS & FUSES

4. HARNESS DIAGRAMS

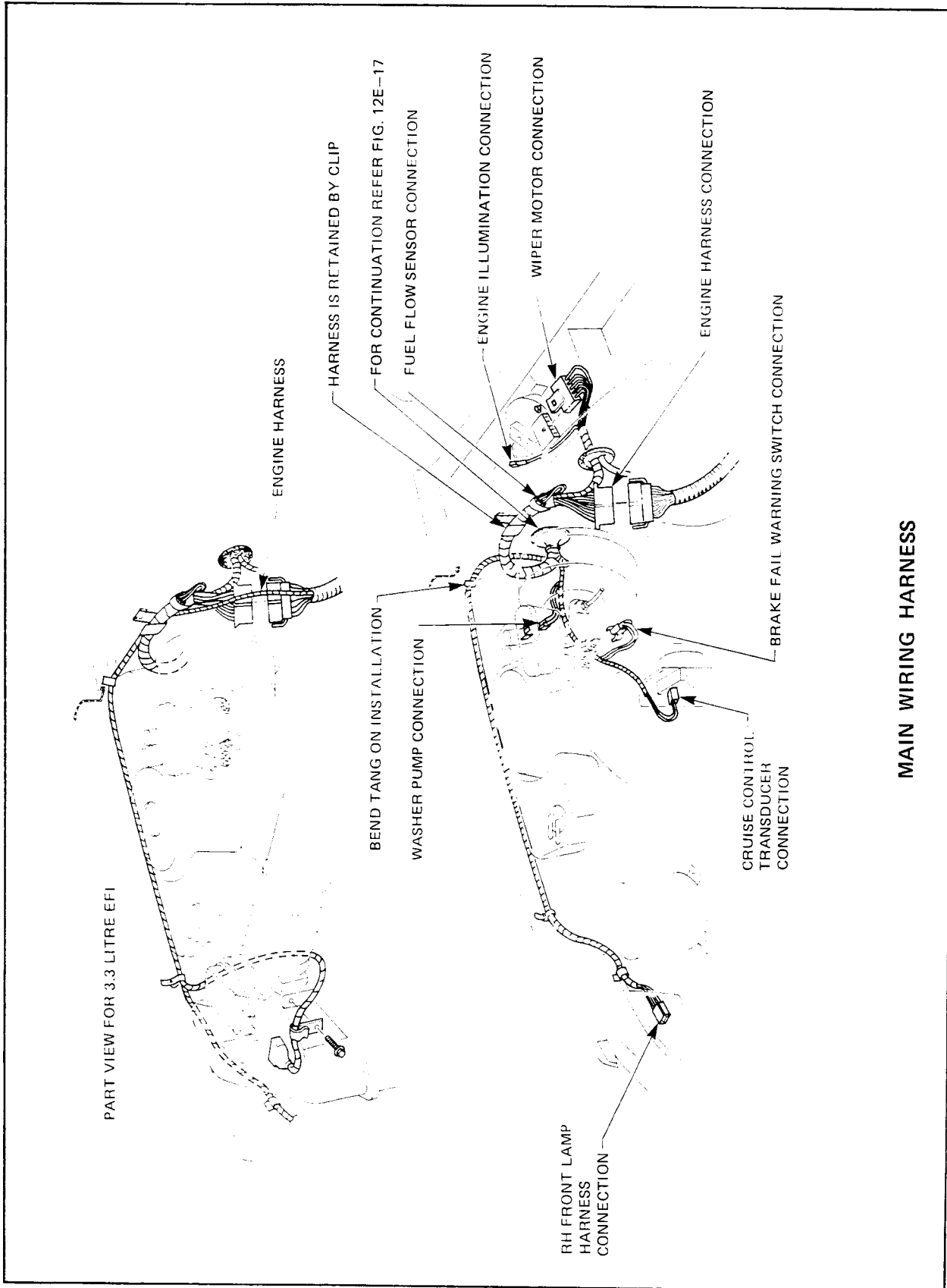
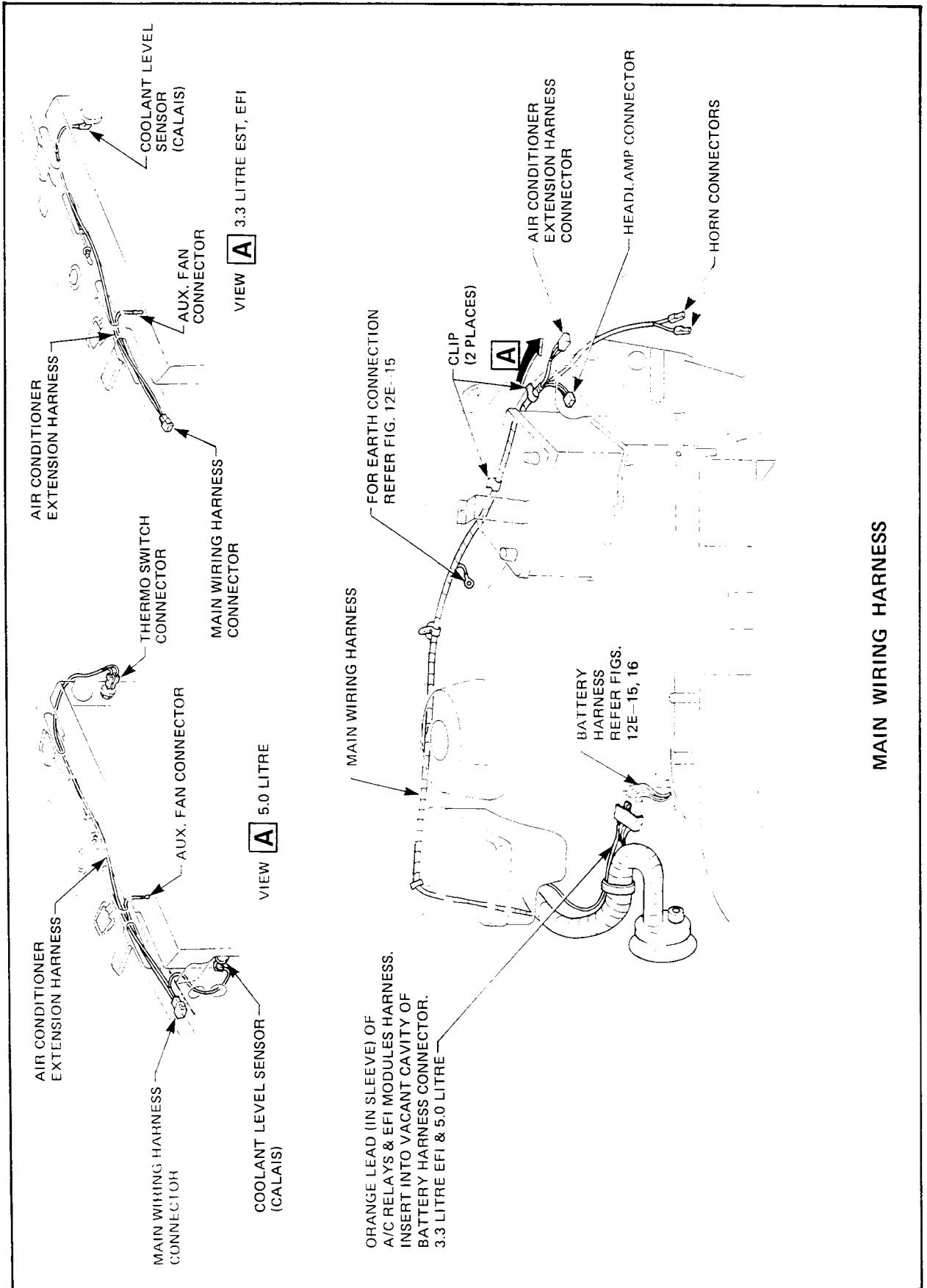

Figure 12E-10



MAIN WIRING HARNESS

Figure 12E-11

12E-8 WIRING HARNESS & FUSES

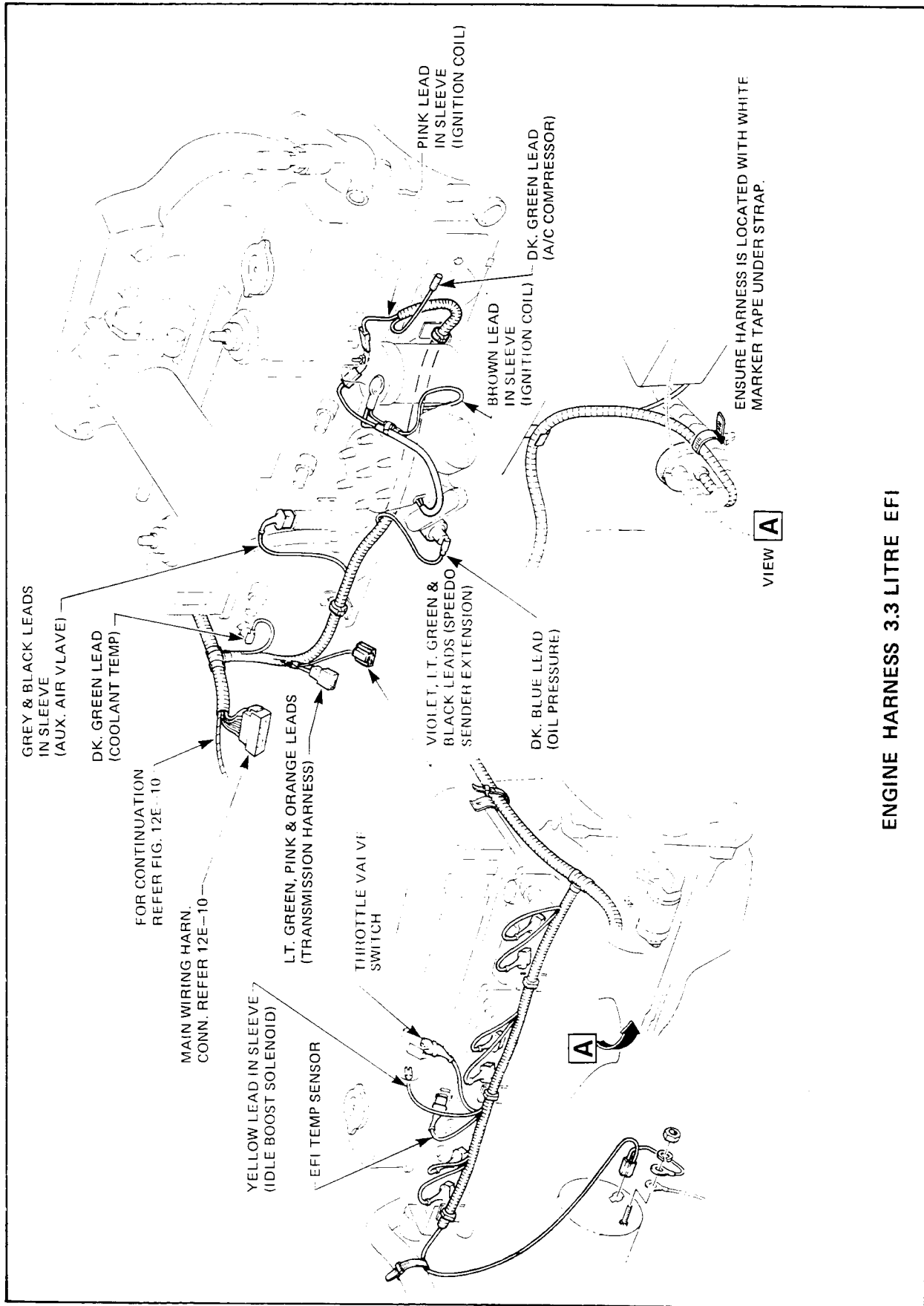

ENGINE HARNESS 3.3 LITRE EFI

Figure 12E-12

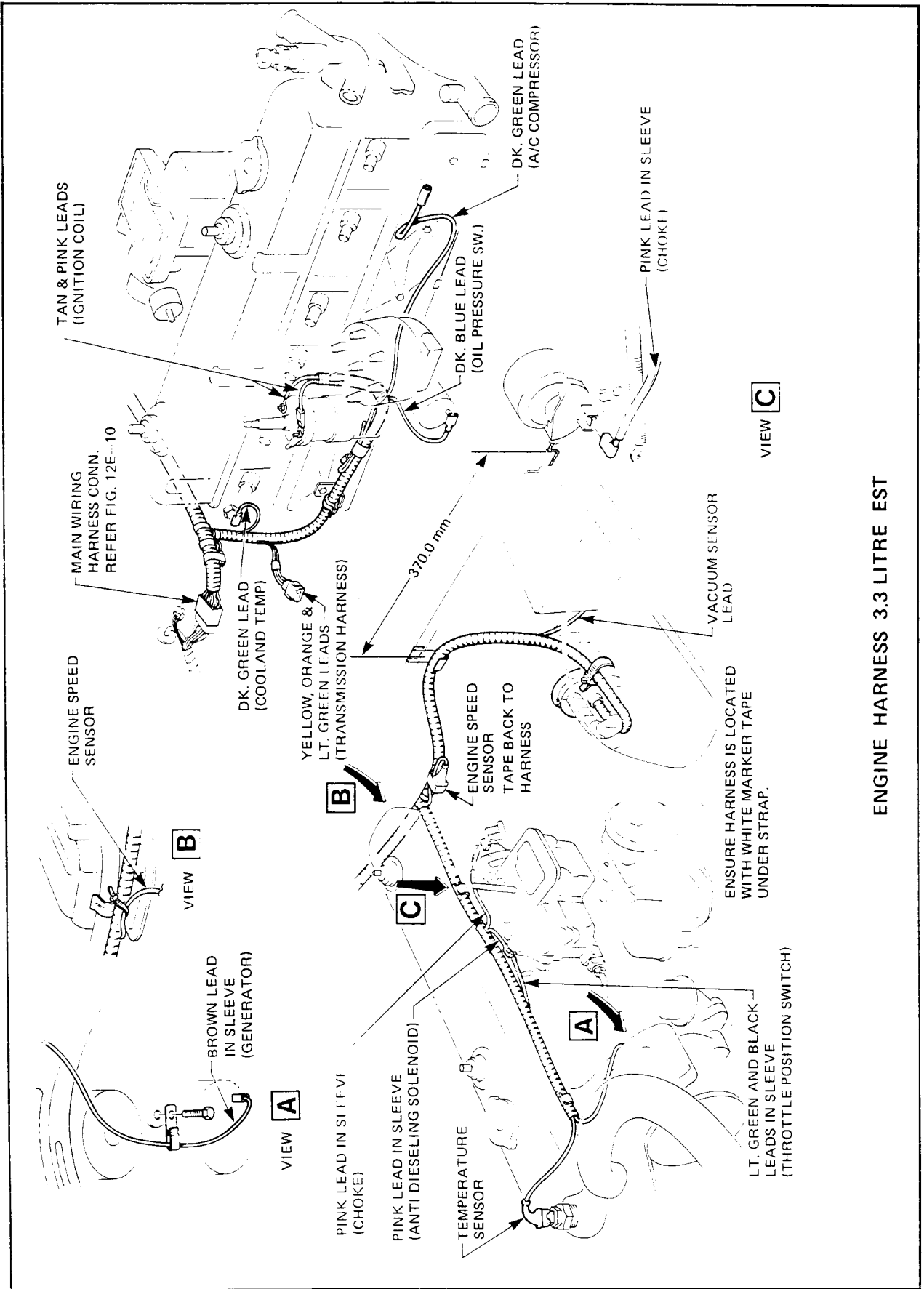

ENGINE HARNESS 3.3 LITRE EST

Figure 12E-13

12E-10 WIRING HARNESS & FUSES

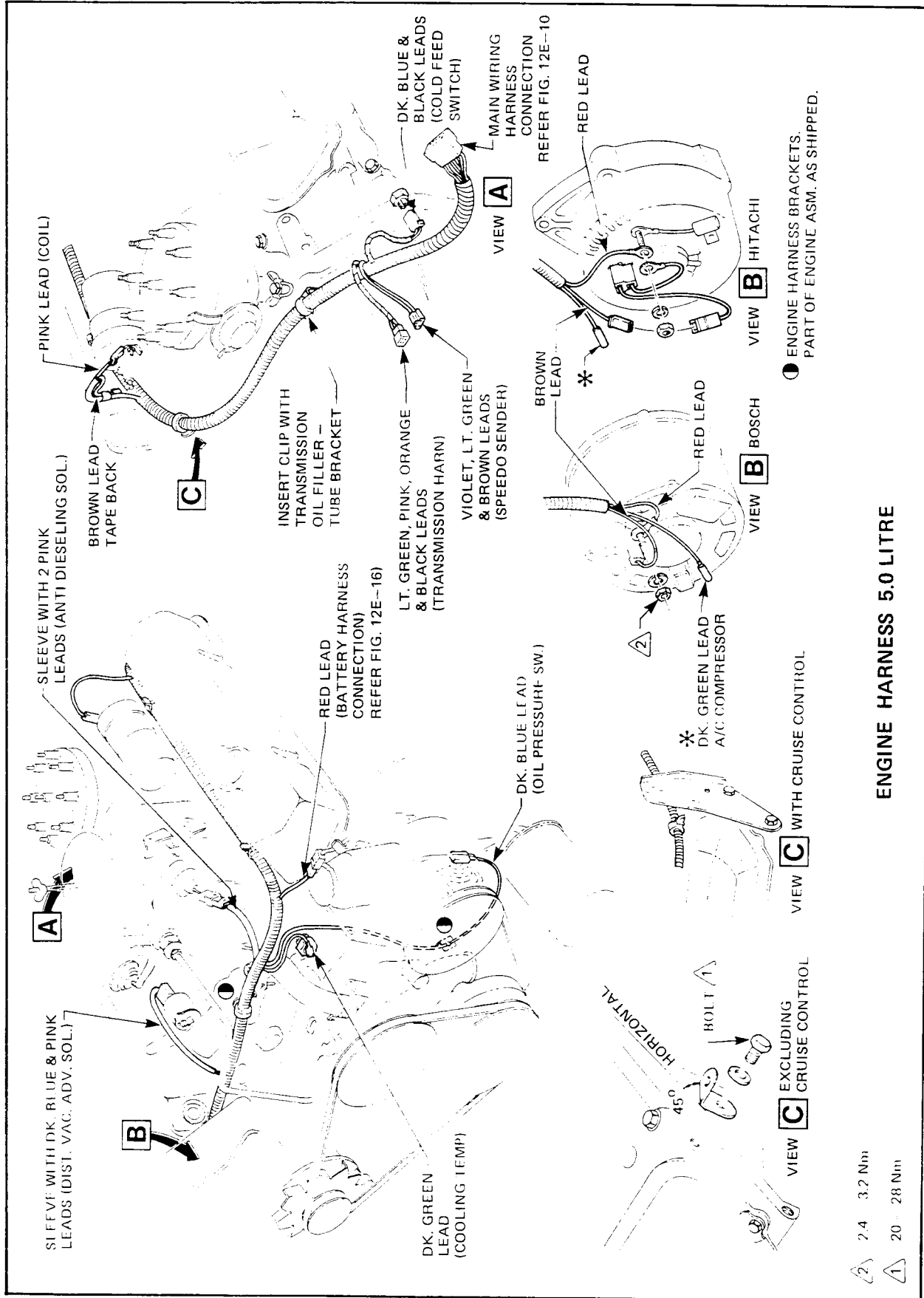

Figure 12E-14

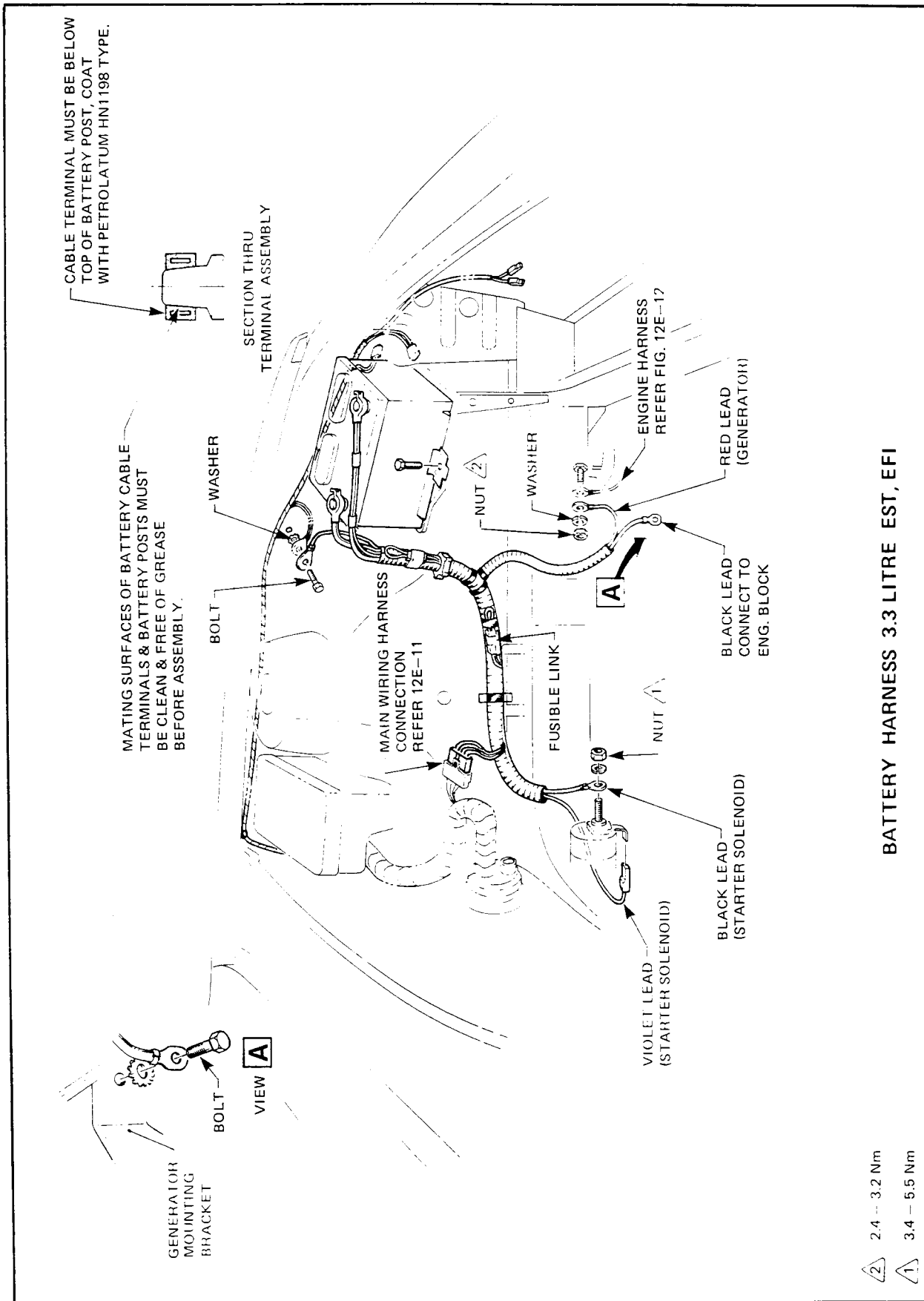

Figure 12E-15

12E-12 WIRING HARNESS & FUSES

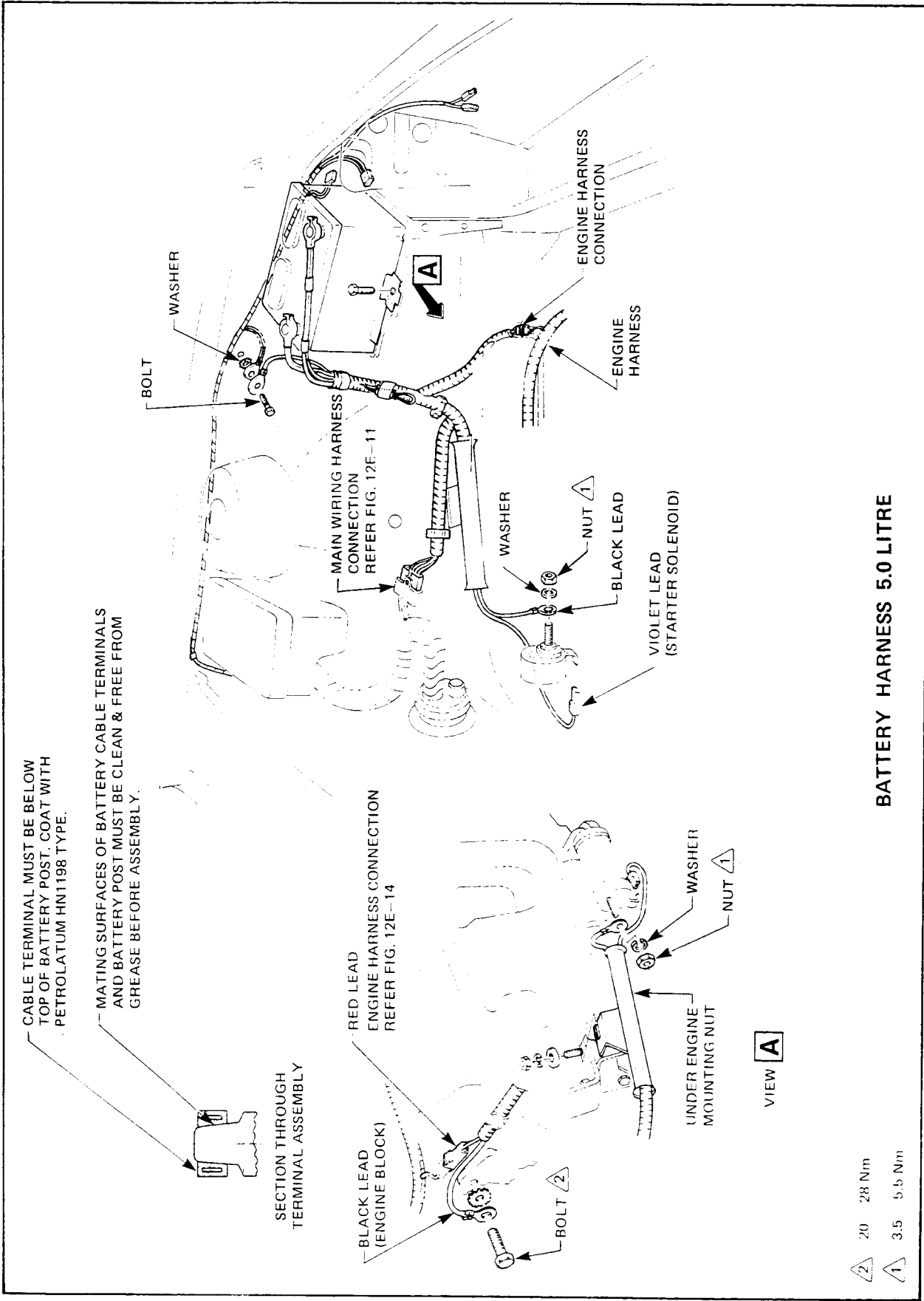
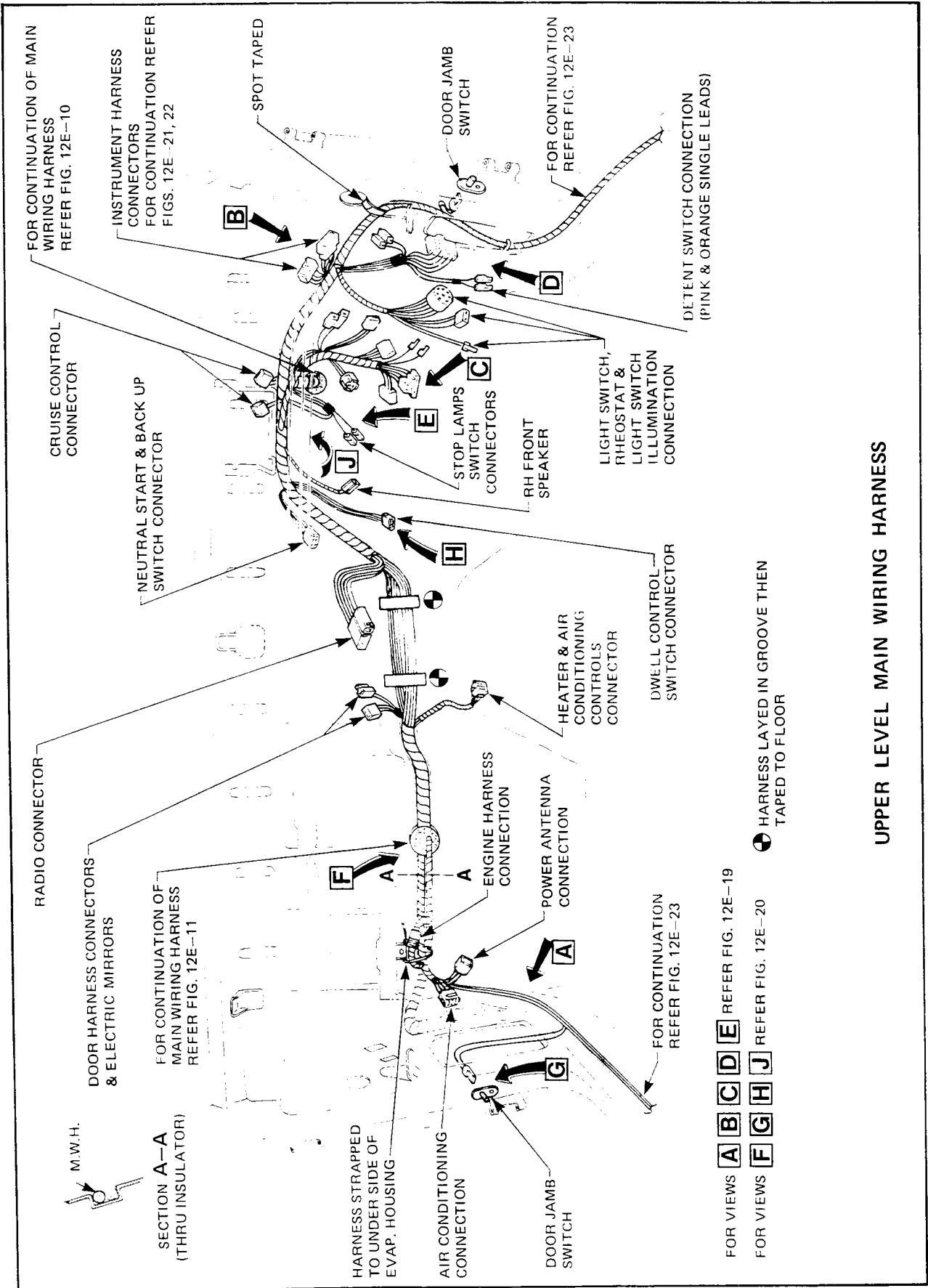

Figure 12E-16



UPPER LEVEL MAIN WIRING HARNESS

Figure 12E-17

12E-14 WIRING HARNESS & FUSES

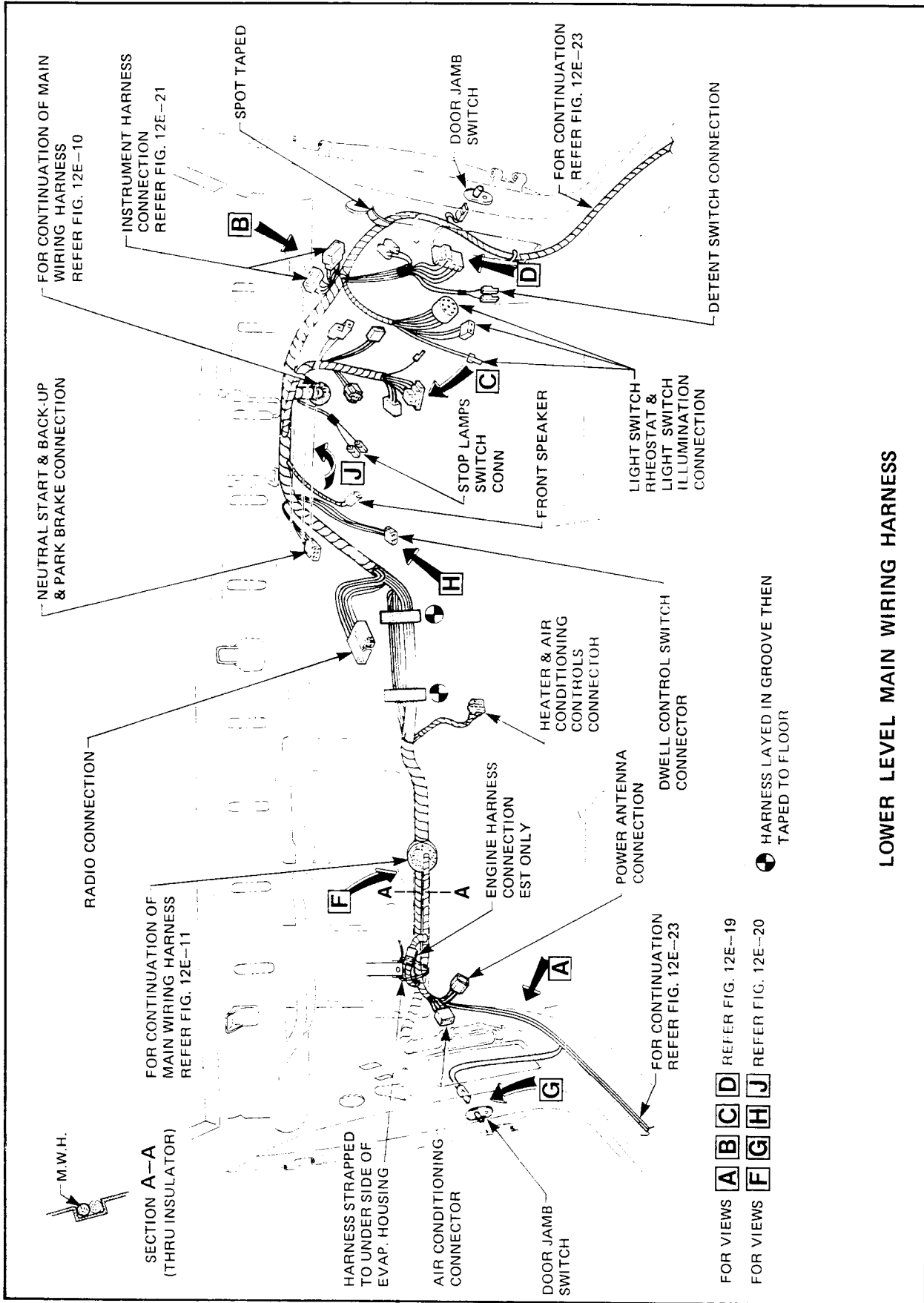

LOWER LEVEL MAIN WIRING HARNESS

Figure 12E-18

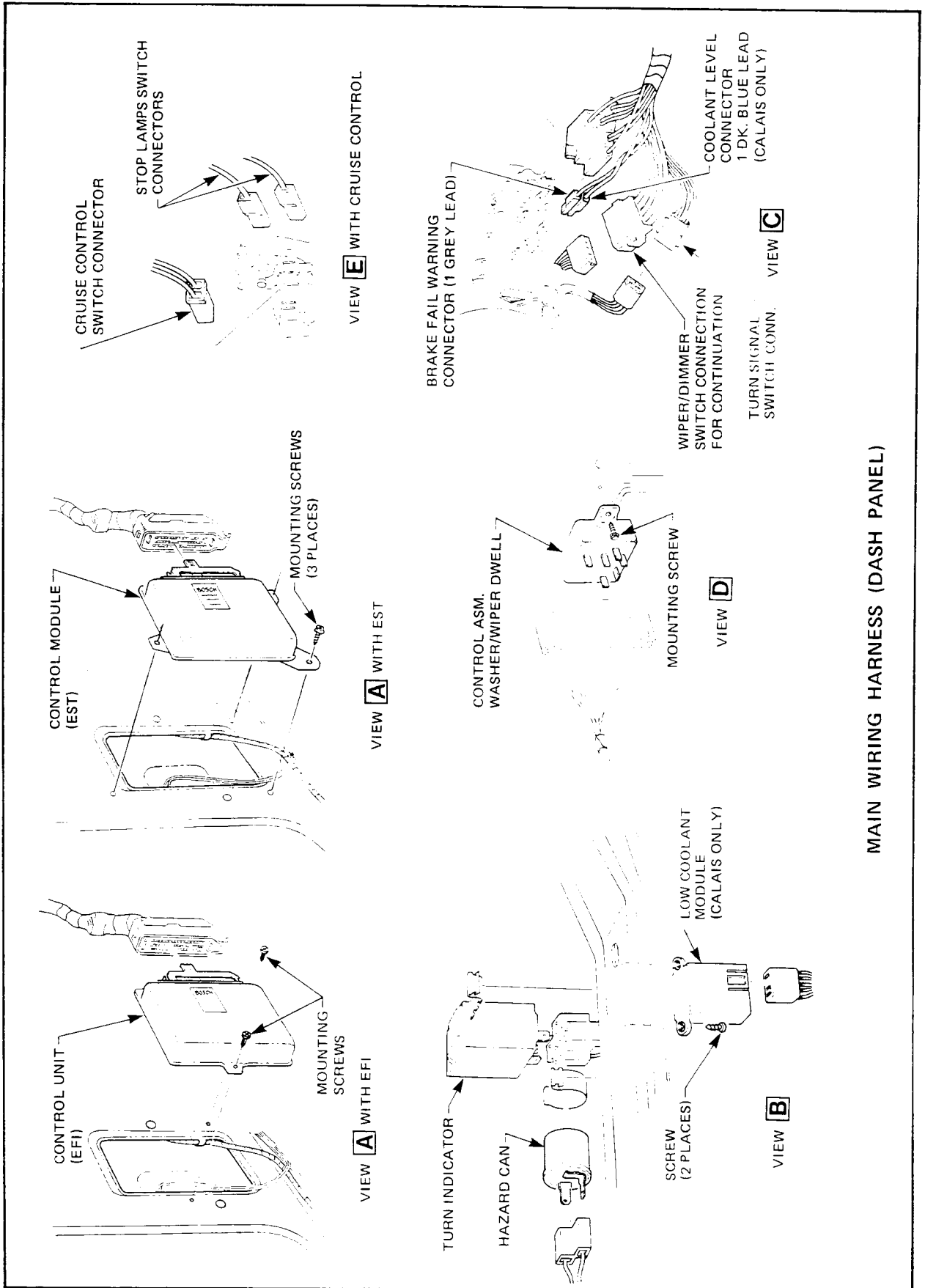

MAIN WIRING HARNESS (DASH PANEL)

Figure 12E-19

12E-16 WIRING HARNESS & FUSES

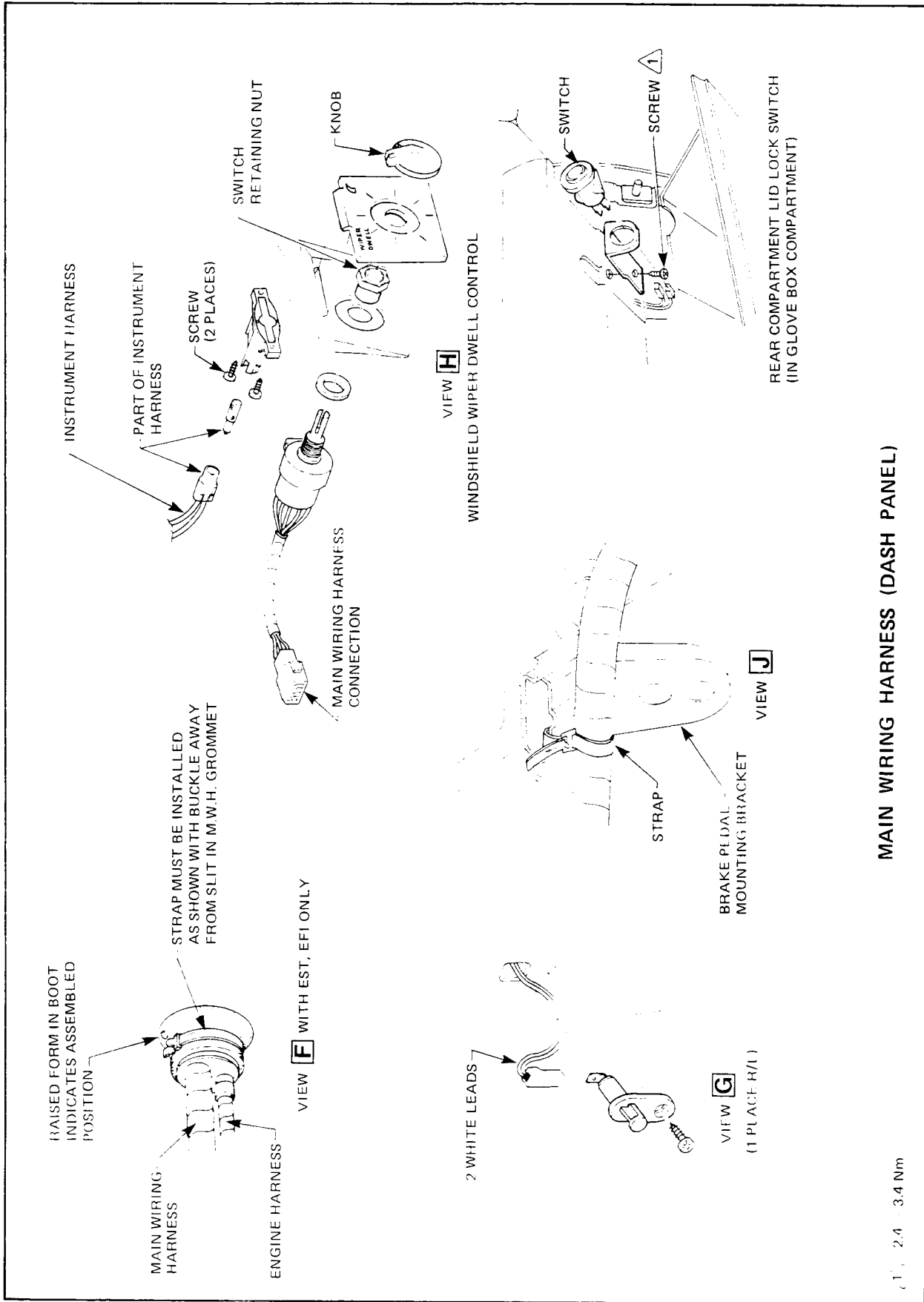

MAIN WIRING HARNESS (DASH PANEL)

T1 2.4 - 3.4 Nm

Figure 12E-20

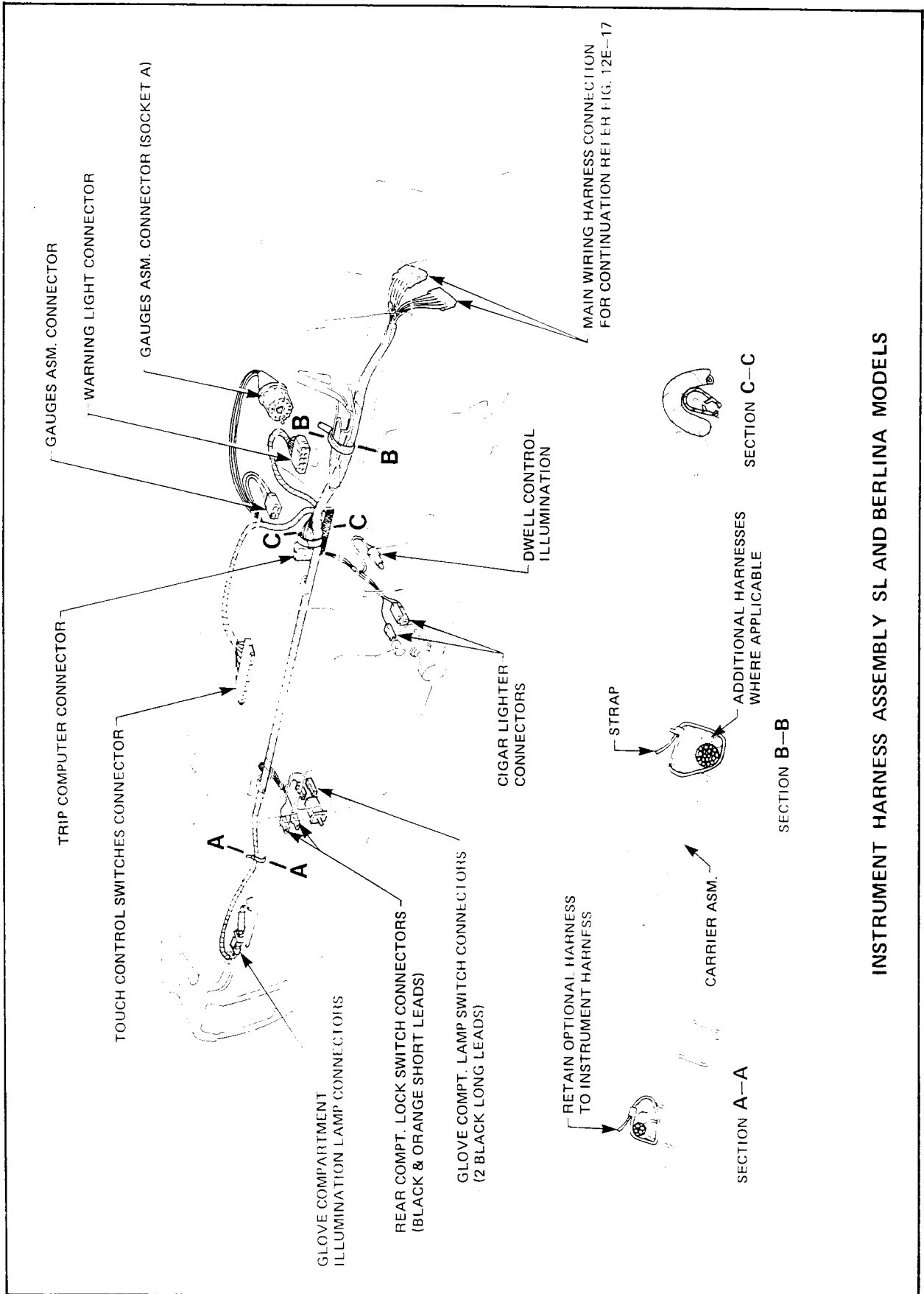

INSTRUMENT HARNESS ASSEMBLY SL AND BERLINA MODELS

12E-18 WIRING HARNESS & FUSES

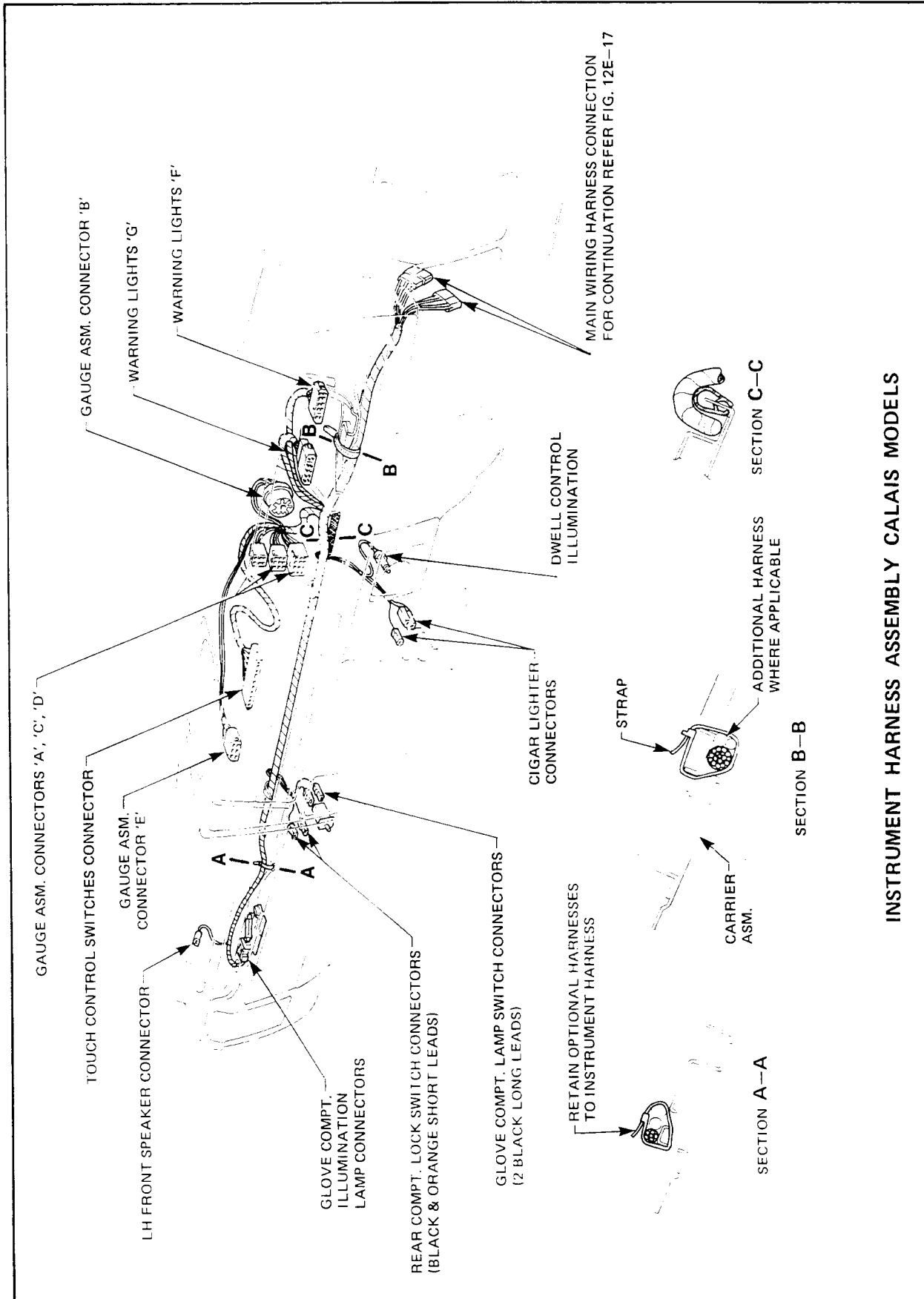

INSTRUMENT HARNESS ASSEMBLY CALAIS MODELS

Figure 12E-22

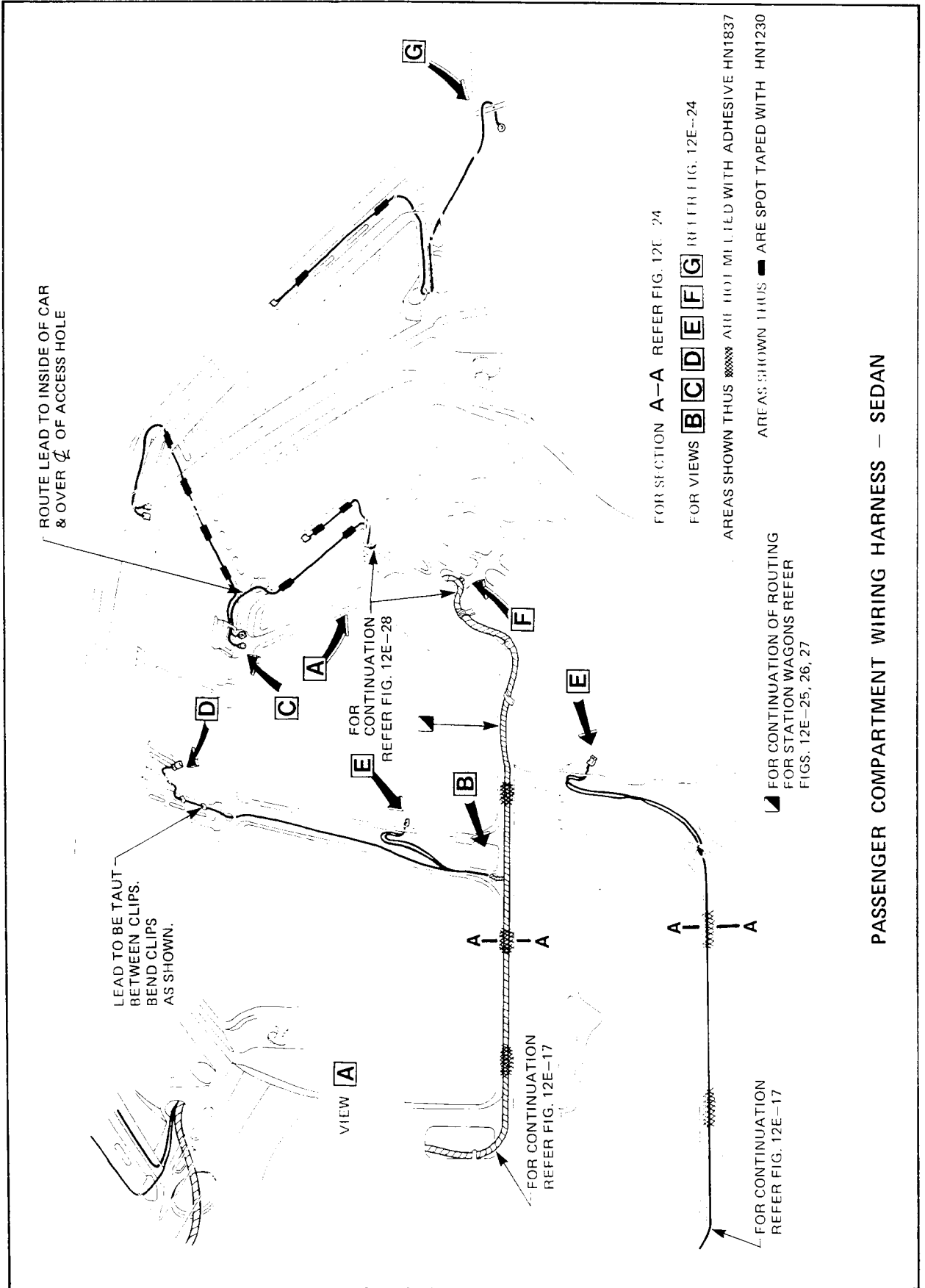

PASSENGER COMPARTMENT WIRING HARNESS - SEDAN

Figure 12E-23

12E-20 WIRING HARNESS & FUSES

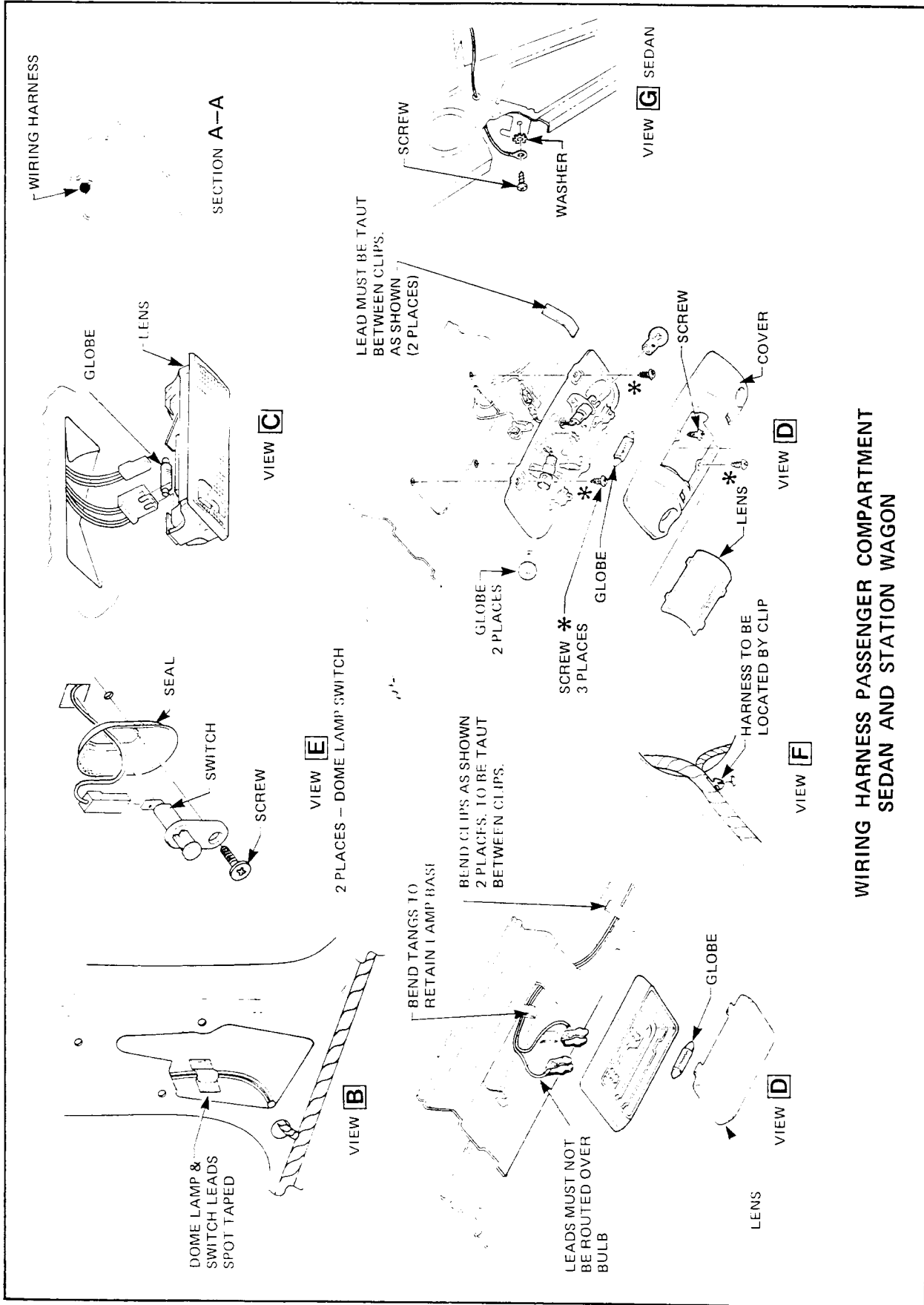

WIRING HARNESS PASSENGER COMPARTMENT
SEDAN AND STATION WAGON

Figure 12E-24

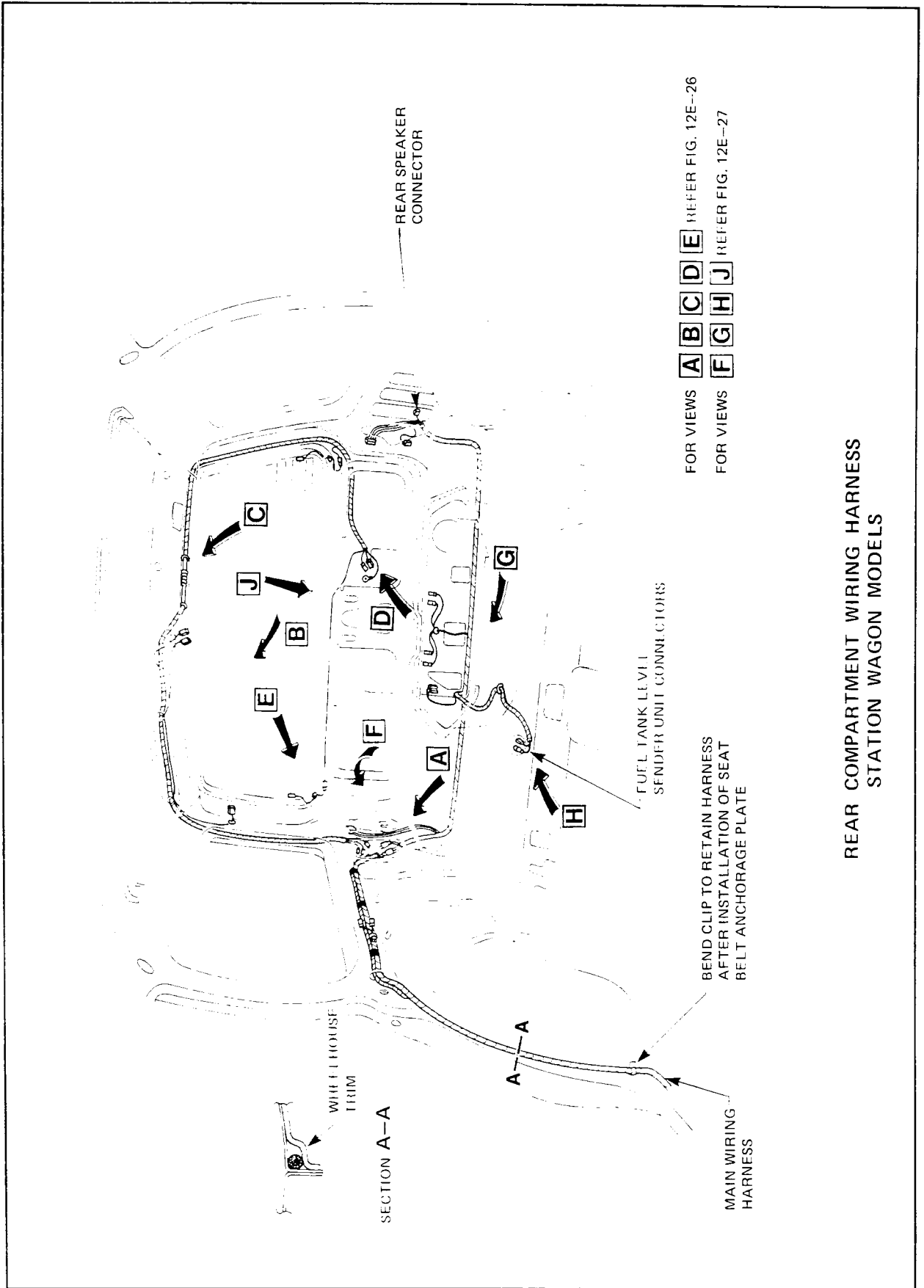

REAR COMPARTMENT WIRING HARNESS
STATION WAGON MODELS

12E-22 WIRING HARNESS & FUSES

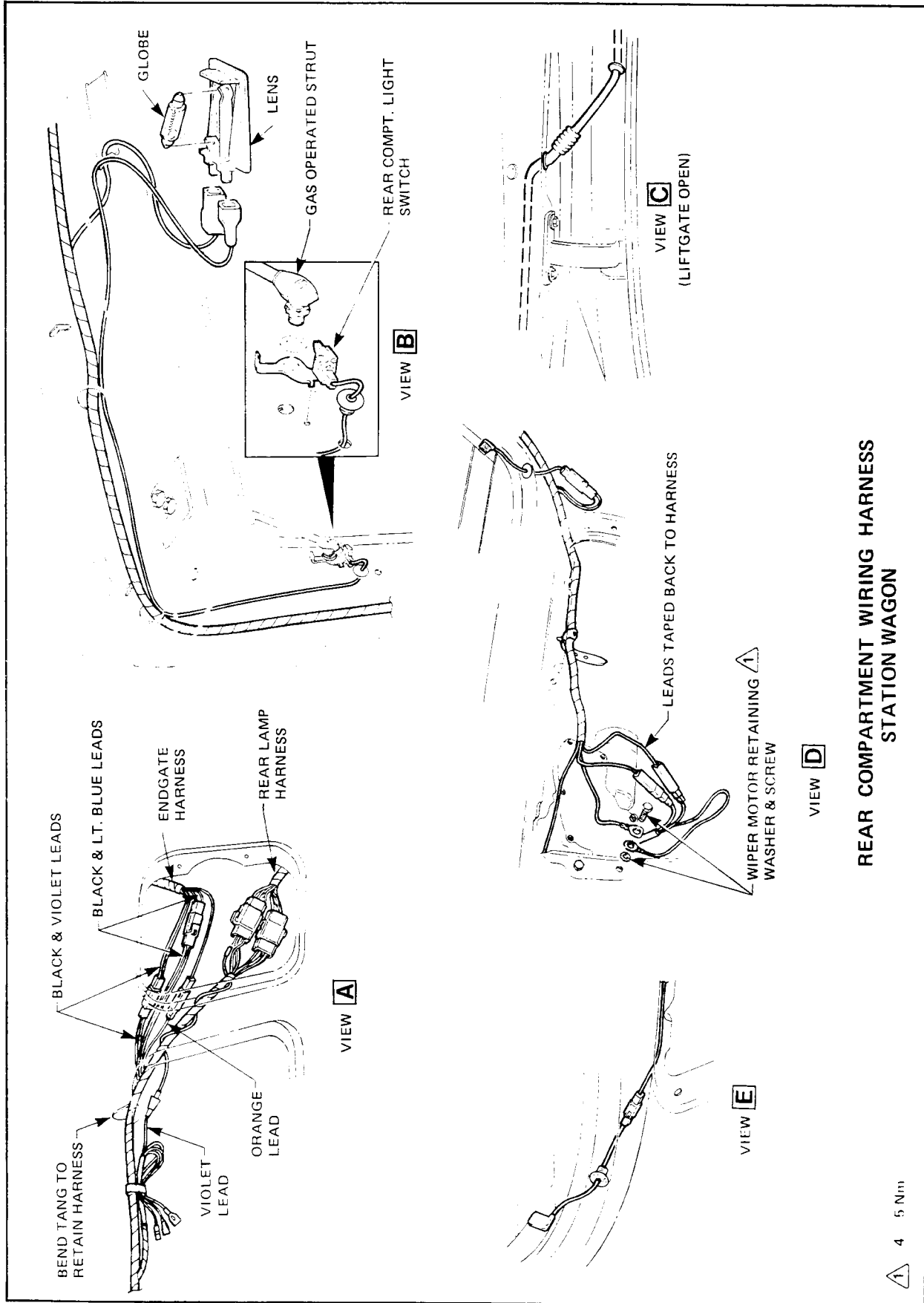

REAR COMPARTMENT WIRING HARNESS
STATION WAGON

Figure 12E-26

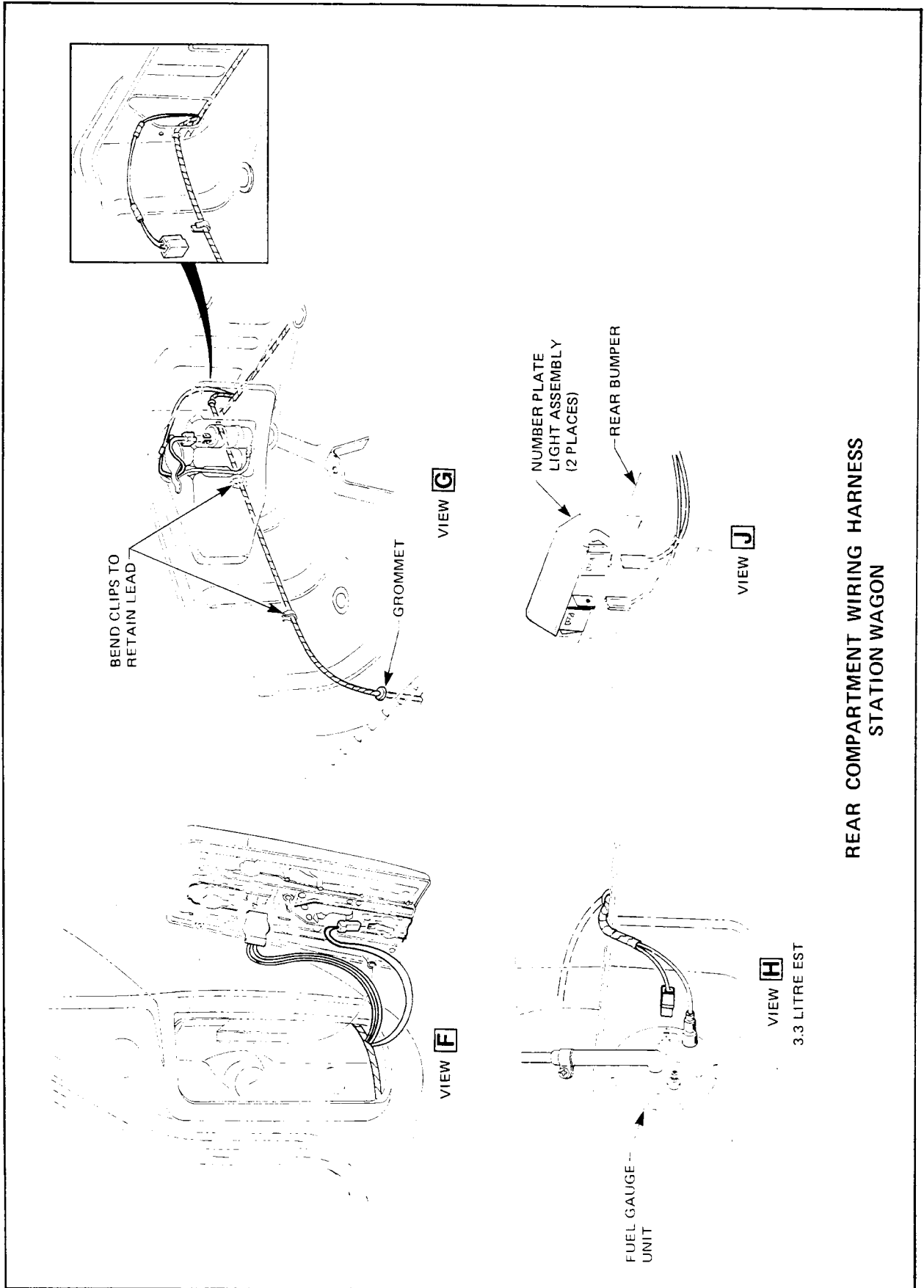

REAR COMPARTMENT WIRING HARNESS
STATION WAGON

Figure 12E-27

12E-24 WIRING HARNESS & FUSES

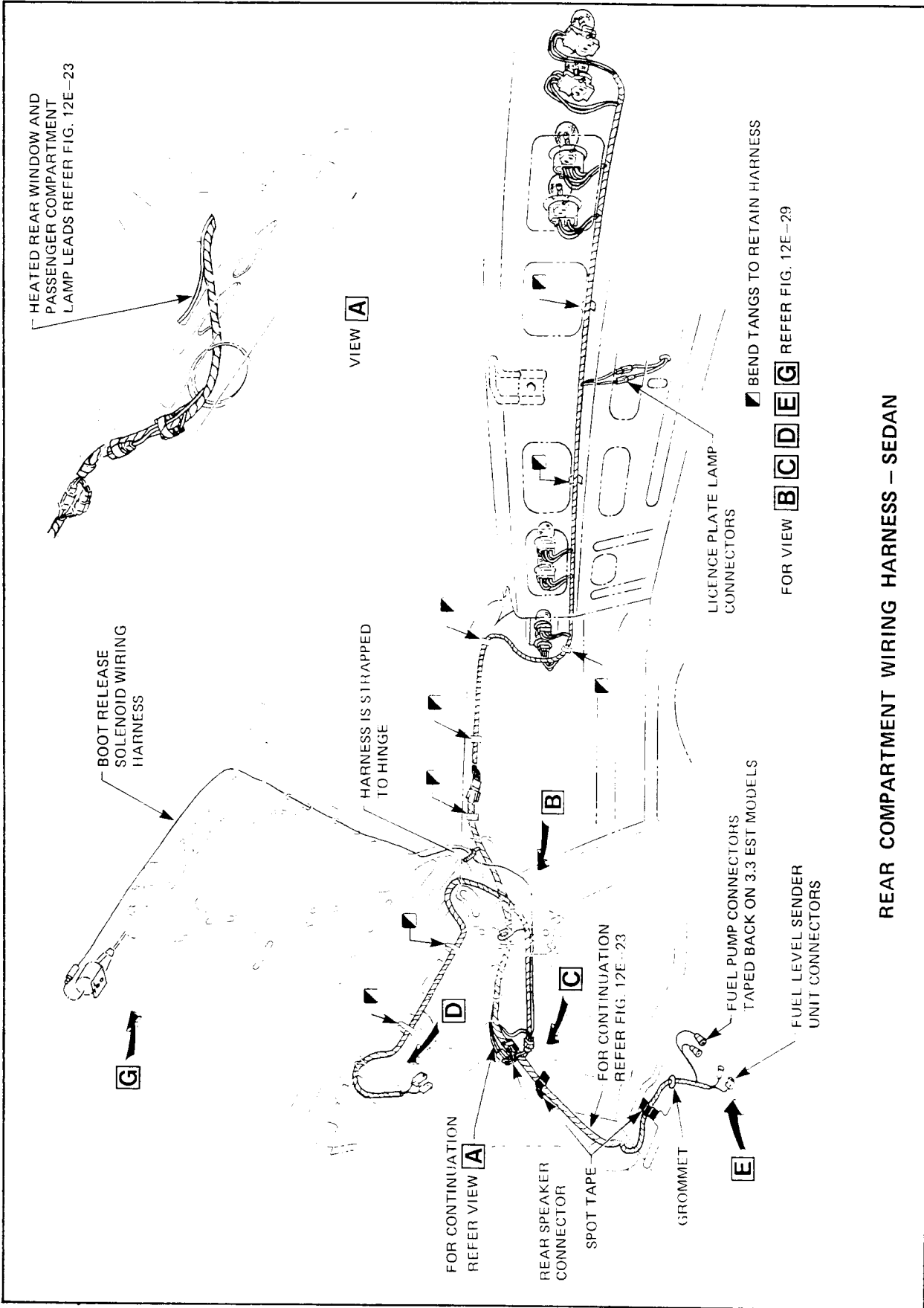

Figure 12E-28

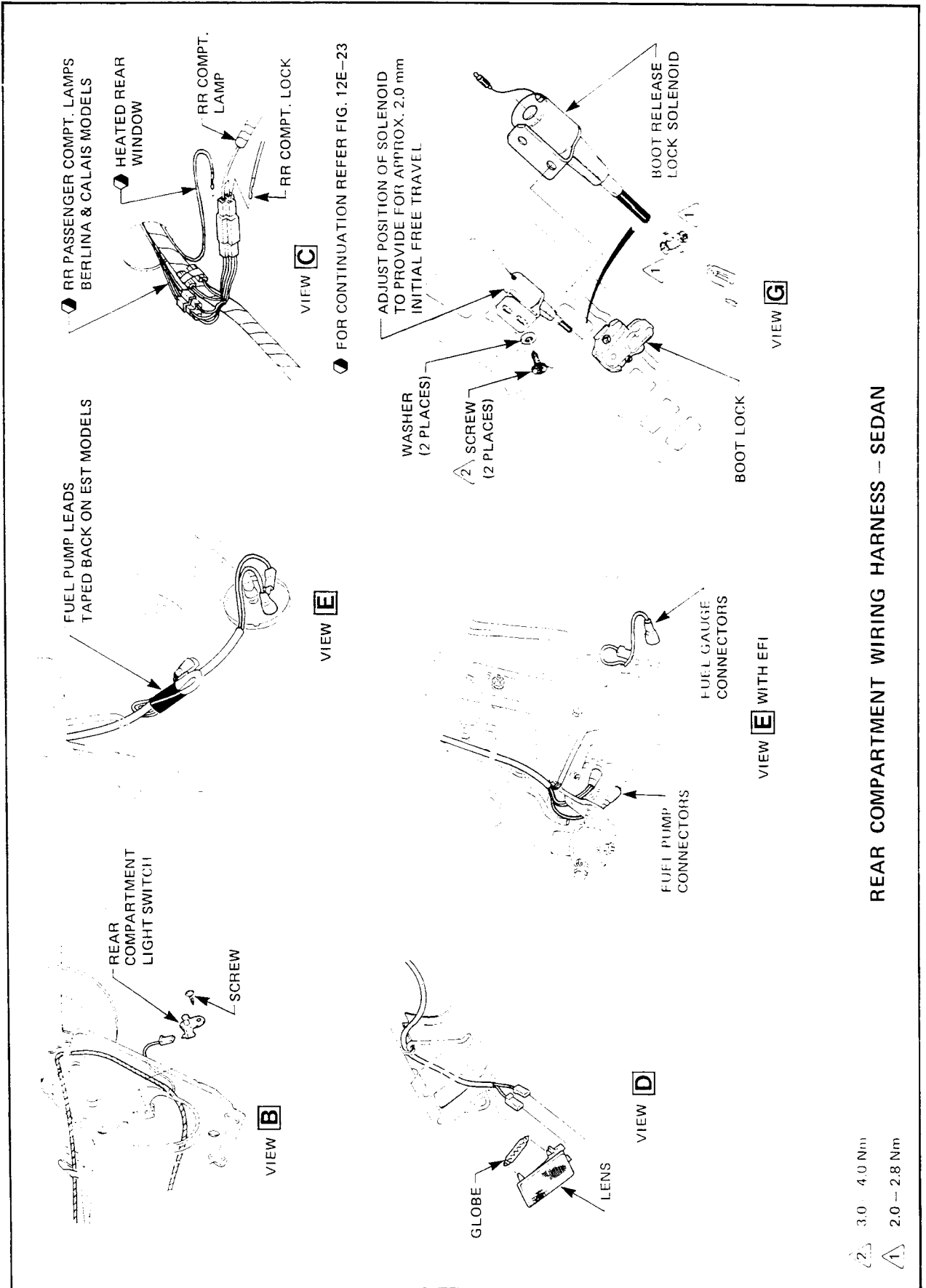
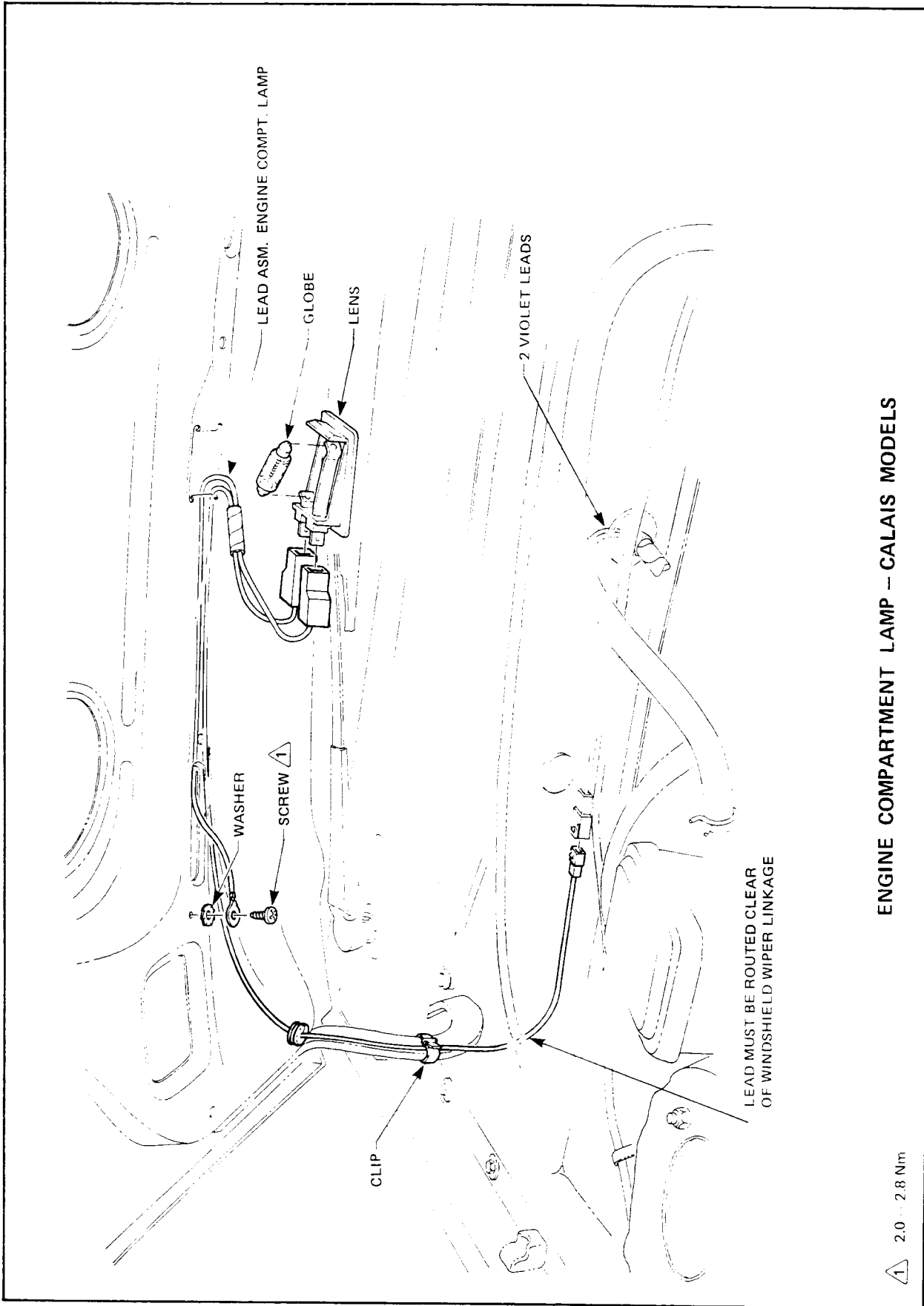
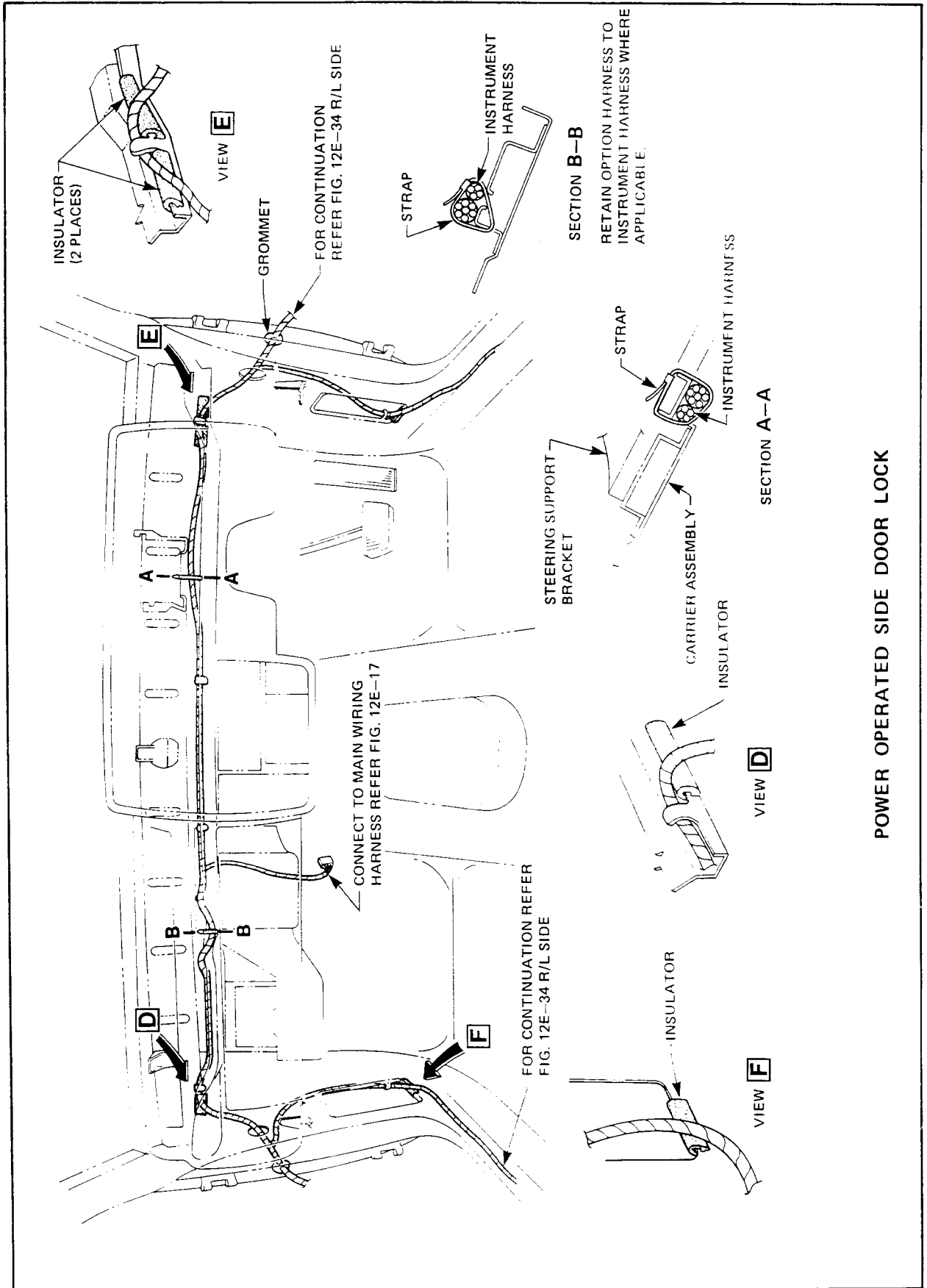

Figure 12E-29

12E-26 WIRING HARNESS & FUSES





POWER OPERATED SIDE DOOR LOCK

Figure 12E-31

12E-28 WIRING HARNESS & FUSES

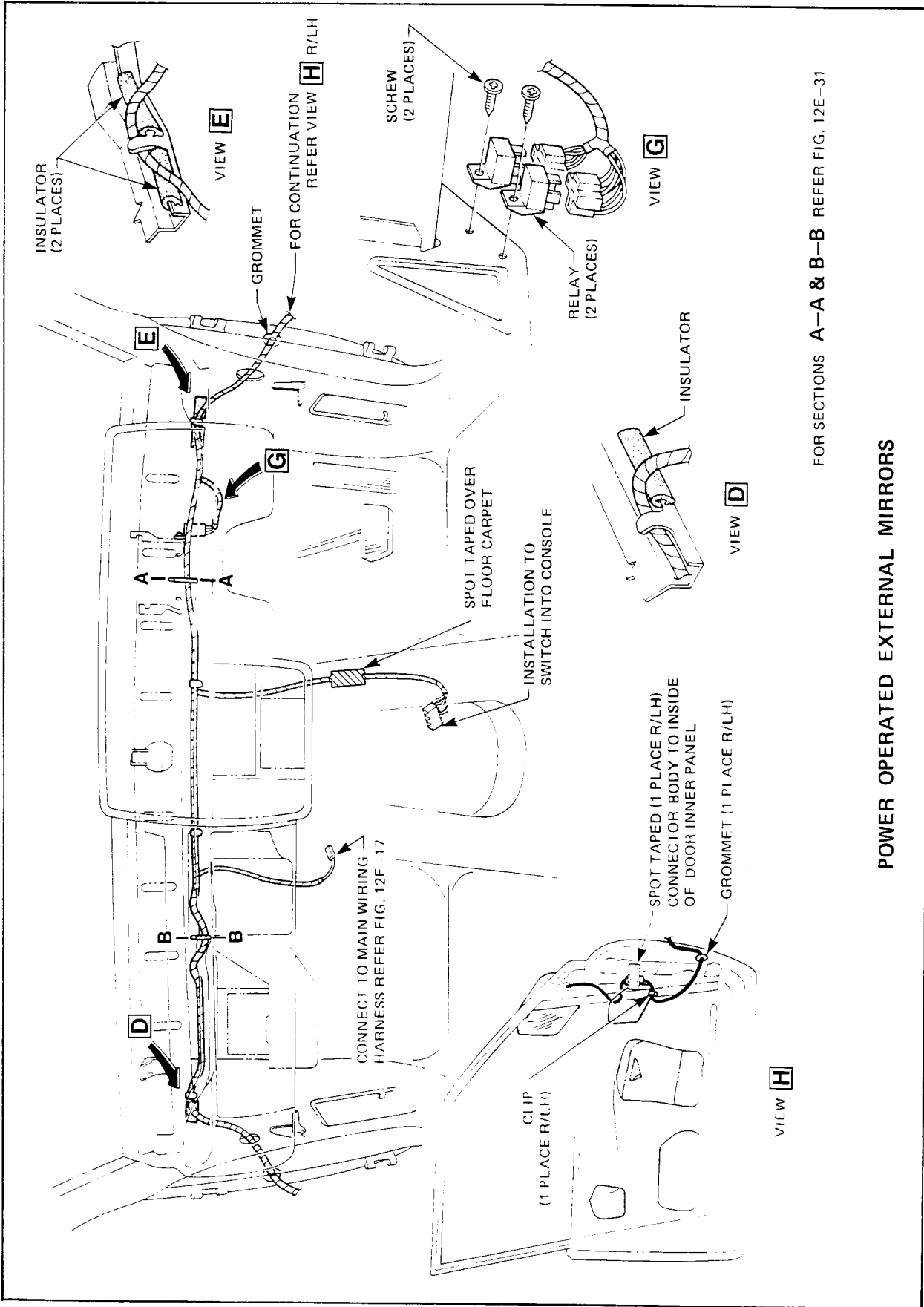

FOR SECTIONS A-A & B-B REFER FIG. 12E-31

POWER OPERATED EXTERNAL MIRRORS

Figure 12E-32

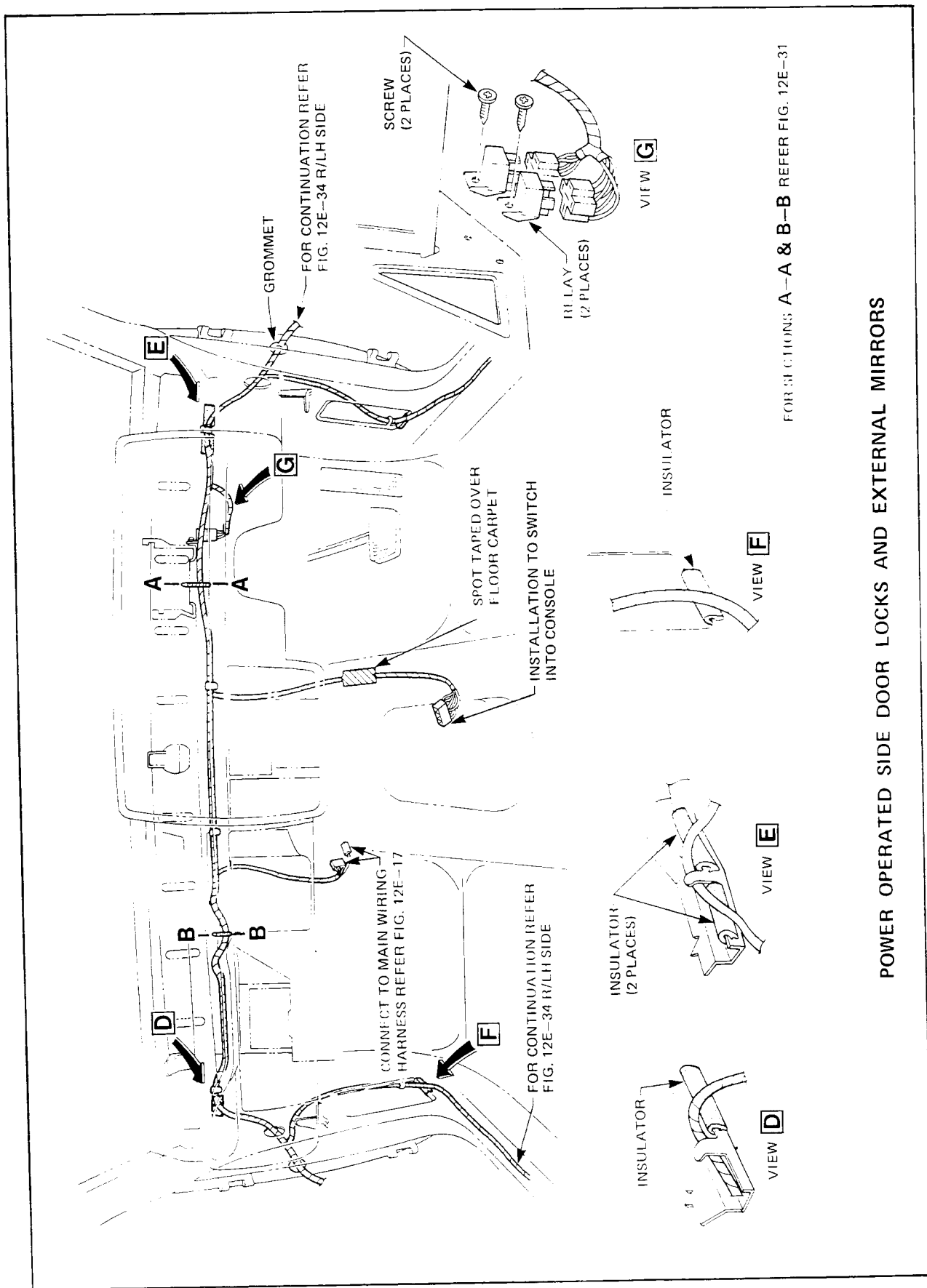

POWER OPERATED SIDE DOOR LOCKS AND EXTERNAL MIRRORS

Figure 12E-33

12E-30 WIRING HARNESS & FUSES

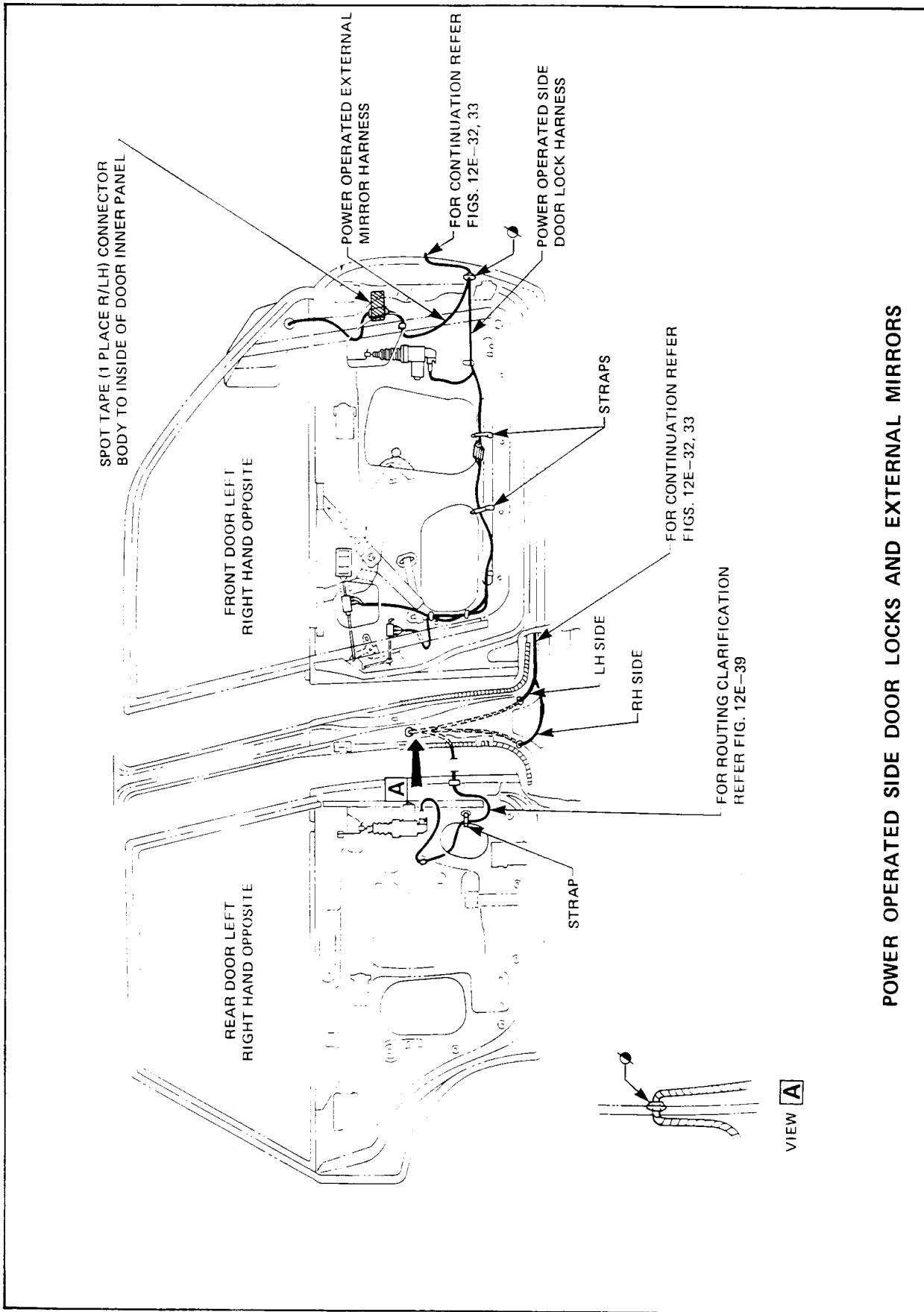
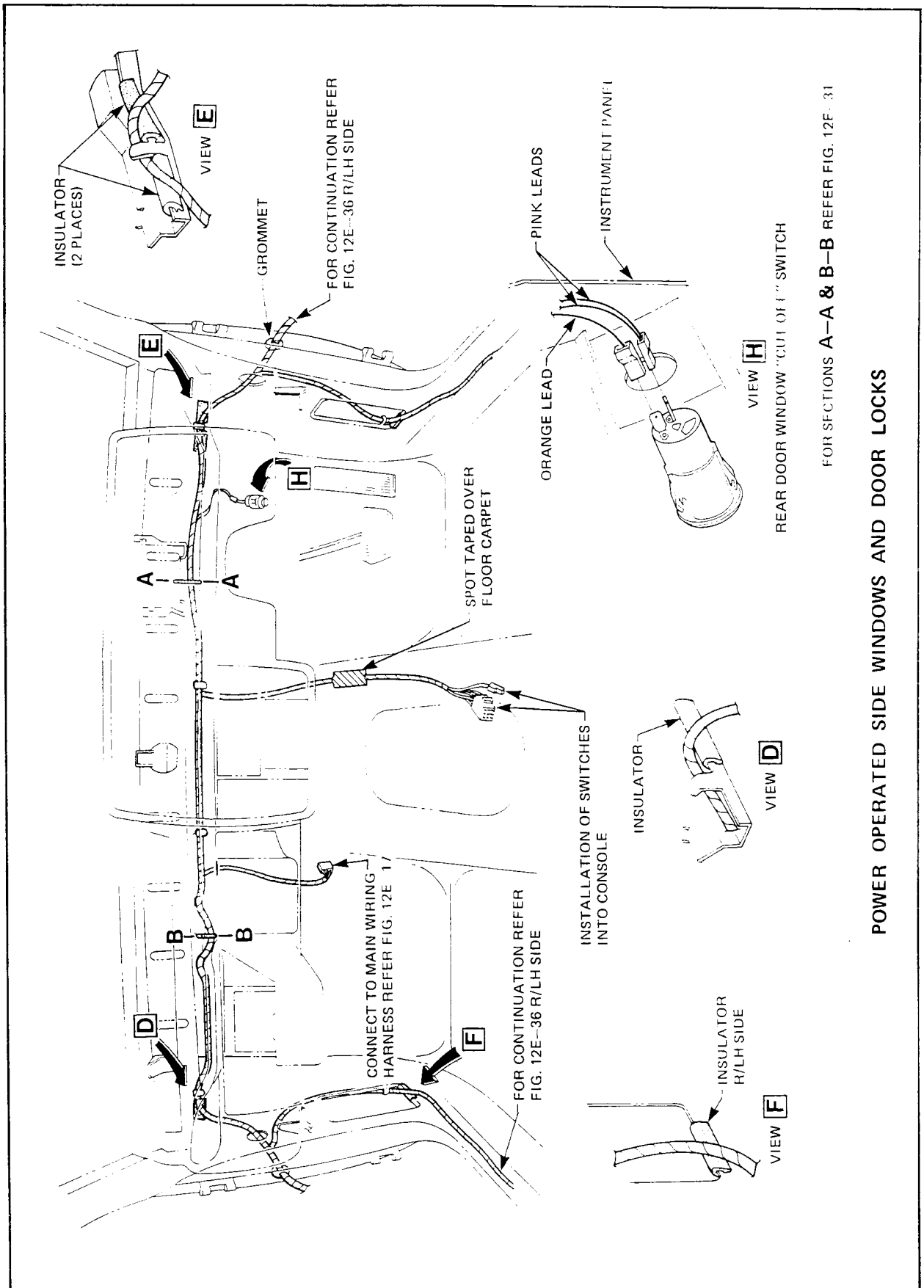

Figure 12E-34

POWER OPERATED SIDE DOOR LOCKS AND EXTERNAL MIRRORS



POWER OPERATED SIDE WINDOWS AND DOOR LOCKS

FOR SECTIONS A-A & B-B REFER FIG. 12E-31

Figure 12E-35

12E-32 WIRING HARNESS & FUSES

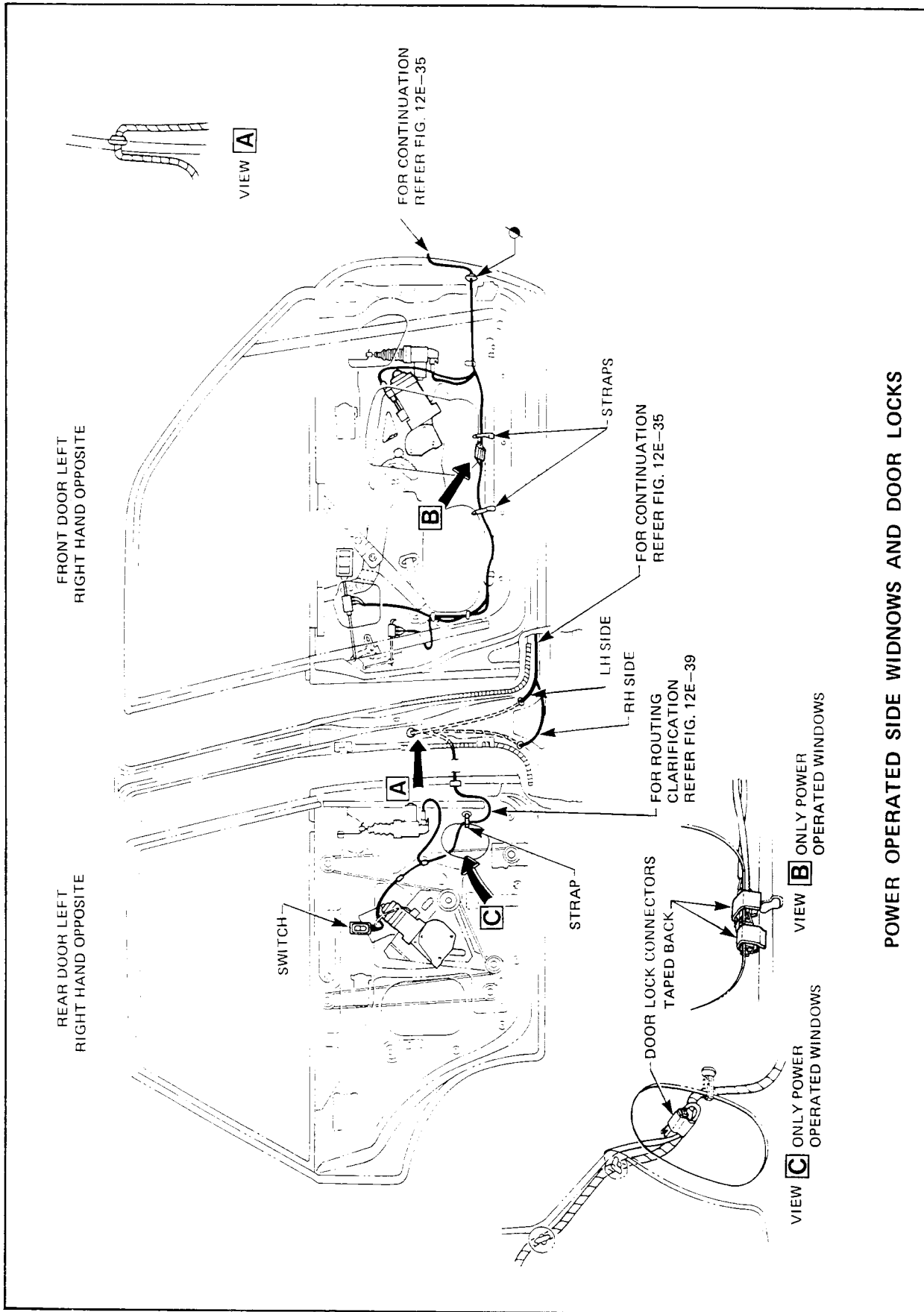

Figure 12E-36

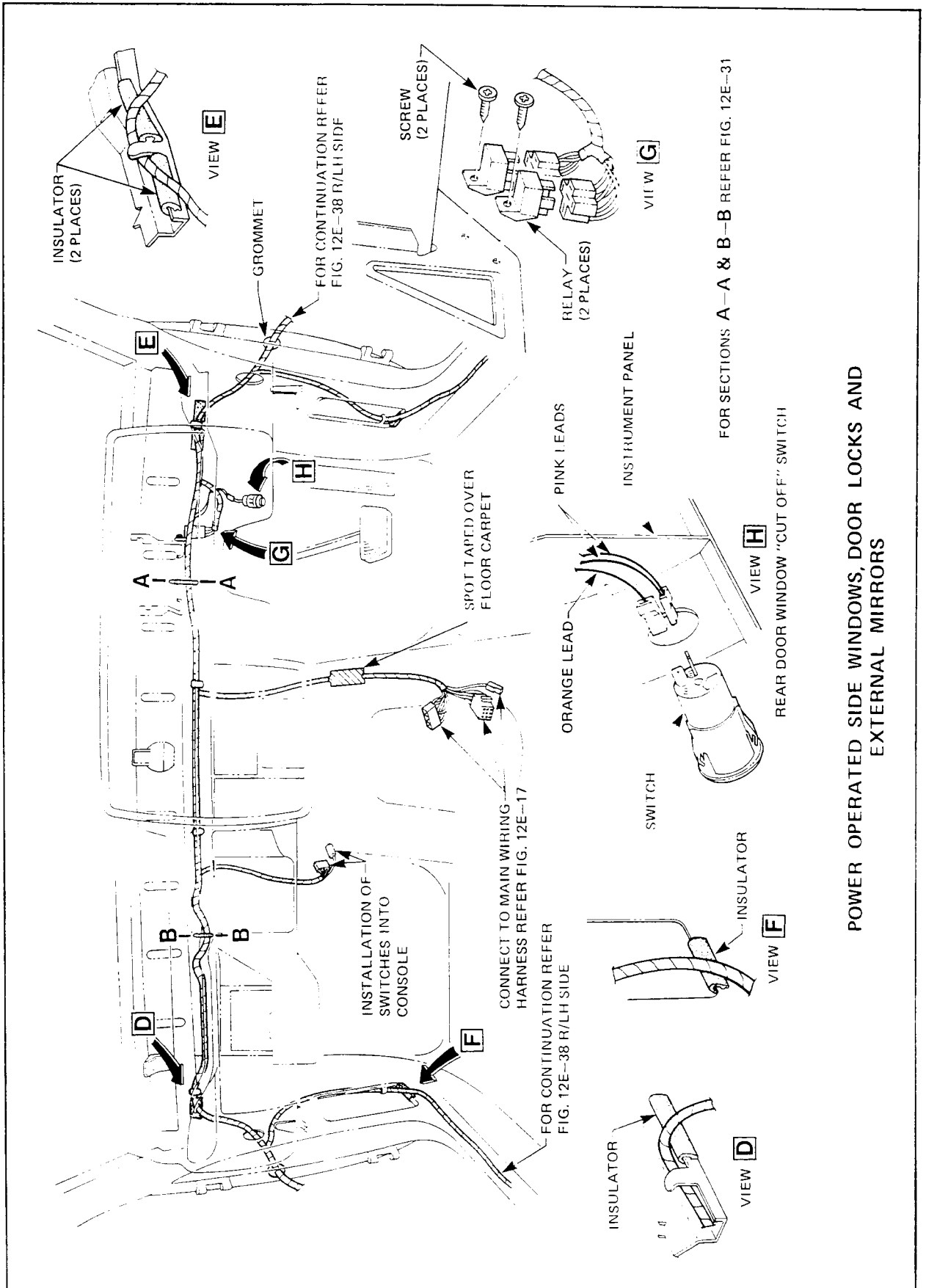
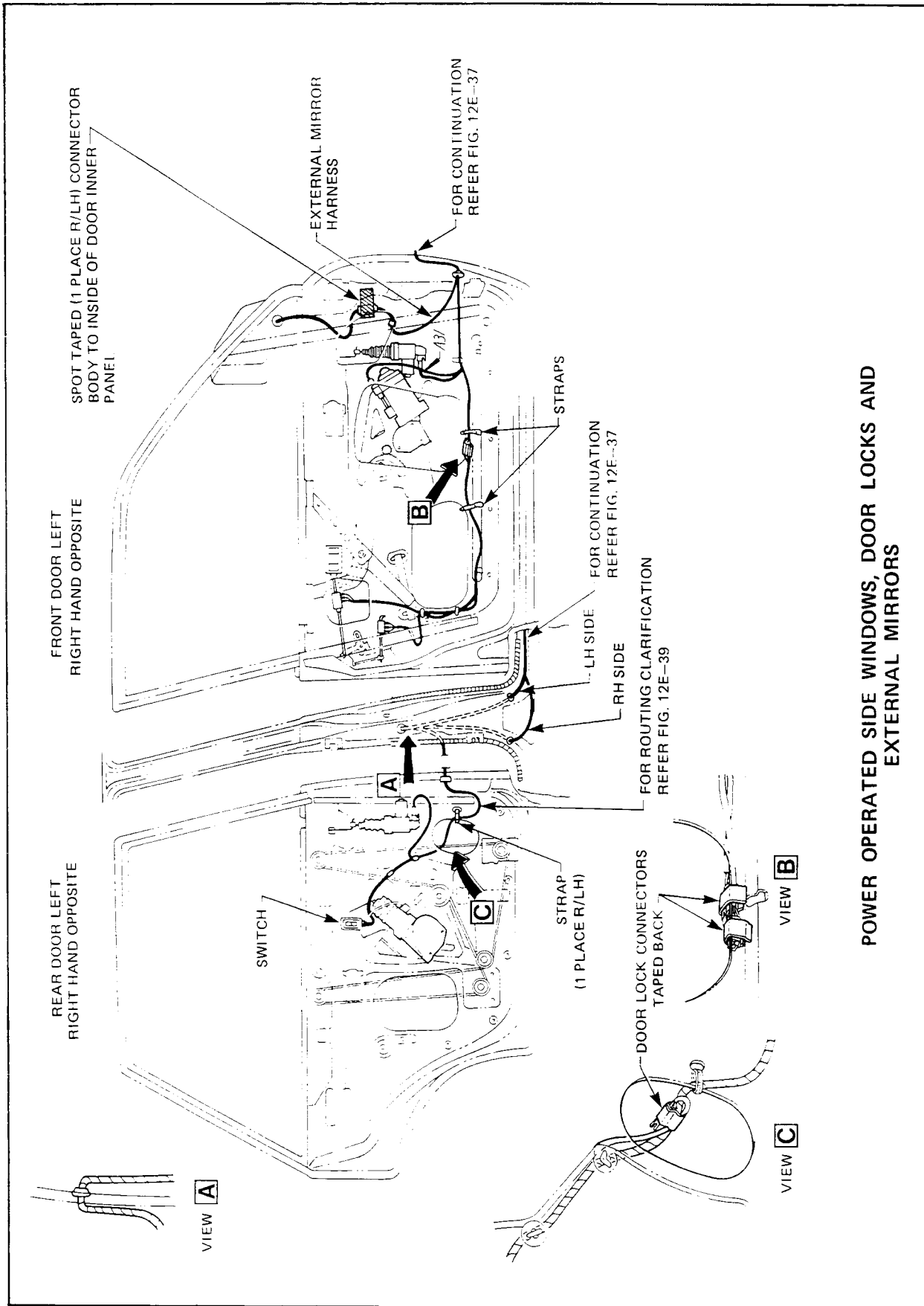

Figure 12E-37

12E-34 WIRING HARNESS & FUSES



POWER OPERATED SIDE WINDOWS, DOOR LOCKS AND
EXTERNAL MIRRORS

Figure 12E-38

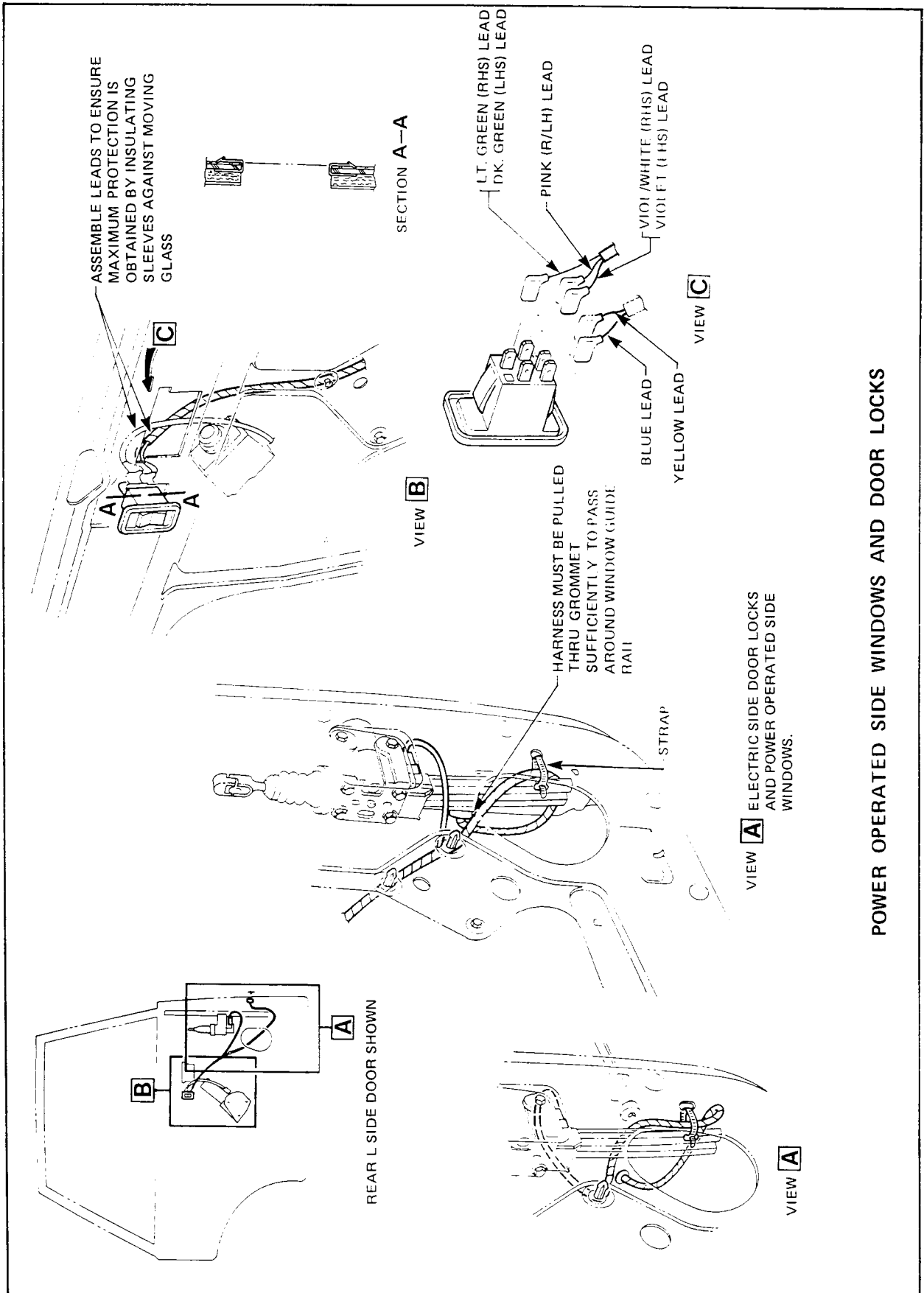

POWER OPERATED SIDE WINDOWS AND DOOR LOCKS

SECTION 12F

WIRING DIAGRAMS

INDEX

Subject	Page
WIRING SCHEMATIC SYMBOLS LEGEND	12F-2
SYMBOLS USED IN VK WIRING CIRCUIT DIAGRAMS.....	12F-4
WIRING SCHEMATIC (PART "A")	12F-5
WIRING SCHEMATIC (PART "B")	12F-6
WIRING SCHEMATIC (PART "C")	12F-7
WIRING SCHEMATIC (PART "D")	12F-8
GENERATOR, BATTERY, STARTER MOTOR AND IGNITION	12F-9
ELECTRONIC FUEL INJECTION SYSTEM	12F-11
5.0 LITRE ENGINE FUEL SYSTEM.....	12F-13
ELECTRONIC SPARK TIMING SYSTEM	12F-15
HEADLAMPS, STOPLAMPS AND HORN.....	12F-17
PARKING LAMPS AND INSTRUMENT PANEL ILLUMINATION	12F-19
INSTRUMENTS - MECHANICAL	12F-21
INSTRUMENTS - ELECTRONIC	12F-23

Subject	Page
CIGAR LIGHTER, TURN SIGNAL AND HAZARD WARNING LAMPS, WIPER WASHER AND DWELL CONTROL	12F-25
HEATED REAR WINDOW AND REAR WINDOW WIPER AND WASHER	12F-27
HEATING AND AIR CONDITIONING	12F-29
RADIO AND POWER ANTENNA.....	12F-31
CLOCK, TRIP COMPUTER, INTERIOR ILLUMINATION, REAR COMPARTMENT LAMP AND LOCK	12F-33
ELECTRIC DOOR LOCKS AND POWER OPERATED SIDE WINDOWS.....	12F-35
ELECTRIC MIRRORS.....	12F-37
FRONT EARTHING CIRCUIT	12F-39
FRONT EARTHING CIRCUIT CONTINUED.....	12F-41
REAR EARTHING CIRCUIT	12F-43
TRIP COMPUTER	12F-45
TRAILER HARNESS.....	12F-47

12F-2 WIRING DIAGRAMS

WIRING SCHEMATIC SYMBOLS LEGEND















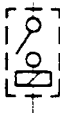











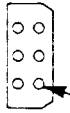

LAMP BULBS				SWITCHES (MANUALLY OPERATED)				INSTRUMENTS			
Code	Name	Max. Amp	Loc.	Code	Name	Max. Amp	Loc.	Code	Name	Max. Amp	Loc.
B 2	L.H. Rear Turn Signal Lamp	1.75	235	S 1	Horn Button	TBA	309	I 1	Generator Indicator	0.10	92
B 3	L.H. Front Turn Signal Lamp	1.75	234	S 2	Auto Retract Ant. Sw. (Touch Control)		292	I 3	Brake Failure Warning Lamp	0.10	92
B 4	R.H. Front Turn Signal Lamp	1.75	239	S 3	Cruise Control Sw.		121	I 4	Park Brake Warning Lamp	0.10	94
B 5	R.H. Rear Turn Signal Lamp	1.75	238	S 4	Cruise Control Speed Restr. Sw.		122	I 7	Voltmeter	0.10	110
B 6	High Beam	5.0	164	S 5	Cruise Control Brake Switch	1.0	119	I 8	Temperature Gauge		102
B 7	Low Beam	4.58	165	S 6	Dome Lamp Switch		134	I 9	Oil Pressure Gauge		107
B 8	Stop Lamp	1.75	313	S 9	Turn Signal Switch		237	I 10	Fuel Gauge		105
B 9	Instr. Compartment Box Illum.	0.42	129	S 13	Heated Rear Window Switch (Manual)	20.0	142/ 149	I 11	Tachometer	0.20	111
B 10	Dome Lamp	0.83	134	S 11	Electric Door Lock Switch (Key) L.H.		324	I 12	L.H. Turn Signal Indicator	0.10	236
B 12	Automatic Trans. Ind. Illum.	0.1	172	S 15	Dwell Control Switch		215	I 13	R.H. Turn Signal Indicator	0.10	237
B 13	Instrument Cluster Illum. Lamp	0.1	172	S 17	Hazard Warning Sw.		237	I 14	High Beam Indicator	0.28	163
B 14	Dwell Control Switch Illum.	0.1	172	S 20	Air Conditioner Master Switch		249/ 274	I 15	Oil Pressure Warning Lamp	0.10	96
B 15	Front Parking Lamps	0.41	169	S 21	Air Conditioner Fan Switch	15.0	264/ 276	I 20	Coolant Level Warning Lamp		117
B 16	Tail Lamps	0.42	169	S 22	Dimmer & Flasher Sw.		164	I 23	Electronic Speedo		127
B 17	Rear Licence Plate Illum.	0.83	169	S 23	Windshield Wiper Sw.		223	I 25	Trip Computer Display Module		160
B 21	Rear Window Wiper Washer Switch Illum.	0.1	172	S 26	Light Switch		169	I 26	Trip Computer Function Indicator		160
B 22	Rear Quarter Lamp	0.42/1.0	132	S 29	Power Operated Side Window Switch		341/ 344	I 28	Electronic Spark Timing Lamp	0.10	76
B 23	Rear Comp. Lamp	0.83	136	S 30	Electric Door Locks Switch (Button)		327	I 29	S13 Indicator Lamp (Touch Control)	0.10	142
B 24	Heat/Air Cond. Contr. Illum.	0.05	172	S 32	Rear Compartment Lock Switch		138	I 36	Back-Up Lamps Warning Lamp	0.10	114
B 25	Radio Illum.	0.1	172	S 34	Ignition Switch		13	I 37	Exterior Illum. Warning Lamp	0.10	169
B 26	Light Switch Illum.	0.1	172	S 35	Windshield Wash. Sw.		227	ELECTRONIC MODULES			
B 28	Cigar Lighter Illum.	0.1	172	S 37	Rear Window Wiper Sw. (Touch Control)		208				
B 29	Back-Up Lamps	1.75	114	S 38	Rear Window Washer Sw. (Touch Control)	0.7	209	N 1	Dwell Control Unit		215
B 30	Heated Rear Window Switch Illum.	0.1	172	S 40	Power Operated Side Window Sw. (O/ride)		337	N 3	Power Antenna Control Unit		291
B 31	Clock Illum. Lamp	0.1	172	S 45	Power Operated Side Window Sw. (4 way)		343	N 6	Coolant Level Warning Module		117
B 32	Engine Compartment Illum. Lamp	0.83	169	S 53	Electric Mirror Adjustment Sw.	0.7	183	N 10	Electronic Contact Breaker		64
B 33	Power Antenna Switch Illum.	0.1	172	S 13	Heated Rear Window Sw. (Touch Control)	20.0	142	N 12	Radio Receiver		300
B 48	Trip Computer Controls Illum.	0.10	172	S 36	Rear Window Wiper Washer Sw. (Manual)		194	N 19	Clock Digital		152
TRAILER				S 14	Heater Fan Switch		264	N 21	E.S.T. Control Module (Manual)		76
				SOUND PRODUCING DEVICES				N 21	E.S.T. Control Module (Automatic)		76
B102	L.H. Rear T/S LP.	2.1	233	H 1	Horn	3.0	311	N 22	Trip Computer Master Module		157
B105	R.H. Rear T/S LP.	0.6	240	H 2	Radio Speaker Front R.H. or Centre		304	N 26	Voltage Stabilizer		102
B108	Stop Lamp	0.5	313	H 3	Radio Speaker Front L.H.		304	N 28	E.F.I. Control Module		44
B116	Tail Lamp	2.1	169	H 4	Radio Speaker Rear R.H.		304	N 29	Fuel Pump Module		36
B117	Rear Lic. Plate Illum.	0.42	169	H 5	Radio Speaker Rear L.H.		304	N 30	Air Conditioner System Module		256
B129	Back-Up Lamp	0.83	114	H 6				N 31	Heated Rear Window Module		143
POWER SUPPLY											
P 1	Battery 6 Cyl. 8 Cyl.	160A 253A	1 1								
P 2	Generator 45 amp 55 amp 70 amp 60 amp		7 7 7 7								

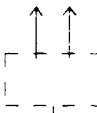
WIRING DIAGRAMS 12F-3

SENSORS				MOTORS				RELAYS, SOLENOIDS			
Code	Name	Max. Amp	Loc.	Code	Name	Max. Amp	Loc.	Code	Name	Max. Amp	Loc.
SS 1	Brake Fail Warn. Sw.		91	M 2	Antenna Motor	2.0/9.0	291	R 1	Horn Relay	20.0	311
SS 2	Park Brake Warn Sw.		94	M 5	Tape Player		300	R 3	Anti-Dieseling Solenoid	0.5	28
SS 4	Cold Feed Switch		30	M 6	Heater Blower Mtr.	15.0	262	R 4	Distributor Vacuum Advance Solenoid		30
SS 5	T.C.S. Switch		30	M 8	Windshield Wiper Motor (De color)	5.0	224	R 5	Transmission Detent Solenoid	1.10	200
SS 7	Oil Pressure Switch		96	M 9	Washer Pump Motor (Windshield)	2.9	227	R 6	Flasher Relay		235
SS 8	Neutral Start Sw.		17	M 10	Electric Fuel Pump Motor		37	R 7	Air Conditioner Compressor Clutch		255/281
SS 9	Back-Up Switch		114	M 11	Air Conditioner Fan Motor	16.6	251/276	R 8	Air Conditioner Fan Relay	0.2/30.0	270/245
SS10	Stop Lamps Sw.		313	M 12	Air Conditioner Aux. Fan Motor	6.8	259/284	R 10	Air Conditioner Aux. Fan Relay	0.2/30.0	258/284
SS11	Air Cond. Aux. Fan Temp. Switch		283	M 13	Power Operated Side Window Motor		342	R 11	Power Operated Window Relay	0.2/30.0	347
SS13	Air Cond. Evap. Inlet Contr. Sw.		255/281	M 16	Elect. Door Lock Motor Front R.H.	8.0	323	R 12	Starter Mtr. Solenoid		13
SS16	Coolant Level Warning Sensor		117	M 17	Elect. Door Lock Motor Front L.H.	8.0	323	R 14	Rear Compartment Lock Solenoid	14.0	138
SS19	Transmission Detent Switch		200	M 18	Starter Motor 8 Cyl.		72	R 16	Hazard Flasher Relay		237
SS20	Door Jamb Switch		134	M 20	Rear Window Wiper Motor	3.5/20.0	197/205	R 17	Electric Door Locks Relay	0.15/30.0	330/322
SS23	Engine Revolutions Sensor		64/76	M 21	Rear Window Washer Pump Motor	3.8	194/208	R 27	Heated Rear Window Relay	0.2/30.0	149
SS26	Trip Comp. Vehicle Speed Sensor		161	M 22	Elect. Door Lock Motor Rear R.H.	8.0	324	R 28	Eng. Idle Speed Boost Solenoid (6 Cyl.)	0.45	256/281
SS27	Trip Computer Fuel Flow Sensor		157	M 25	Elect. Door Lock Motor Rear L.H.	8.0	324	R 30	Cruise Control Transducer Solenoid	0.3/2.2	121
SS26	Elect. Speedometer Speed Sensor		126/161	M 26	Elect. Mirror Motor R.H. Vertical		189	R 38	Injector Valve	0.80	43
SS29	Rear Compartment Lamp Switch		136	M 28	Elect. Mirror Motor R.H. Horizontal		186	F 53	Elect. Mirrors Select. Relay R.H.	0.15/30.0	186
SS30	Instr. Compt. Box Illum. Switch		129	M 29	Elect. Mirror Motor L.H. Vertical		179	R 53	Elect. Mirrors Select. Relay L.H.	0.15/30.0	181
SS33	Throttle Valve Switch (E.S.T.)		82	M 30	Elect Mirror Motor L.H. Horizontal		182	R 55	Air Cond. Fan Relay Negative	0.2/30.0	247/272
SS35	E.F.I. Air Flow Sensor		55	M 8	Windshield Wiper Motor (Lucas)	5.0	224	CIRCUIT PROTECTION DEVICES			
SS36	Throttle Valve Switch (E.F.I.)		42	M 8	Windshield Wiper Motor (Preslite)	5.0	224	1	Fuse	15	165
SS37	Camshaft Position Sensor		22	RESISTORS, RHEOSTATS				2	Fuse	15	164
SS43	Distributor High Tension Sw. (6 Cyl.)		61	E 1	Heated Rear Window		145/150	3	Fuse	15	169
SS44	Wiper Motor Parking Switch		222	E 2	Instr. Illum. Rheostat	45w	172	4	Fuse	7.5	37
SS46	Carb. Vac Sensor		83	E 3	Air Conditioner Fan Resistors		250/276	5	Fuse	25	244
CAPACITORS				E 4	Cigar Lighter		242	6	Fuse	15	313
C 2	Radio Interference Supp. (Generator)	0.5 MF	10	E 5	Oil Pressure Sender		108	7	Fuse	15	145
C 3	Primary Voltage Capacitor		24	E 6	Coolant Temperature Sender (8 & 6 Cyl.)		103	8	Fuse	15	237
RECTIFIERS				E 7	Fuel Level Sender Sedan Wagon		105/105	9	Fuse	15	136
D 5	Air Cond. Clutch Protect. Diode		282	E 9	Ballast Resistor	1.8	22	10	Fuse	15	32
D 3	Elect. Instruments Display	5.0	98	E 11	Transistor Load Resistor		101	11	Fuse	15	207
MISCELLANEOUS ITEMS				E 13	Cruise Control Transd. Resist.	40	121	12	Fuse	15	125
X 1	Distributor EST, E.F.I., B.C.		63, 63, 63	E 6	Coolant Temp. Sensor (EST & EFI)		47/78	13	Fuse	15	226
X 3	Spark Plug 8 Cyl., 6 Cyl.		61, 61	E 15	Auxiliary Air Valve		49	14	Fuse	3/7.5	299
X 4	Connection for Test.		81					15	Fuse	15	262
								G	P.O Side Windows	25	346
								J	Fusible Link	TBA	1
								P	Antenna Motor Fuse	6	291
								R	Fusible Link (E.F.I.)	TBA	31
								TRANSFORMERS			
								G 1	Ign. Coil (6 & 8 Cyl.)	7.5	62

12F-4 WIRING DIAGRAMS

SYMBOLS USED IN VK WIRING CIRCUIT DIAGRAMS

	FIXED CONTACT		LIGHT BULB
	FIXED CONTACT (UNDER POWER)		SPEAKER
	FIXED CONTACT (UNDER POWER THRU RESISTANCE)		HORN
	MOVABLE CONTACT		RELAY
	SIMULTANEOUSLY MOVABLE CONTACTS		RHEOSTAT
	FUSE		LOCATION OPTIONAL
	FUSIBLE LINK		LOCATION FIXED BY RESISTANCE
	SPARK PLUG		CONNECTOR BODY WITH FEMALE TYPE TERMINALS
	SWITCH		CONNECTOR BODY WITH MALE TYPE TERMINALS
	MAGNETIC SENSOR		SIMPLIFIED VIEW OF A CONNECTOR BODY RED = LOCATION & COLOUR OF LEAD
	DIODE		SIMPLIFIED VIEW OF AN ELECTRICAL COMPONENT (WITH 2 MALE TERMINALS)
	RESISTOR		EARTH FROM COMPONENT TO VEHICLE BODY
	SOLENOID		EARTH THROUGH EARTHING LEAD TO VEHICLE
	MAGNETIC INSTRUMENT		
	THERMAL INSTRUMENT		
	ELECTRONIC MODULE		
	ELECTRIC MOTOR		

ALL SWITCHES SHOWN IN "OFF" POSITION

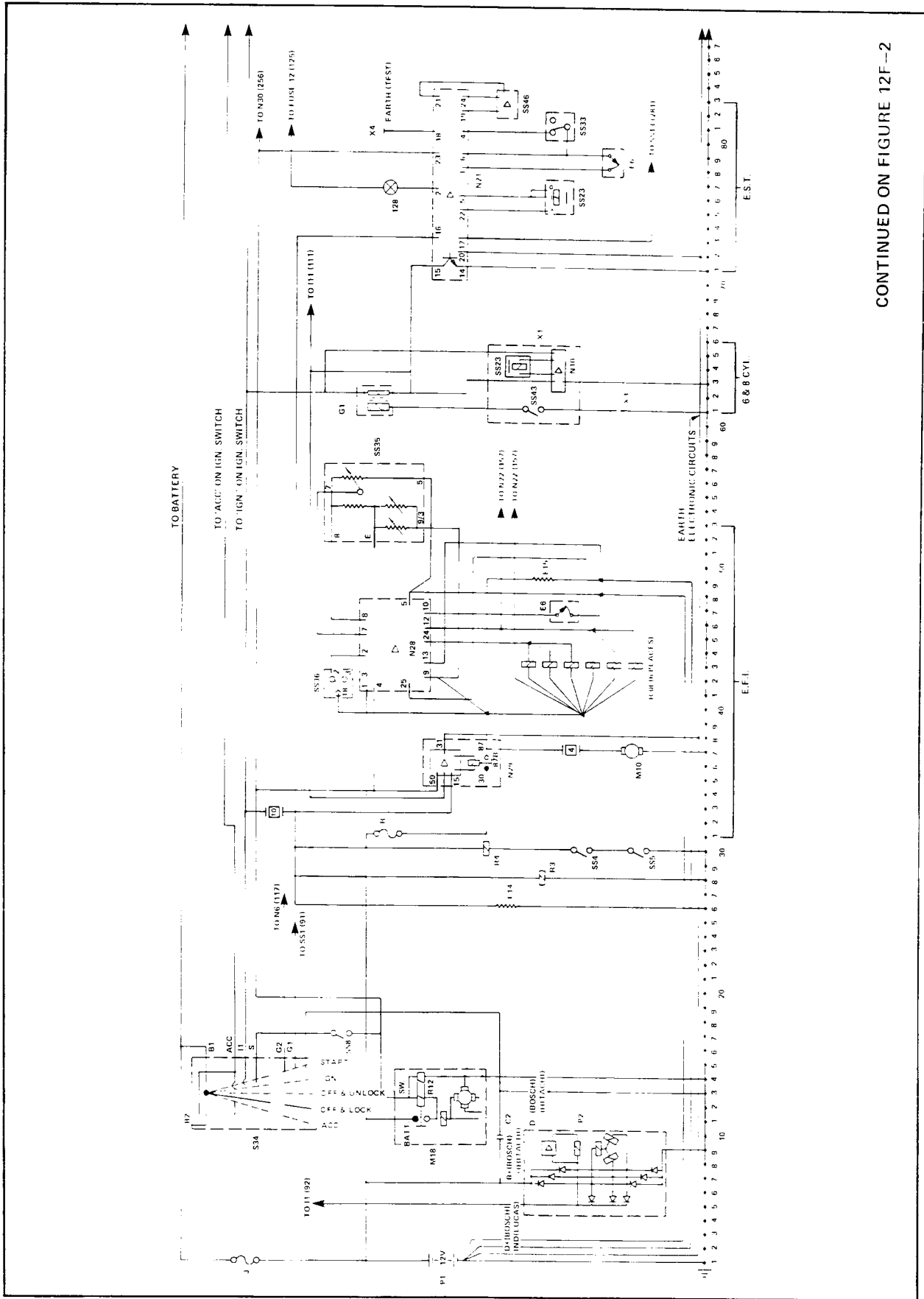

CONTINUED ON FIGURE 12F-2

Figure 12F-1 Wiring Schematic (Part A)

12F-6 WIRING DIAGRAMS

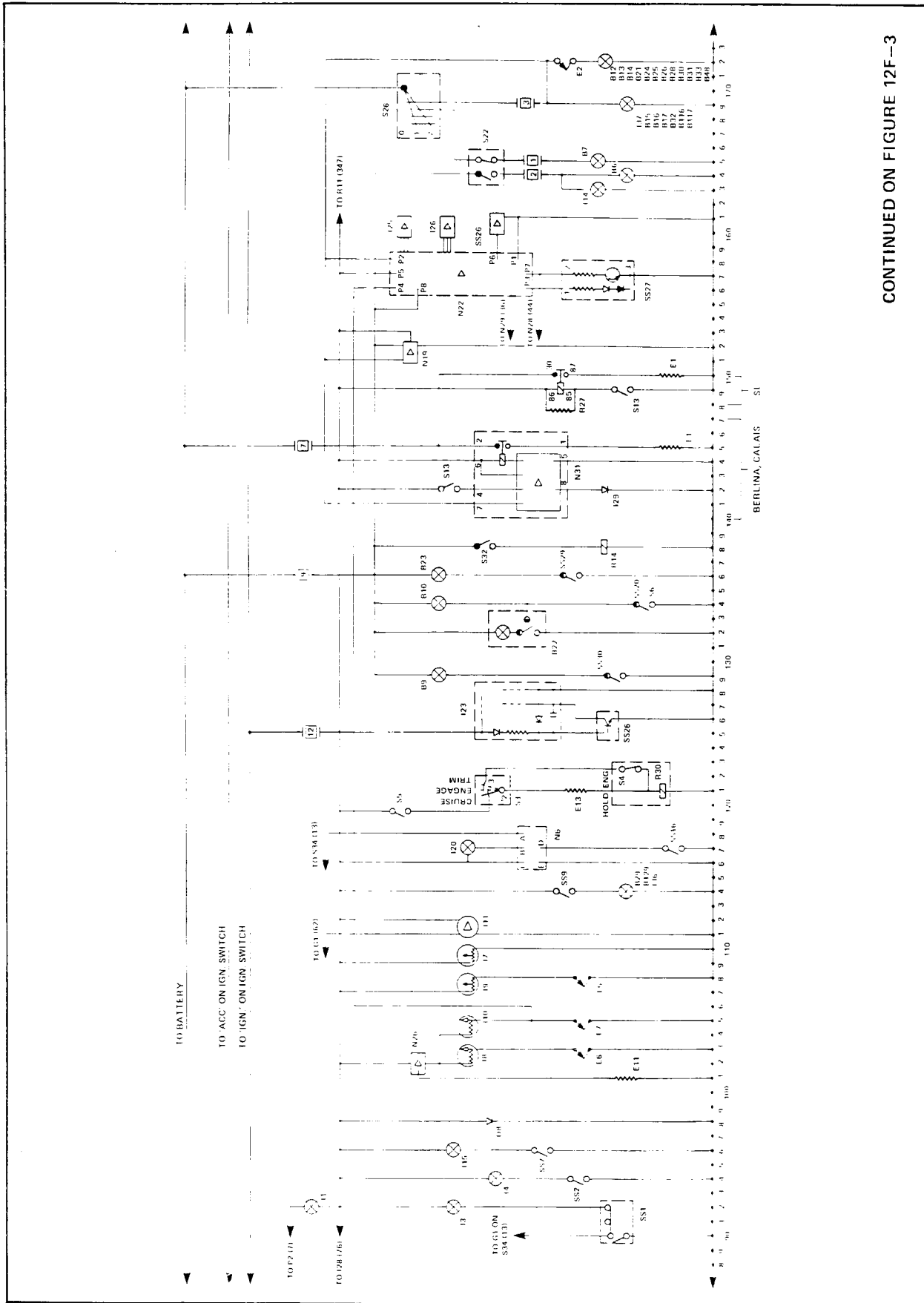

CONTINUED ON FIGURE 12F-3

Figure 12F-2 Wiring Schematic (Part 'B')

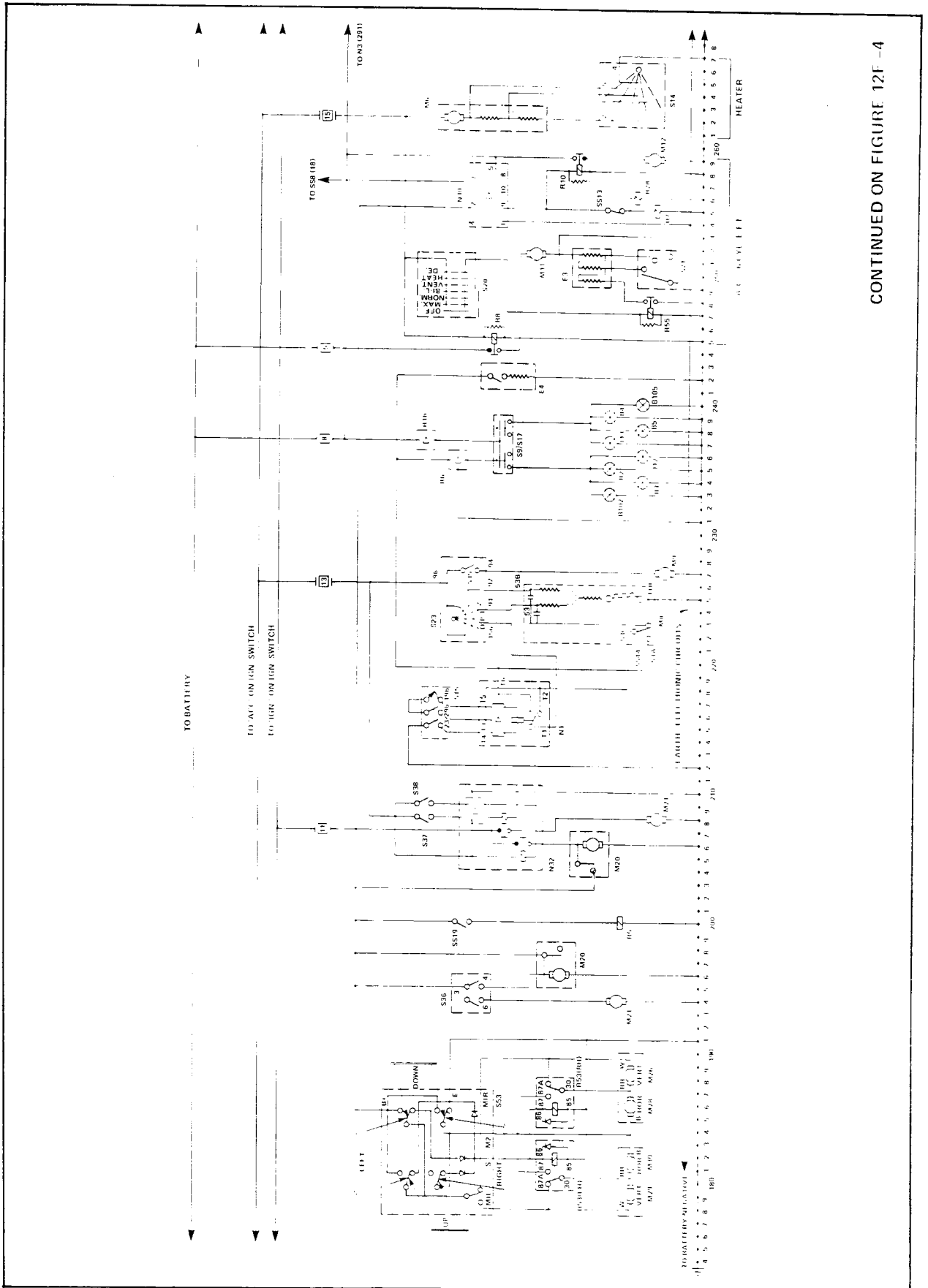

CONTINUED ON FIGURE 12F-4

Figure 12F-3 Wiring Schematic (Part 'C')

12F-8 WIRING DIAGRAMS

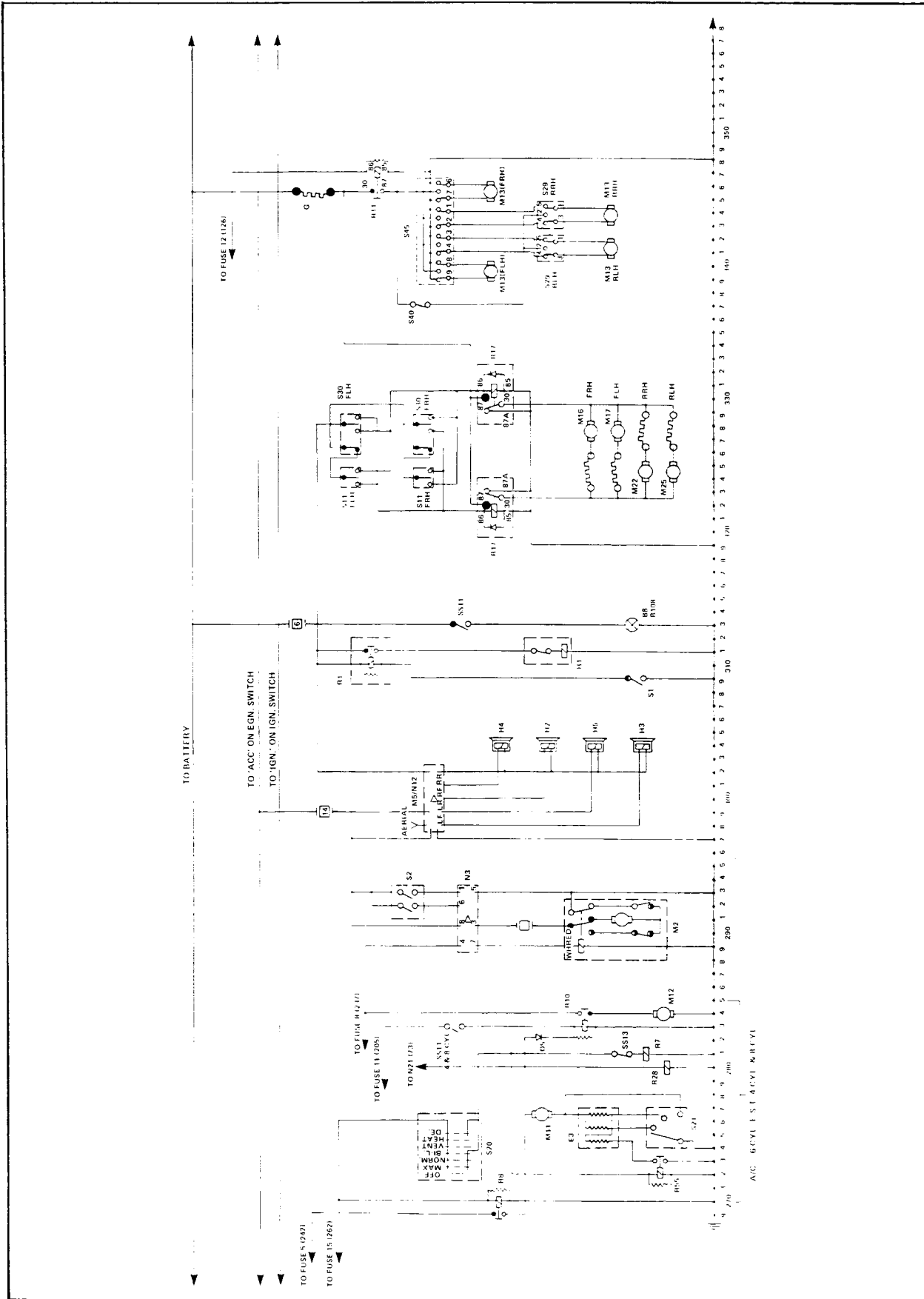

Figure 12F-4 Wiring Schematic (Part 'D')

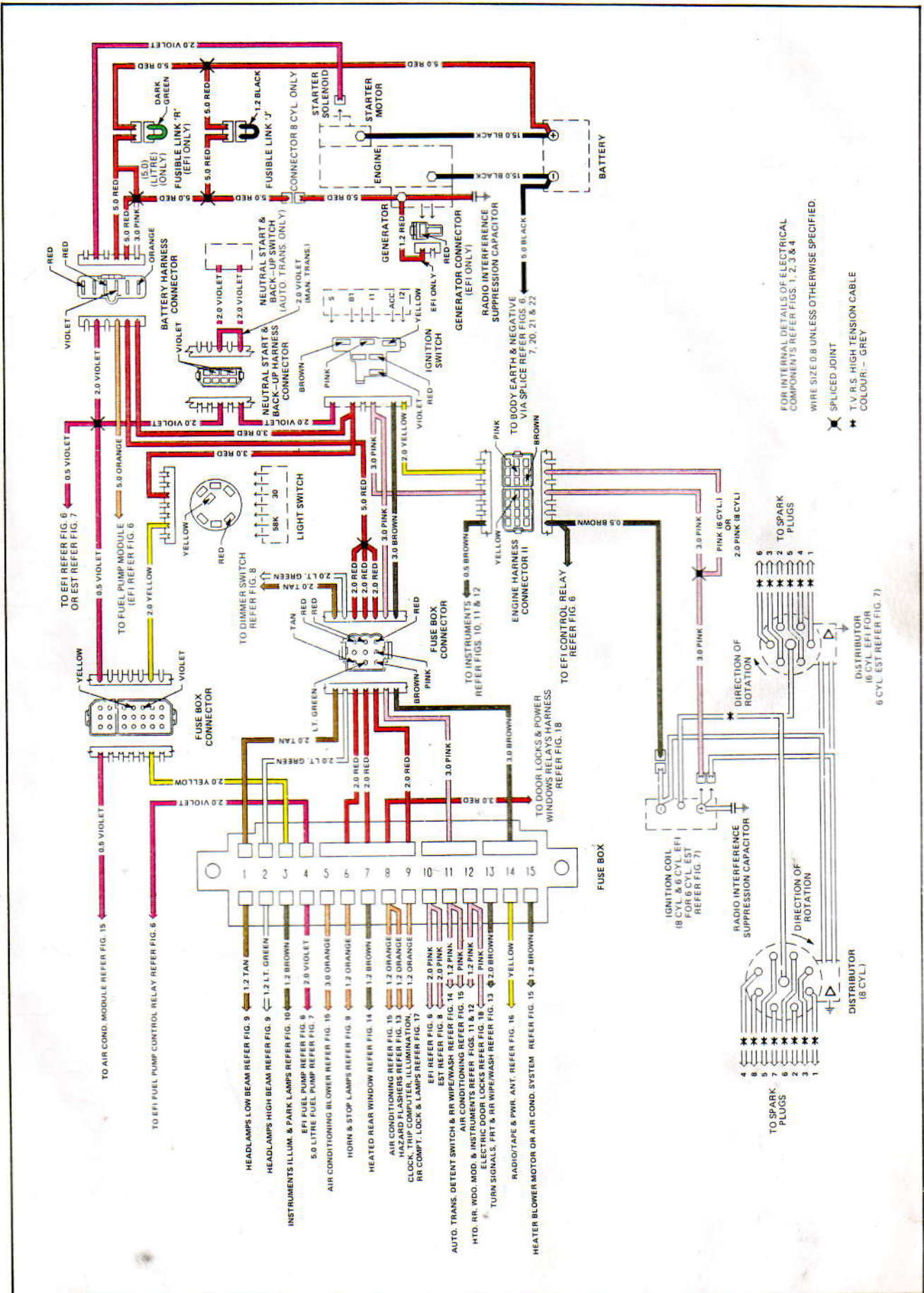

Figure 12F-5 Generator, Battery, Starter Motor and Ignition

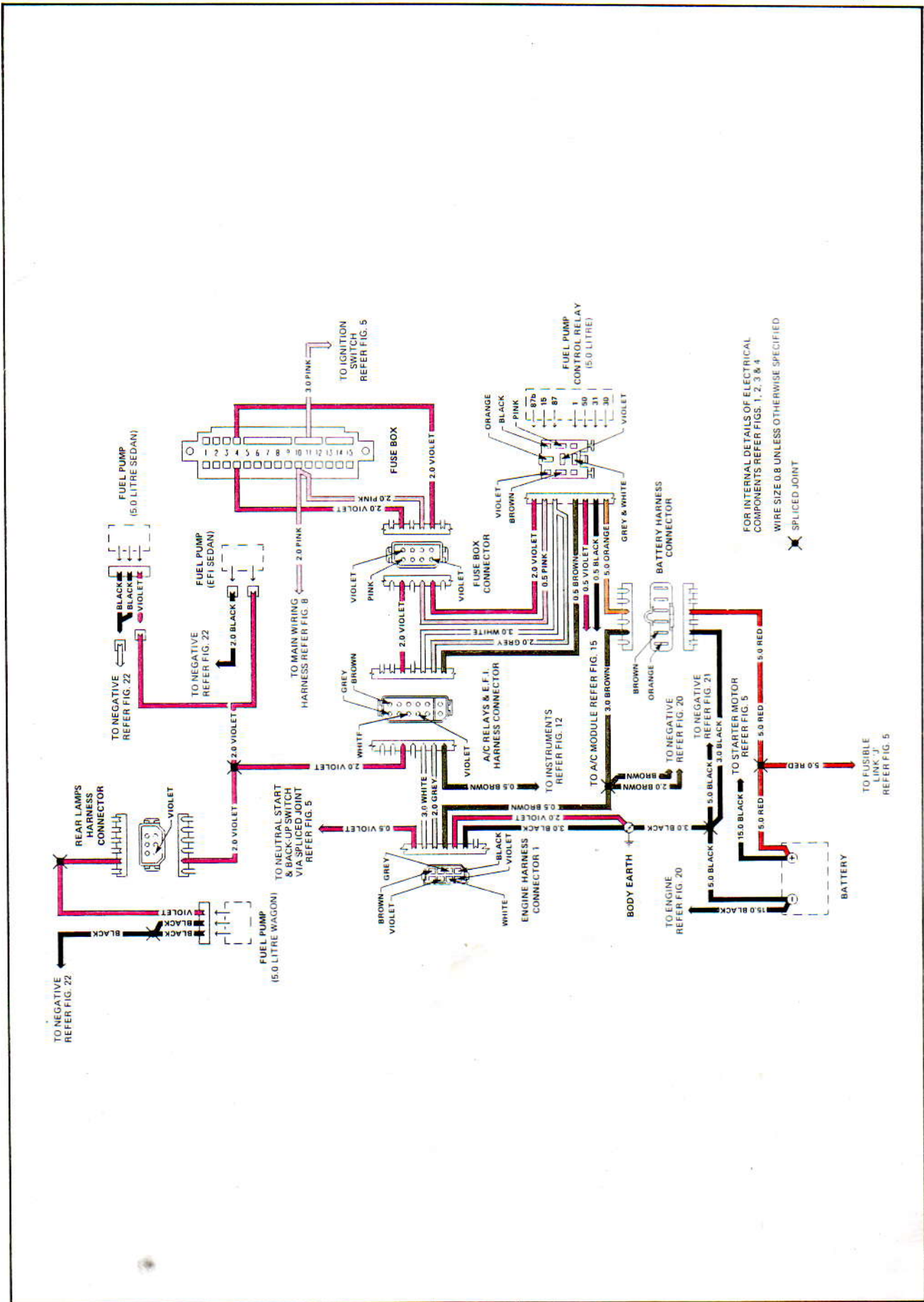

Figure 12F-7 5.0 Litre Engine Fuel System

WIRING DIAGRAMS 12F-15

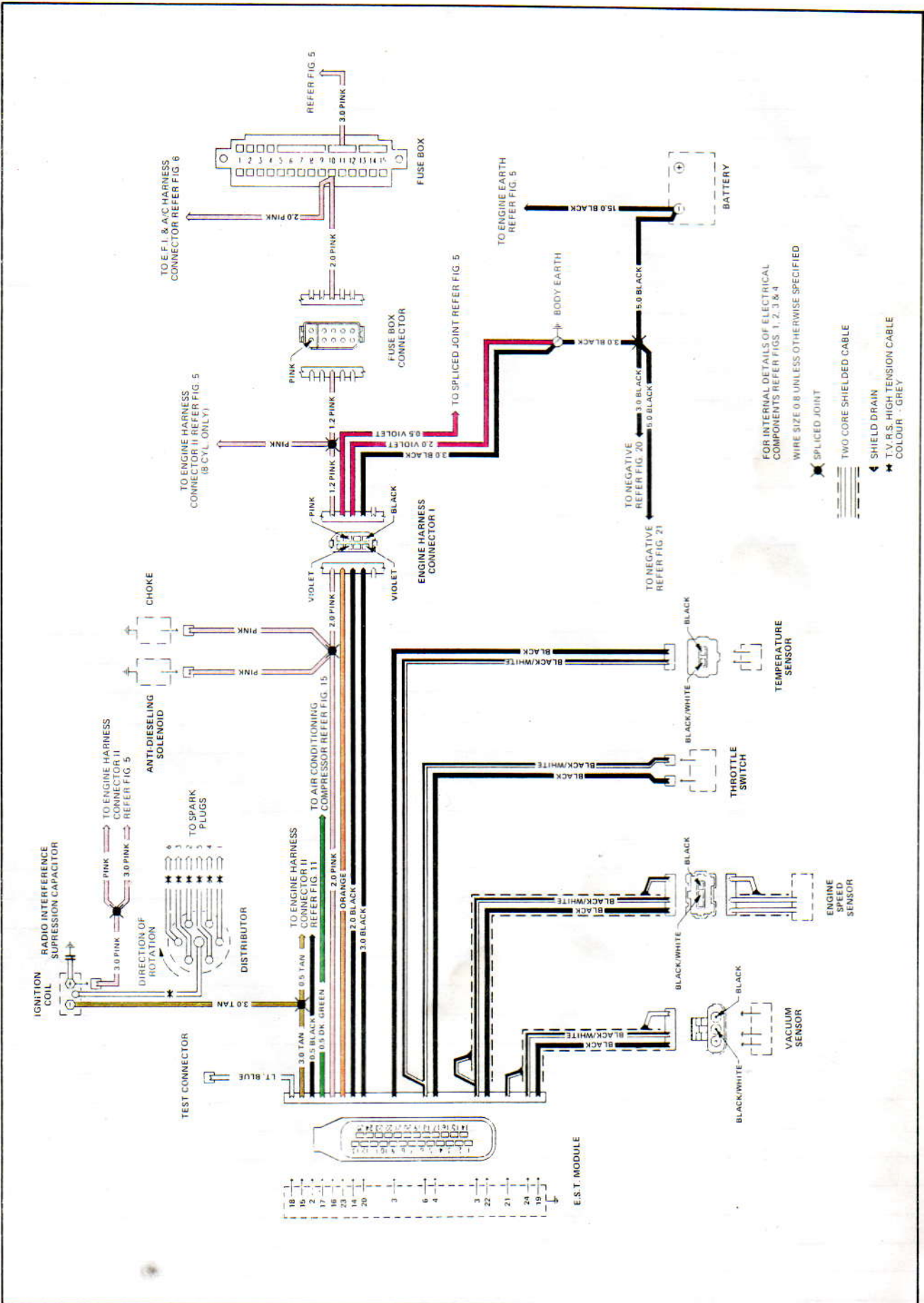

Figure 12F-8 Electronic Spark Timing System

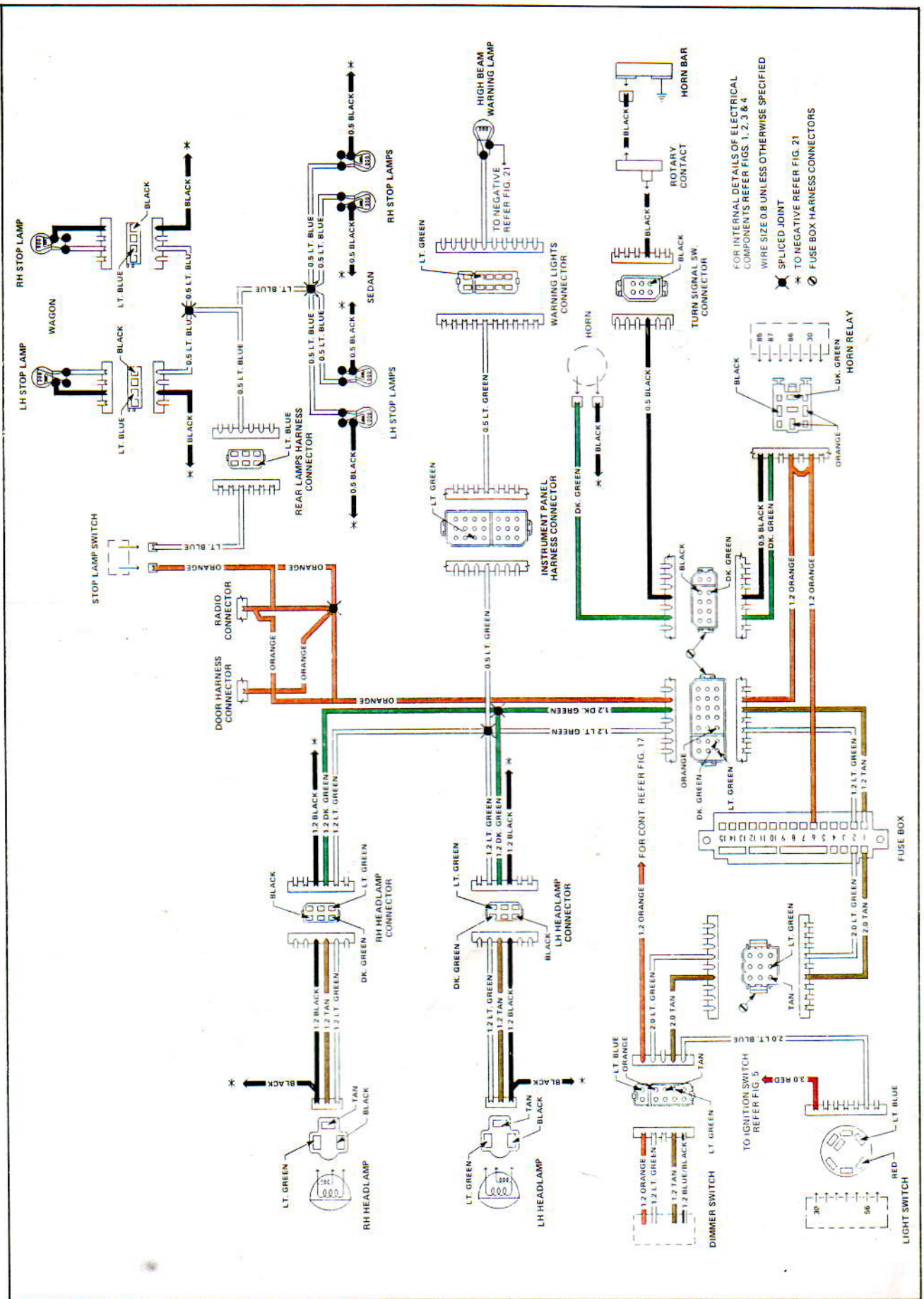

Figure 12F-9 Headlamps, Stoplamps and Horn

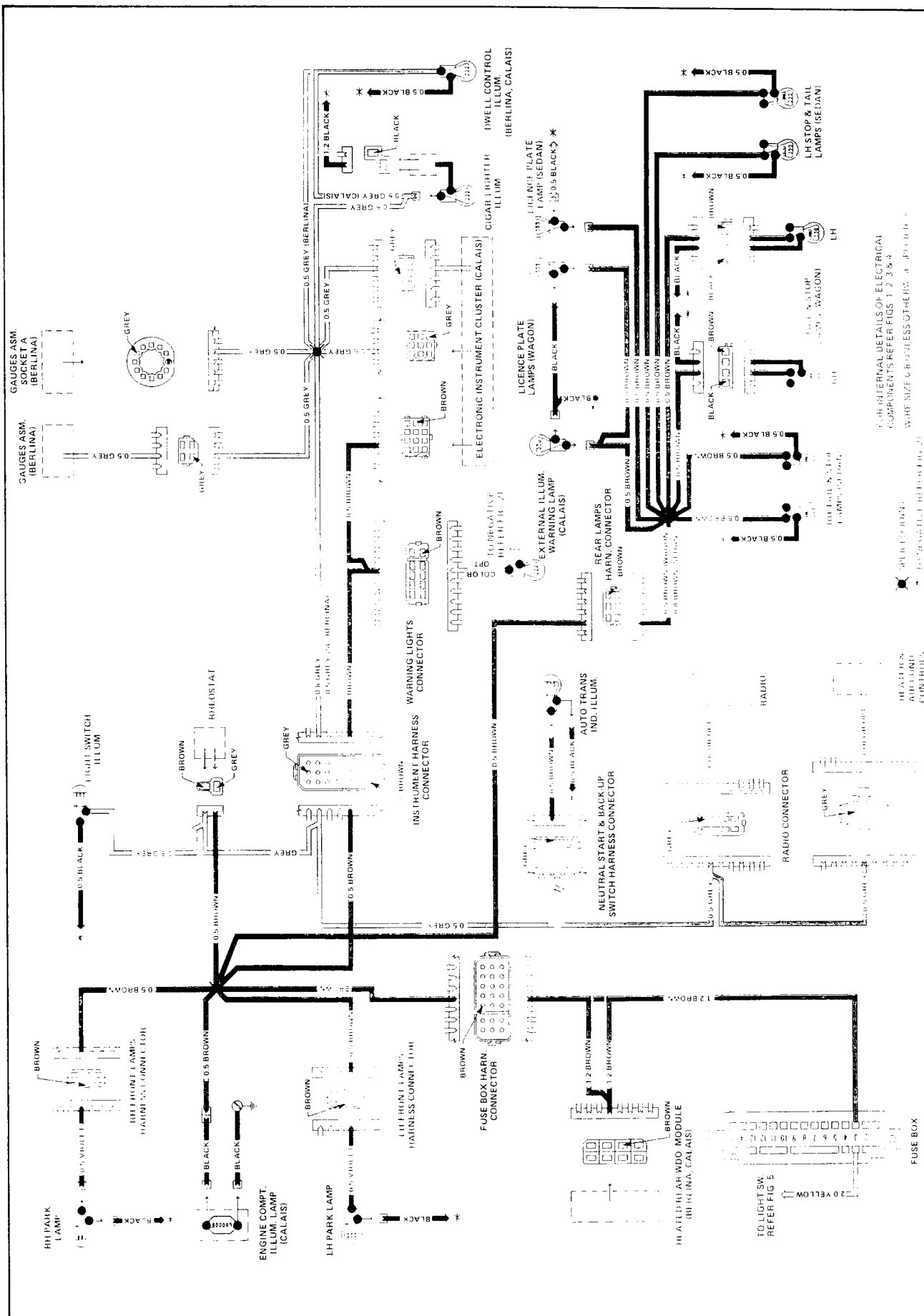

Figure 12F-10 Parking Lamps and Instrument Panel Illumination

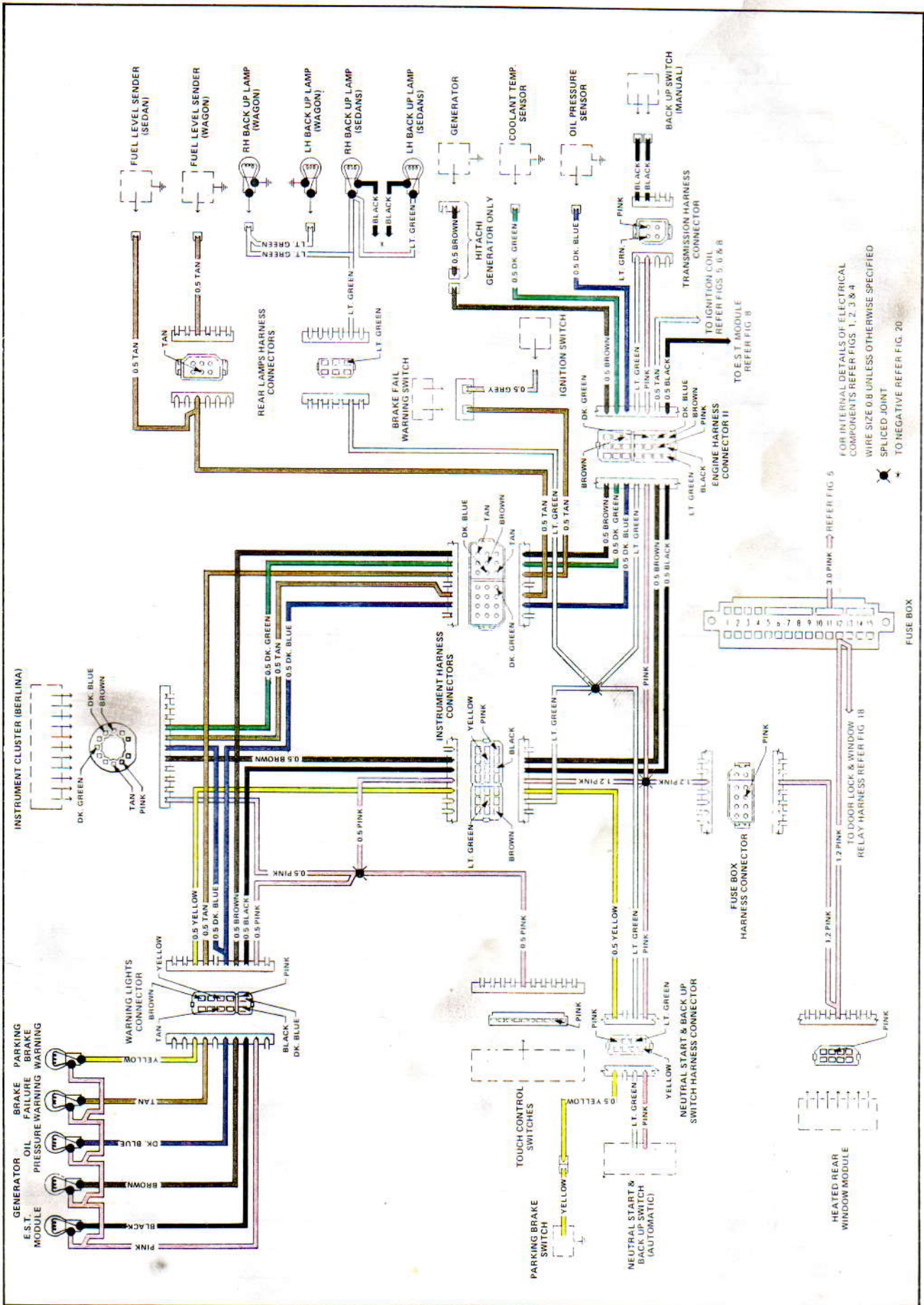

Figure 12F-11 Instruments - Mechanical

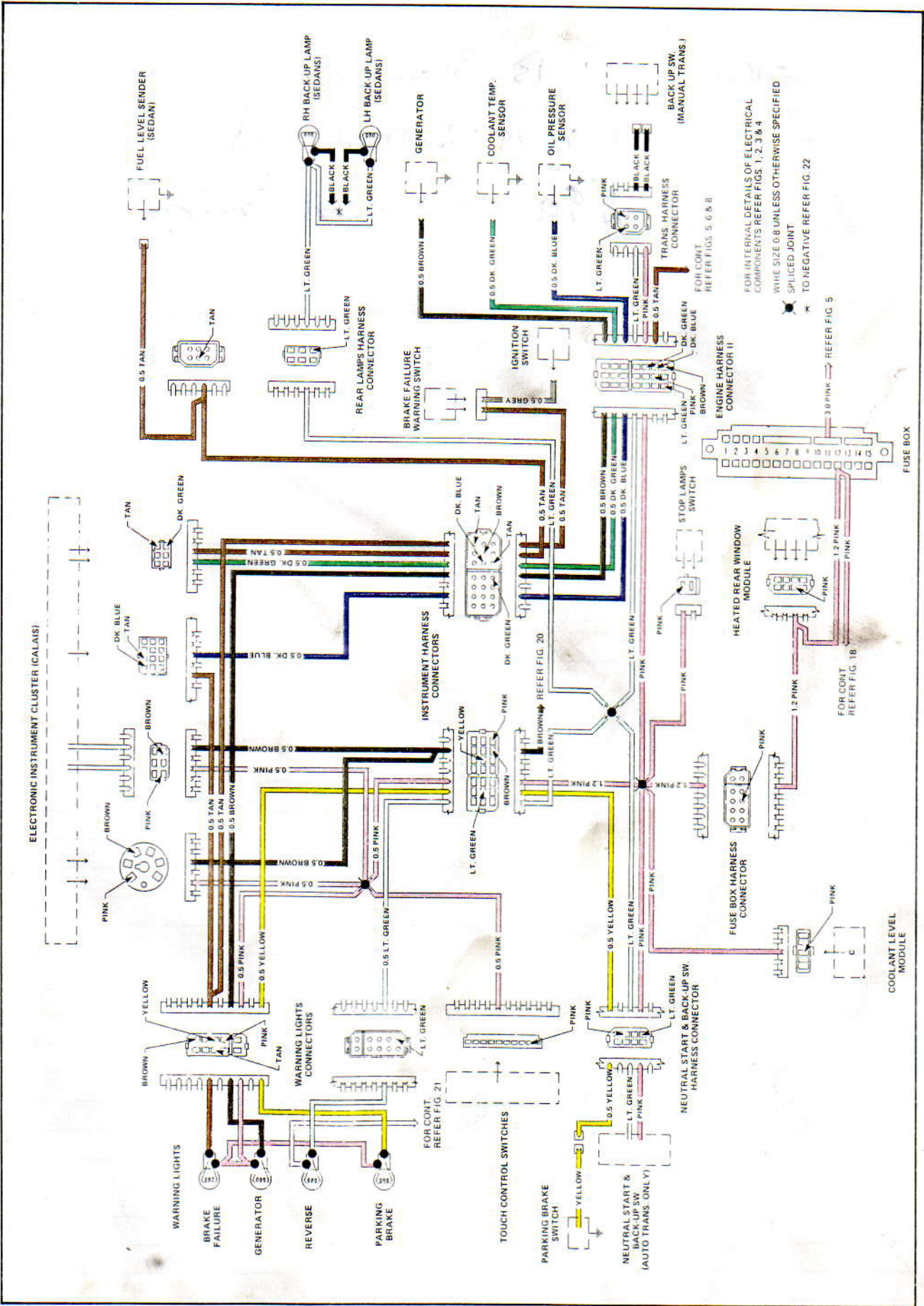

Figure 12F-12 Instruments - Electronic

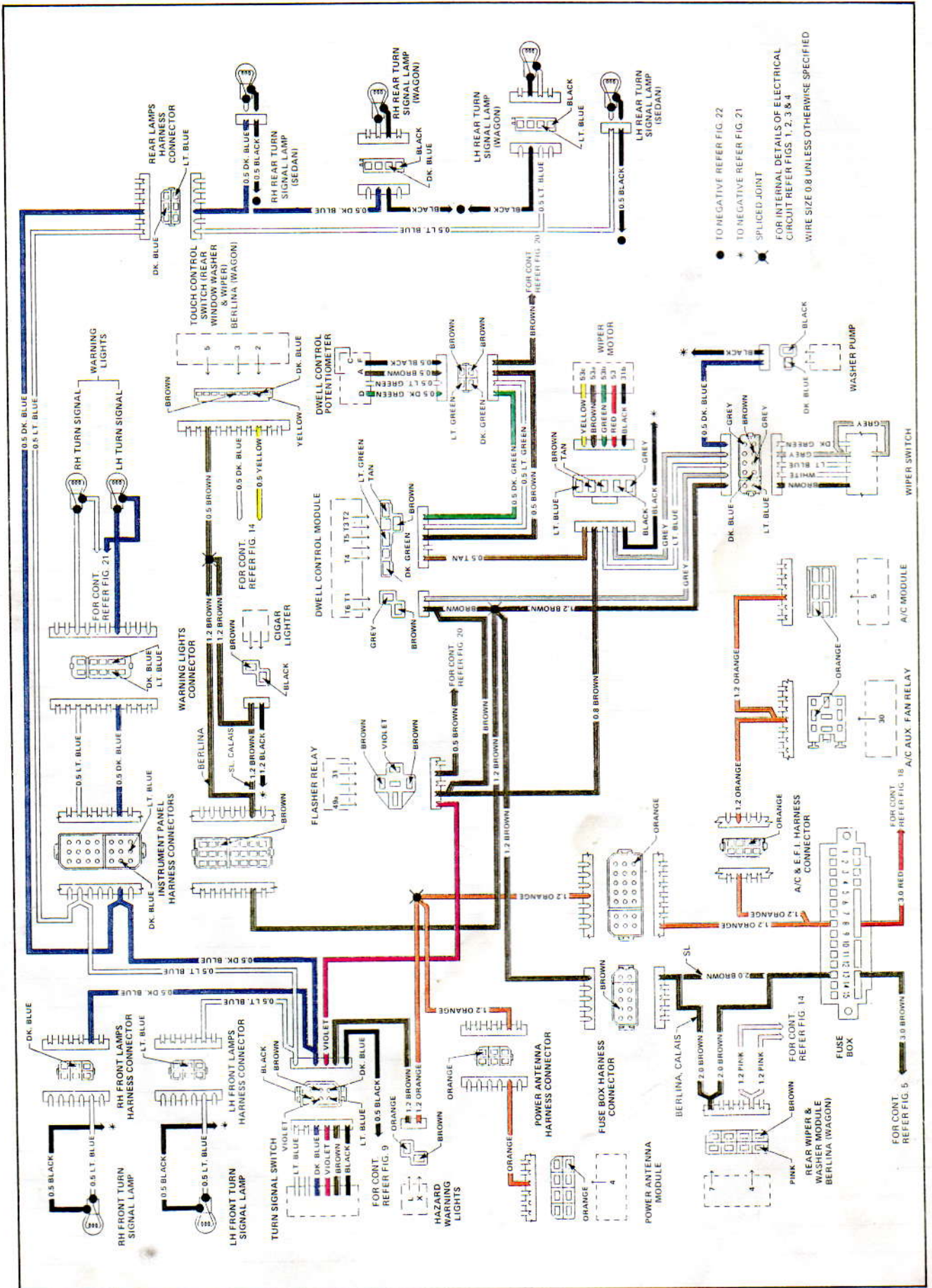

Figure 12F-13 Cigar Lighter, Turn Signal and Hazard Warning Lamps, Wiper Washer and Dwell Control

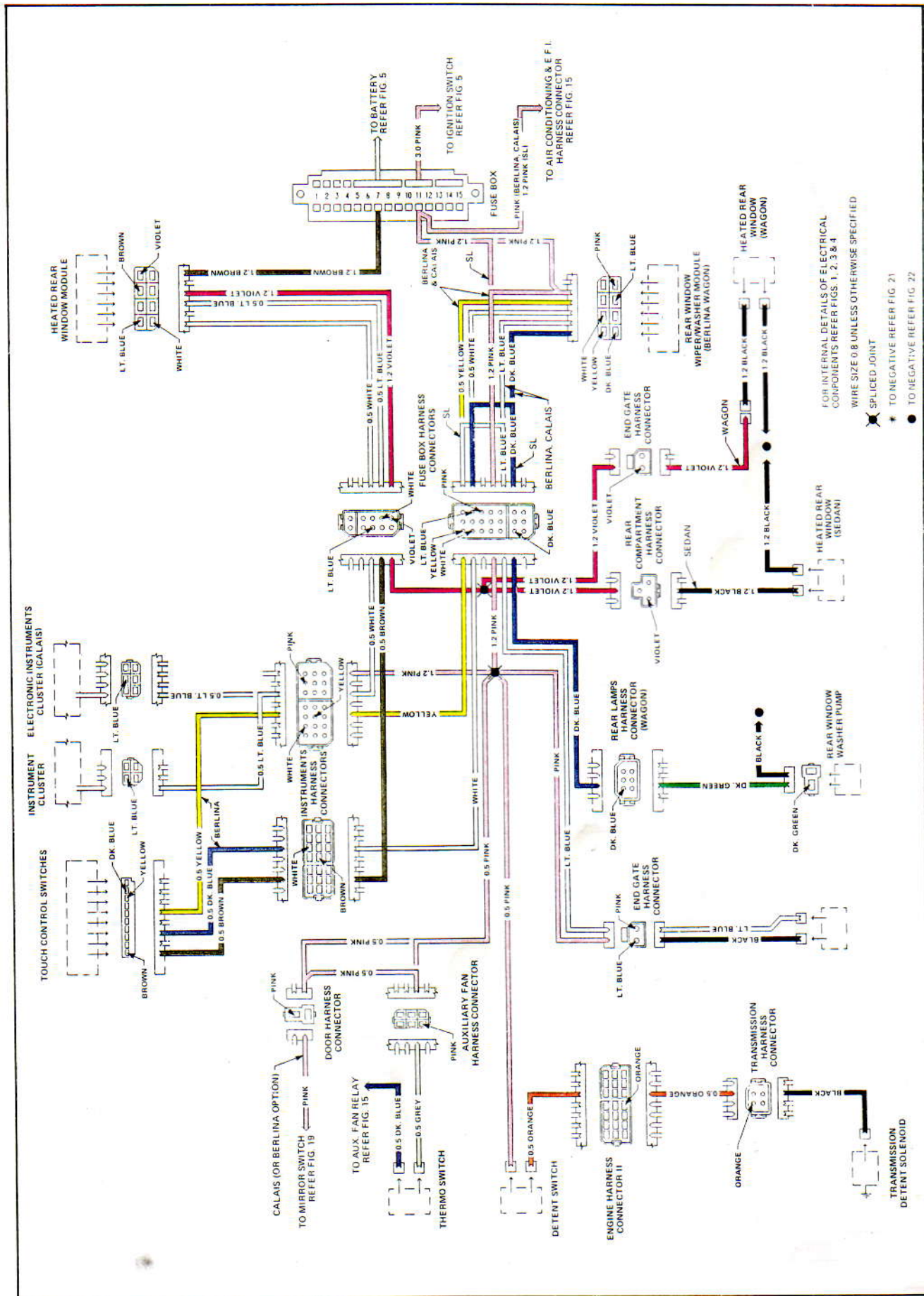

Figure 12F-14 Heated Rear Window and Rear Window Wiper and Washer

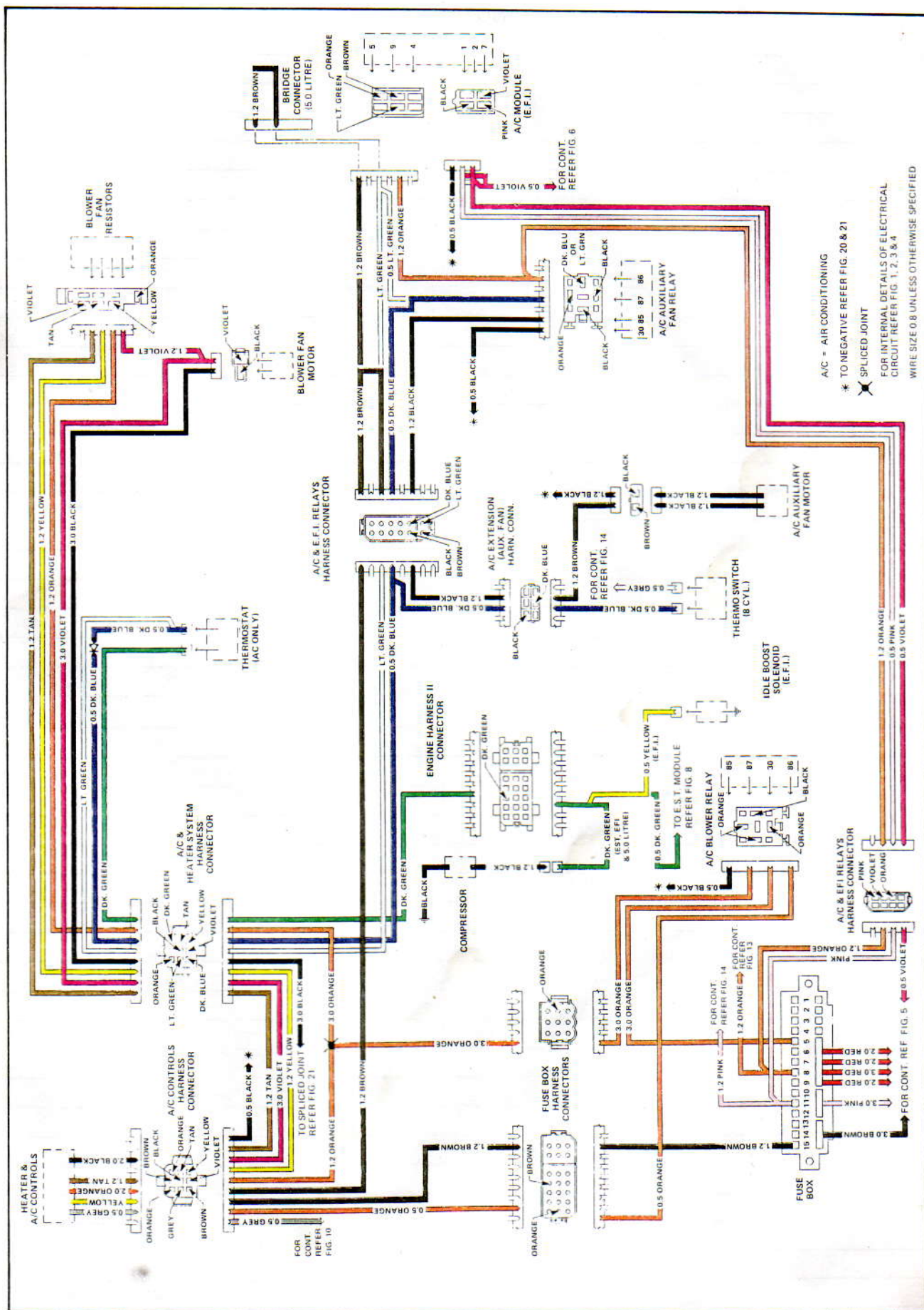

Figure 12F-15 Heating and Air Conditioning

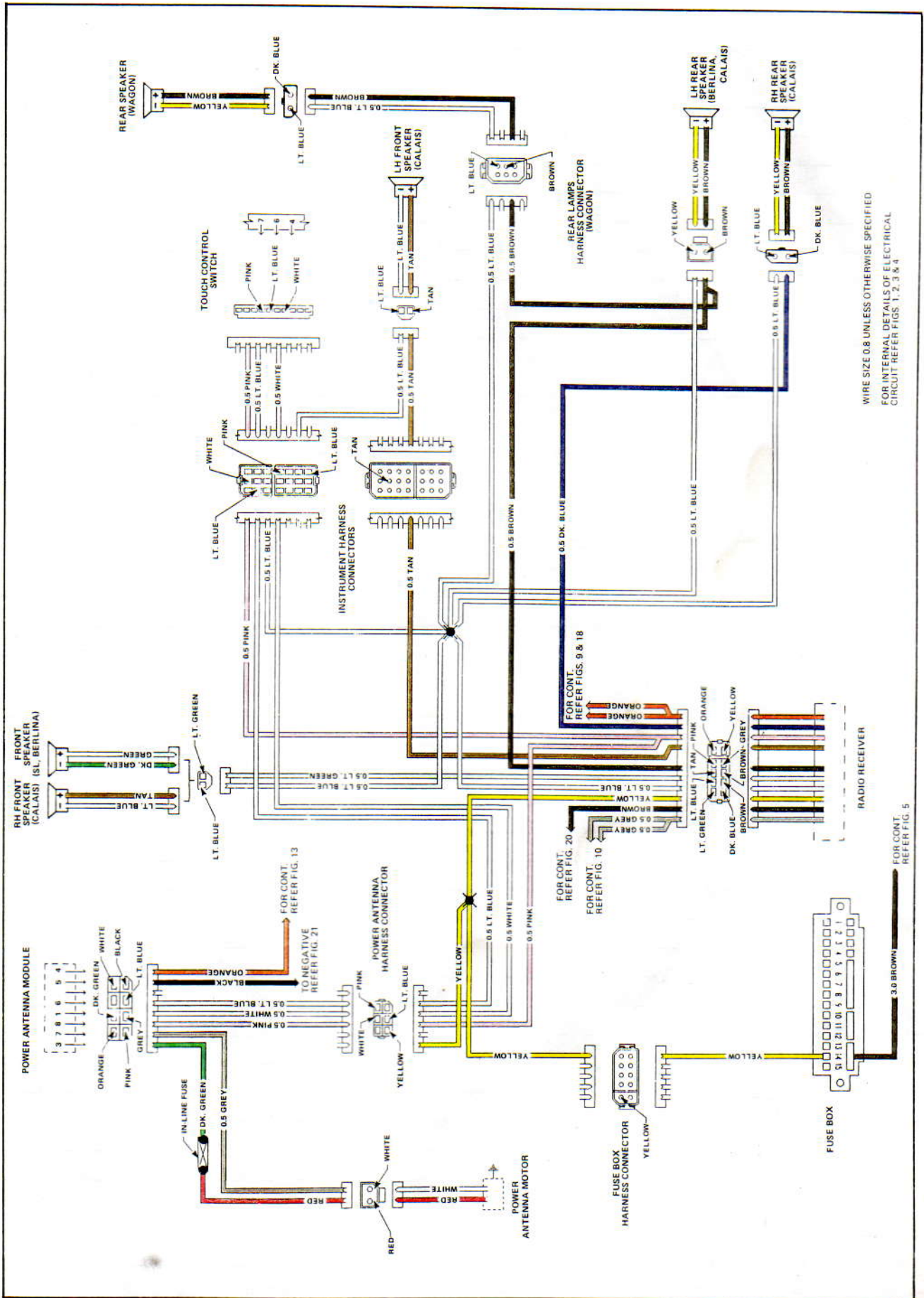

Figure 12F-16 Radio and Power Antenna

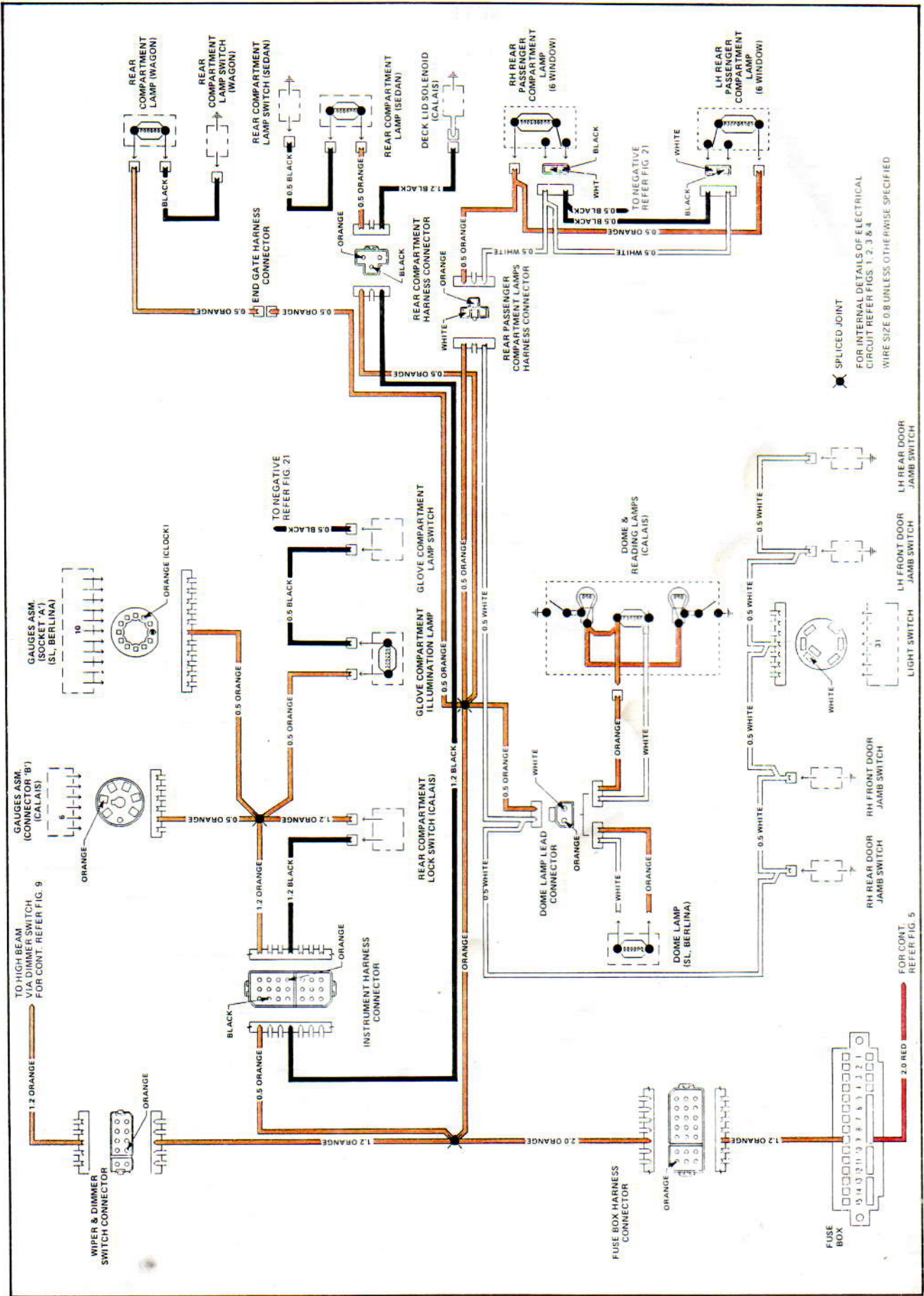

Figure 12F-17 Clock, Trip Computer, Interior Illumination, Rear compartment Lamp and Lock

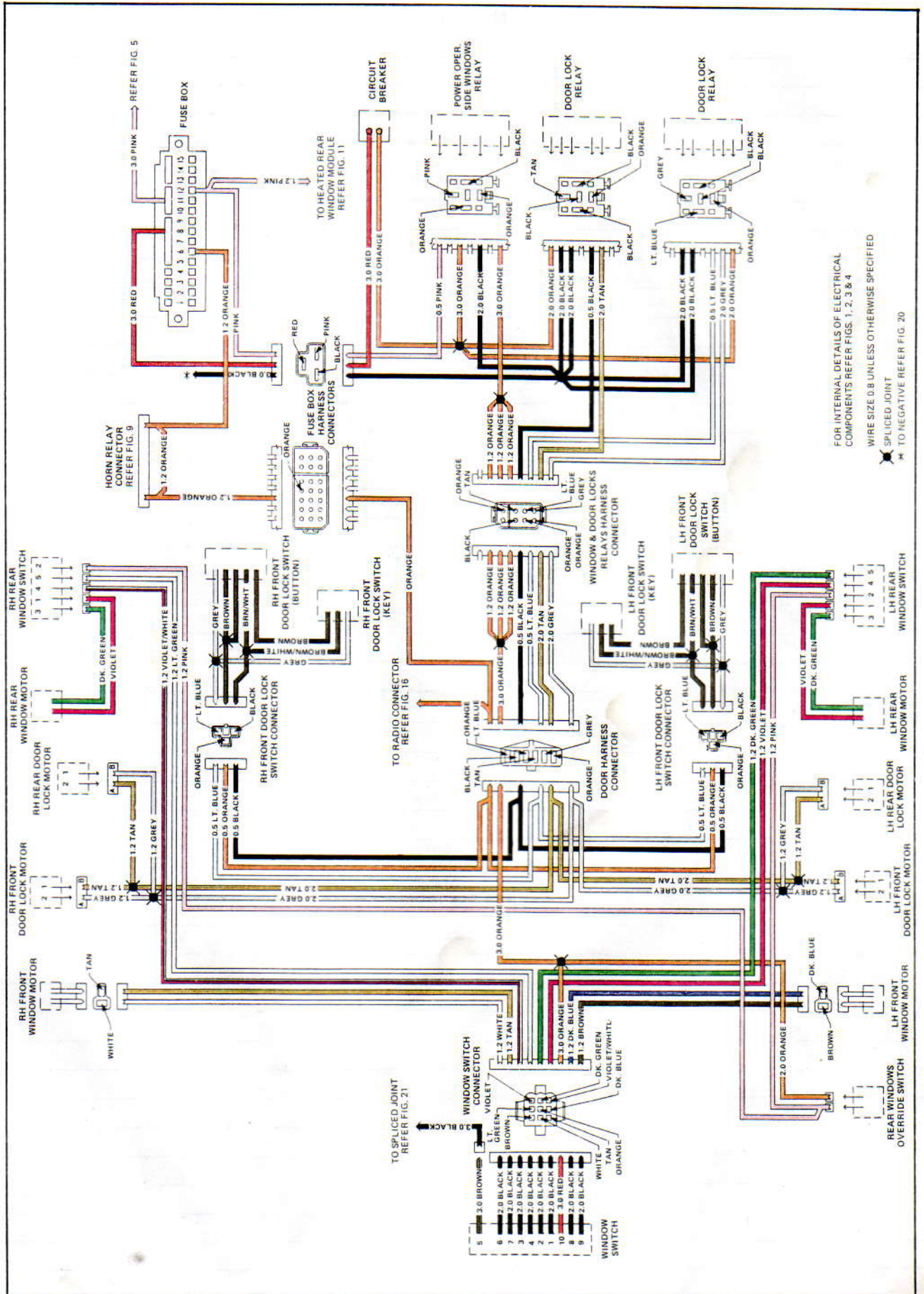

Figure 12F-18 Electric Door Locks and Power Operated Side Windows

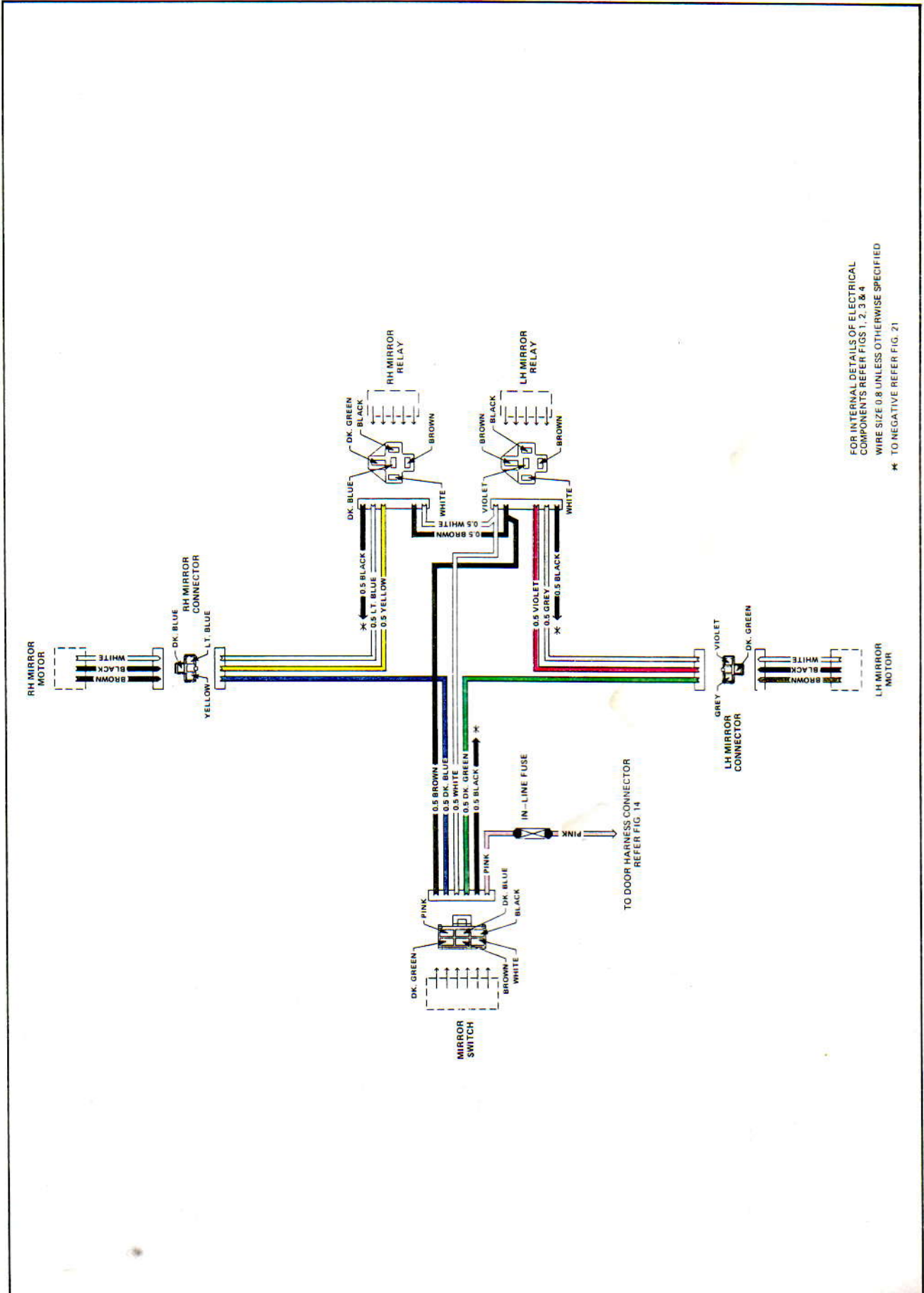
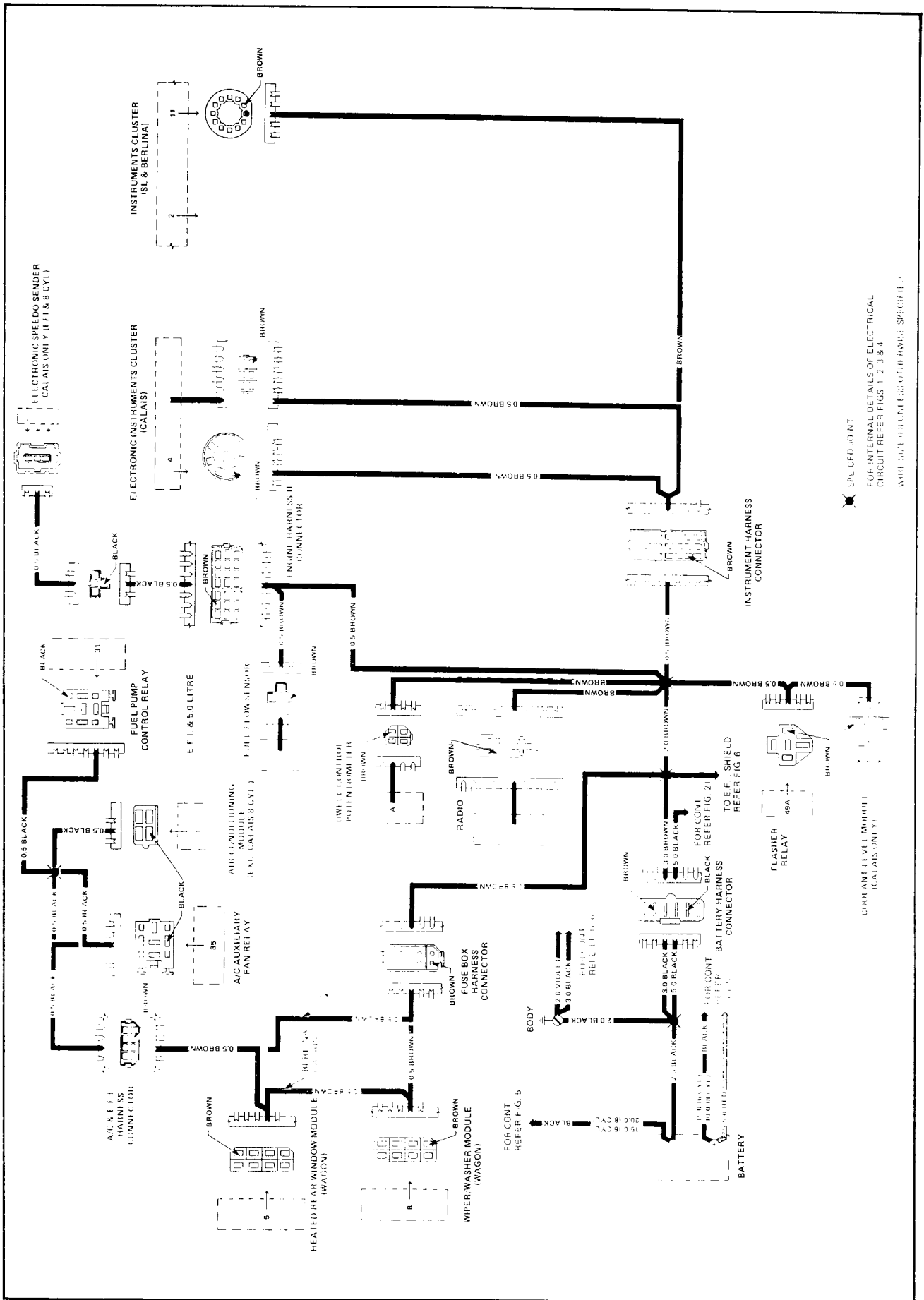

Figure 12F-19 Electric Mirrors



SPliced JOINT
 FOR INTERNAL DETAILS OF ELECTRICAL
 CIRCUIT REFER FIGS 1, 2, 3 & 4
 WAGON SPECIFIC ELECTRICAL HARNESS SPECIFIC 111

Figure 12F-20 Front Earthing Circuit

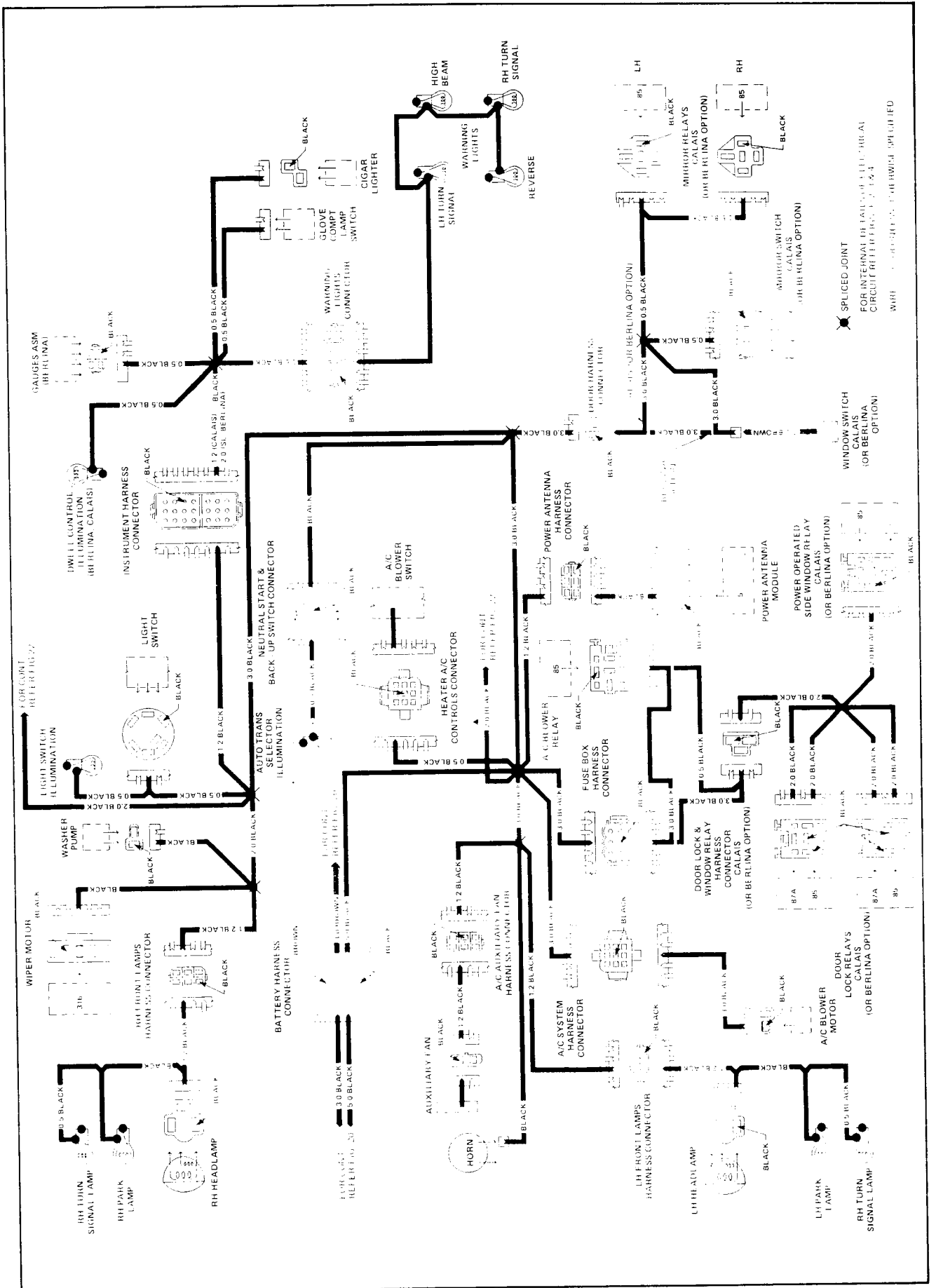
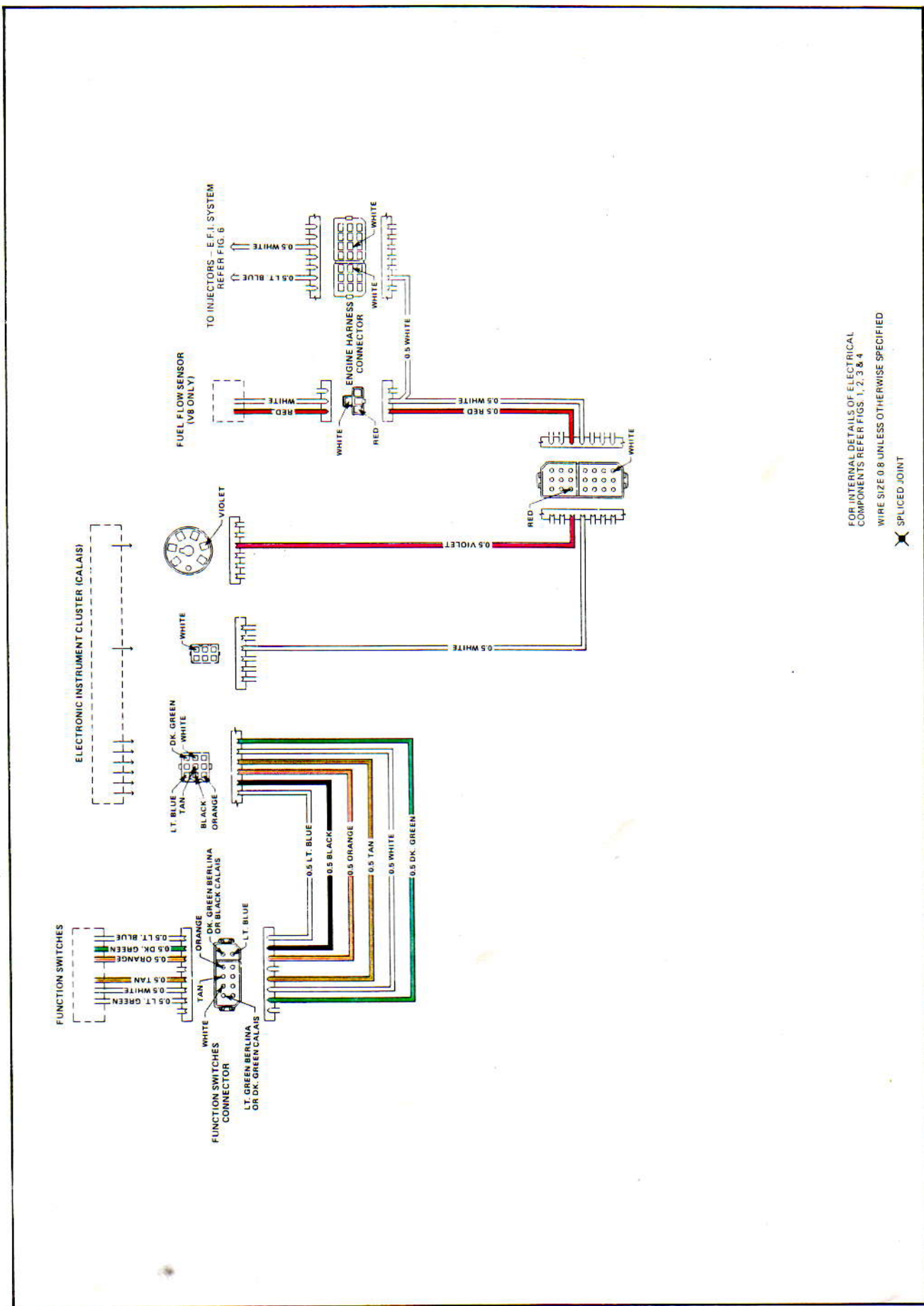

Figure 12F-21 Front Earthing Circuit Continued



FOR INTERNAL DETAILS OF ELECTRICAL COMPONENTS REFER FIGS 1, 2, 3 & 4
 WIRE SIZE 0.8 UNLESS OTHERWISE SPECIFIED
 X SPLICED JOINT

Figure 12F-23 Trip Computer